

250 x 100 x 50 cm

98.4" x 39.4" x 19.7"

KIT SIMONCLICK PLUS 6/500

5 Años Garantía
Years Guarantee
Jahre Garantie
Ans Garantie
Anos de Garantía

SIMONRACK



1080 kg
(2381 lb)
Total

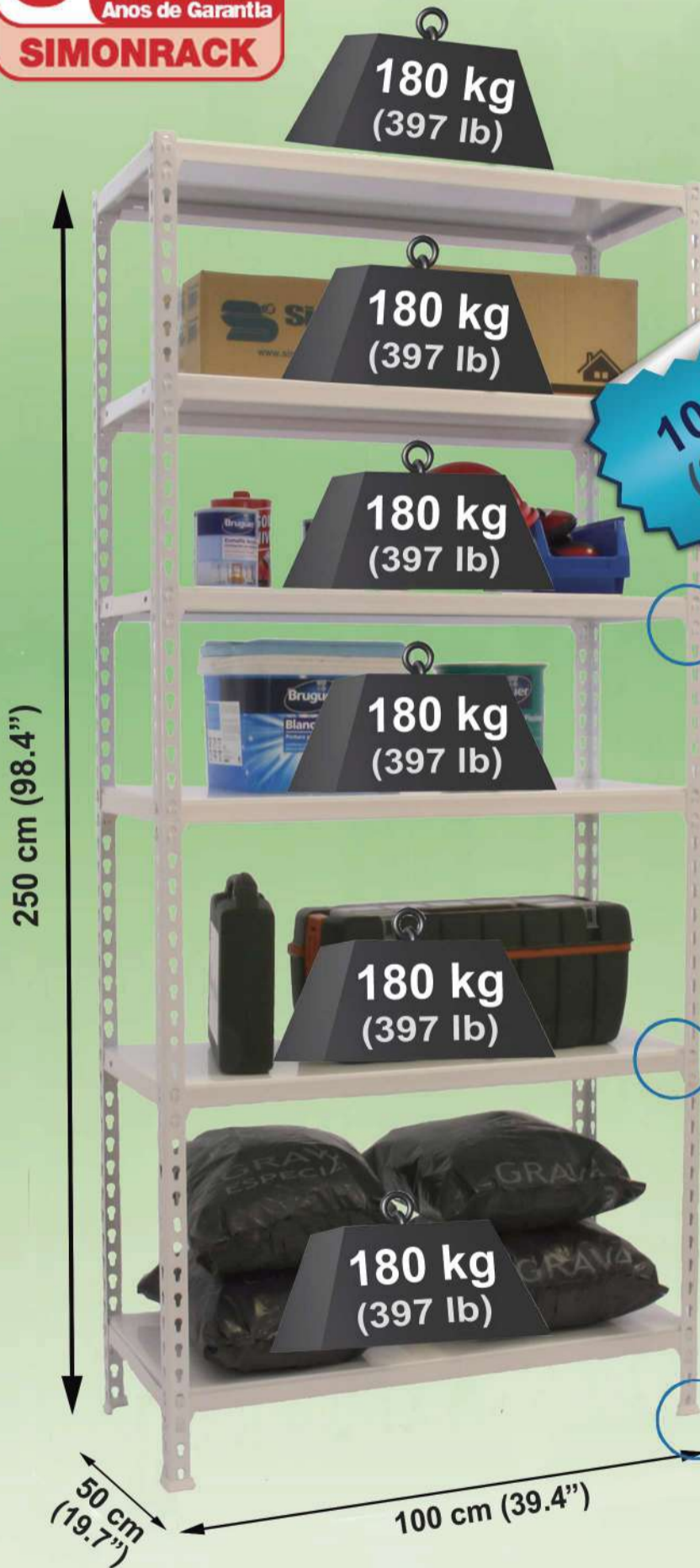

ESTANTERIAS SIMON S.L. B.50.556.463
PG. ALFAMEN C/ POLIGONO C, N°3
ALFAMEN (ZARAGOZA)



www.simonrack.com



INSTRUCTIONS

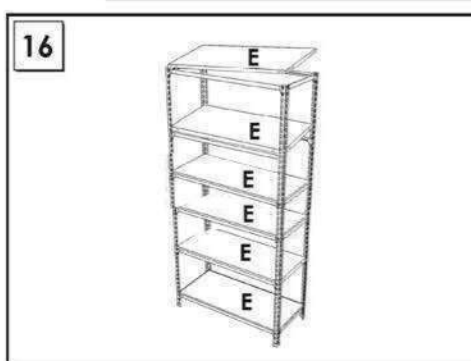
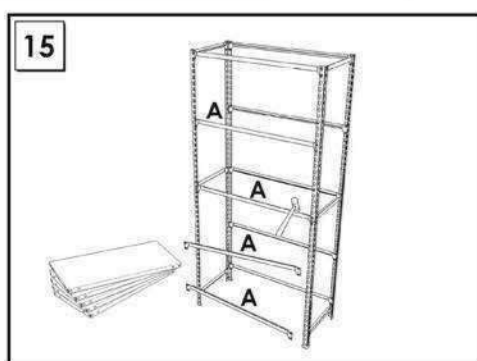
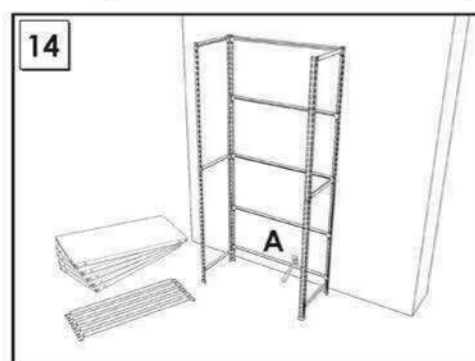
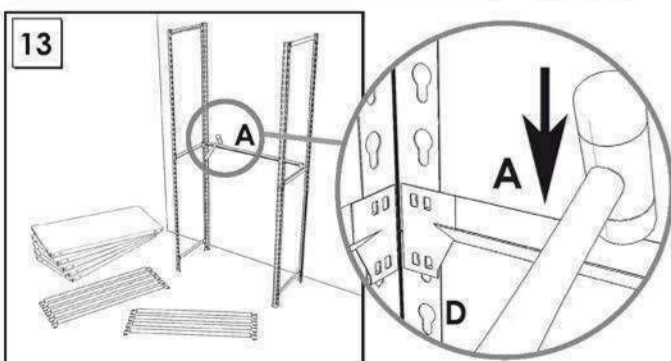
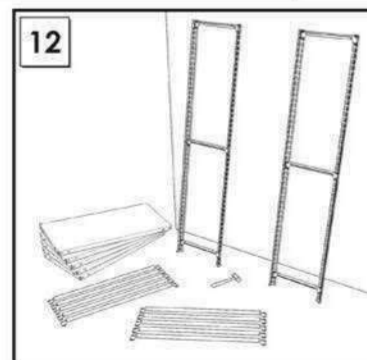
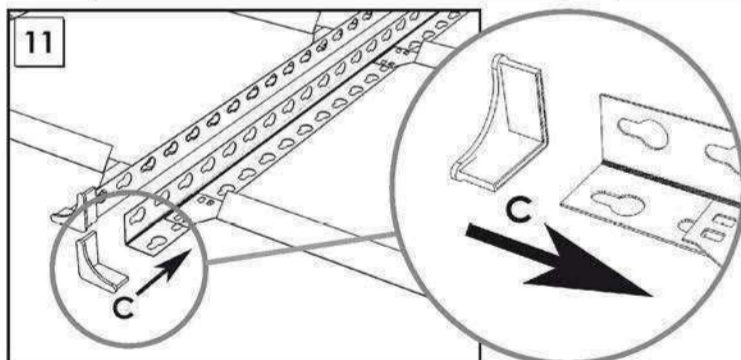
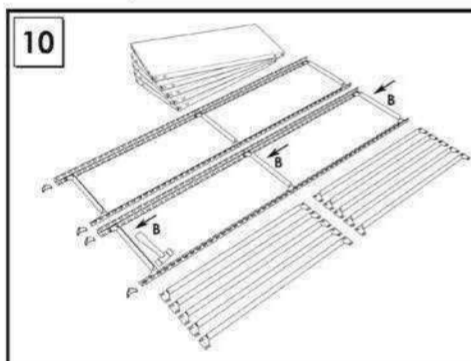
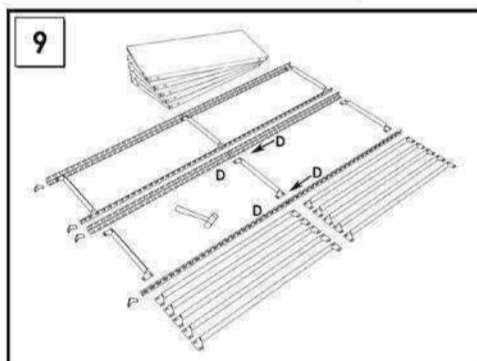
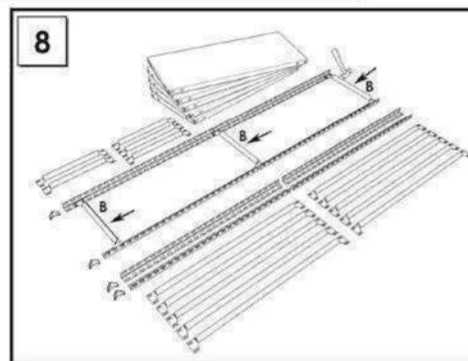
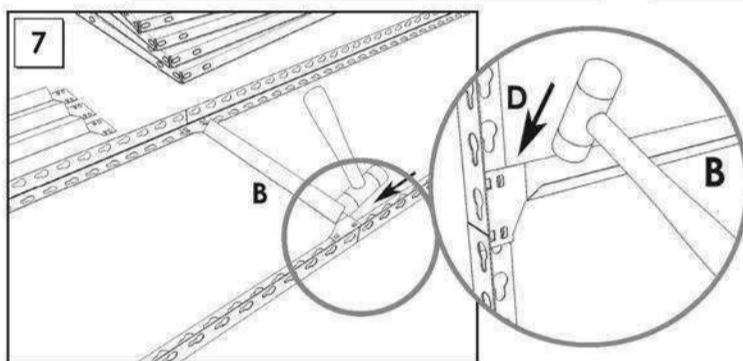
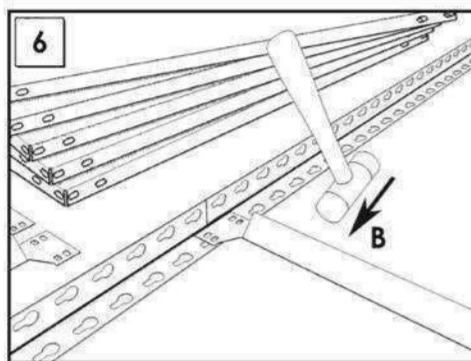
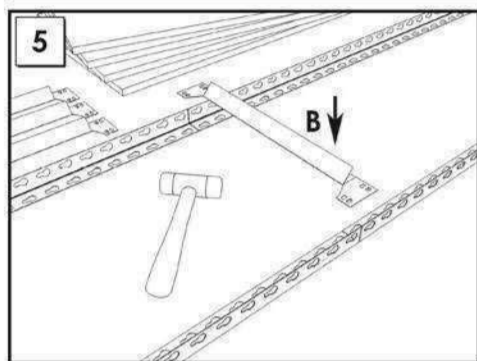
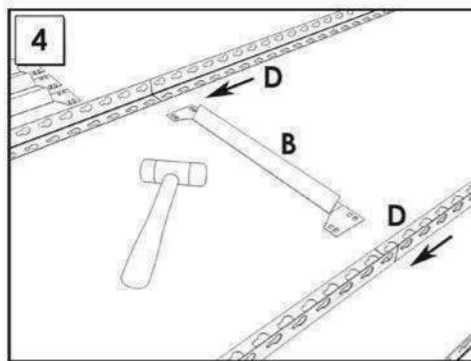
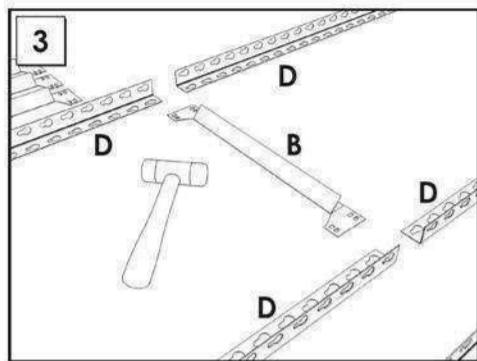
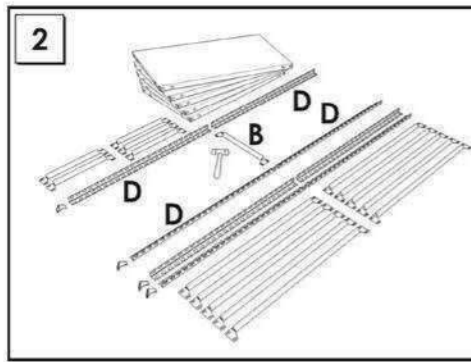
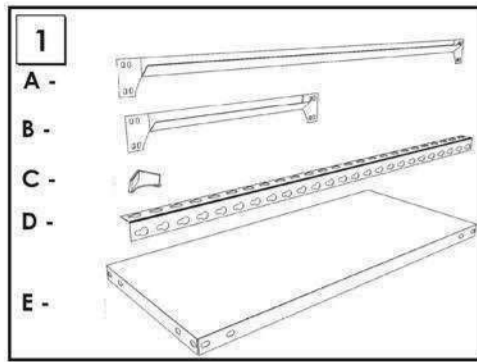

On-line instructions: www.instructionsrack.com/simonclick

SIMONCLASSIC

BOLTS SYSTEM

Up to 150 Kg
(331 lb)
Kg/Shelf
(Maximum Distributed Load)



SIMONCLICK

NO BOLTS SYSTEM

Up to 400 Kg
(882 lb)
Kg/Shelf
(Maximum Distributed Load)



SIMONOFFICE

NO BOLTS SYSTEM

Up to 275 Kg
(606 lb)
Kg/Shelf
(Maximum Distributed Load)



SIMONTALLER

NO BOLTS SYSTEM

Up to 700 Kg
(1543 lb)
Kg/Shelf
(Maximum Distributed Load)



BANCOS DE TRABAJO WORK BENCHES

Up to 800 Kg
(1764 lb)
Kg/Shelf
(Maximum Distributed Load)



SIMONHOME

Up to 150 Kg
(331 lb)
Kg/Shelf
(Maximum Distributed Load)



TAQUILLAS LOCKER



SIMONTITÁN

NO BOLTS SYSTEM

Up to 900 Kg
(1984 lb)
Kg/Shelf
(Maximum Distributed Load)



SIMONINOX

NO BOLTS SYSTEM



SIMONPALET

Up to 4500 Kg
(9921 lb)
Kg/Shelf
(Maximum Distributed Load)



SIMONLEVER



ALTILLOS Y PASILLOS ELEVADOS PLATFORMS AND MEZZANINES

