

180 x 90 x 40 cm^{*}

70.9" x 35.4" x 15.8"

SIMONCLICK 5/400

5 Años Garantía
Years Guarantee
Jahre Garantie
Ans Garantie
Anos de Garantia
SIMONRACK



*MEDIDAS EN USO: 1781 x 911 x 410 mm
USED MEASUREMENTS: 70.12" x 35.87" x 16.14"



ESTANTERIAS SIMON S.L. B. 60.556.463
PG. ALFAMEN C/ POLIGONO C, Nº3
ALFAMEN (ZARAGOZA)



www.simonrack.com

Simon Rack
SINCE 1964 - MANUFACTURER



INSTRUCTIONS

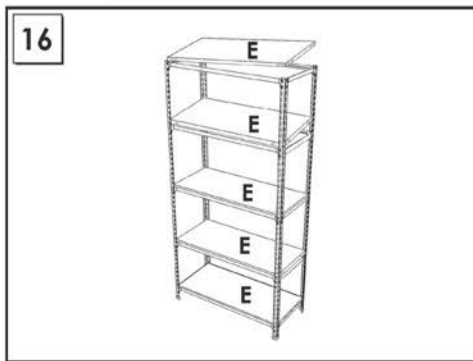
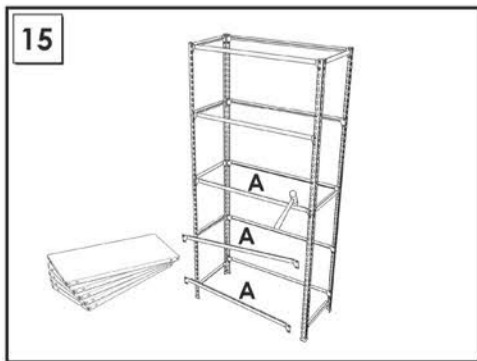
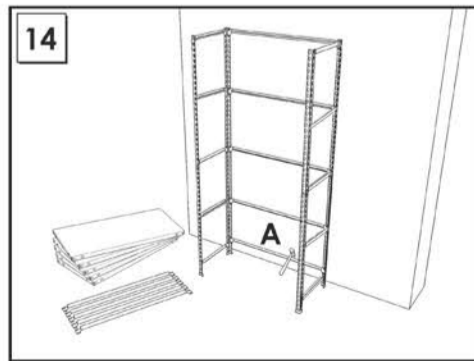
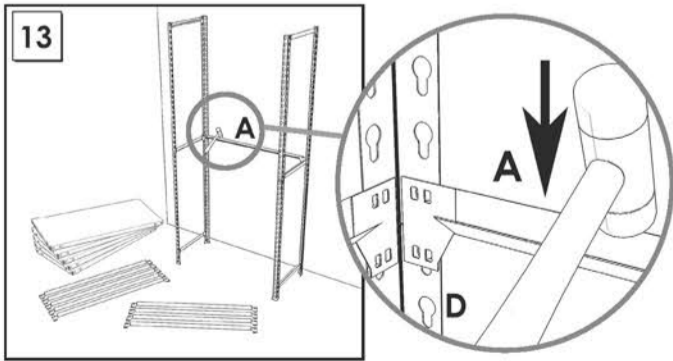
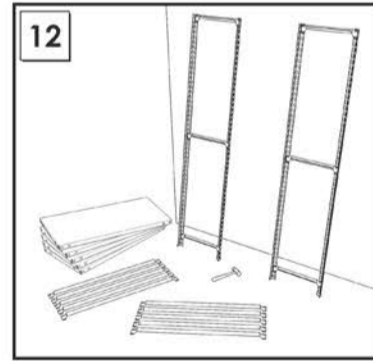
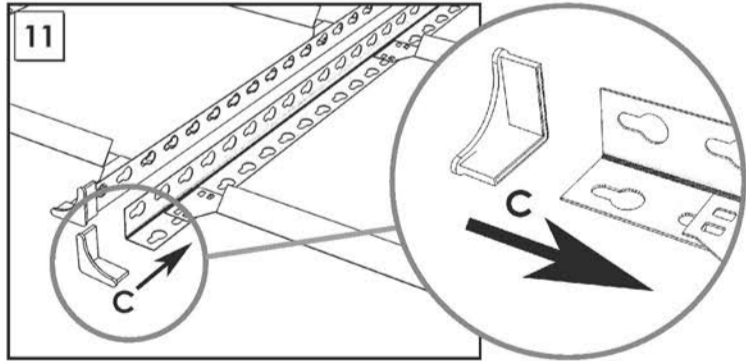
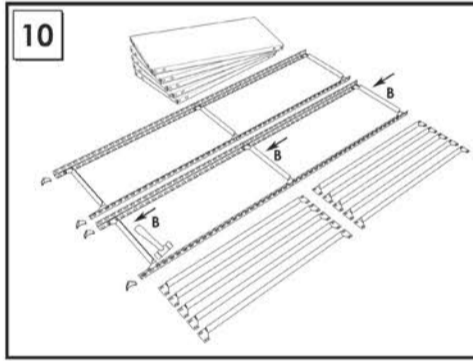
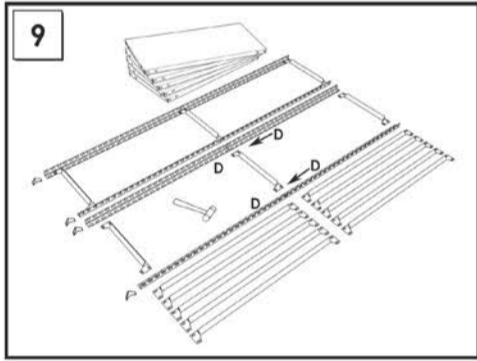
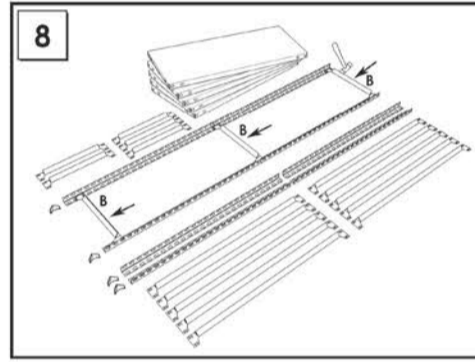
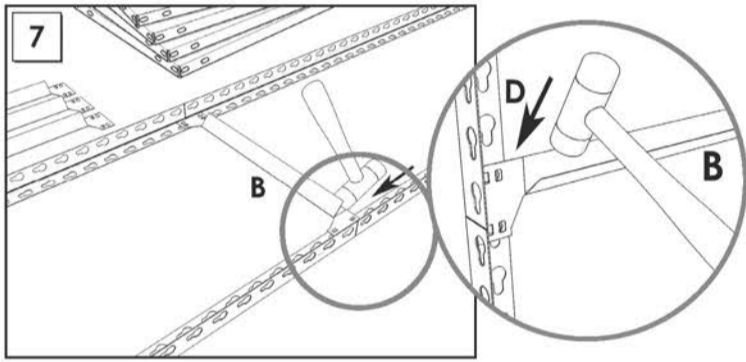
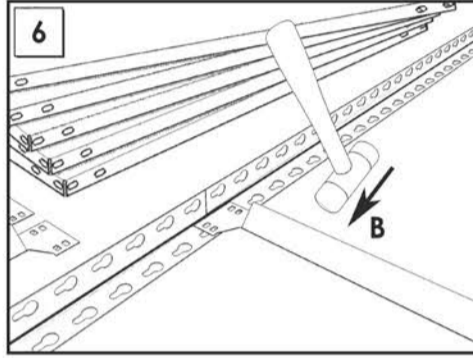
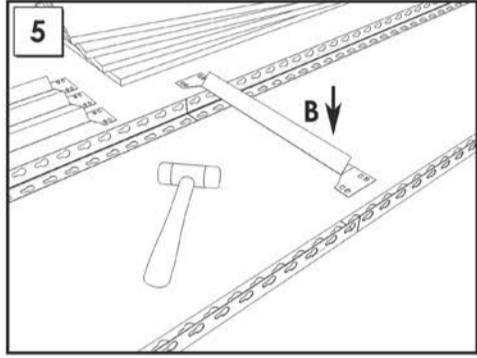
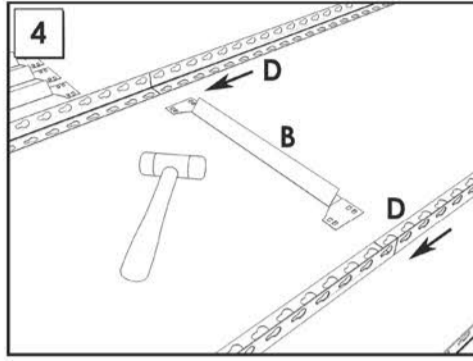
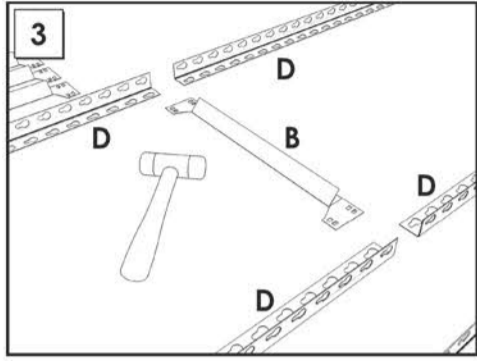
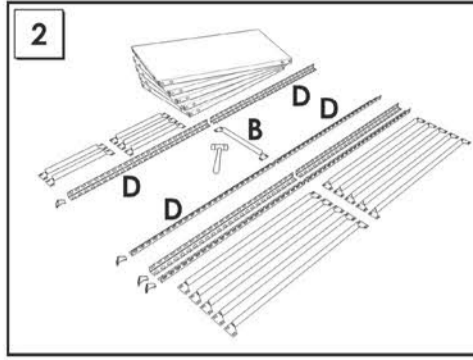
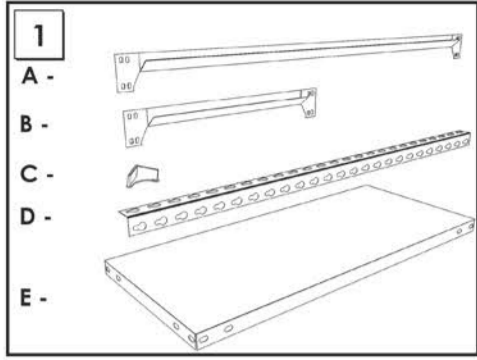

On-line instructions: www.instructionsrack.com/simonclick

SIMONCLASSIC



Up to:
150 Kg
(331 lb)
Kg/Shelf
Uniformly Distributed Load



SIMONCLICK



Up to:
400 Kg
(882 lb)
Kg/Shelf
Uniformly Distributed Load



SIMONOFFICE



Up to:
275 Kg
(606 lb)
Kg/Shelf
Uniformly Distributed Load



SIMONTALLER



Up to:
700 Kg
(1543 lb)
Kg/Shelf
Uniformly Distributed Load



**BANCOS DE TRABAJO
WORK BENCHES**

Up to:
800 Kg
(1764 lb)
Kg/Shelf
Uniformly Distributed Load



SIMONHOME

Up to:
150 Kg
(331 lb)
Kg/Shelf
Uniformly Distributed Load



**TAQUILLAS
LOCKER**



SIMONTITÁN

NO BOLTS SYSTEM

Up to:
900 Kg
(1984 lb)
Kg/Shelf
Uniformly Distributed Load



SIMONINOX

NO BOLTS SYSTEM



SIMONPALET

Up to:
4500 Kg
(9921 lb)
Kg/Shelf
Uniformly Distributed Load



SIMONLEVER



**ALTILLOS Y PASILLOS ELEVADOS
PLATFORMS AND MEZZANINES**

