

ELEGANCE OPEN TOWEL RING 200mm. / T.ANILLA ABIERTA 200mm.

creabath®

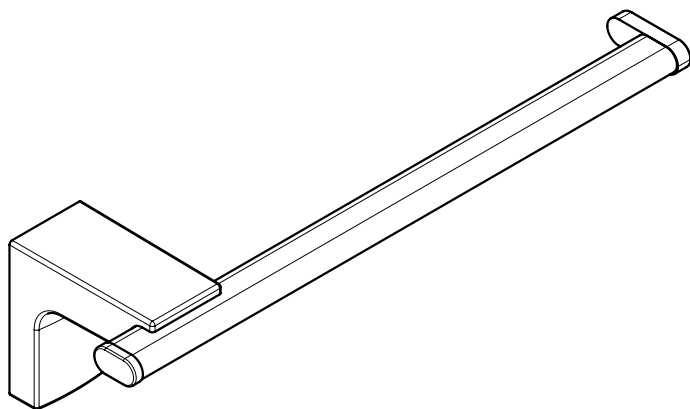

FIJACION PARED
WALL FIXATION

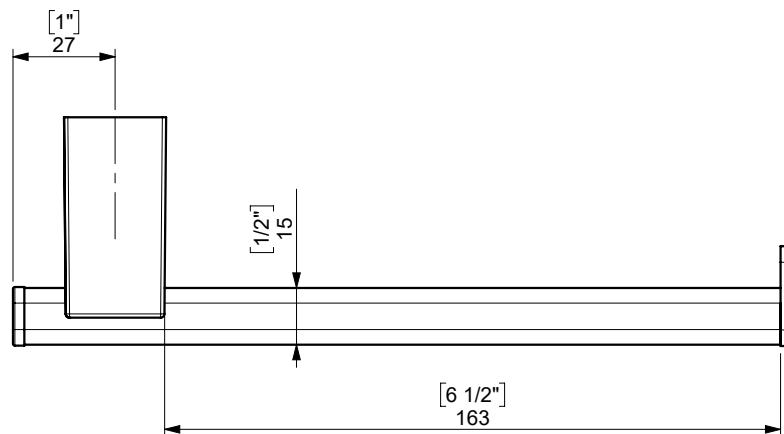
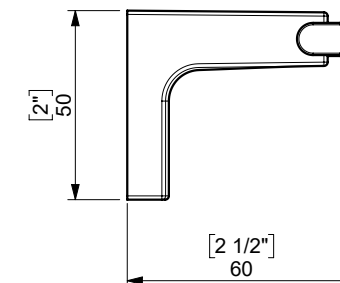
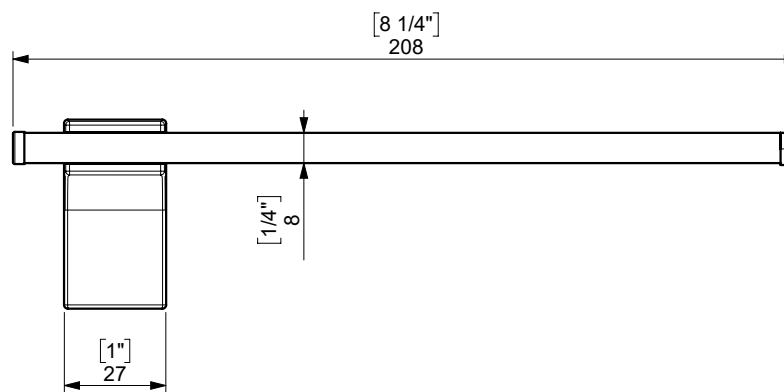
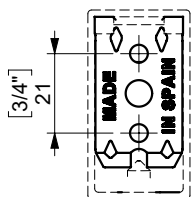

espec_499

Peso / Weight / Poids : 0,300 Kg.

Data / Datos / Données:

Normas / Regulations / Normes: UNE 67100, UNE EN 3497, UNE EN ISO 1456, UNE EN ISO 9227, UNE EN ISO 4541, UNE EN ISO 2819, UNE-EN ISO 4541

Imágenes no a escala / Draw not to scale / Echelle non respectée



www.creabath.com