

KIEHNHOLZ

Systemlösungen
aus Holz

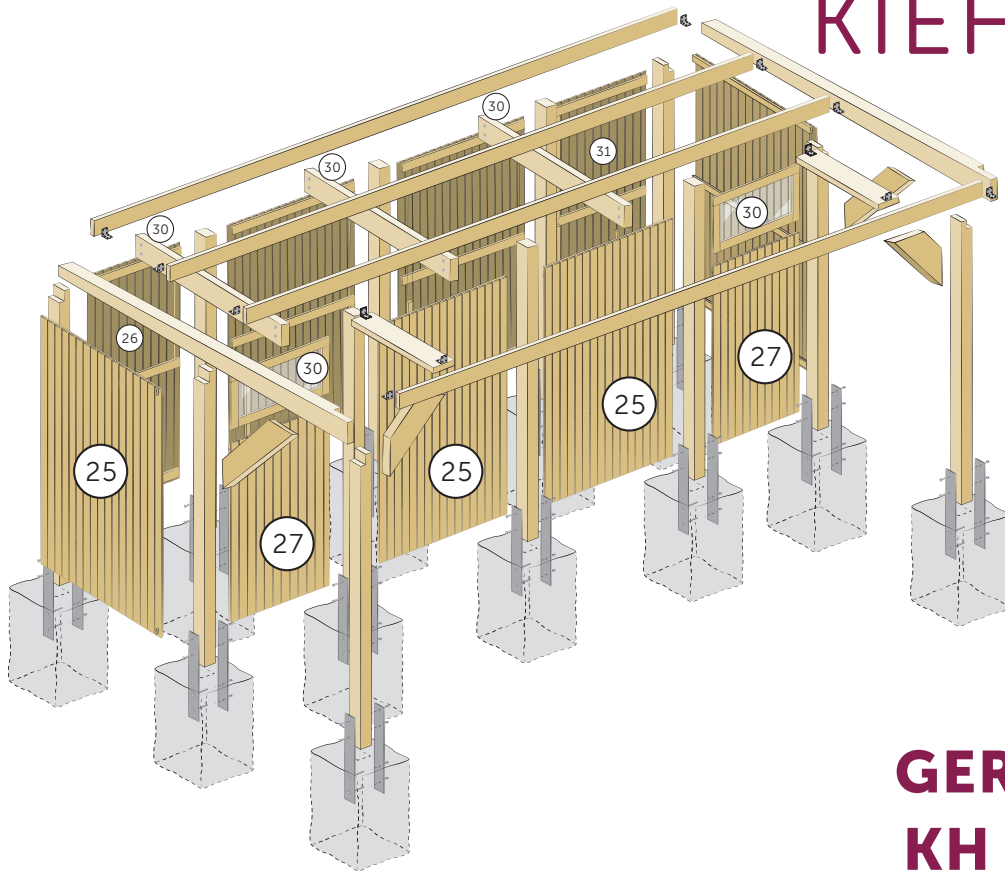

GERÄTEKAMMER KH 103 / KH 105 5,51 x 1,73 m



MONTAGEANLEITUNG

Instructions de montage
Istruzioni per il montaggio
Instrucciones de montaje



B Bemaßung KH 103

Dimensionnement KH 103
 Dimensioni KH 103
 Dimensionamento KH 103

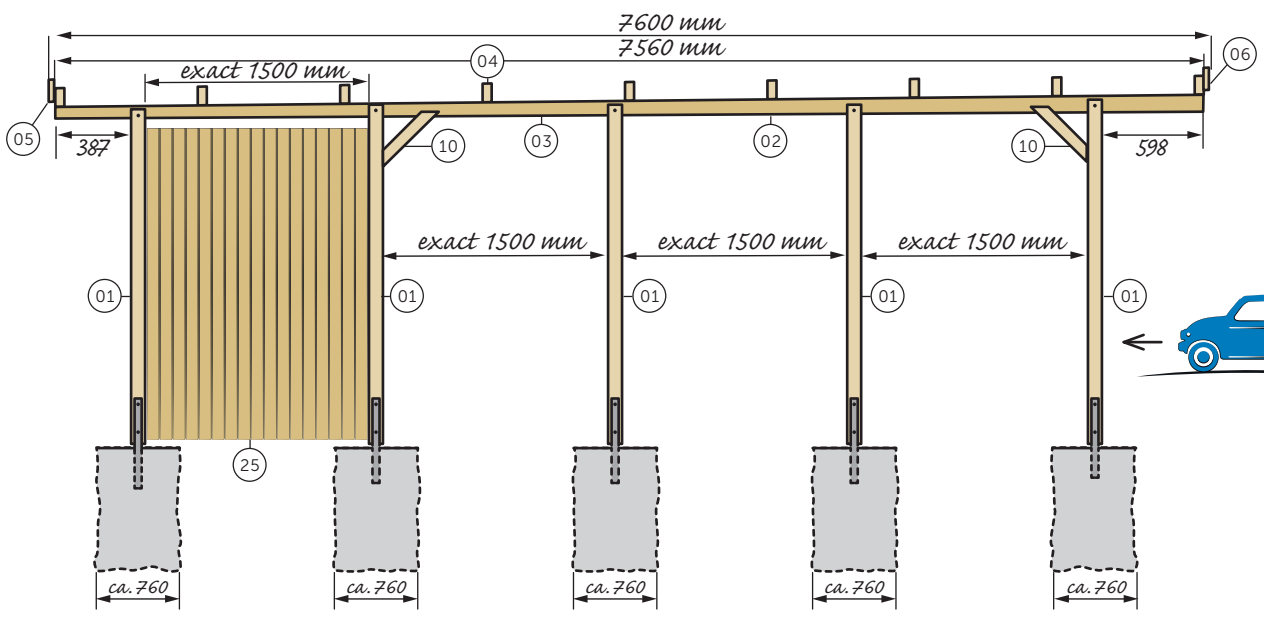
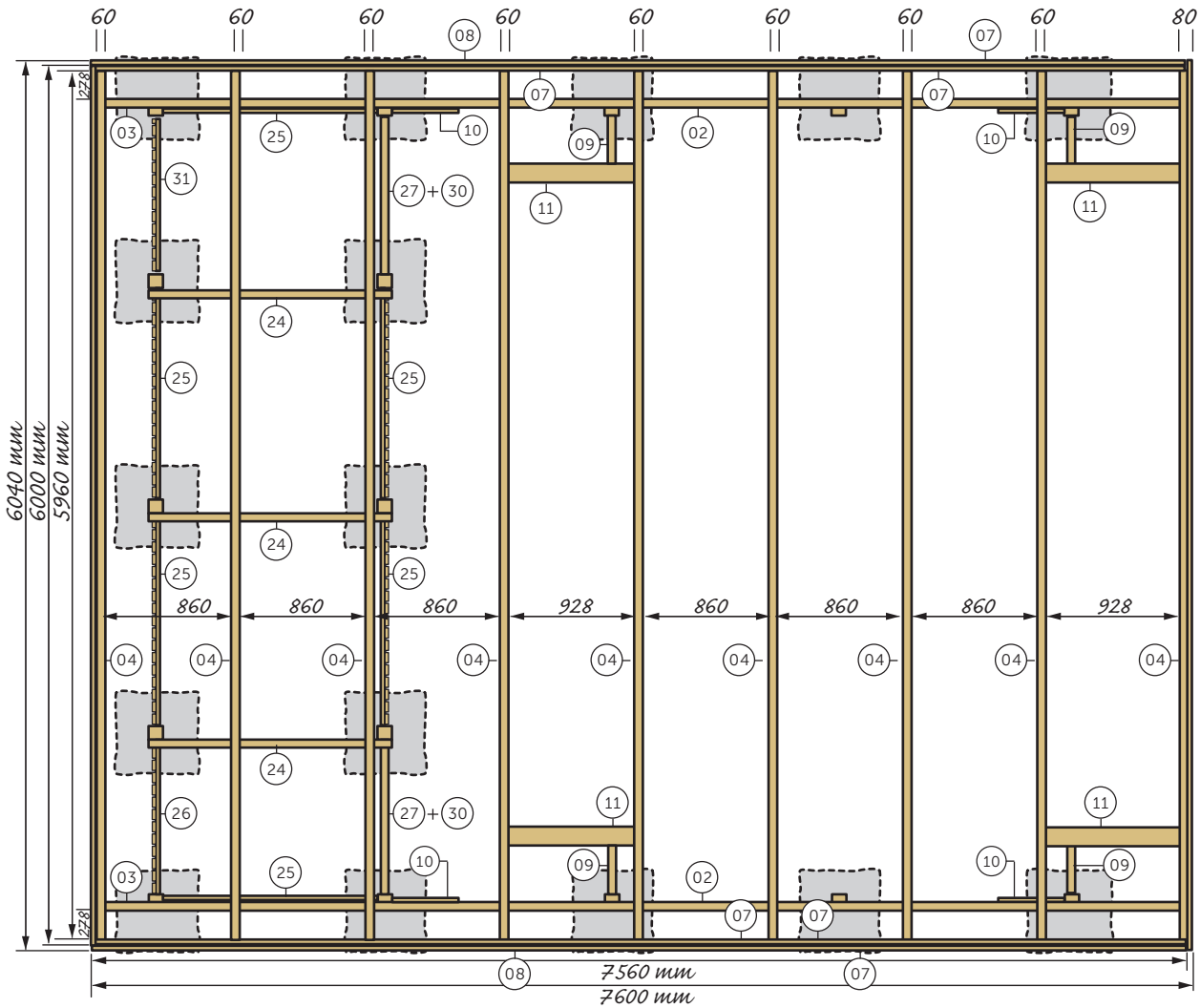

B Bemaßung KH 105

Dimensionnement KH 105
 Dimensioni KH 105
 Dimensionamiento KH 105

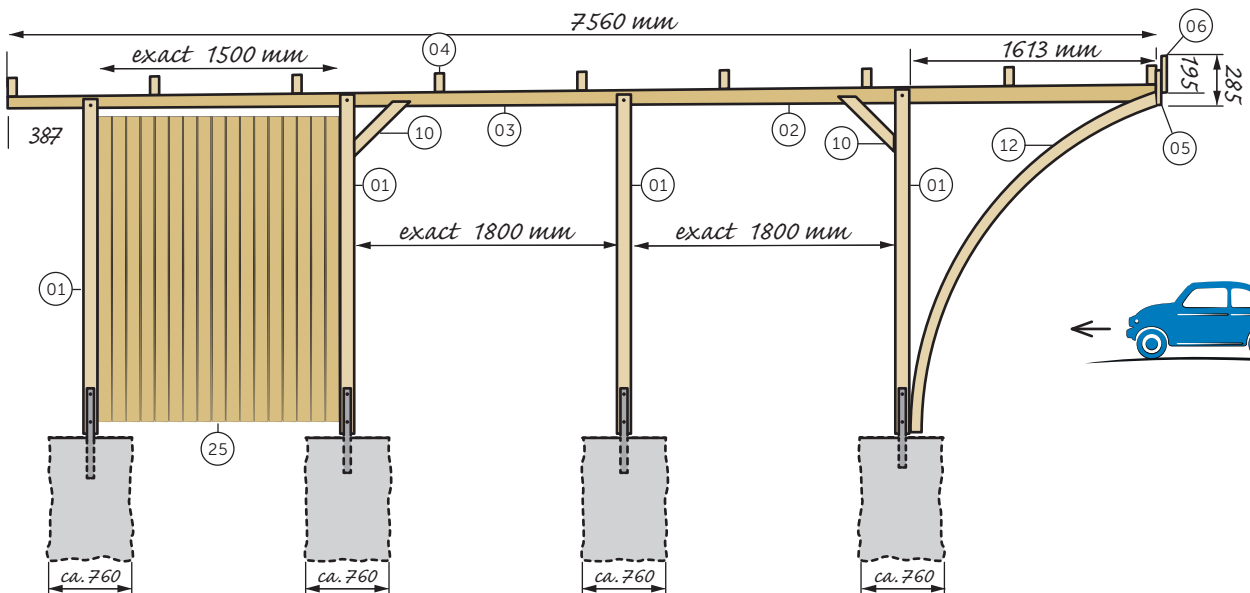
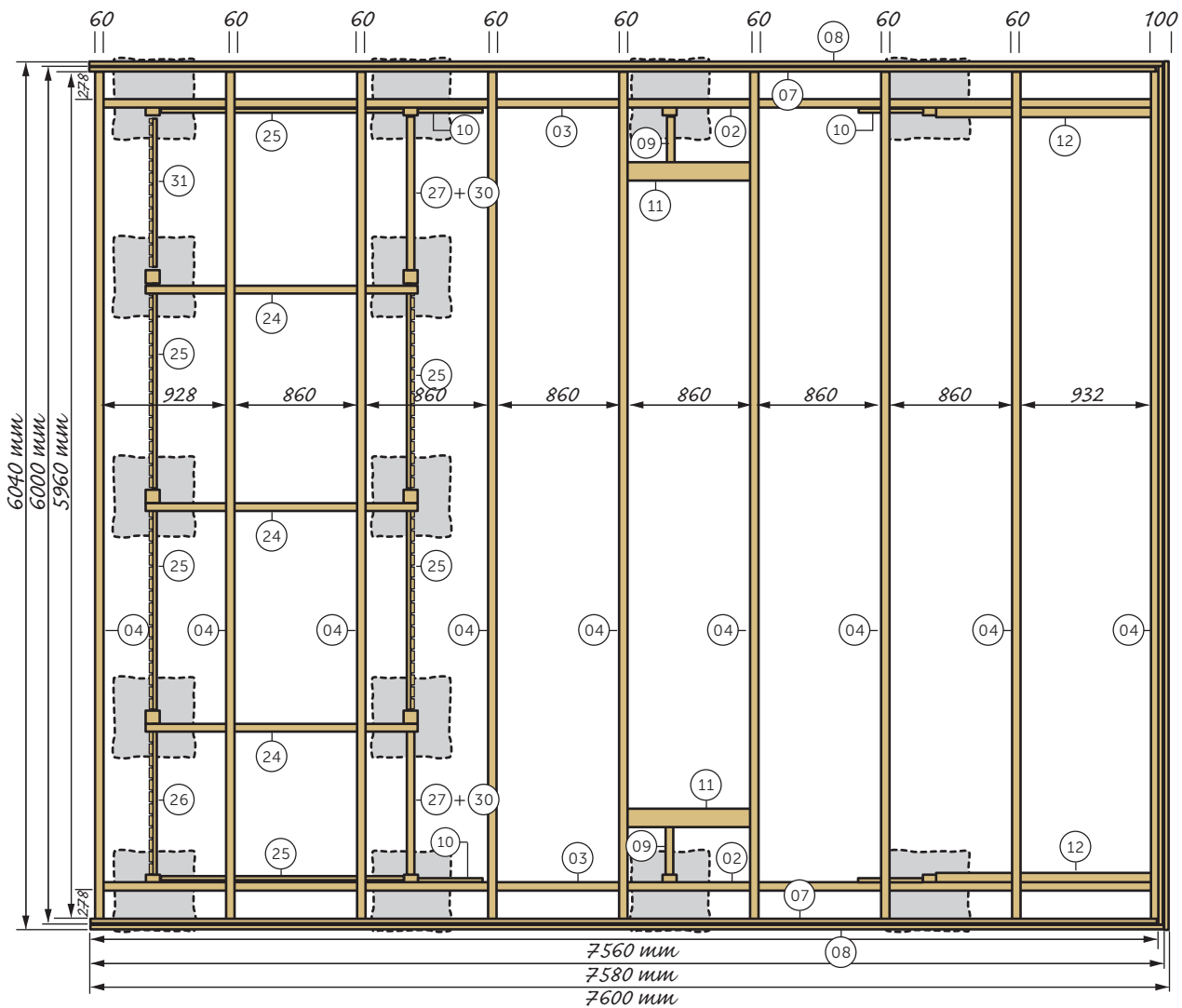

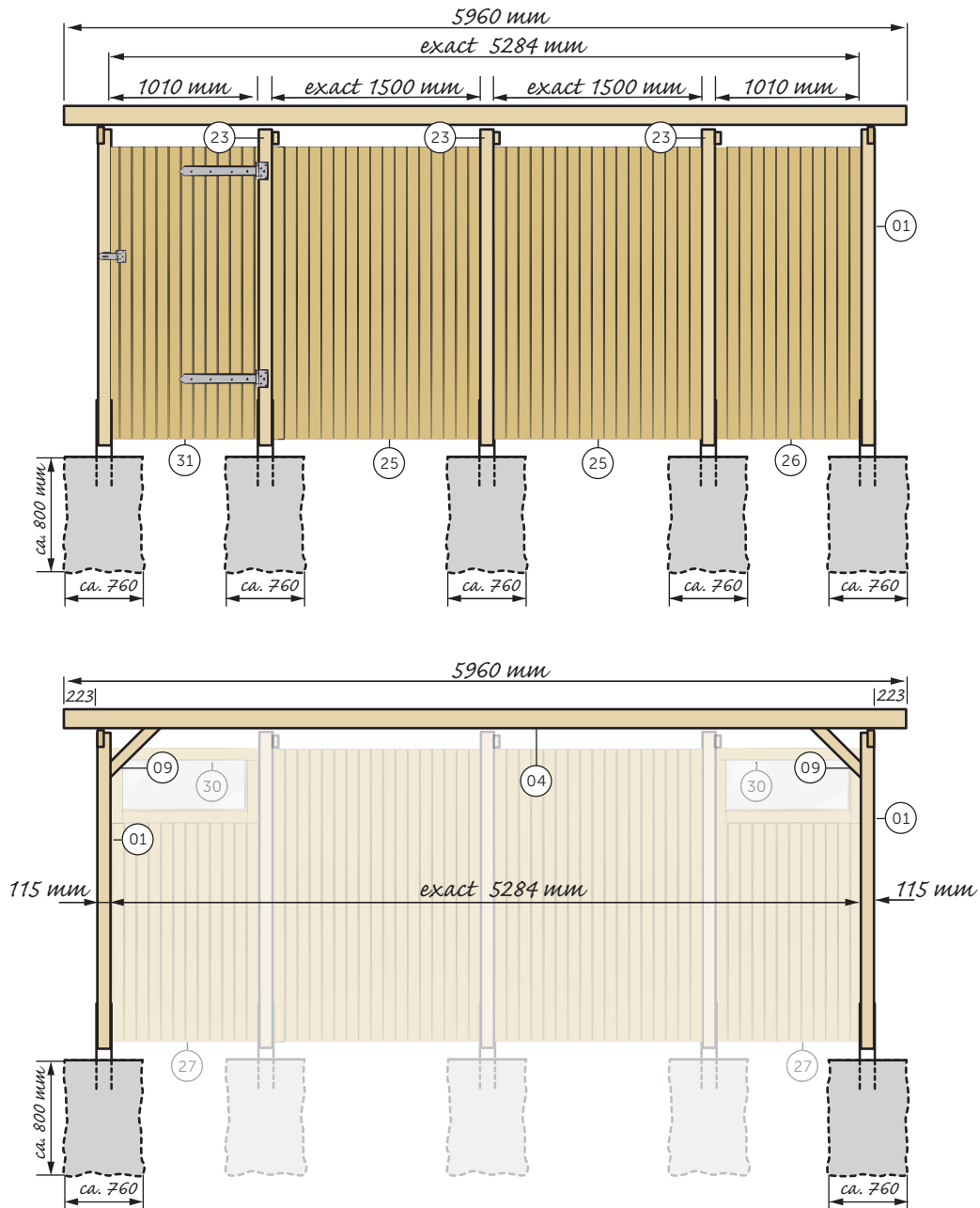

exakt ausrichten!
Aligner exactement
Orientamento esatto
Alinear de forma exacta

exakte Maße!
Dimensions précises
Dimensioni esatte
Mediciones precisas

regelmässig nachziehen!
Serrer les vis régulièrement
Serrare regolarmente
Apriete de los tornillos regular

Sicherung beim Aufbau!
Sécurité lors du montage
Sicurezza durante l'assemblaggio
Seguridad durante el montaje



Arbeiten Sie sicher!
Travaillez en toute sécurité!
Lavorare in sicurezza!
Trabaje de forma segura!

Sicherung beim Aufbau!
Sécurité lors du montage
Sicurezza durante l'assemblaggio
Seguridad durante el montaje

Alle Schraubverbindungen vorbohren!
Pré-percer tous les assemblages vissés.
Preforare tutti i collegamenti a vite.
Realizar perforaciones previas de todas las uniones roscadas.

1. Montage

Montage
Montaggio
Montaje

23		6 x
24		3 x
34		12 x

5 x 90 mm

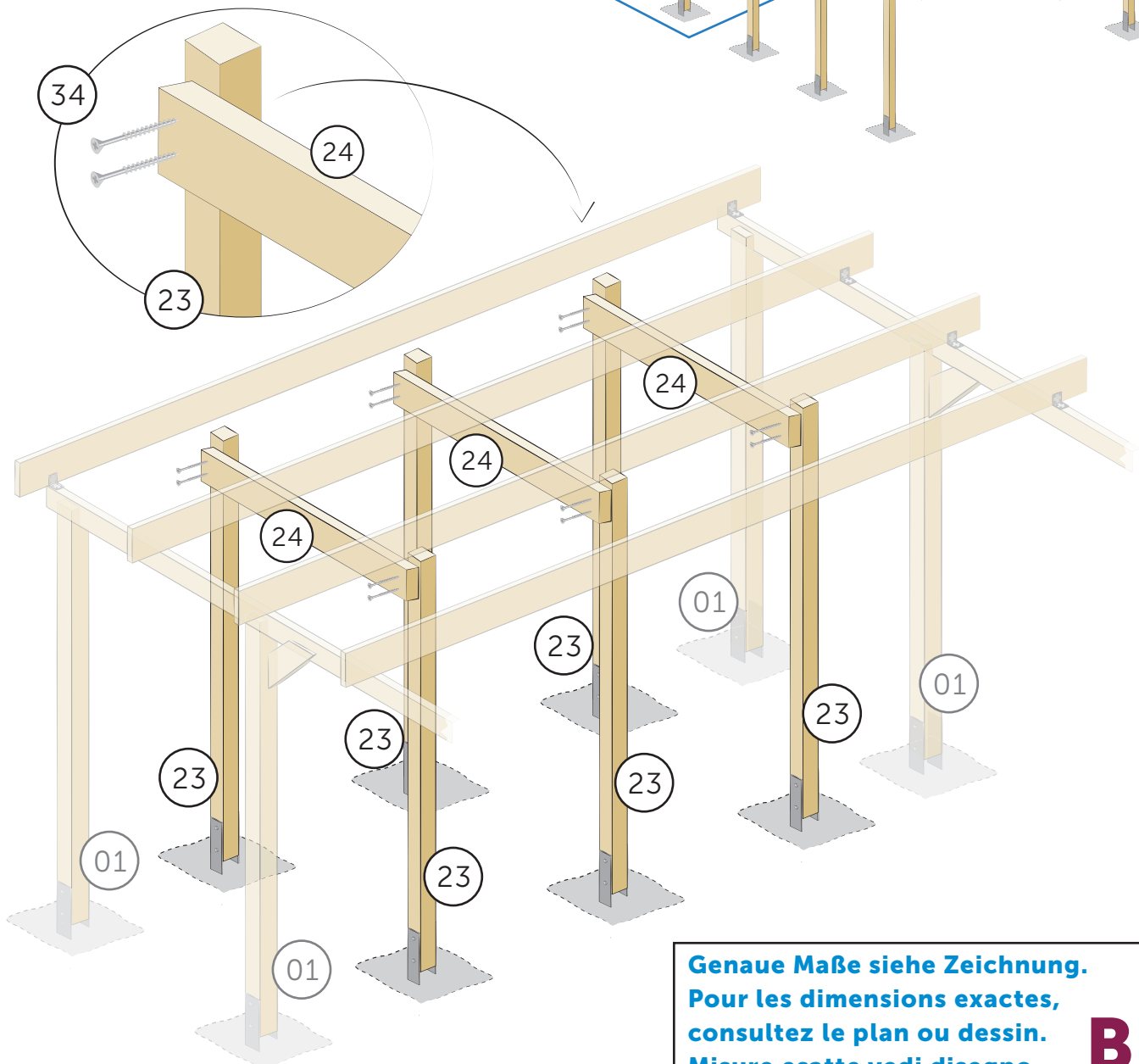
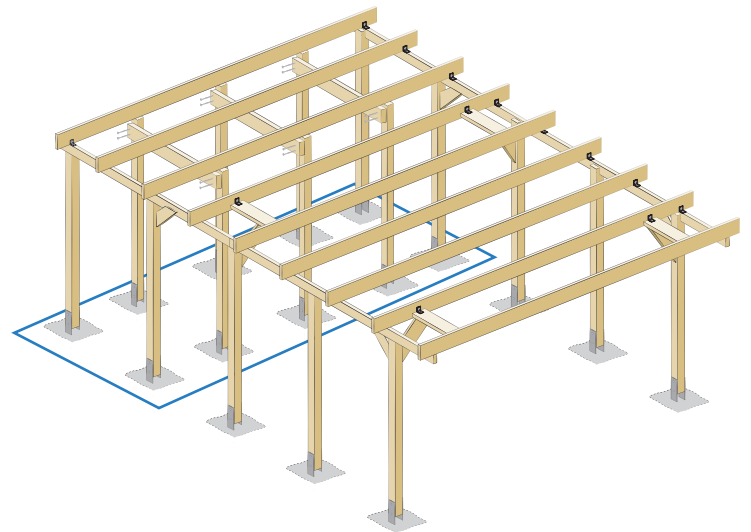

**Genauere Maße siehe Zeichnung.
Pour les dimensions exactes,
consultez le plan ou dessin.
Misura esatta vedi disegno.
Para conocer las dimensiones
exactas, ver dibujo.**

B

2. Montage

Montage
Montaggio
Montaje

25		3 x
26		1 x
28		16 x
34		32 x
35		32 x

31		1 x
32		2 x
33		1 x
35		24 x

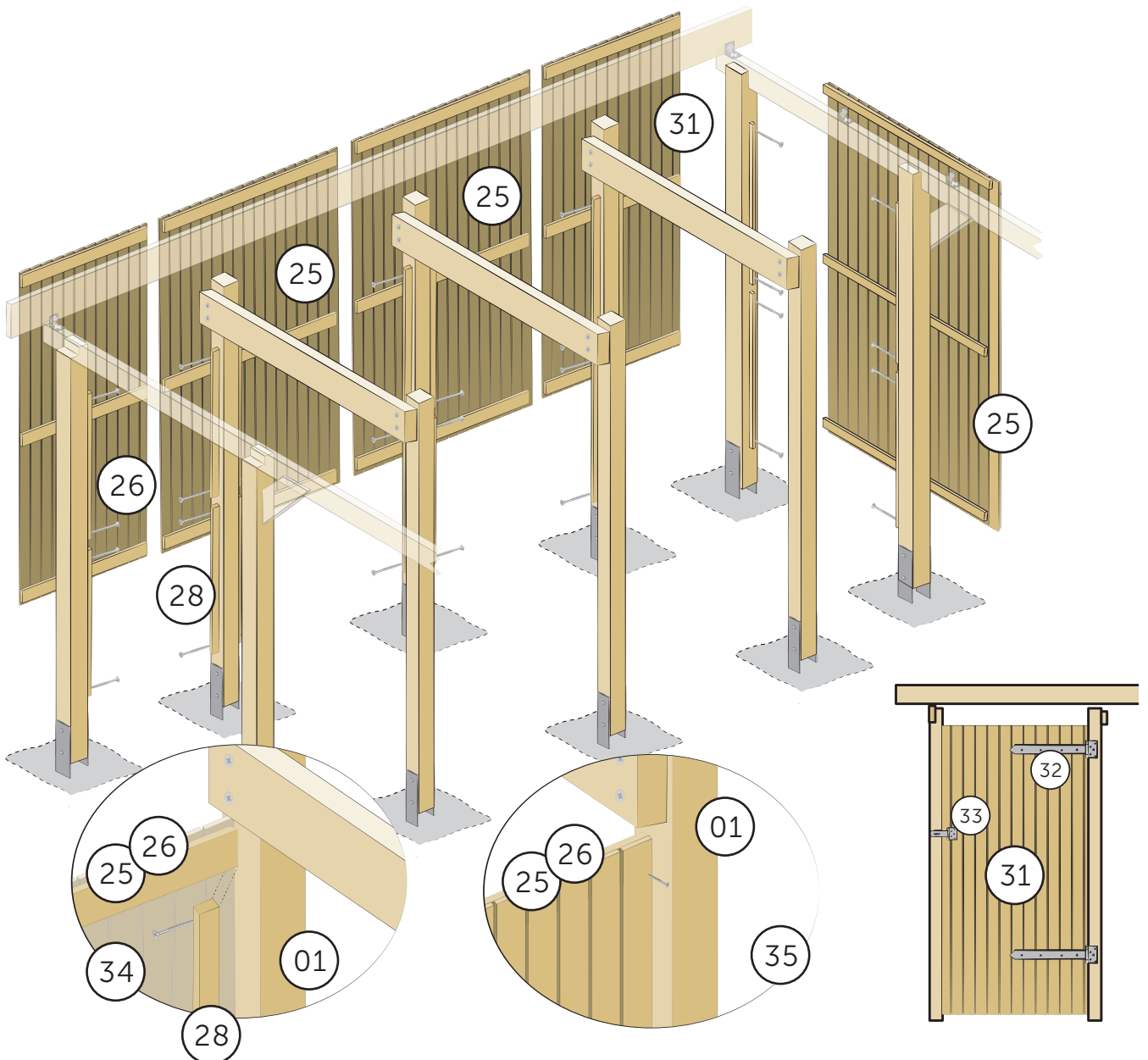

3. Montage

Montage
Montaggio
Montaje





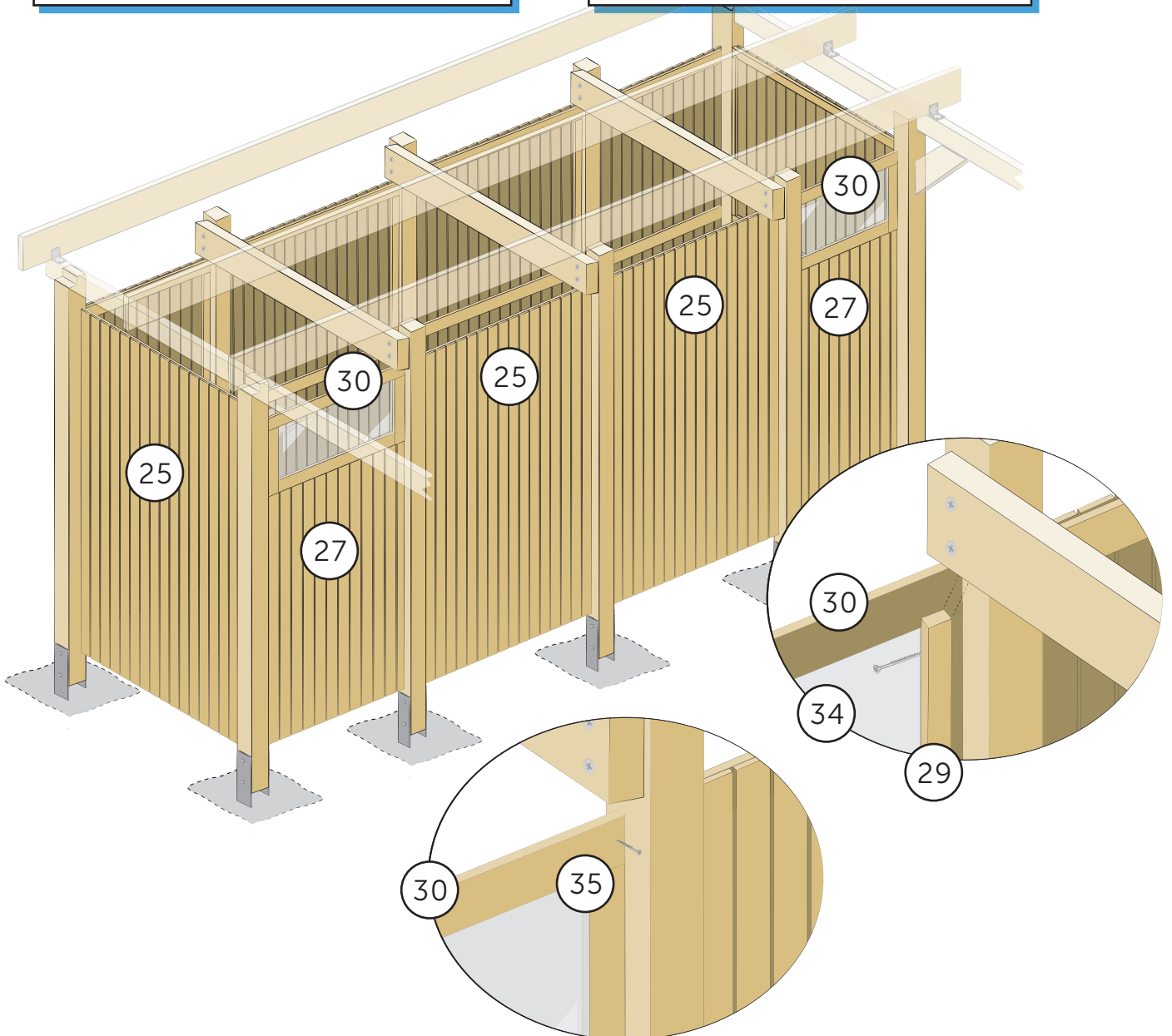



25		3 x
27		2 x
28		16 x
34		32 x
35		32 x

30		2 x
29		4 x
34		8 x
35		8 x

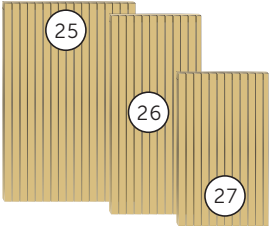

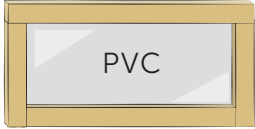
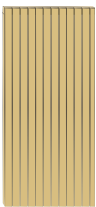
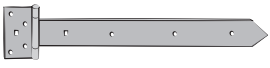
Teileliste / Liste de pièces / Distinta pezzi / Lista de piezas

Gerätekammer KH 103 / KH 105 5,51 x 1,73 m

Pos.		Dimensionen mm	Stück/ pieces	Kontrolle ✓ ✗
23		90 x 90 x 2100 mm	6	
24		60 x 160 x 1730 mm	3	
25		1500 x 1935 mm	6	
26		1010 x 1935 mm	1	
27		1010 x 1500 mm	2	
28		35 x 50 x 863 mm	32	
29		35 x 50 x 427 mm	4	
30		1010 x 435 mm	2	
31		1000 x 1935 mm	1	
32		350 mm	2	
33			1	
34		5 x 90 mm	84	
35		5 x 40 mm	96	

Garantie-Nummer / numéro de garantie
 Codice di garanzia / número de garantía

Ihre Lieferanschrift / Votre adresse de livraison / Indirizzo di consegna /
 Su dirección de entrega
 Name: _____
 Adresse: _____
 Tel: _____

IHRE GARANTIE-NUMMER EINTRAGEN:
siehe roten Aufkleber auf Verpackungsfolie

ENTREZ VOTRE NUMÉRO DE GARANTIE :
voir les autocollants rouges sur le film d'emballage

INSERIRE IL CODICE DI GARANZIA: vedi adesivo rosso sulla pellicola d'imballaggio

INDIQUE SU NÚMERO DE GARANTÍA: ver la etiqueta roja sobre el embalaje transparente

Ihre Garantie-Nummer: Aufbewahren!!
Votre numéro de garantie : Conserver en lieu sûr !!
Codice di garanzia: Conservare!!
Su número de garantía: ¡Conservar en lugar seguro!

