



Create amazing spaces™

MANUAL

DARWIN 6x4

UPUTE ZA POSTAVLJANJE



SKU: 17210351 | 17210352

A-1582.5006836



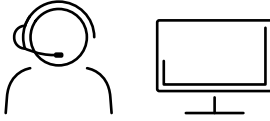

WWW.KETER.COM

US, Canada
Tel: +1877-638-7056, NACS@keter.com

UK
Tel: +44-121-506-0008, CSUK@keter.com

Za ostale europske zemlje pogledajte zadnju stranicu.

AKTIVIRANJE JAMSTVA

Zahvaljujemo se na kupnji Keter vrtno kućice. Kako biste aktivirali jamstvo, prijavite se na našu webstranicu i ispunite obrazac pod naslovom aktiviranje jamstva (Warranty activation).

PRIPREMA PODLOGE

Poravnajte površinu zemlje

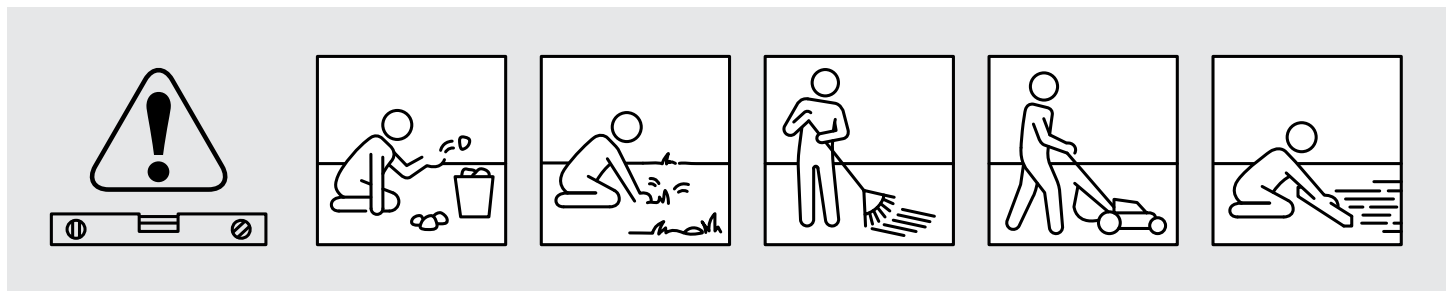

Savjet: Napravite temelj od cementa ili drveta.

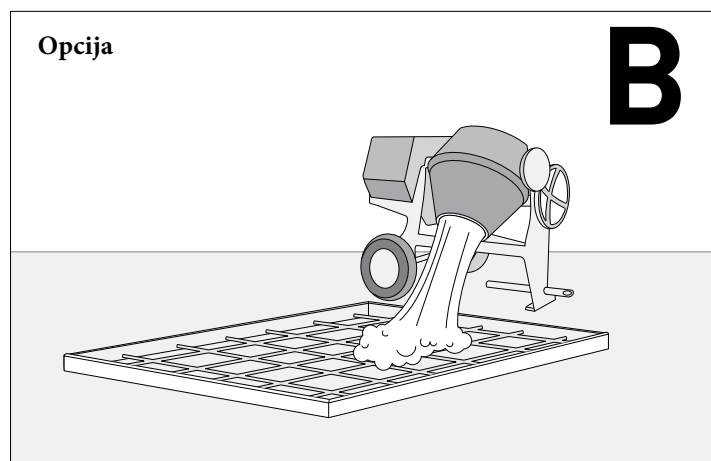
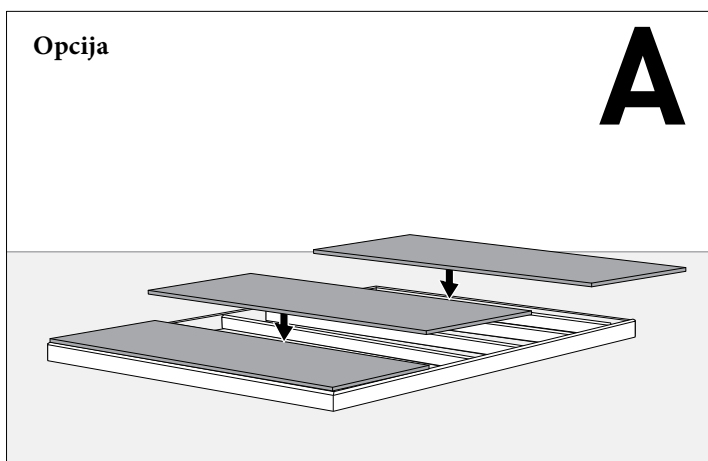

Pazite da ostavite dovoljno prostora oko kućice na mjestu postavljanja kako biste mogli pristupiti kućici sa svih strana tijekom montaže.

Vanjske dimenzije podnožja iznose:

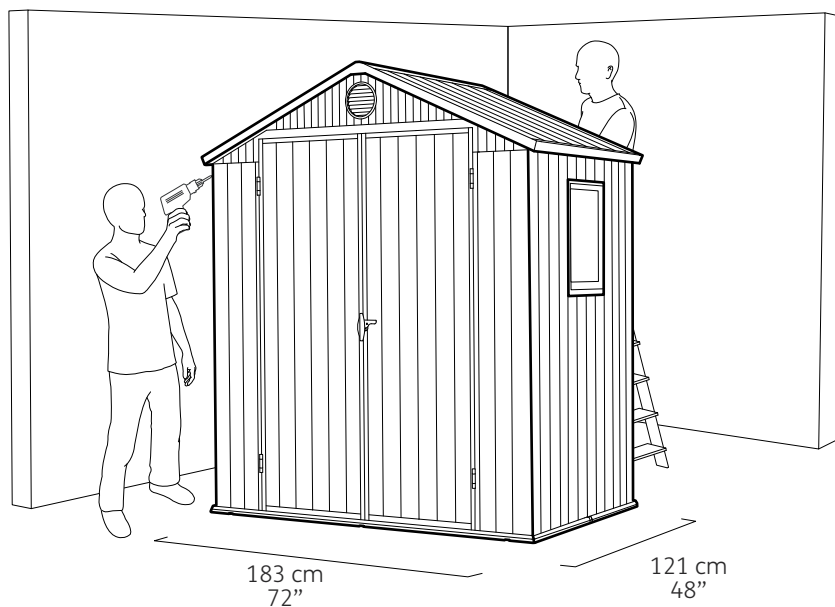

PRIJE POČETKA MONTAŽE

Pažljivo pročitajte sigurnosne smjernice, koje se nalaze na kraju ovih uputa za postavljanje. Provjerite PRIJE postavljanja jesu li svi dijelovi na broju i jesu li oštećeni. Izvadite sve dijelove iz pakiranja i postavite ih na čistu radnu površinu. Pregledajte još jedanput cijele upute za postavljanje. Spojite sve dijelove kako je opisano u ovim uputama. Ne preskačite korake.

POTREBNI ALAT

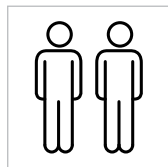
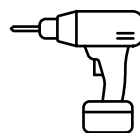
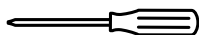
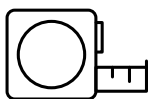

POTREBNE SU DVIJE OSOBE ZA POSTAVLJANJE.

Pakiranje može sadržavati neke dodatne sitne dijelove koji se mogu koristiti kao zamijenski dijelovi.

NAPOMENA: Zbog varijacija u proizvodnji, stvarne dimenzije sastavljene kućice mogu odstupati od navedenih dimenzija.

DIJELOVI KUĆICE

Izvadite sve dijelove iz pakiranja i posložite ih na čistu ravnu površinu. Svaki dio je označen brojevima za lakšu identifikaciju.

DIJELOVI PODNICE

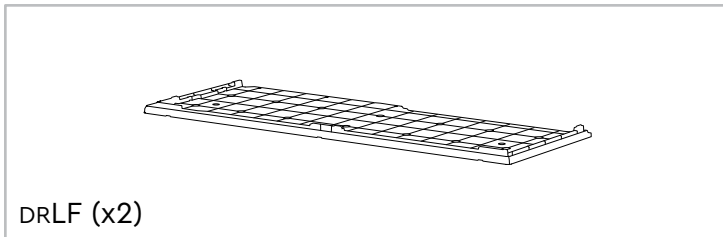

DIJELOVI ZIDA

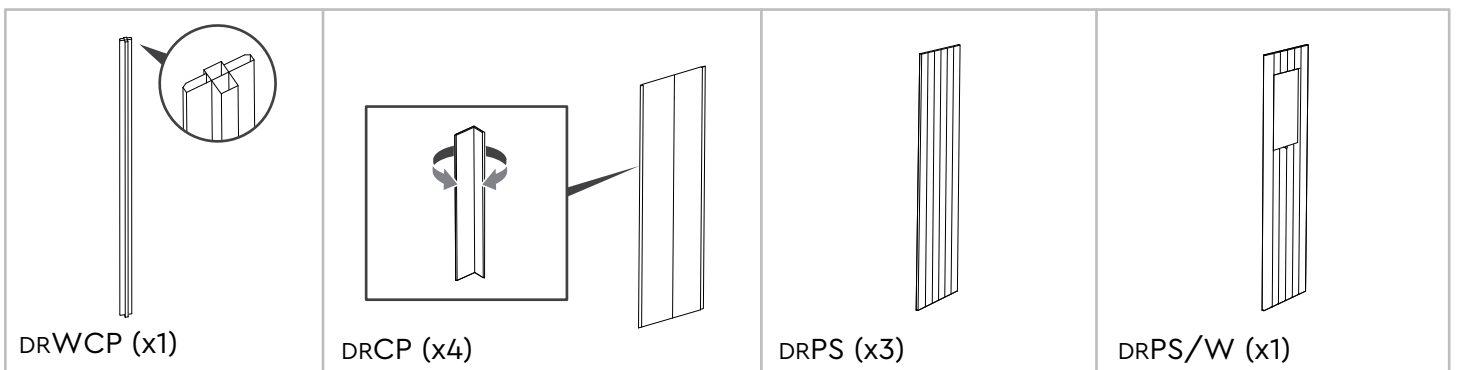

DIJELOVI KROVA

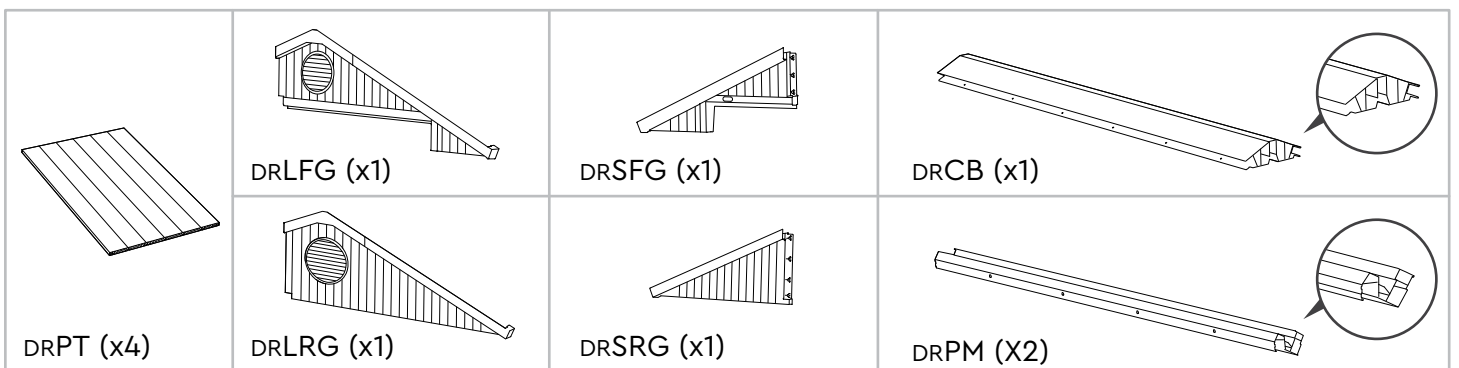





DIJELOVI VRATA

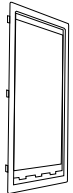
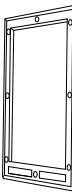
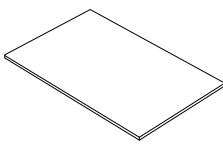



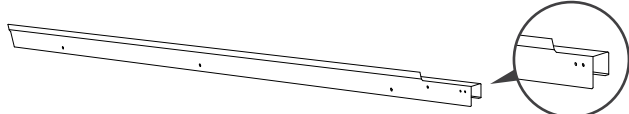

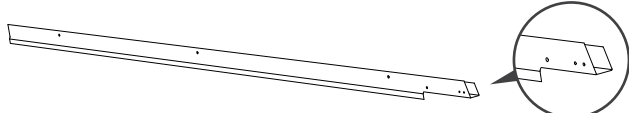
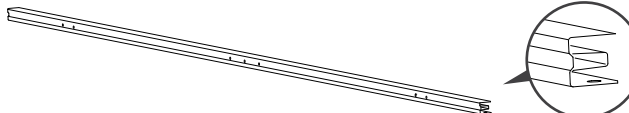
DIJELOVI PROZORA

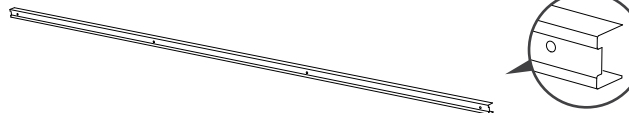
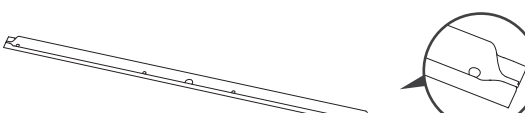
 <p>WI-OUT (x1)</p>	 <p>WI-IN (x1)</p>	 <p>MDG (x1)</p>
--	---	---

METALNI DIJELOVI

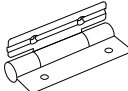
 <p>DRDML (x1)</p>	 <p>DRMDT (x2)</p>
 <p>DRDMR (x1)</p>	 <p>DRMA (x3)</p>
 <p>DRMTF (x1)</p>	 <p>DRMW (x1)</p>
 <p>DRWMP (x1)</p>	 <p>D6BP (x1)</p>

SITNI DIJELOVI

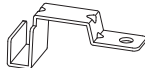
 <p>DRHG (x4)</p>	 <p>DRLM (x1)</p>	 <p>DRLH (x1)</p>	 <p>D6L (x2)</p>	 <p>DRCC (x4)</p>
--	--	--	---	--

VIJCI

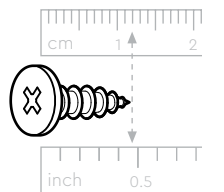
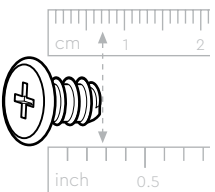
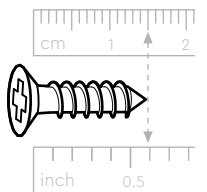
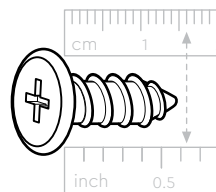
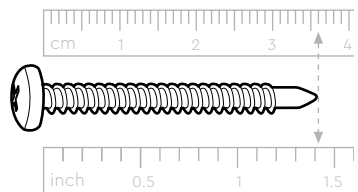
 <p>sc12t (x150) 12 mm / 0.47"</p>	 <p>sc7t (x12) 7 mm / 0.28"</p>	 <p>sw15d (x25) 15 mm / 0.6"</p>	 <p>sc15 (x7) 16 mm / 0.63"</p>	 <p>sc36 (x18) 36 mm / 1.42"</p>
--	--	---	---	---

POSTAVLJANJE PODNICE

1



DRLF (x2)

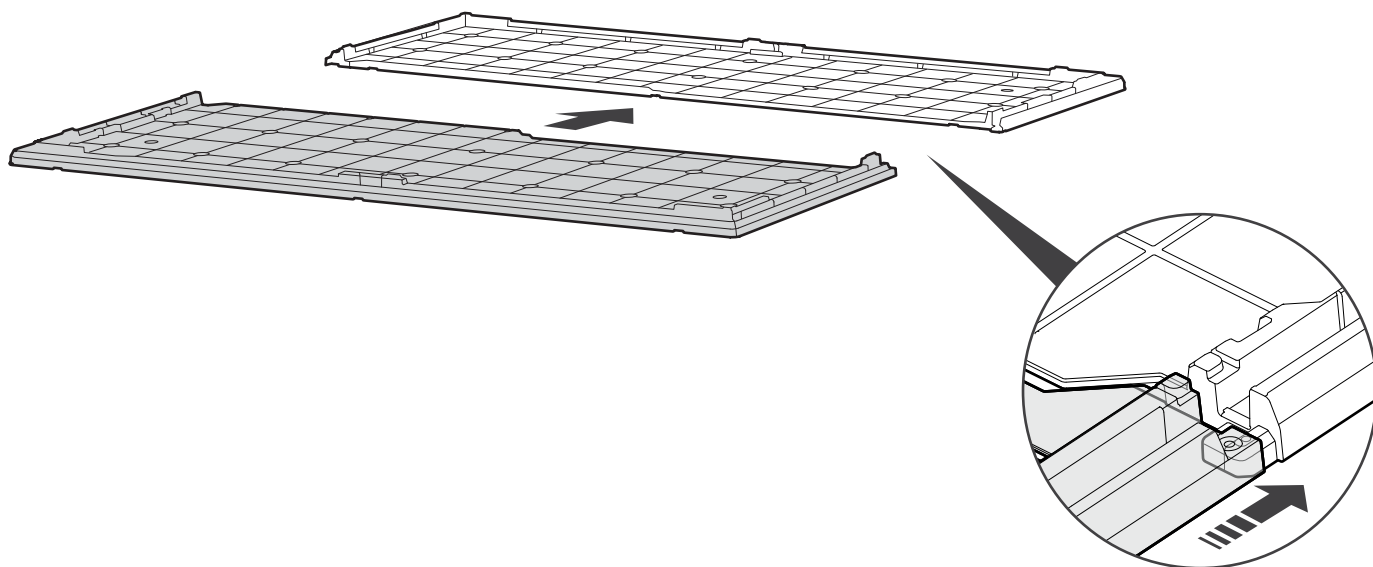
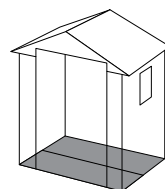

2



sc12t (x8)

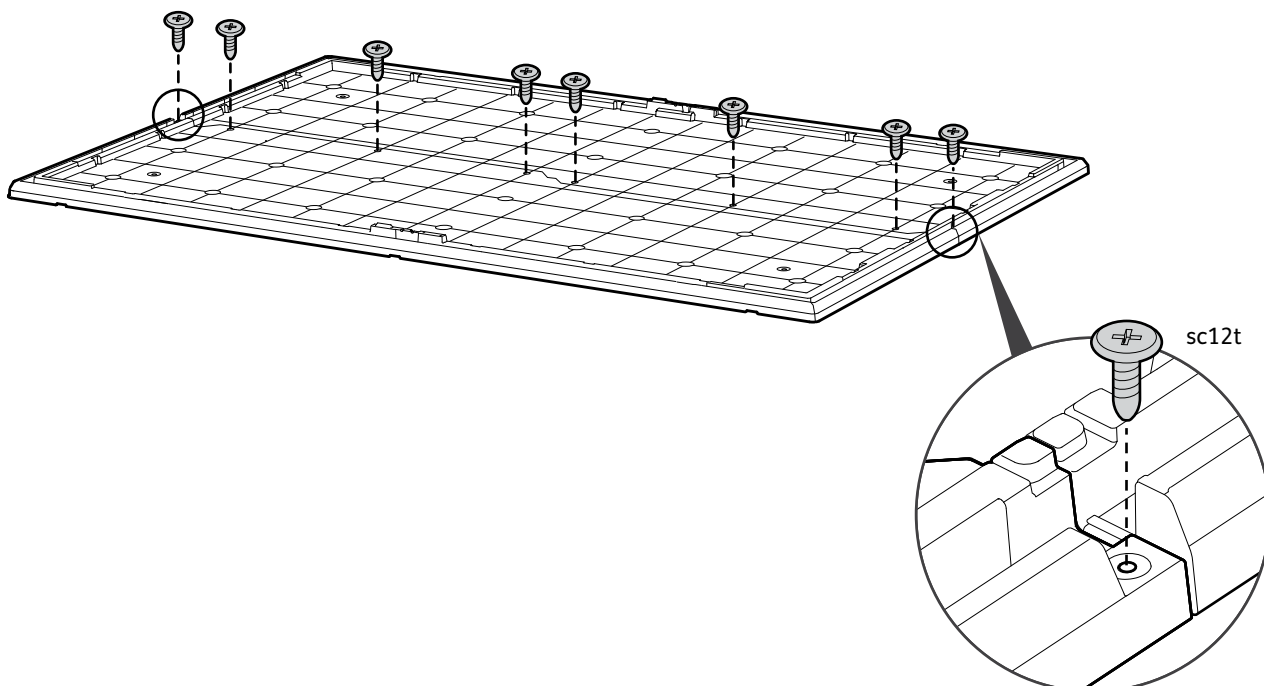
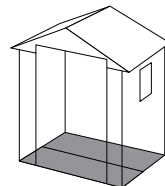

POSTAVLJANJE ZIDOVA

3



DRCP (x1)

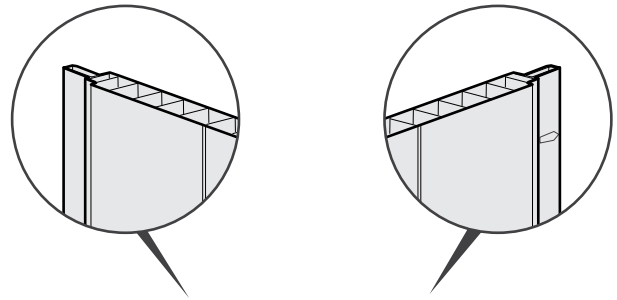
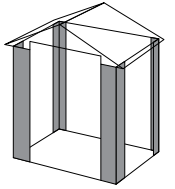
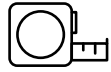

Asimetrično

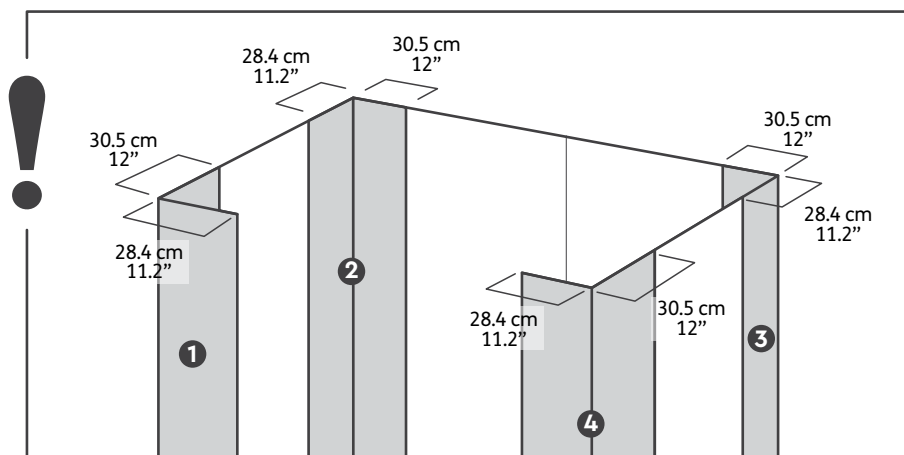
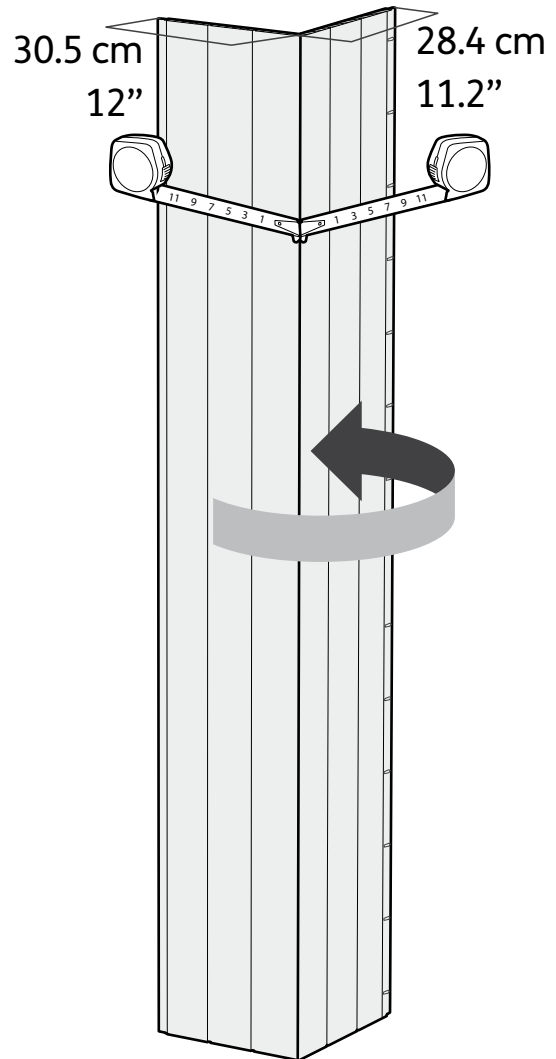

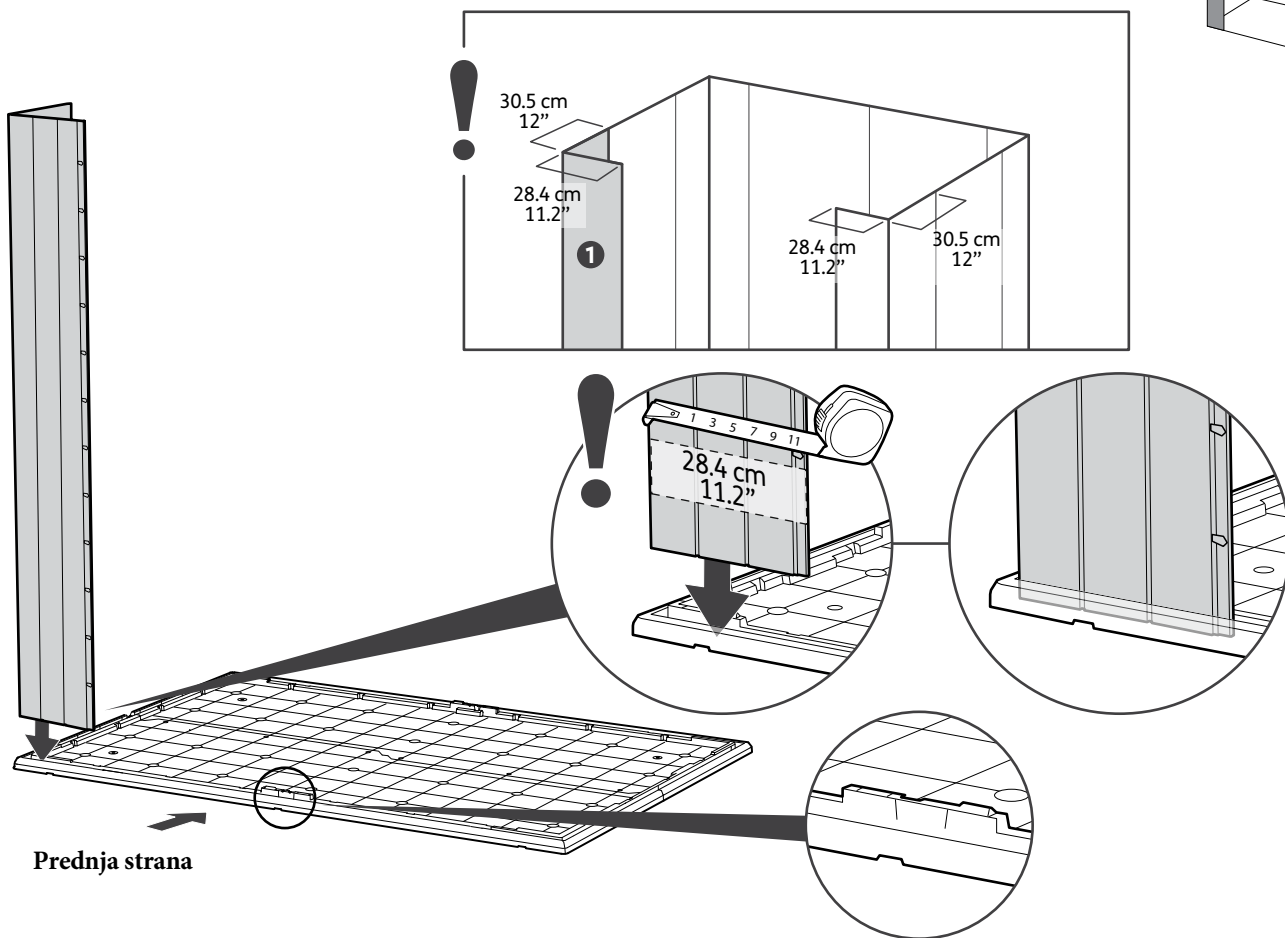
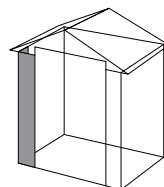

ODABERITE MJESTO GDJE ĆETE POSTAVITI PROZOR

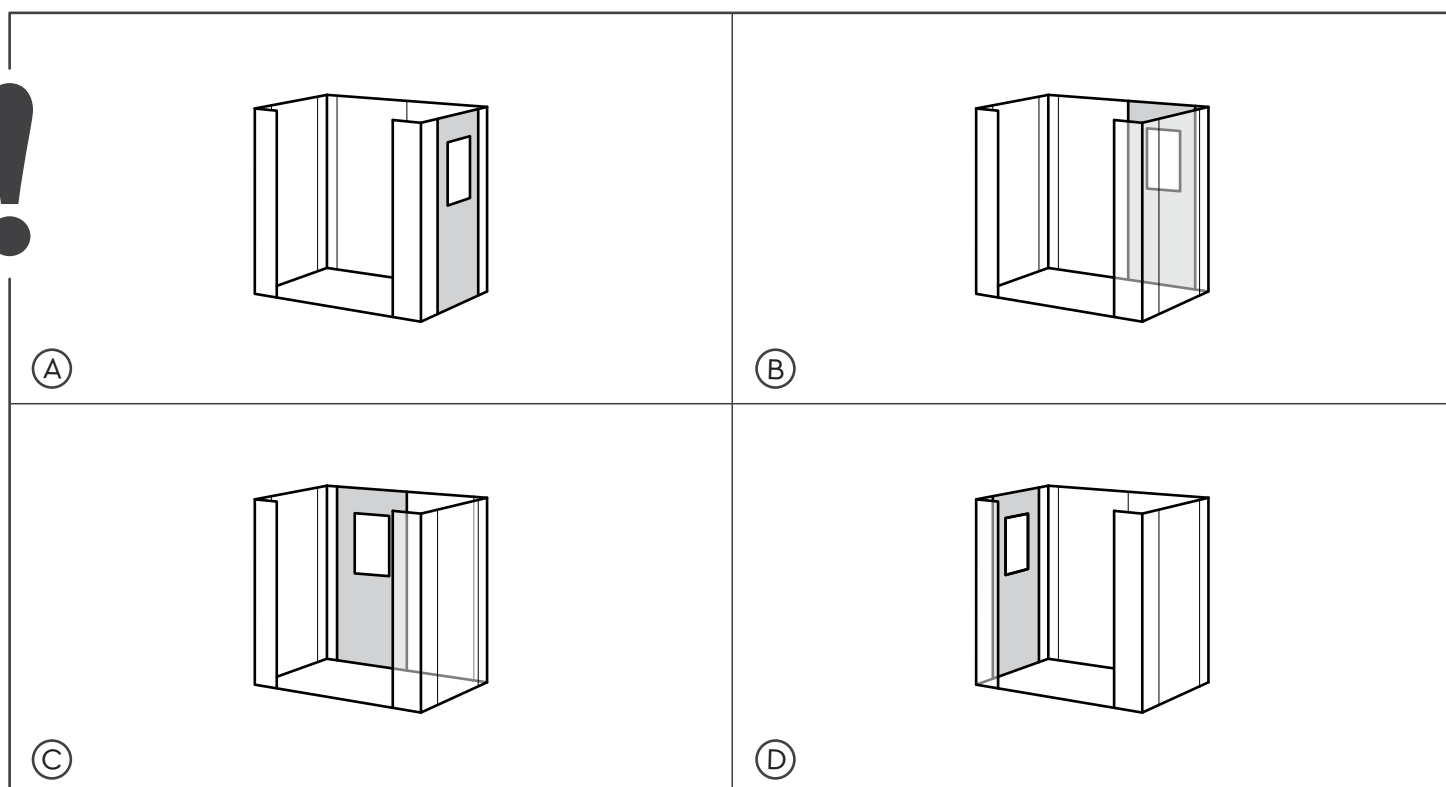

5



DRPS (x1)

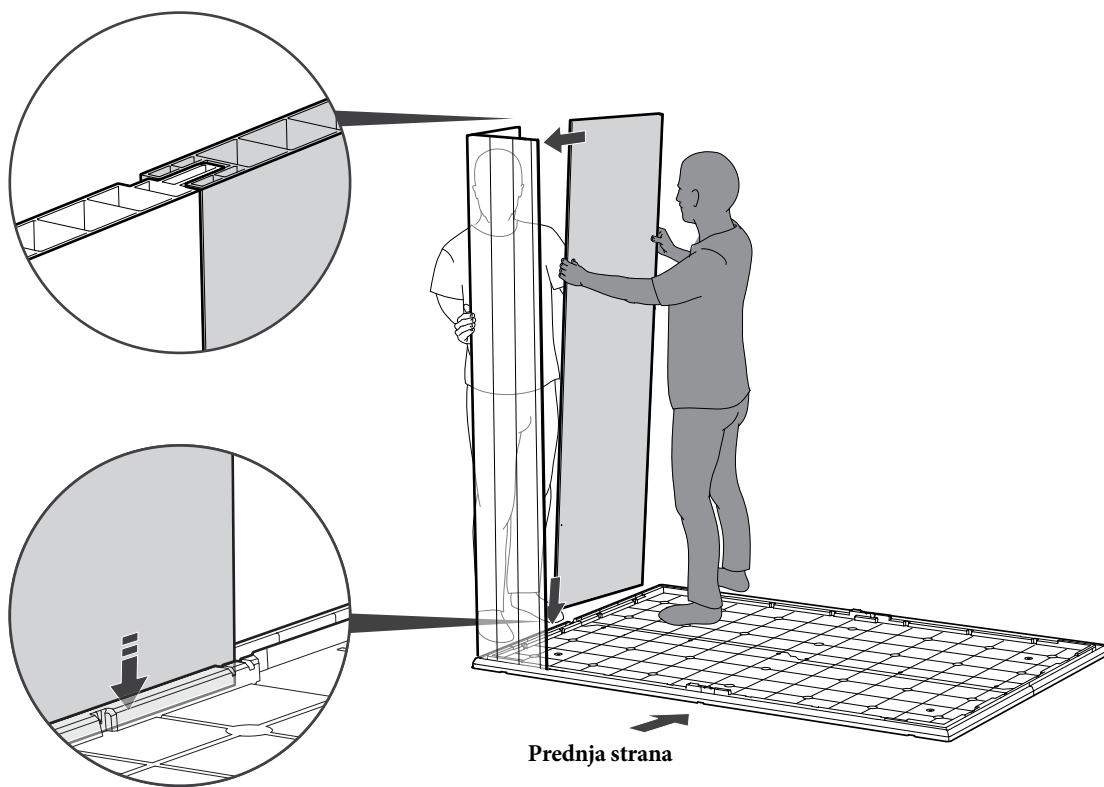
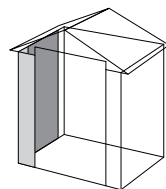

6



sc12t (x1)

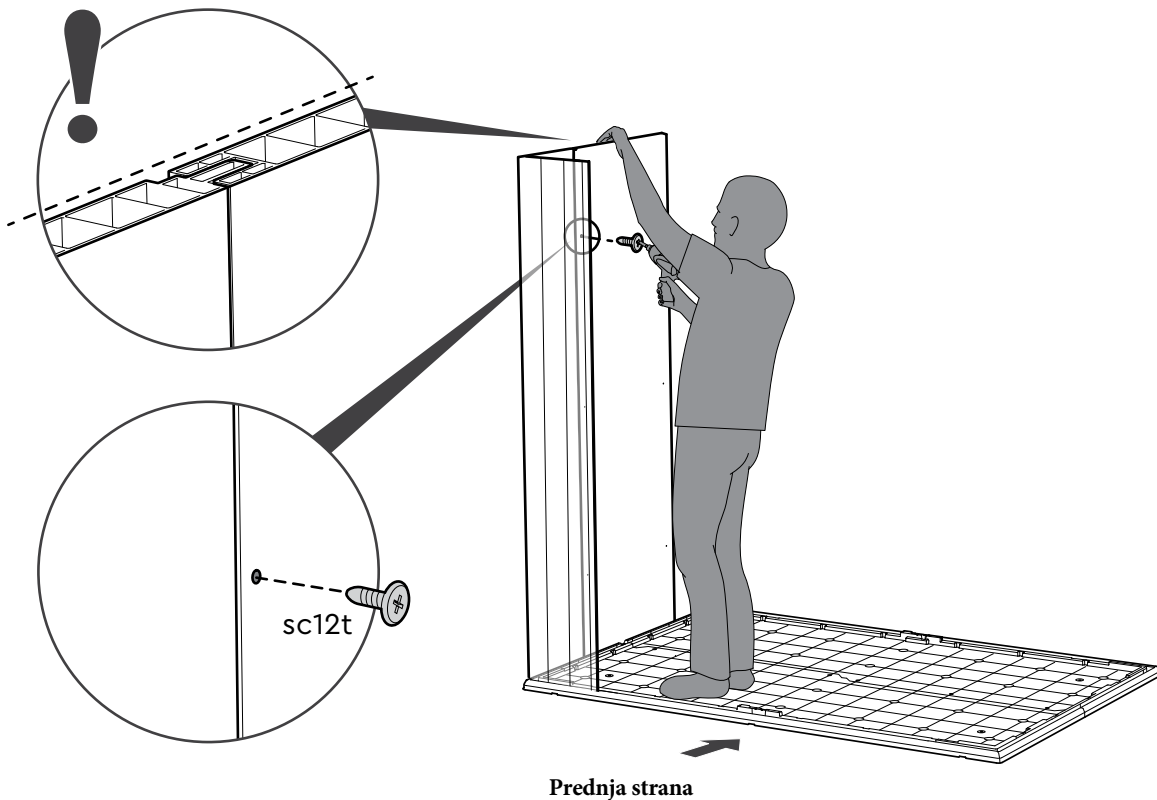
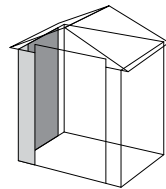

7

DRCP (x1)

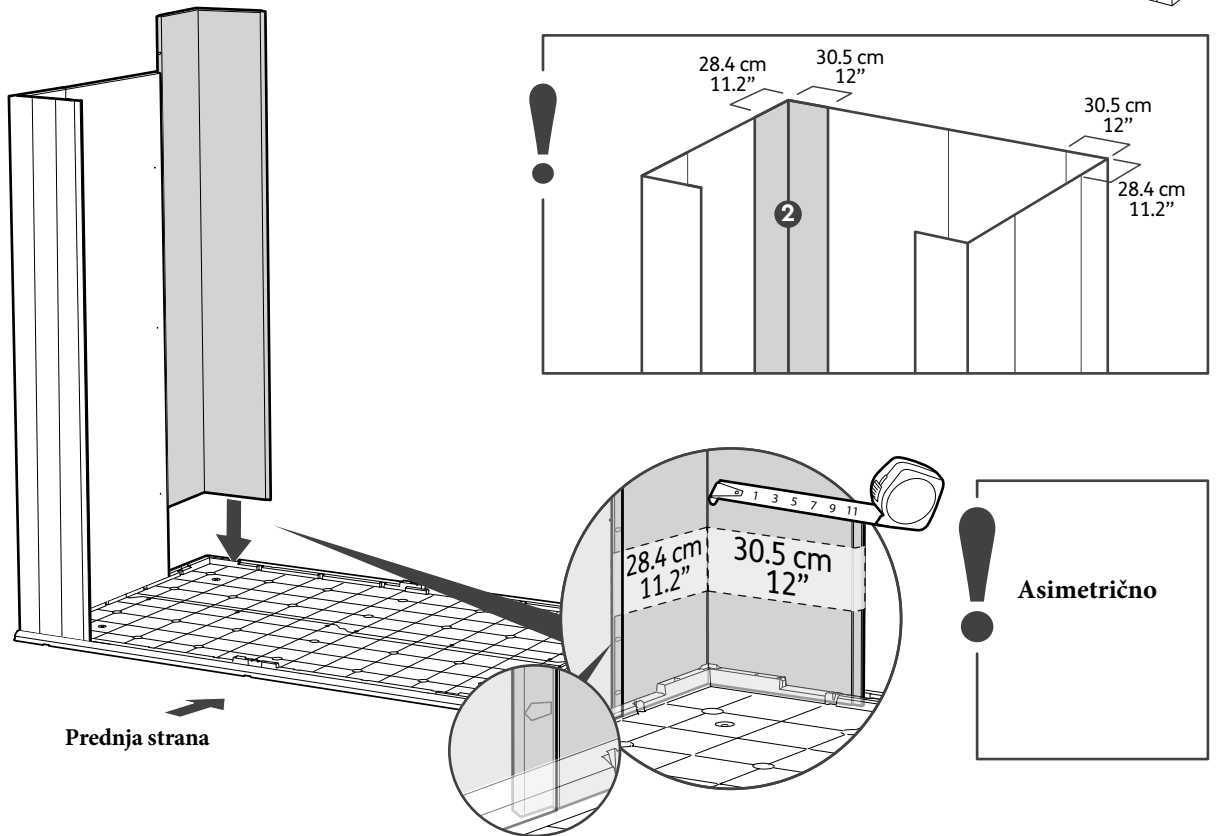
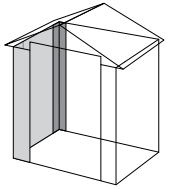

8



sc12t (x1)

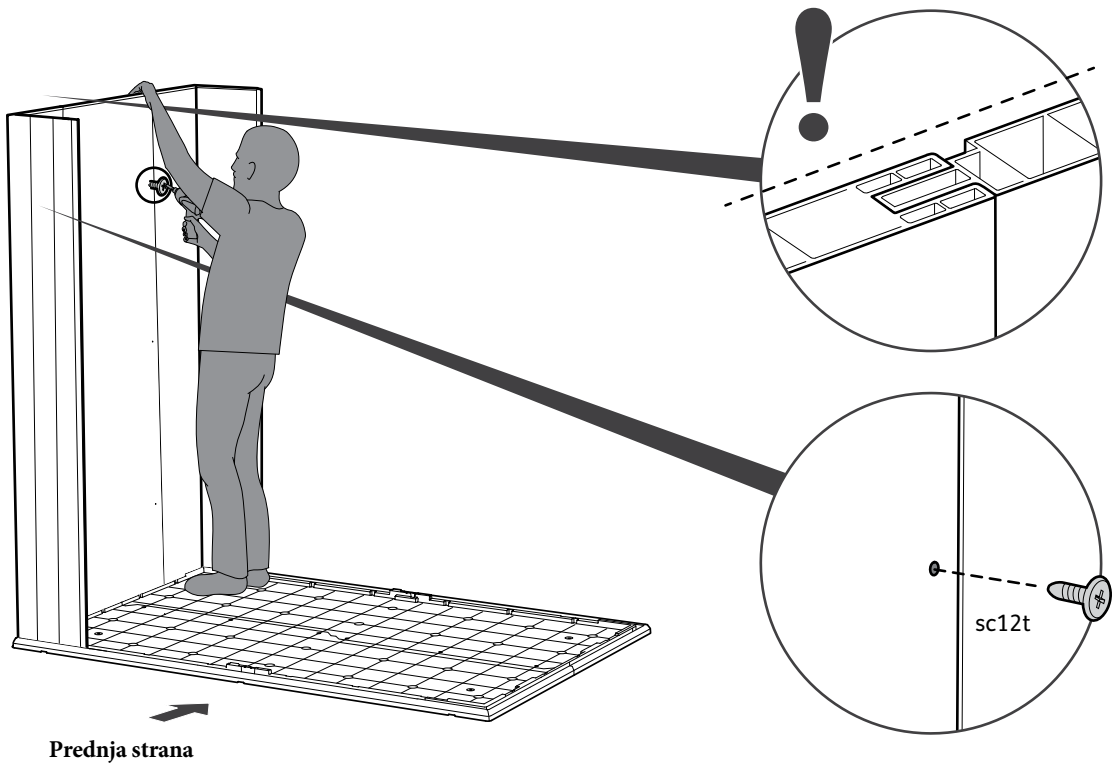
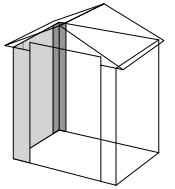

9



DRPS (x1)

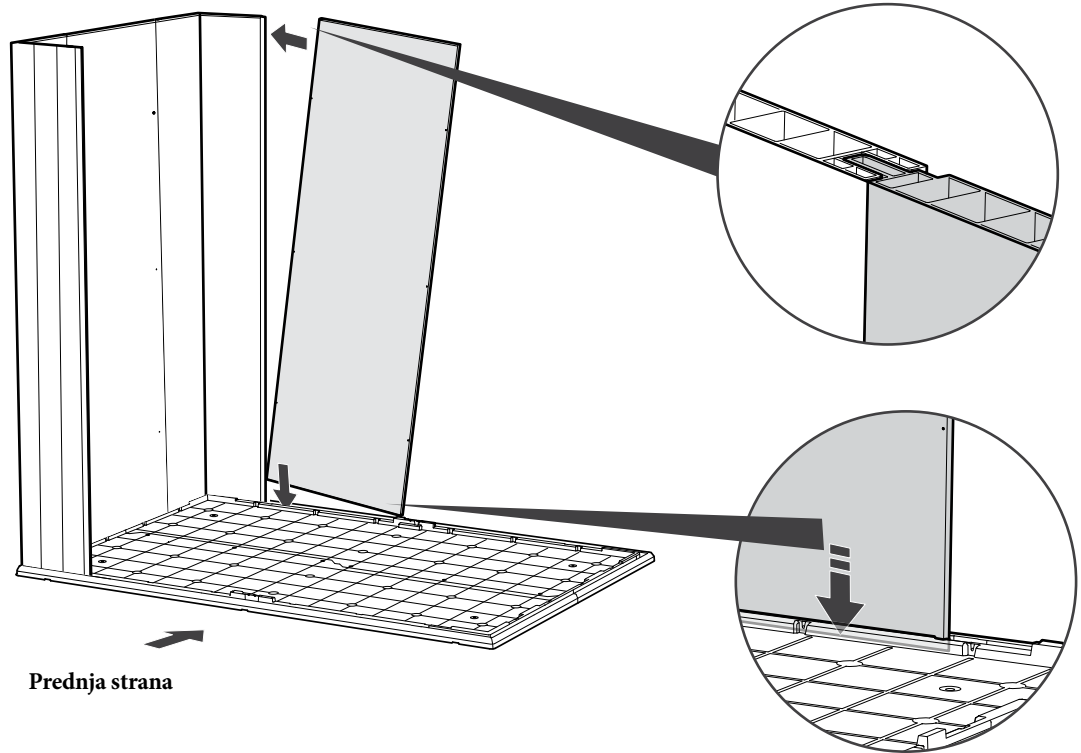
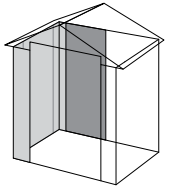

Prednja strana

10



sc12t (x1)

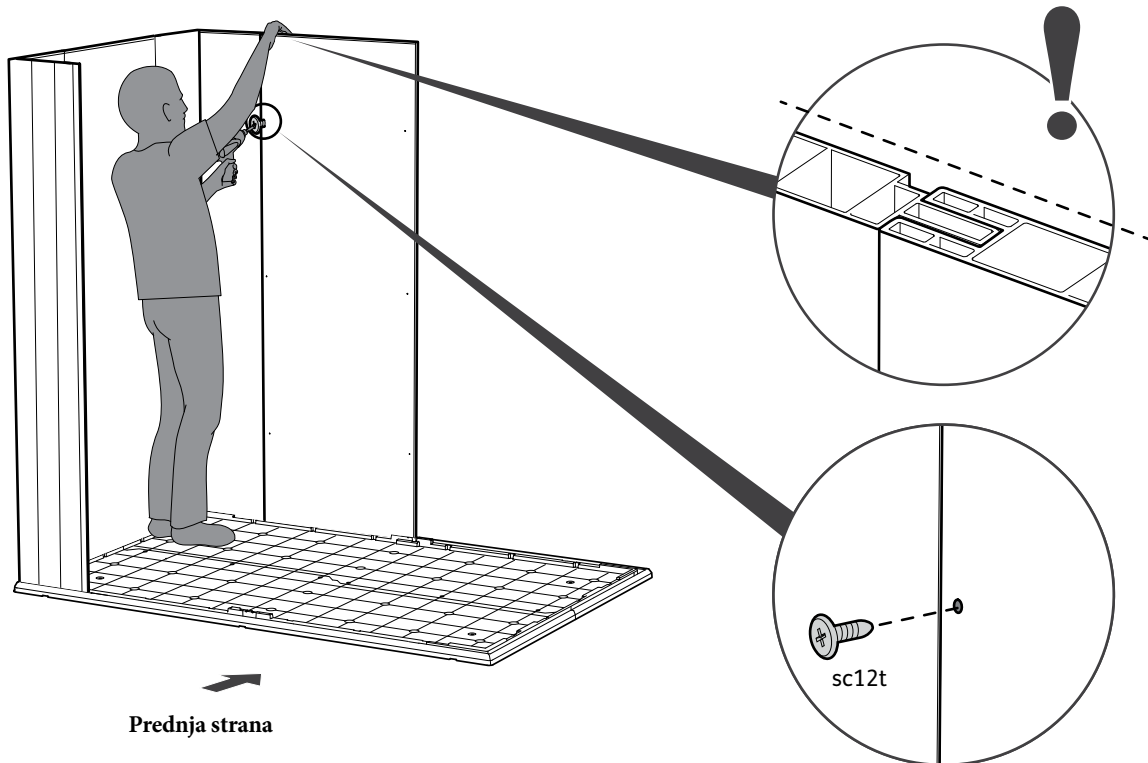
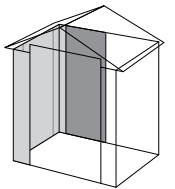

Prednja strana

11



DRWCP (x1)

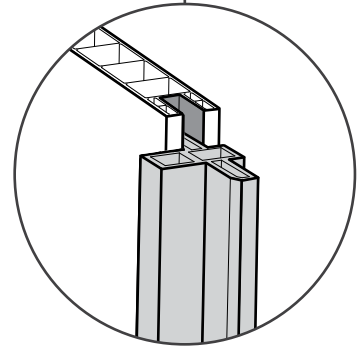
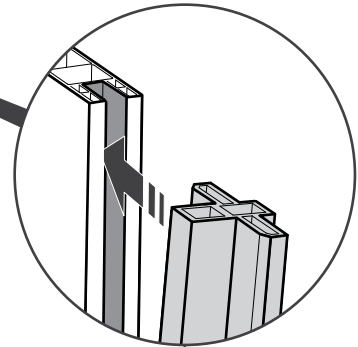
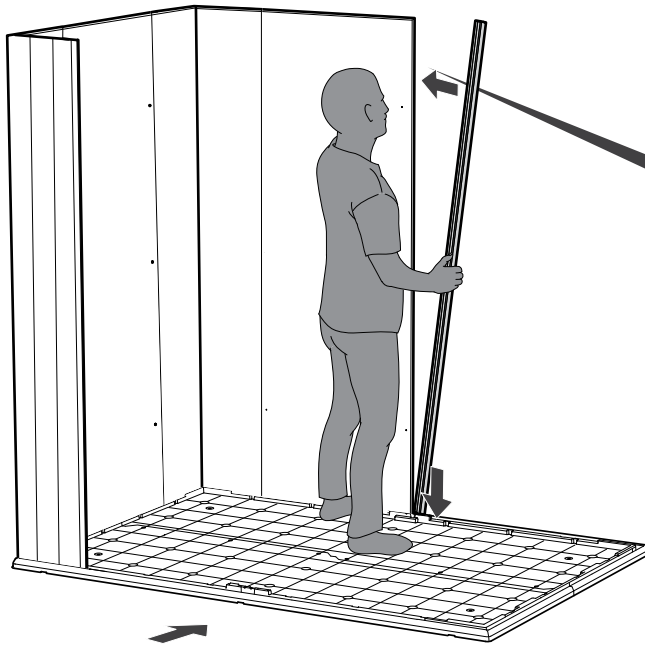
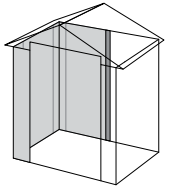

Prednja strana

12



sc12t (x1)

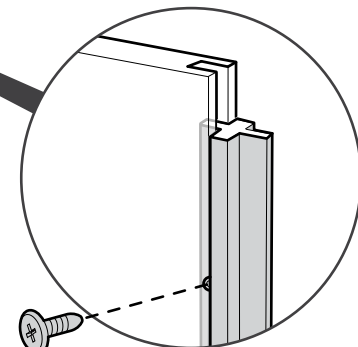
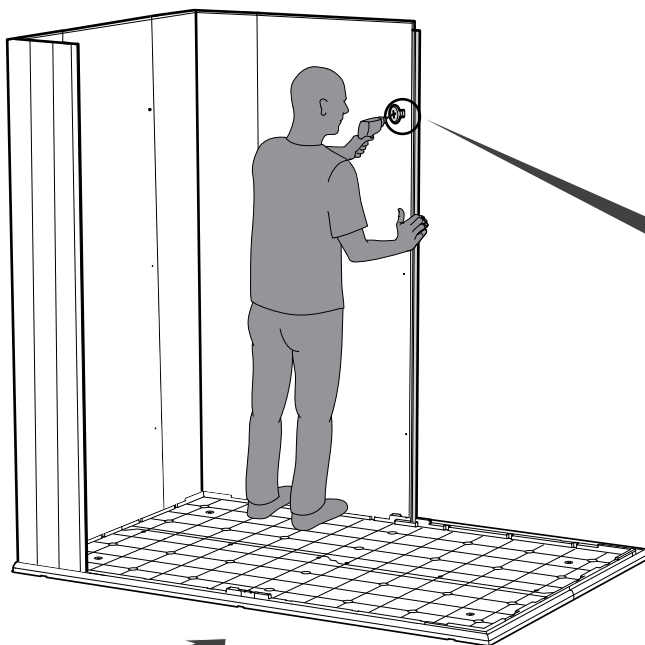
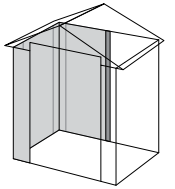

sc12t

Prednja strana

13



DRPS (x1)

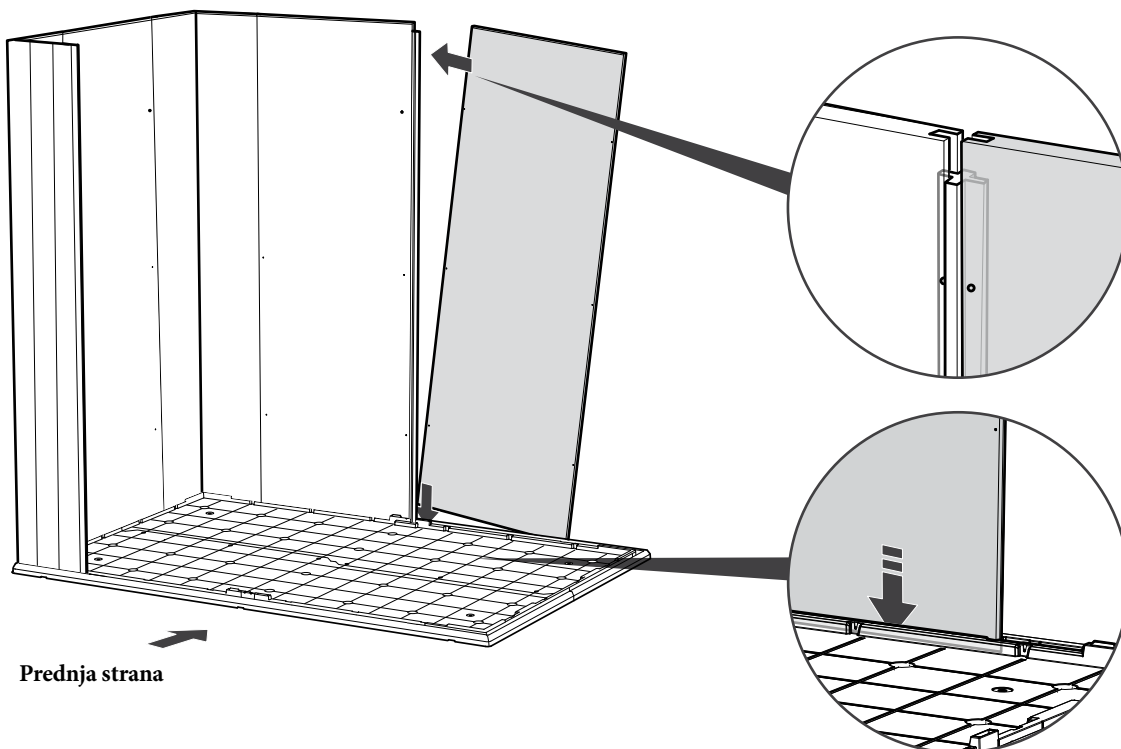
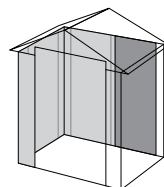

14



sc12t (x1)

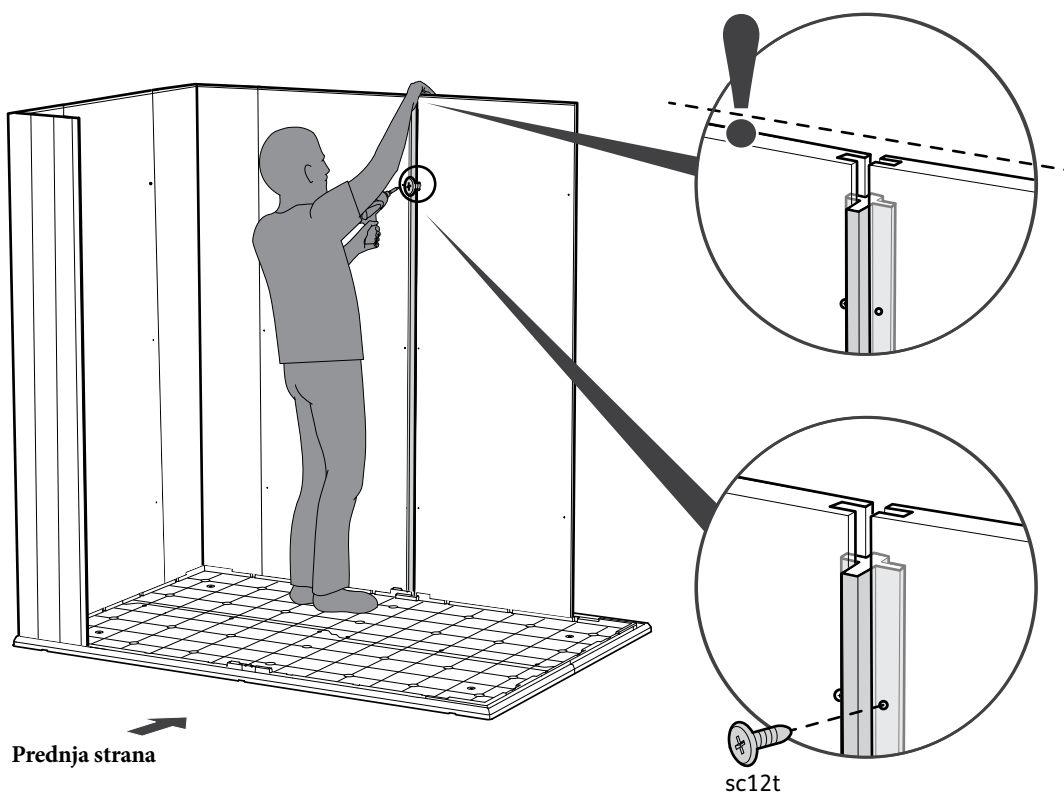
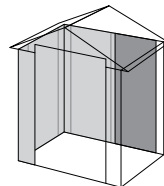

15

DRCP (x1)

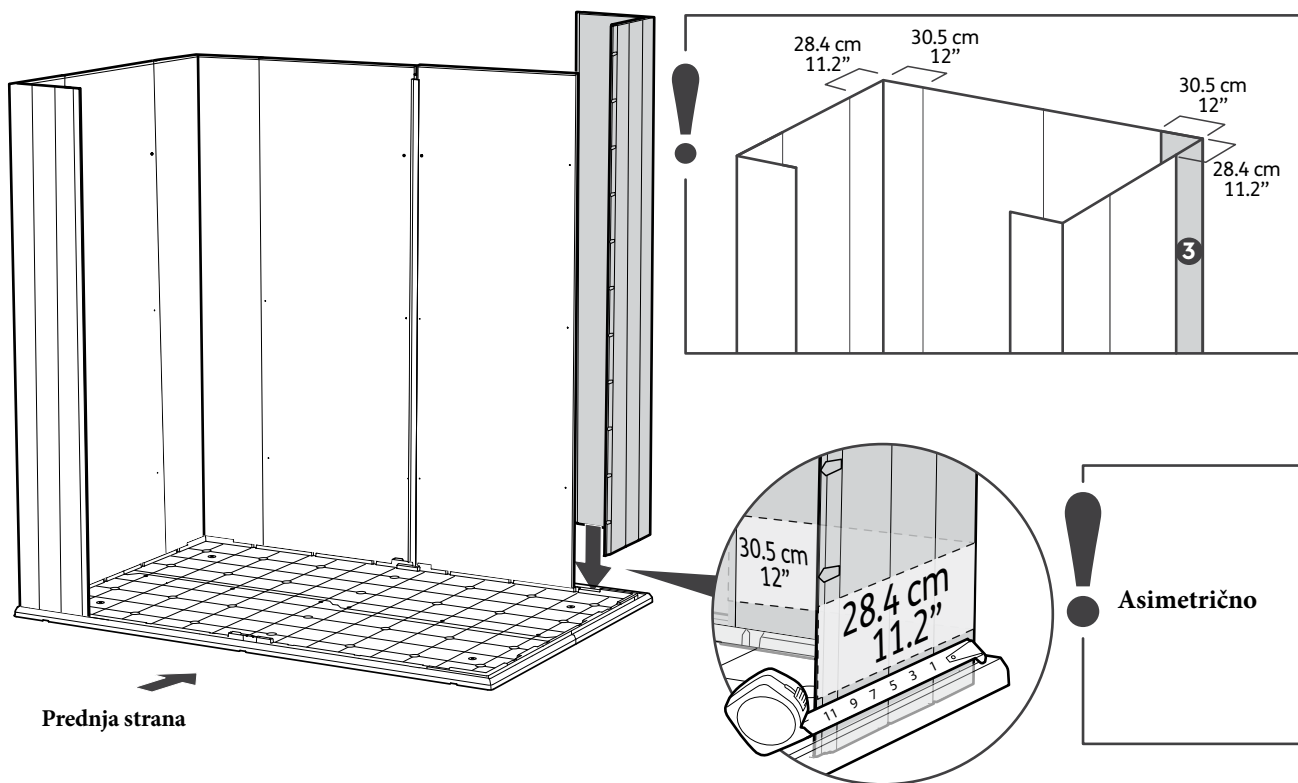
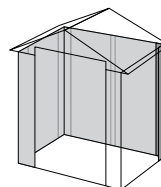

16



sc12t (x1)

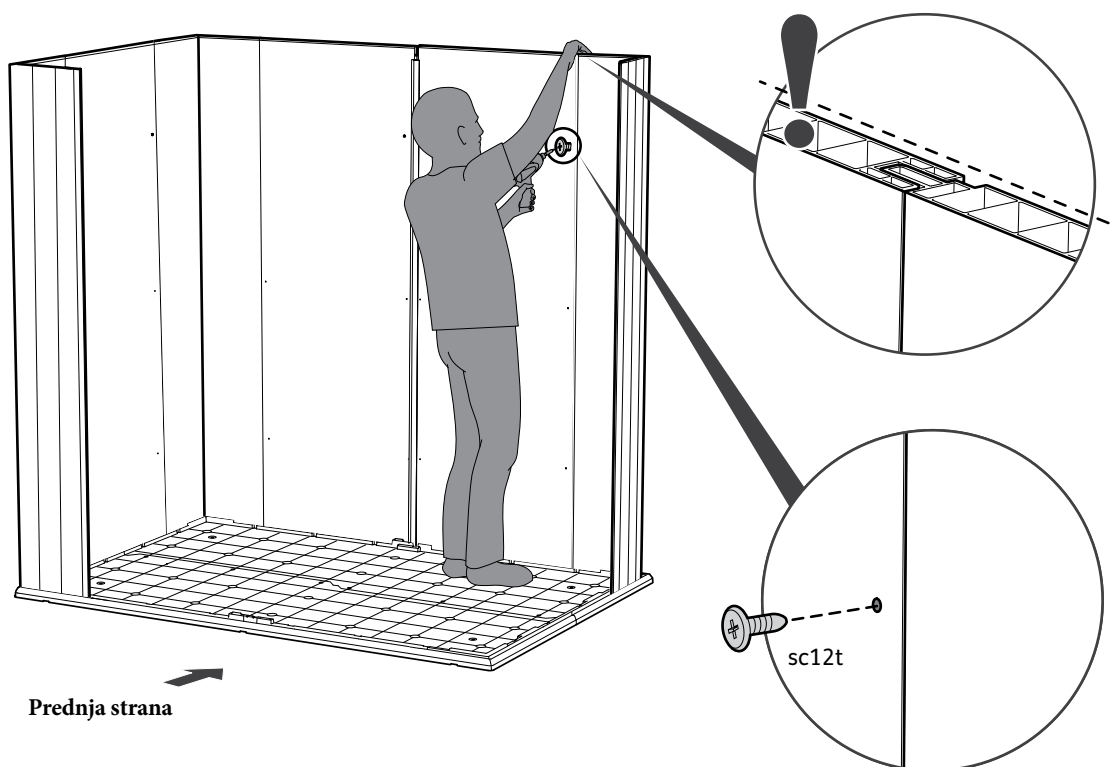
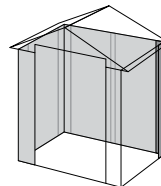

17

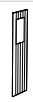

DRPS/W (x1)

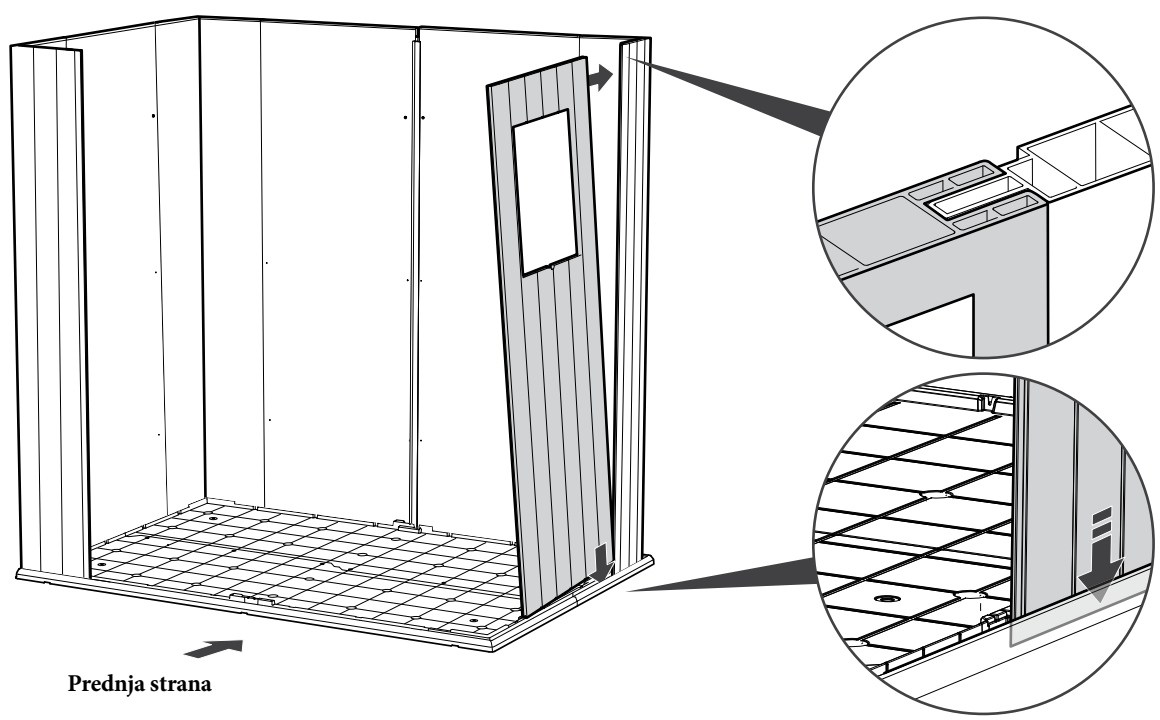
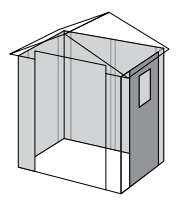

Prednja strana

18

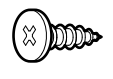

sc12t (x1)

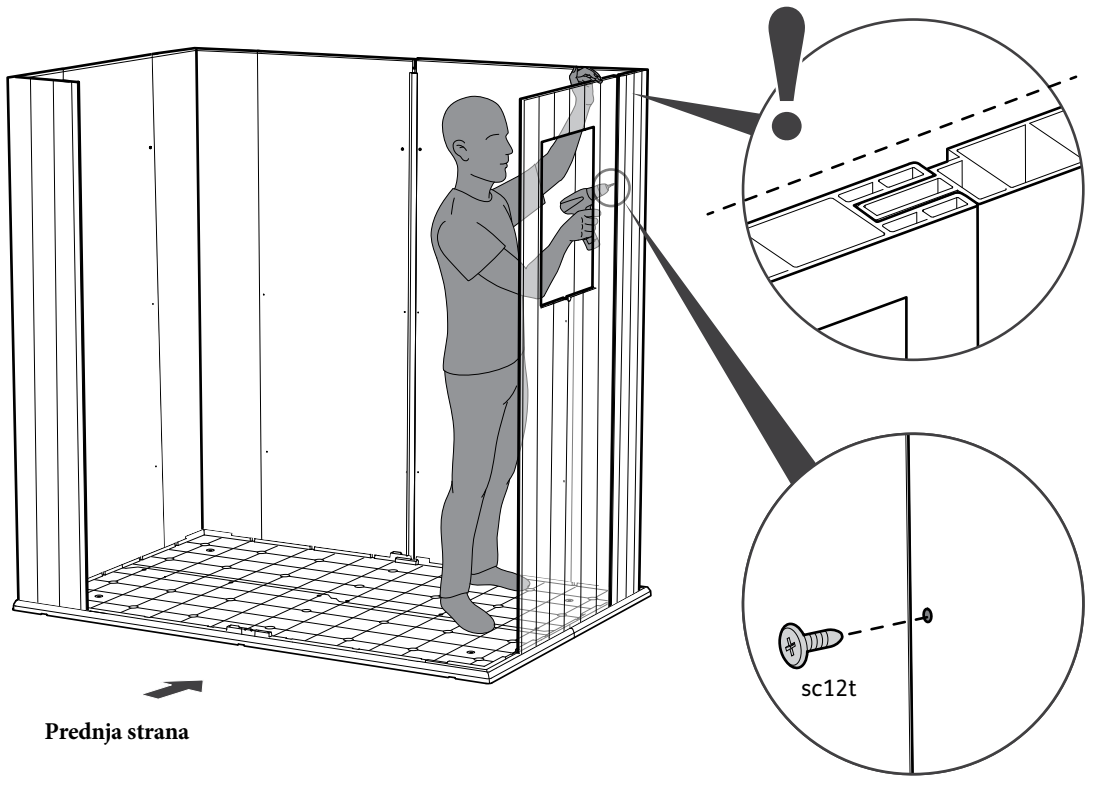
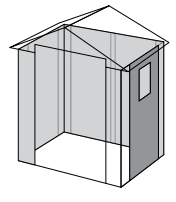

Prednja strana

19



DRCP (x1)

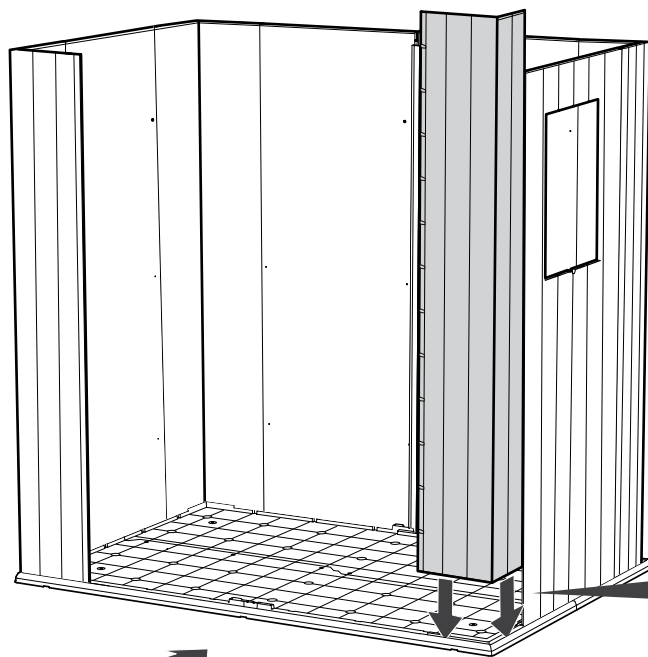
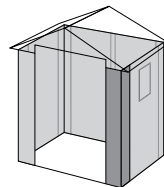

Prednja strana

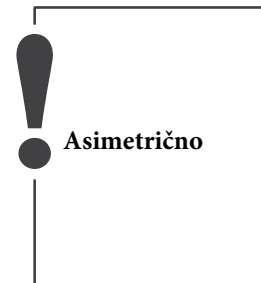
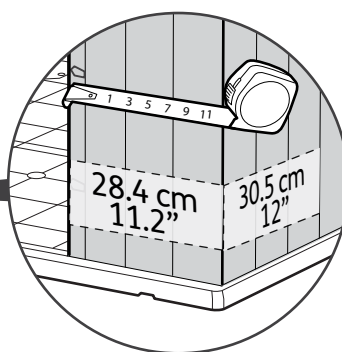
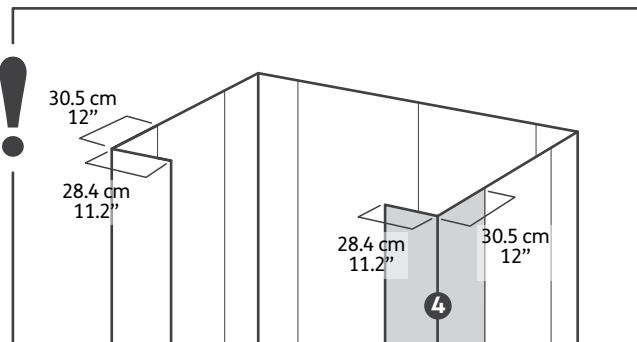

20



sc12t (x1)

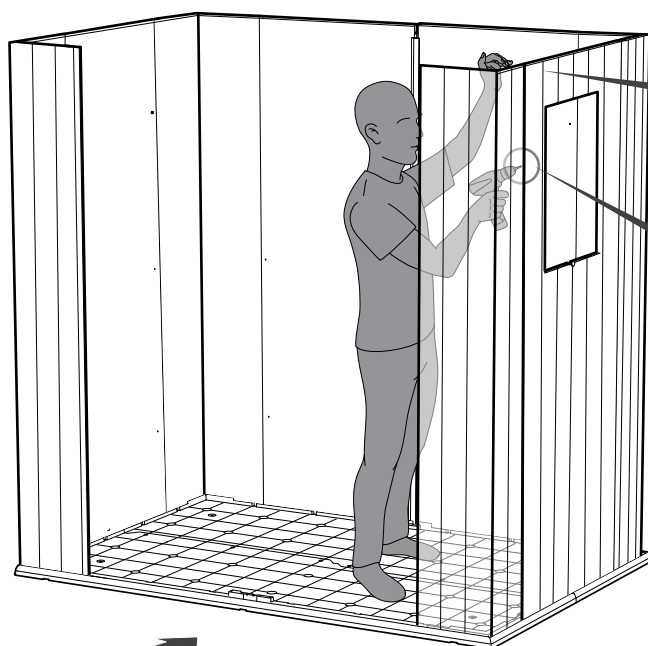
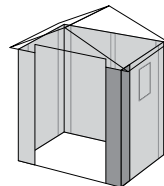

Prednja strana

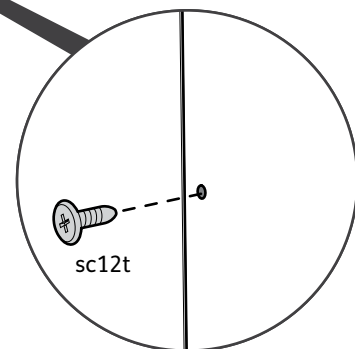
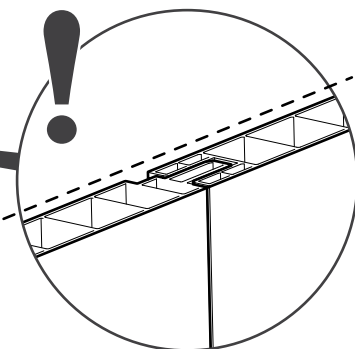

POSTAVLJANJE KROVA

21

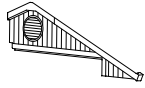

DRLFG (x1)

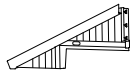

DRSGF (x1)



sc12t (x3)

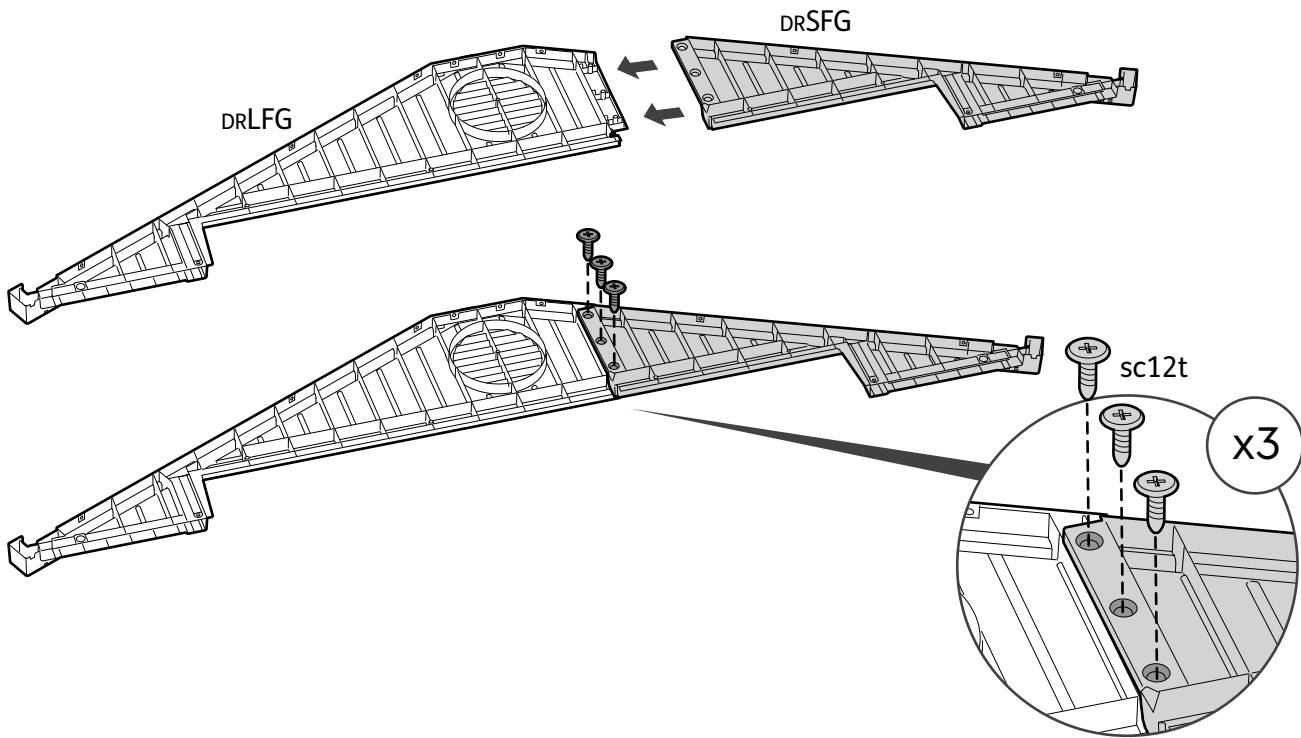
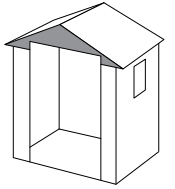

22



DRMTF (x1)



sc12t (x5)

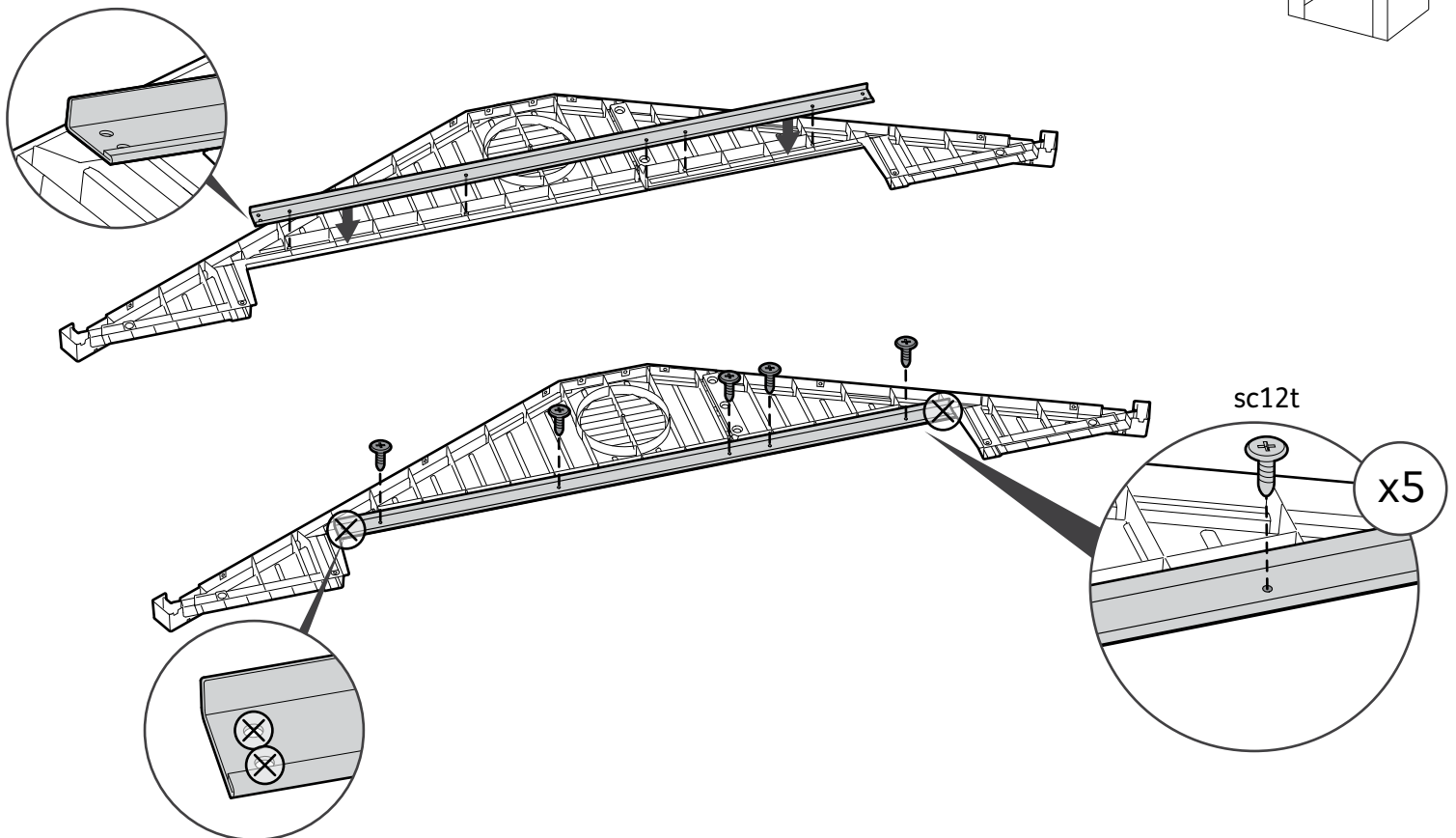
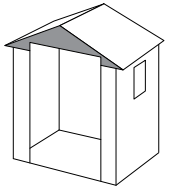

23

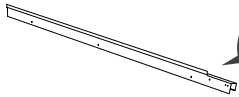

DRDML (x1)

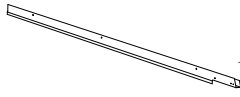

DRDMR (x1)

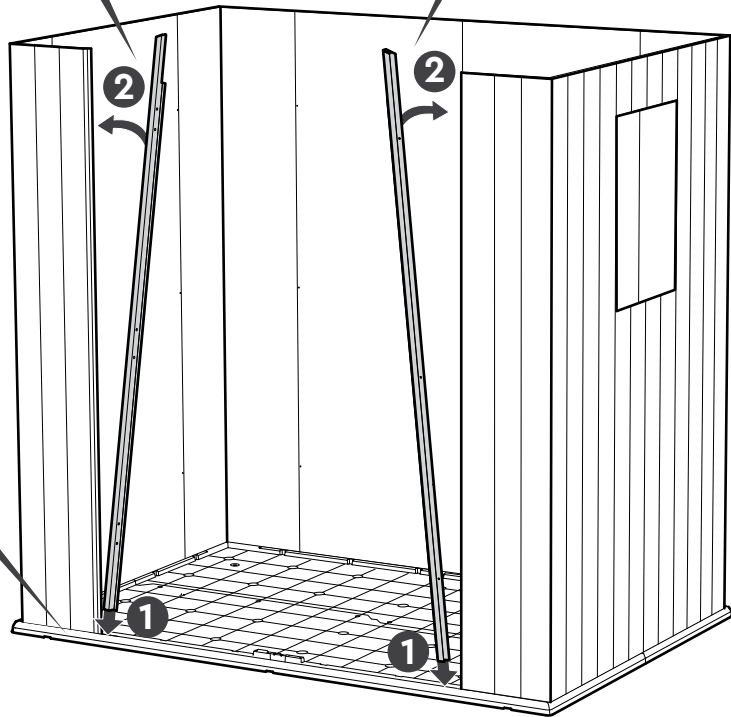
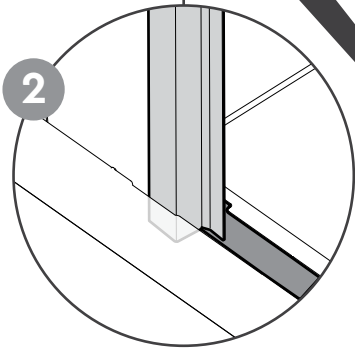
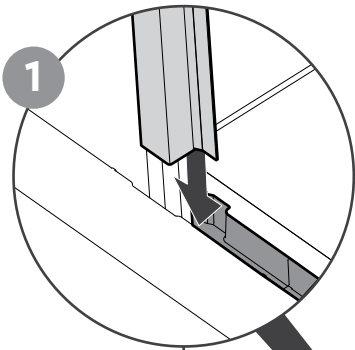
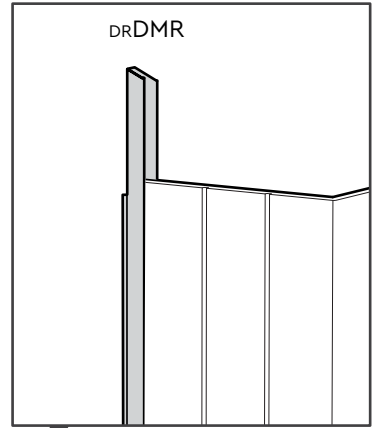
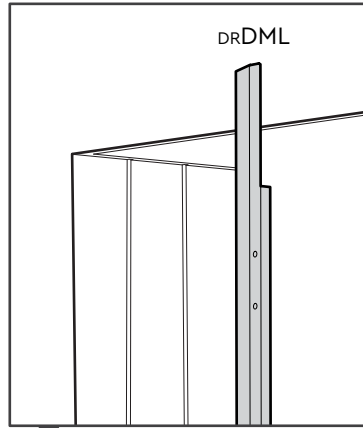
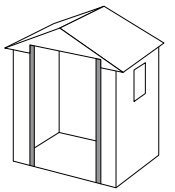

24

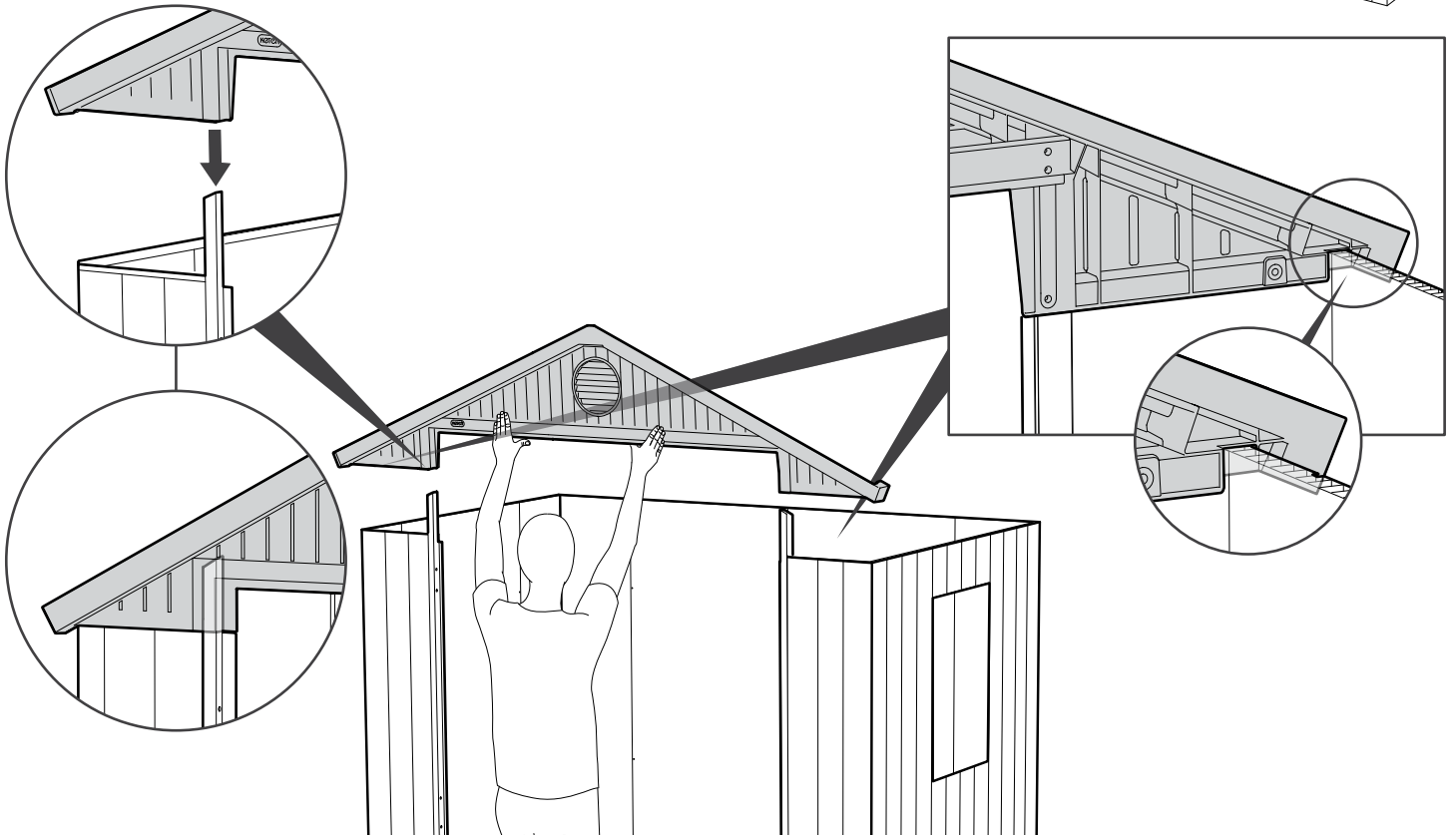
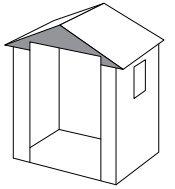

25

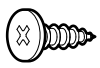

sc12t (x4)

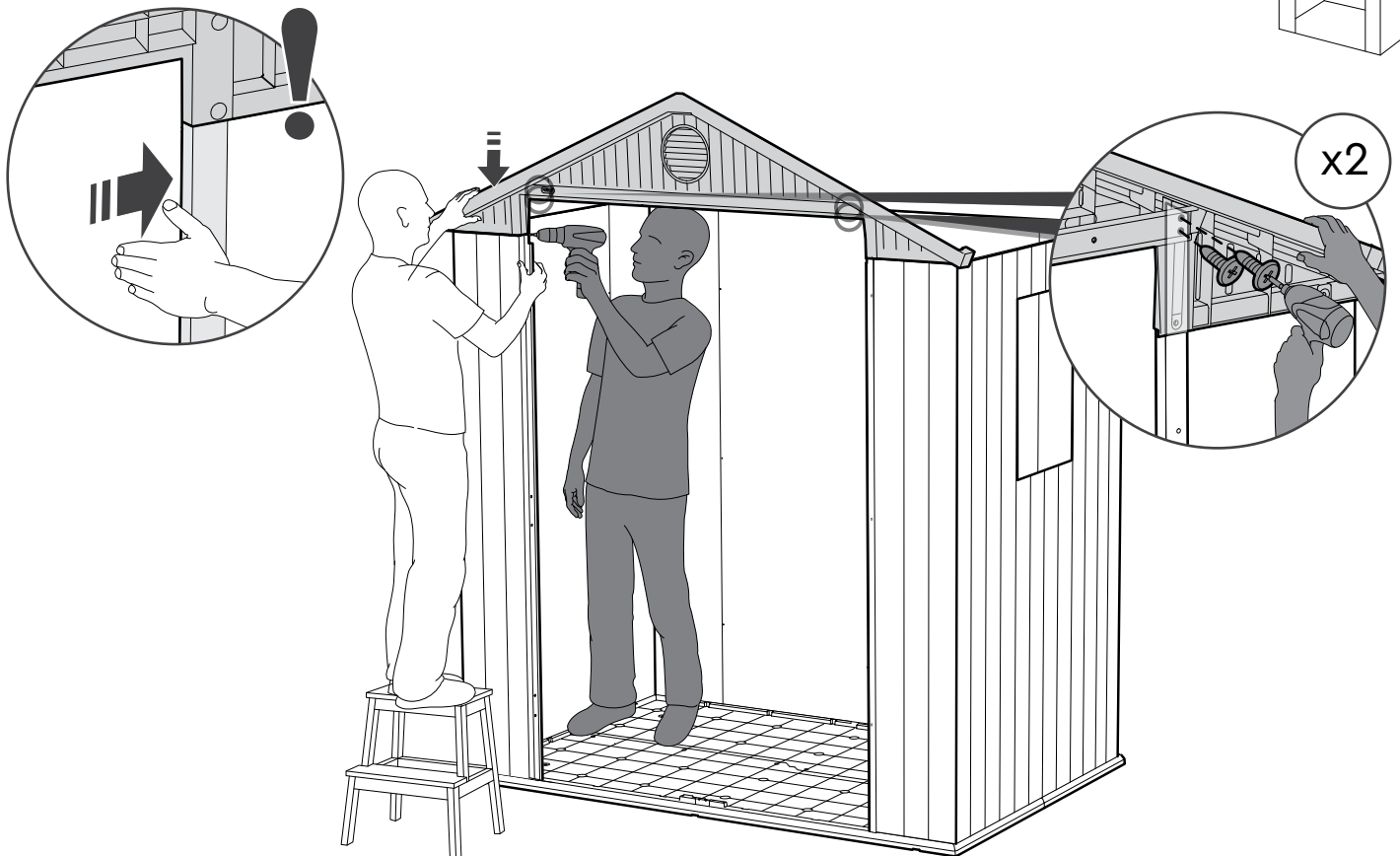
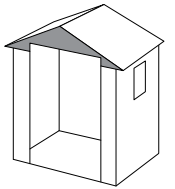

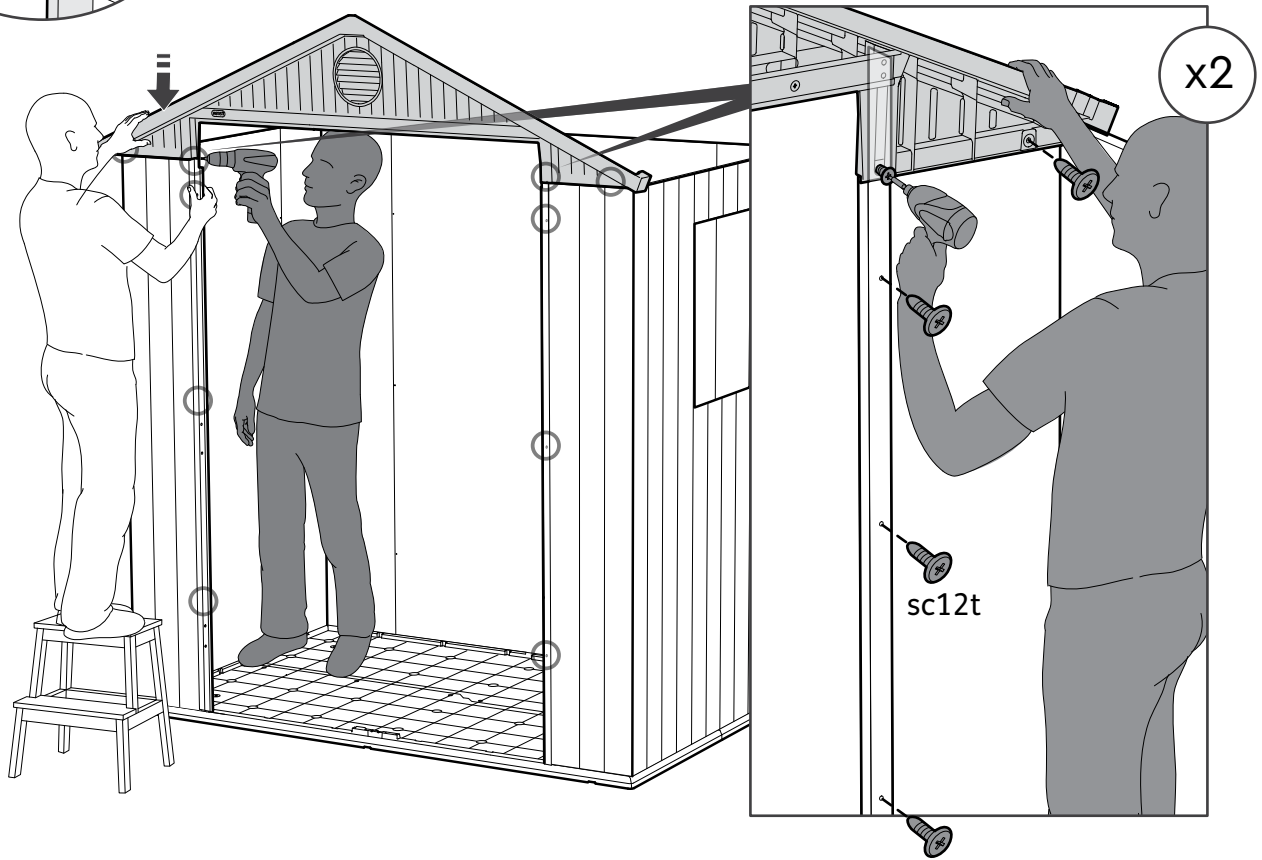
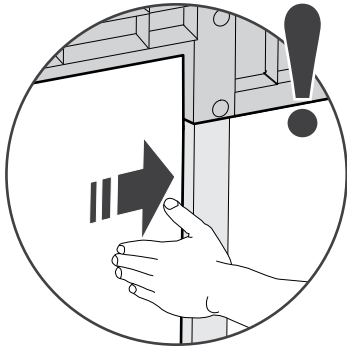
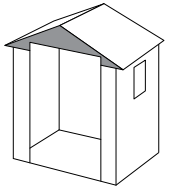
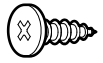

27

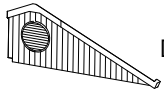

DRLRG (x1)

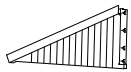

DRSRG (x1)



sc12t (x4)

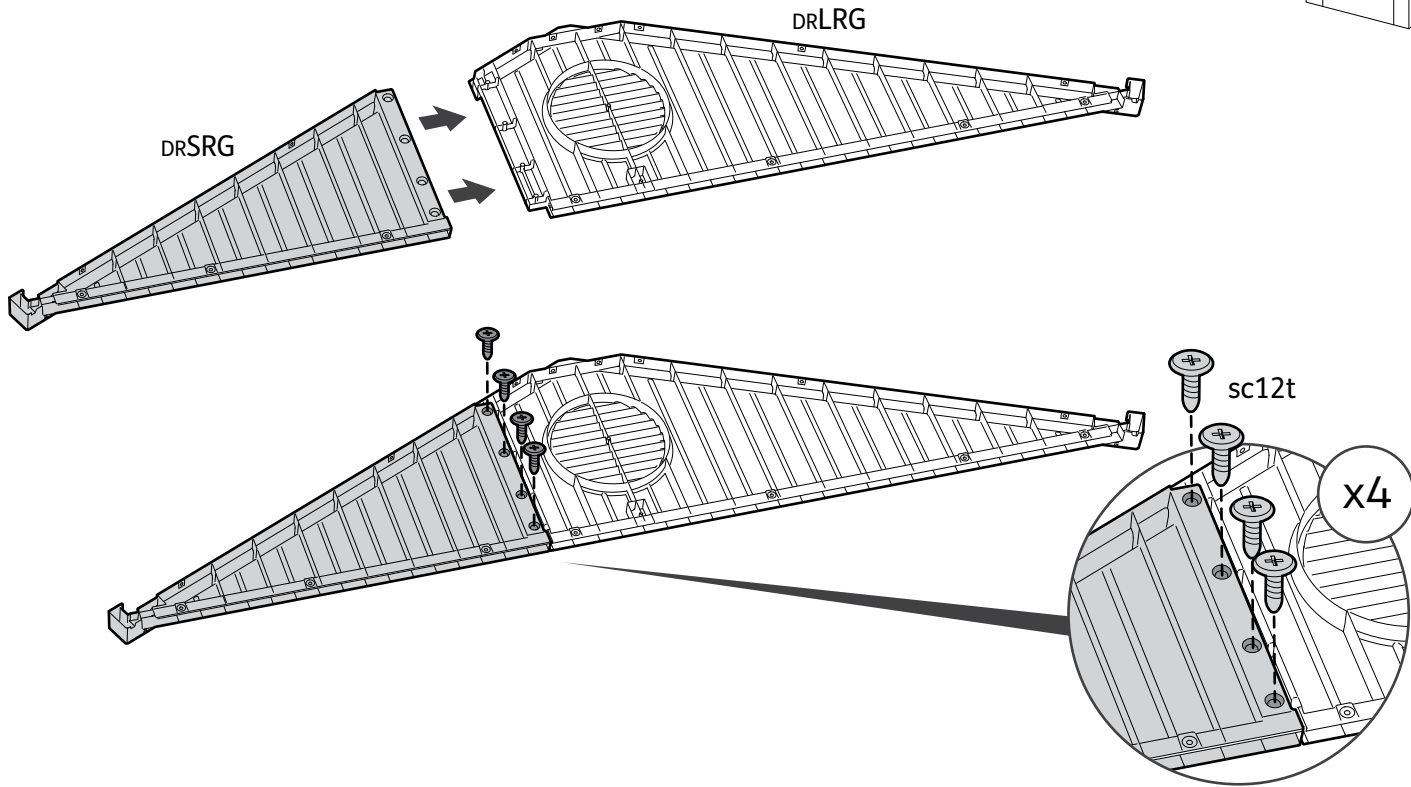
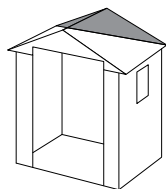

28

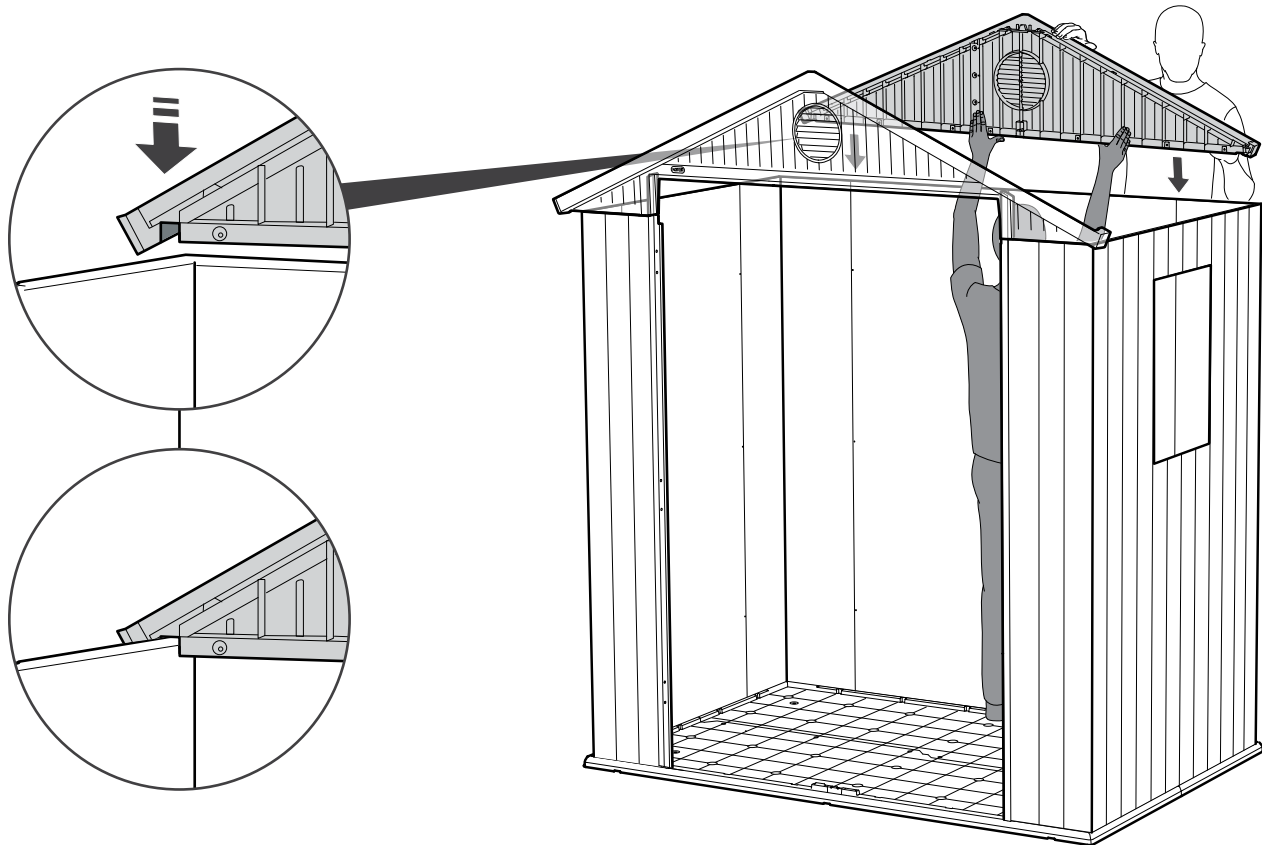
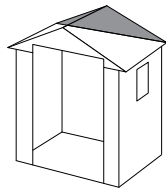
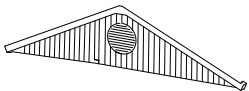

29



sc15 (x7)

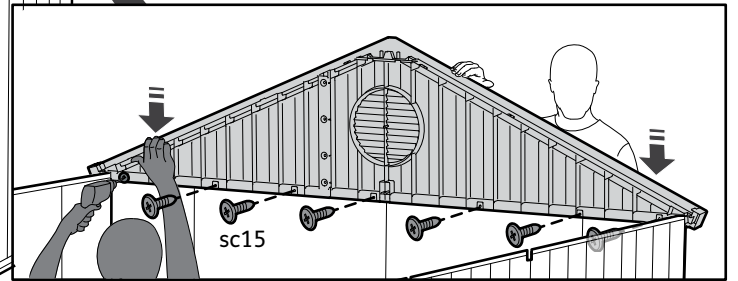
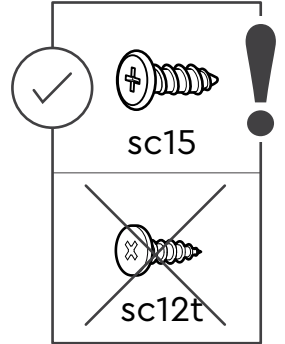
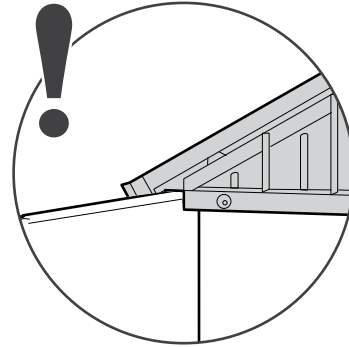
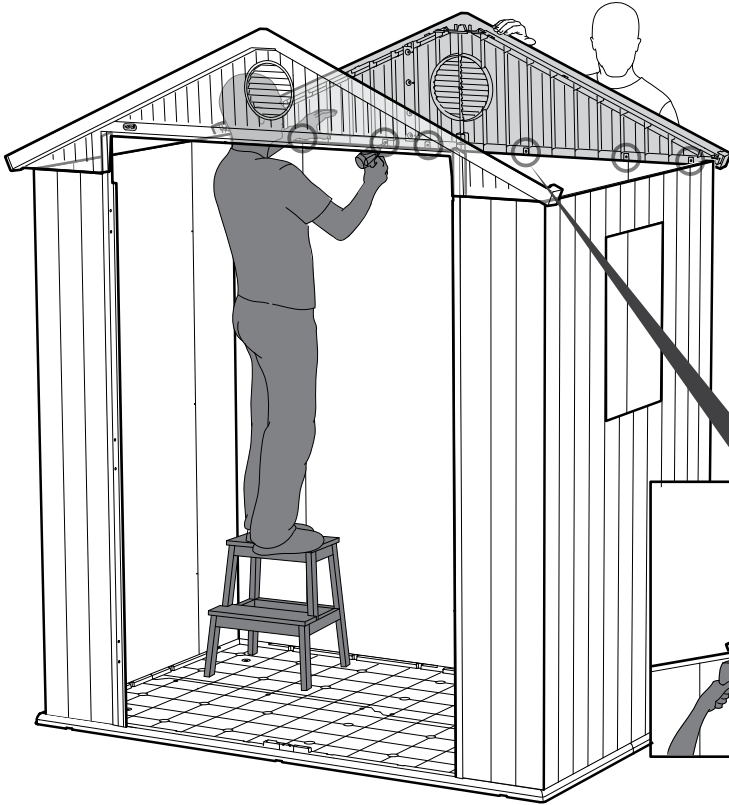
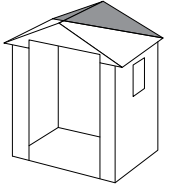

30

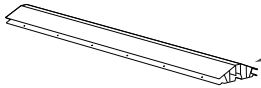

DRCB (x1)



sc12t (x4)

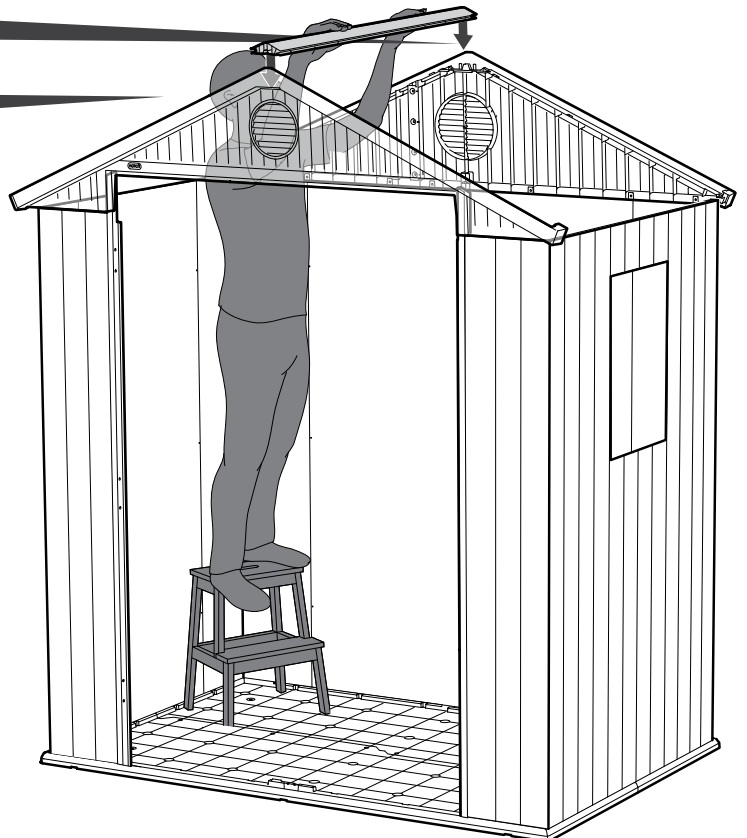
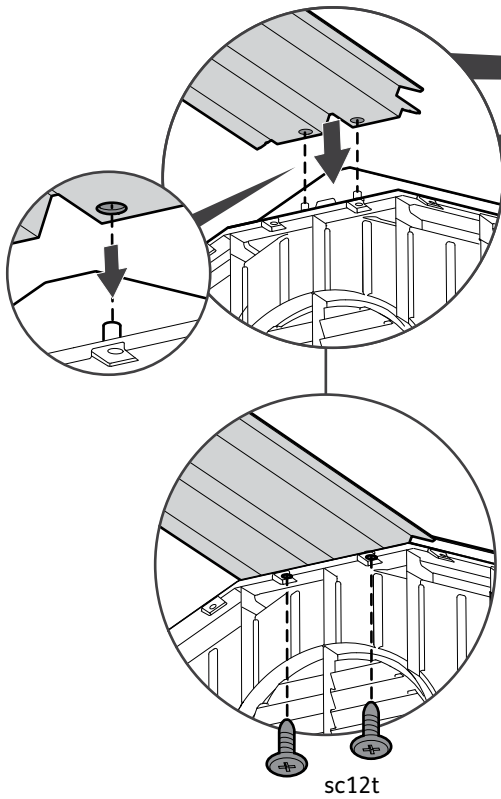
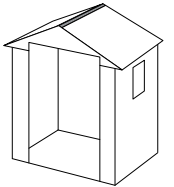

31



DRPM (x2)

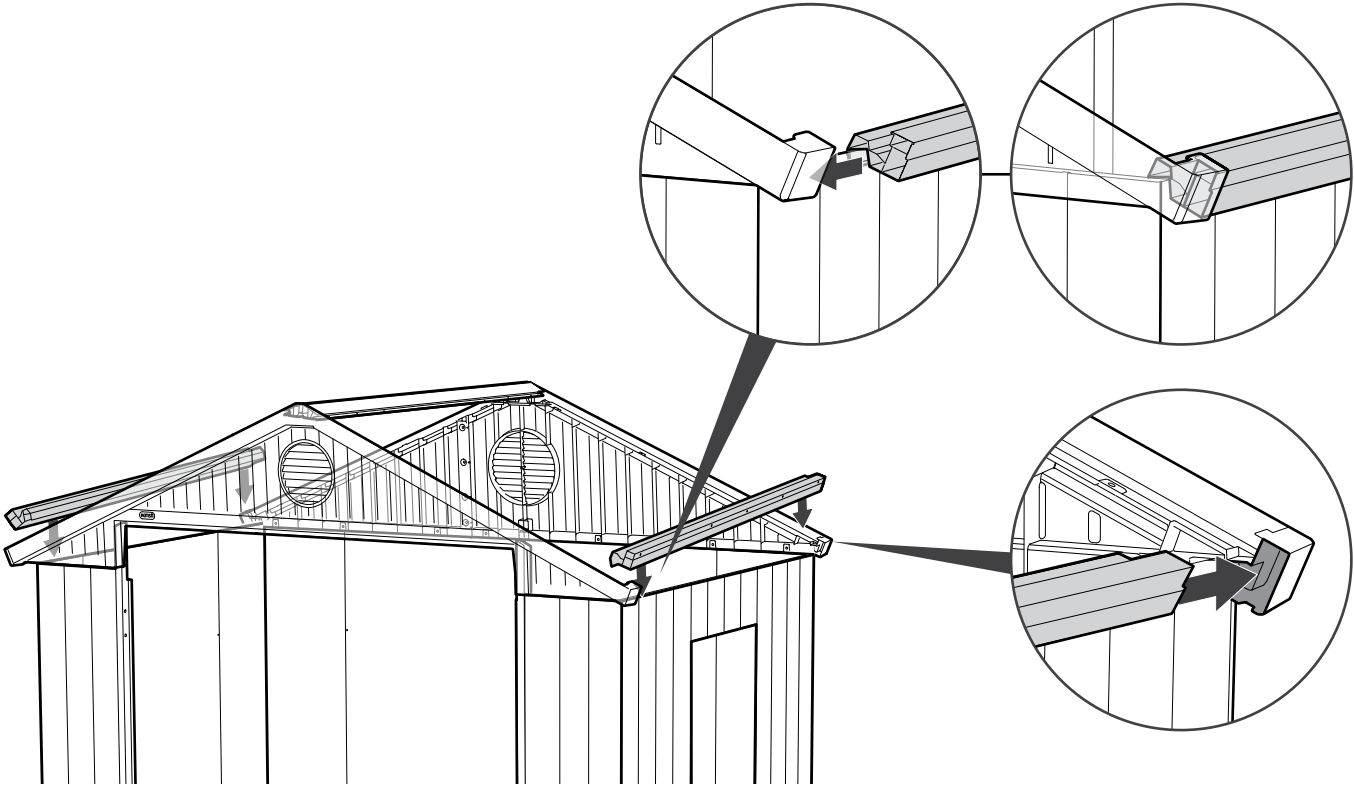
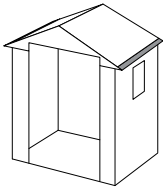

32

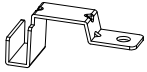

DRCC (x4)



sc12t (x4)

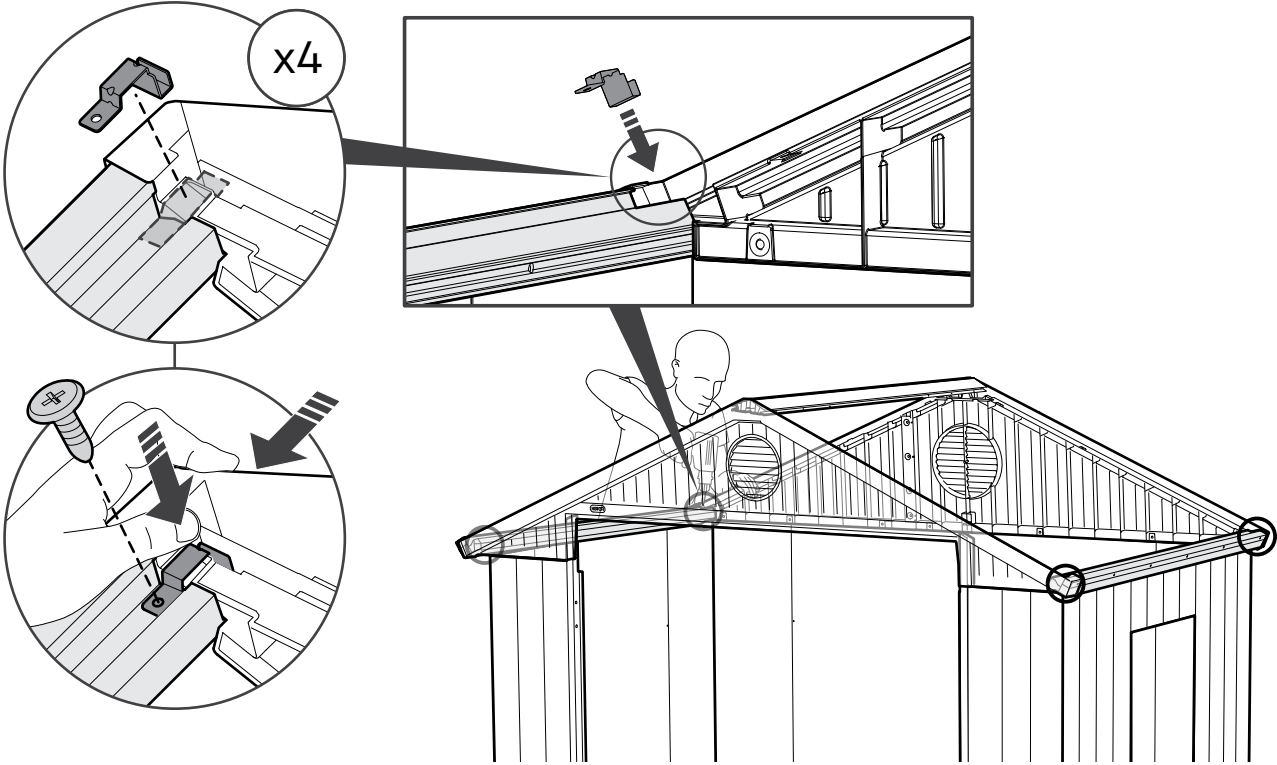
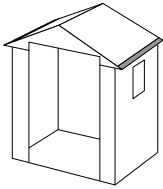

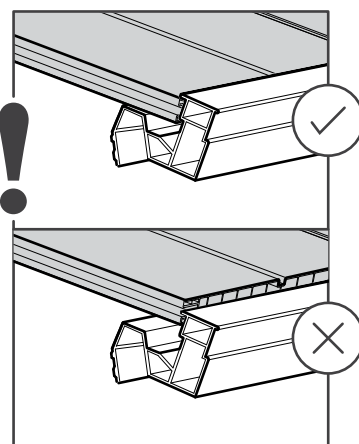
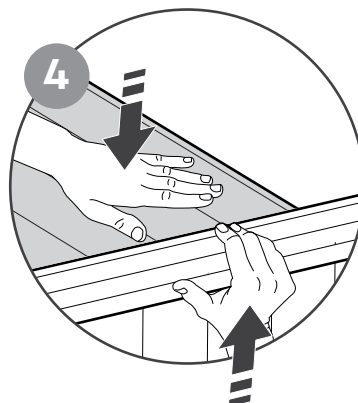
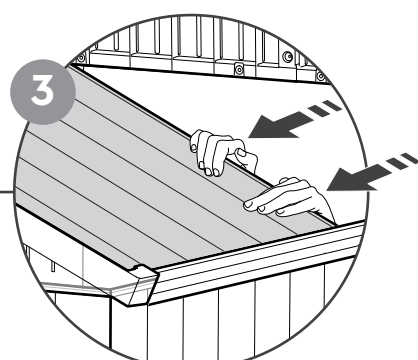
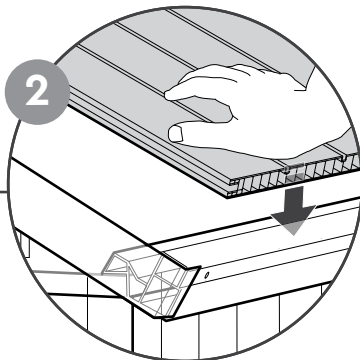
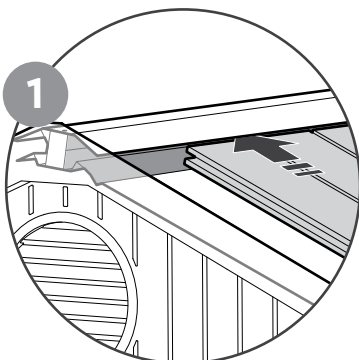
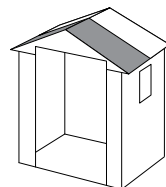

34



sc12t (x2)

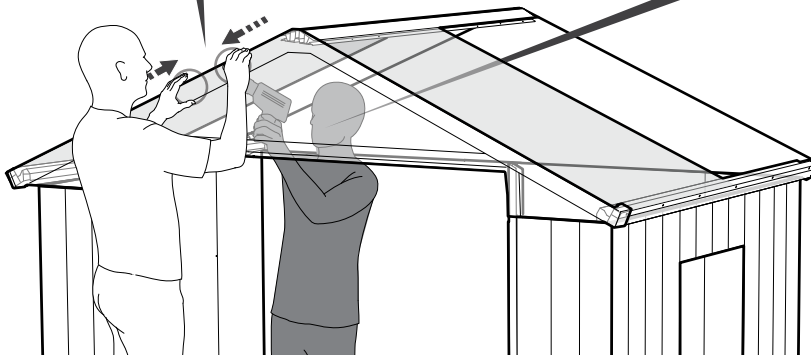
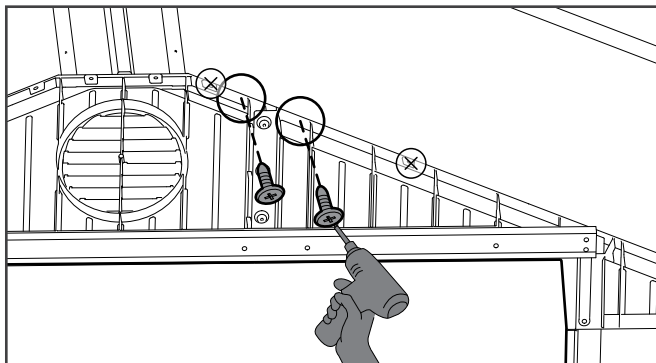
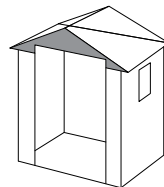

35



sc12t (x6)

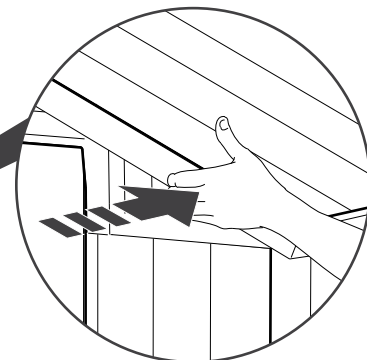
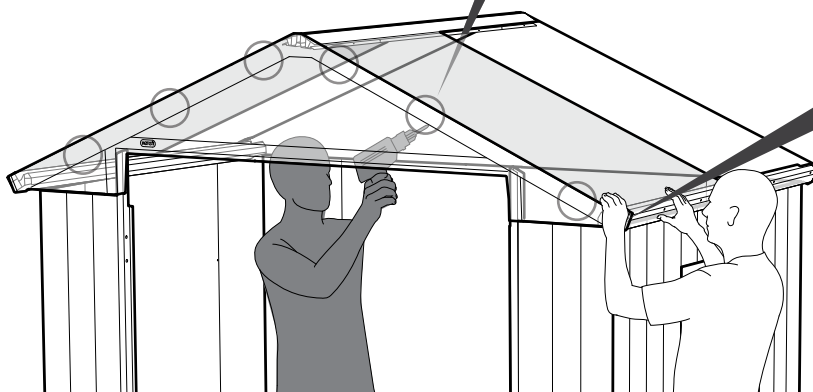
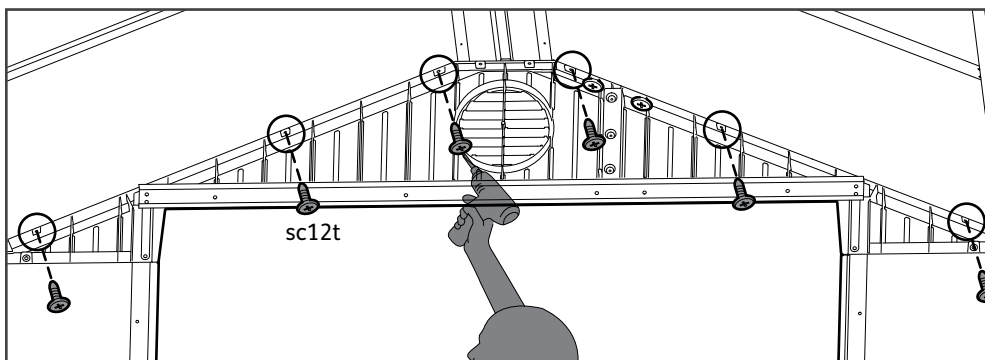
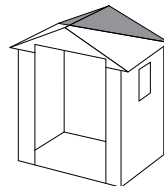



DRMDT (x2)

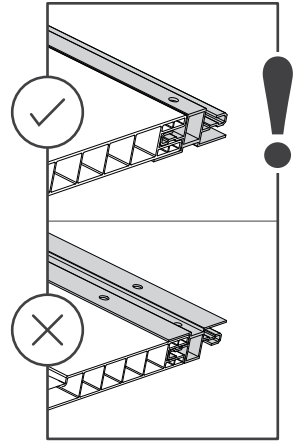
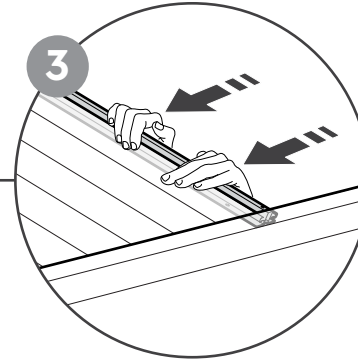
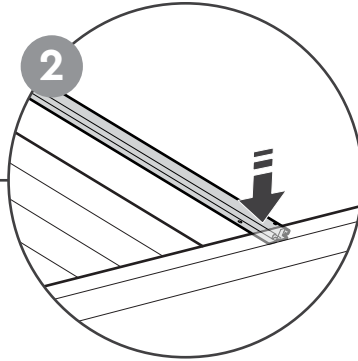
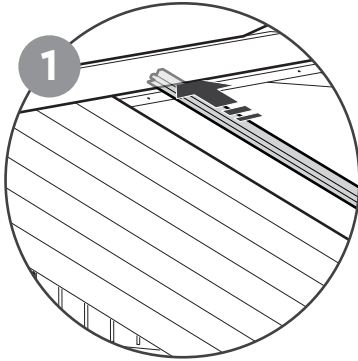
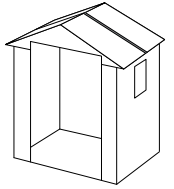

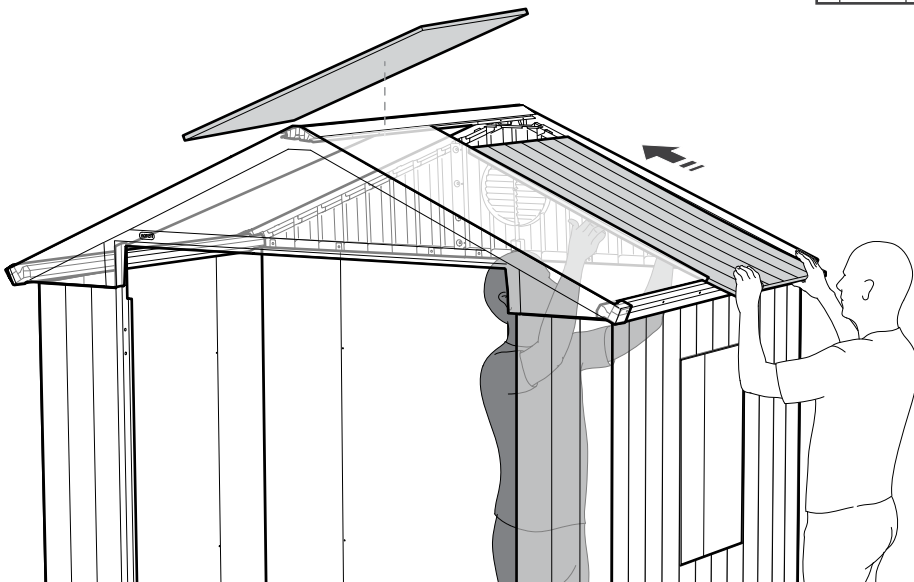
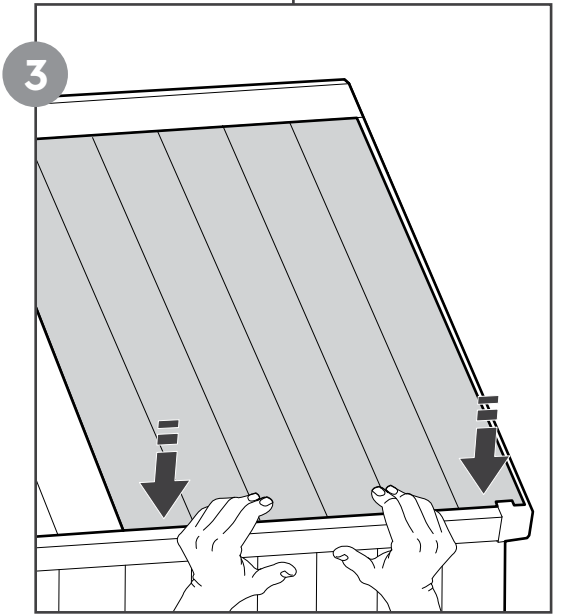
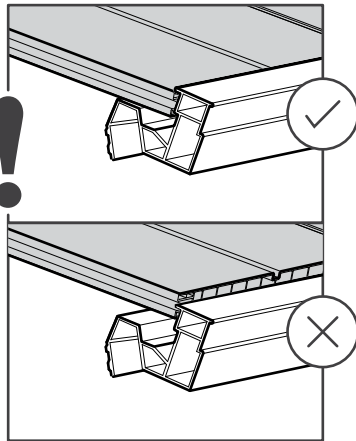
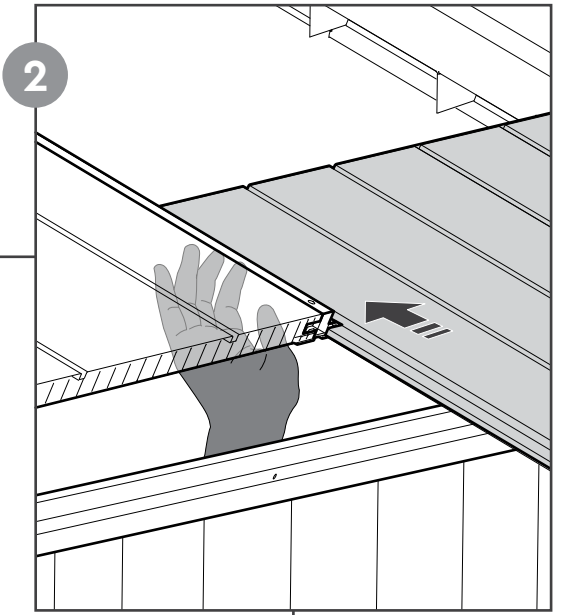
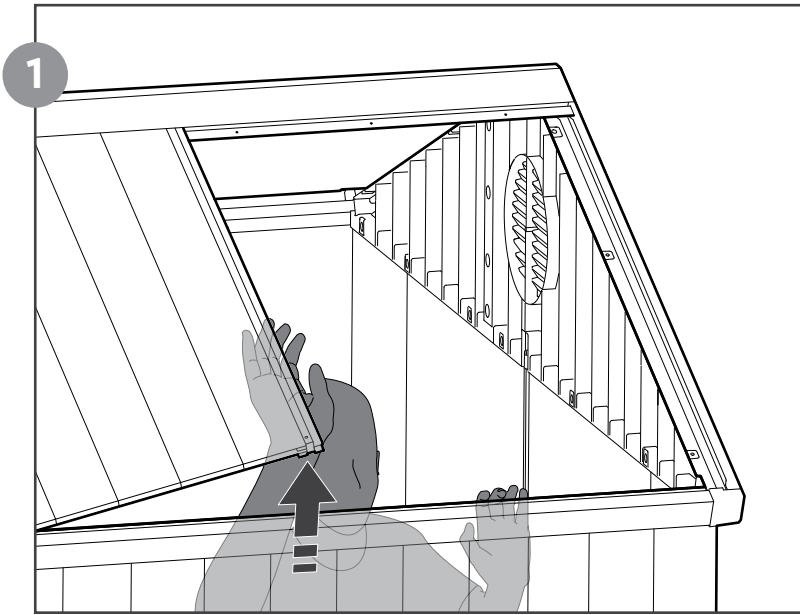
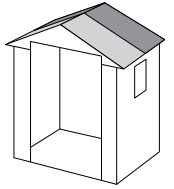

38



sc12t (x2)

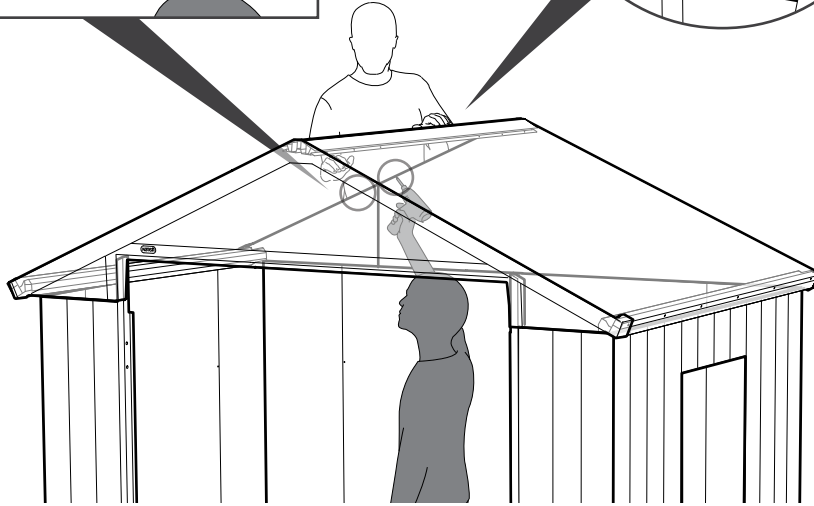
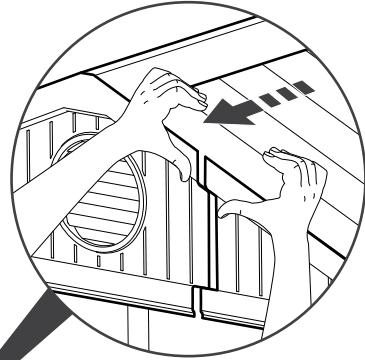
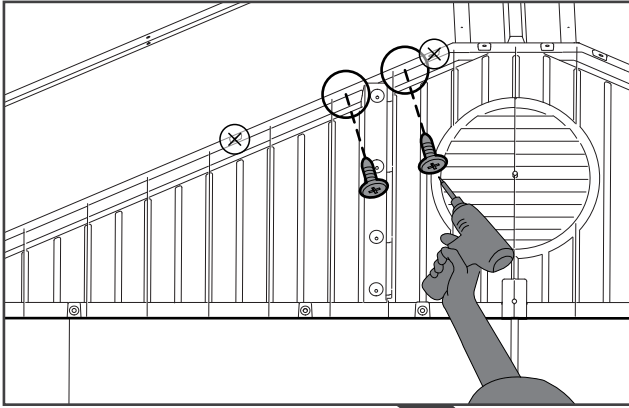
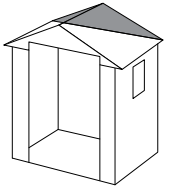

39



sc12t (x6)

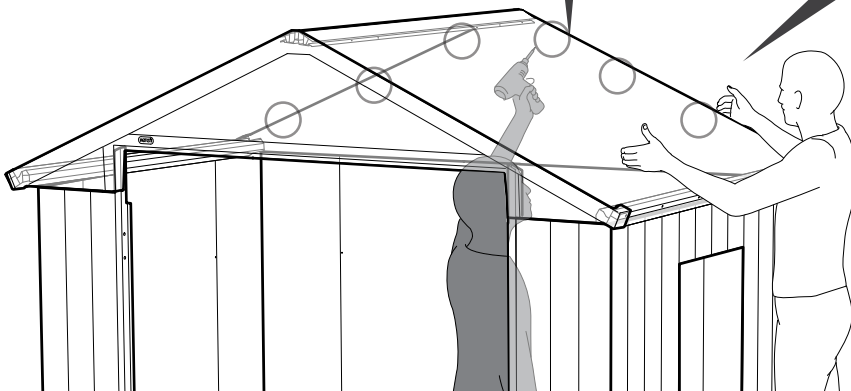
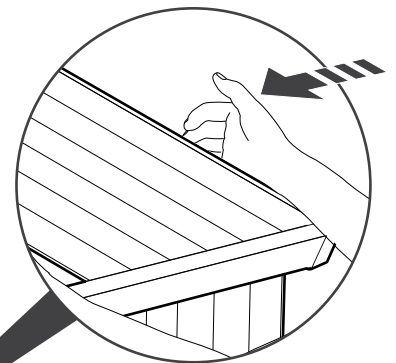
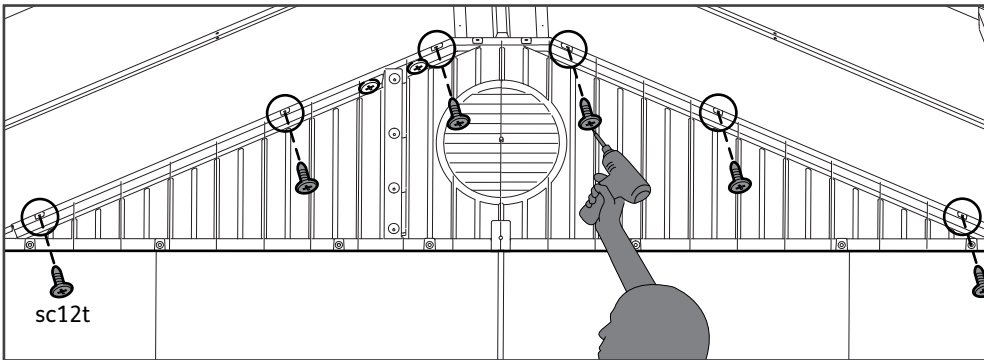
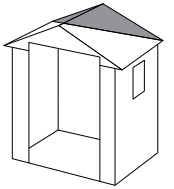

40



sc36 (x2)

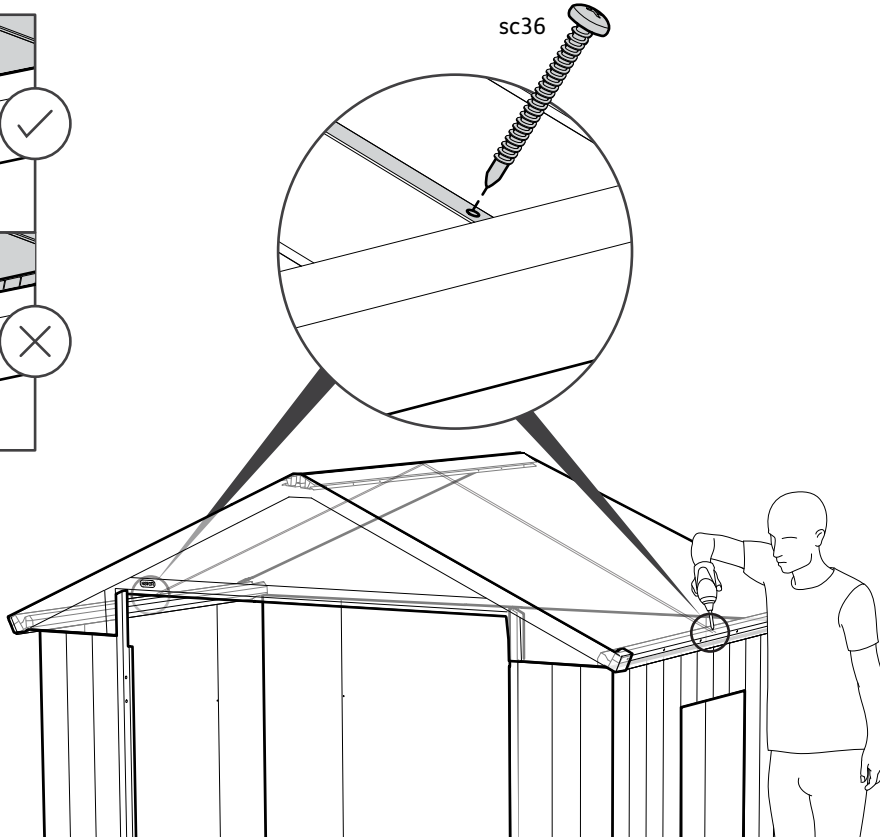
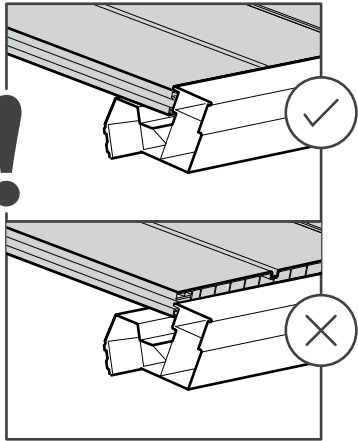
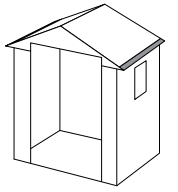

41



sc12t (x8)

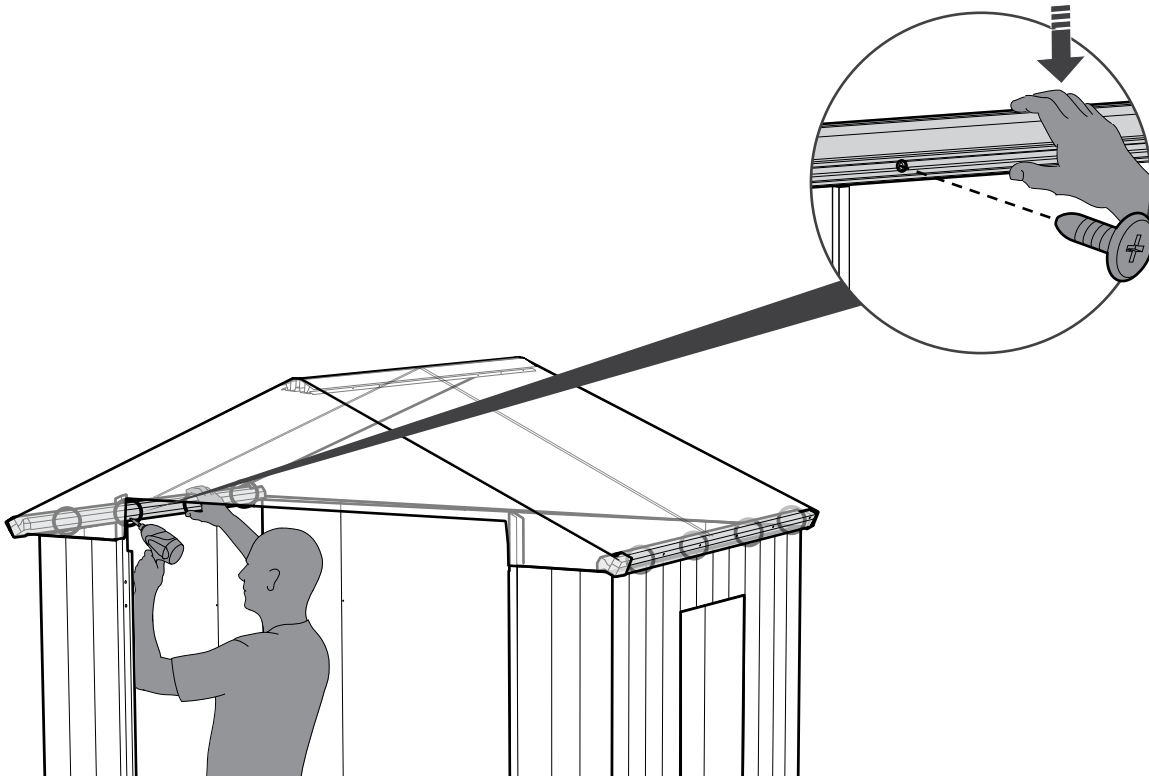
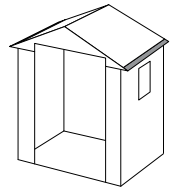

42



sc12t (x12)

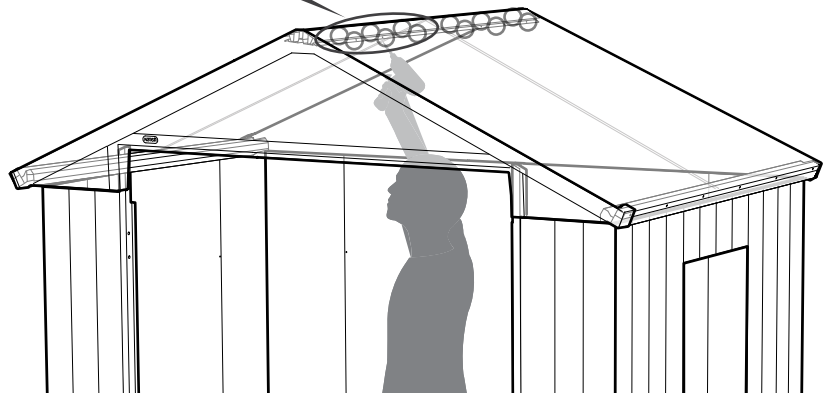
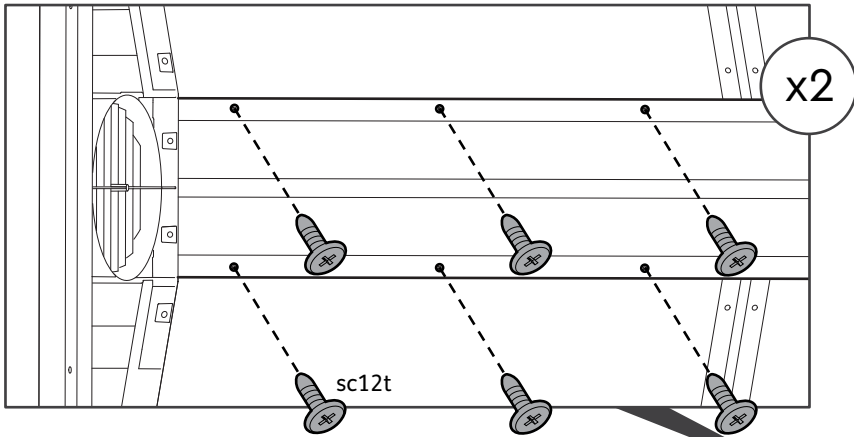
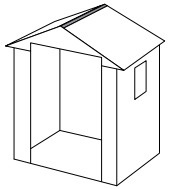

43



sc7t (x12)

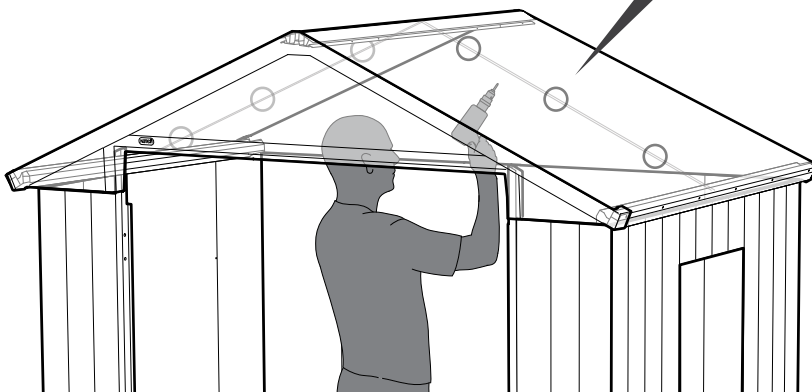
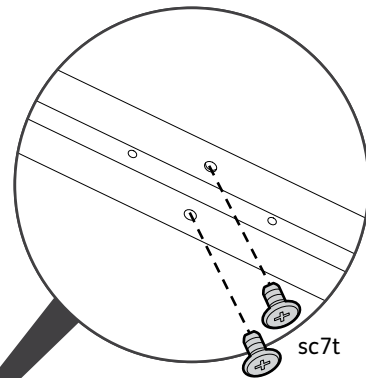
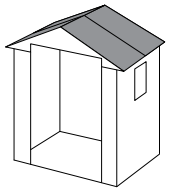

A vertical rectangular box containing two sections. The top section features a large exclamation mark on the left, a screw icon with a plus sign in the center, and a checkmark in a circle on the right. Below these is the text "sc7t". The bottom section features a screw icon with an 'X' in the center, crossed out by a large 'X', and the text "sc12t" below it.

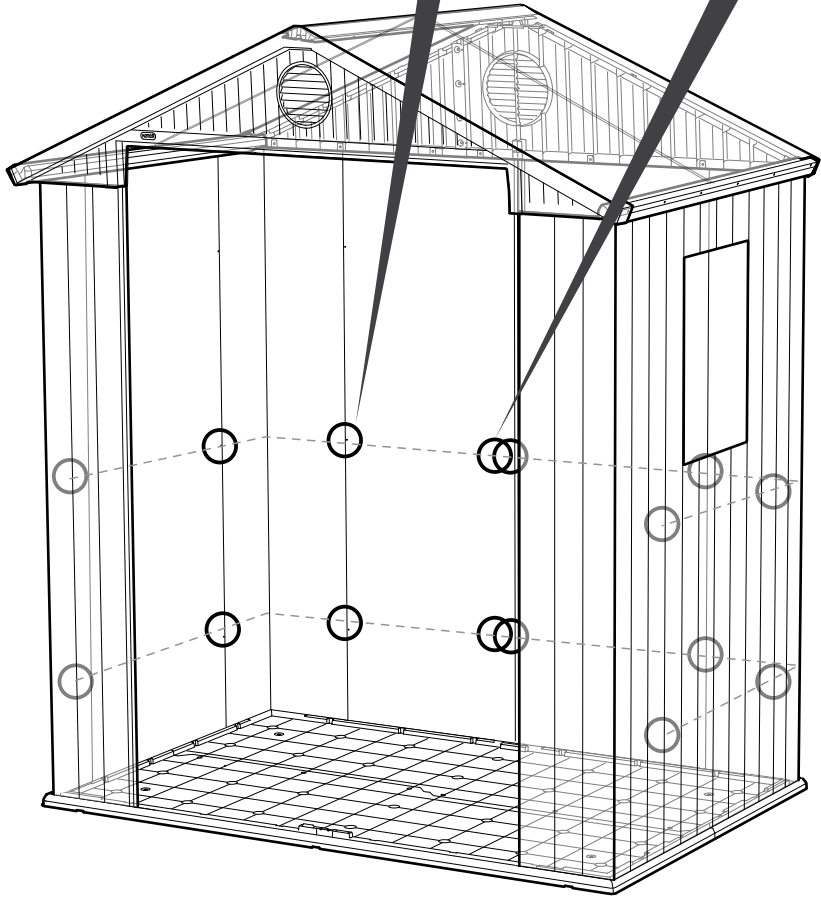
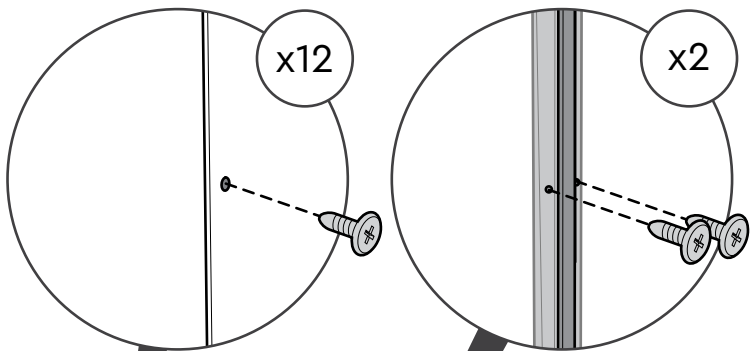
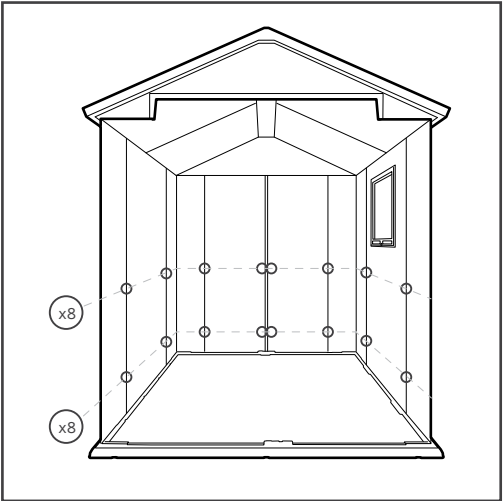
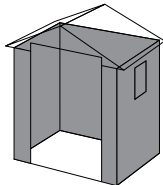

45



DRWMP (x1)



sc12t (x1)

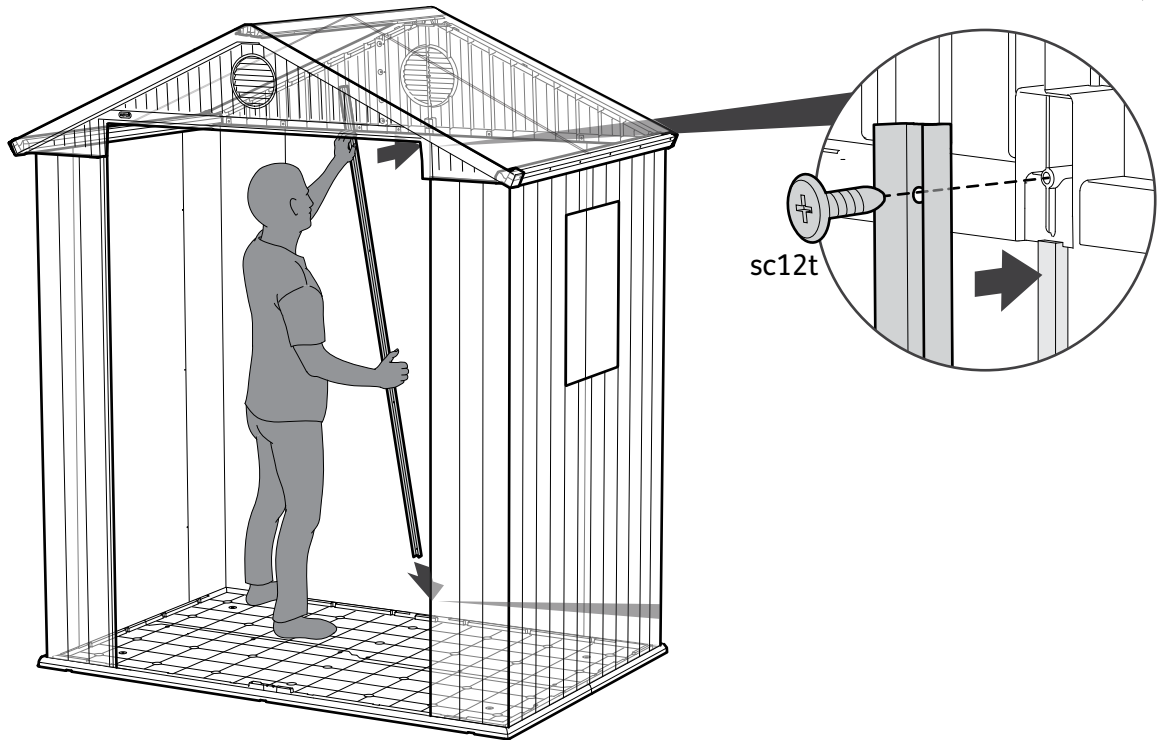
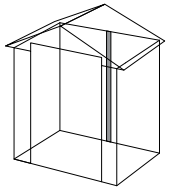

46



sc12t (x3)

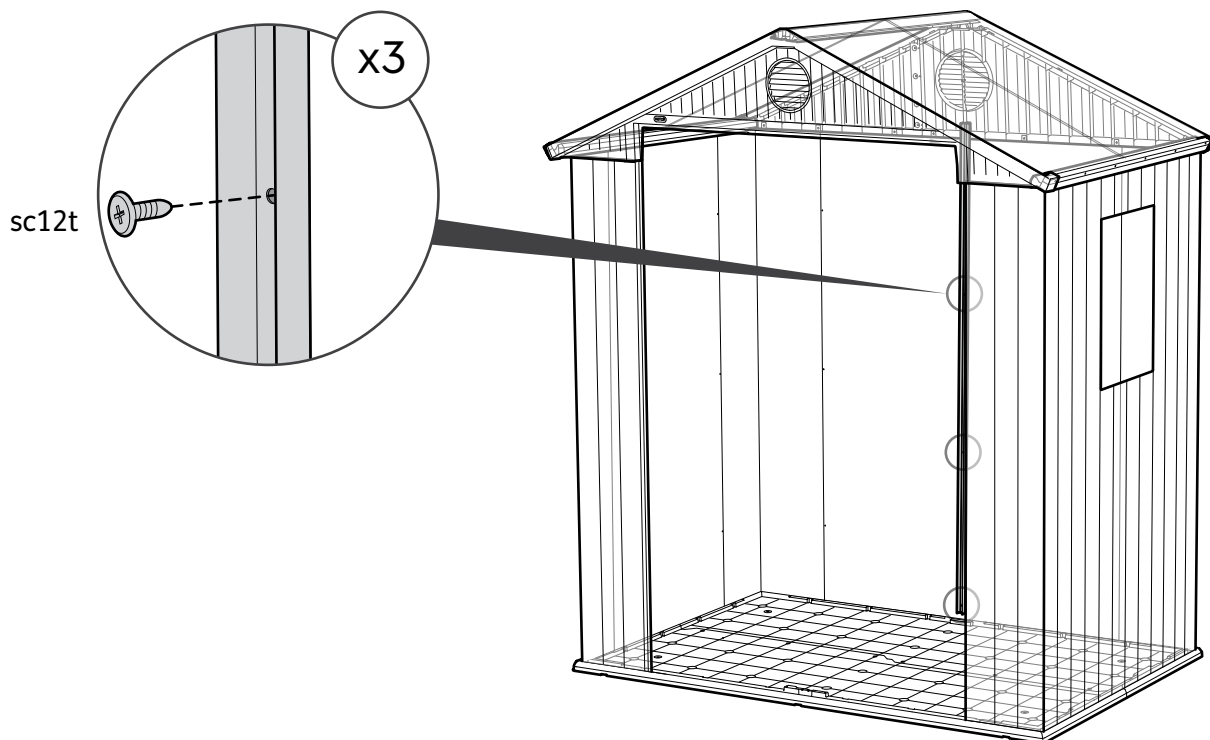
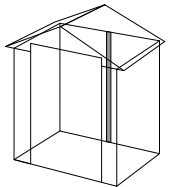

47



d6BP (x1)

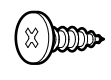

sc12t (x4)

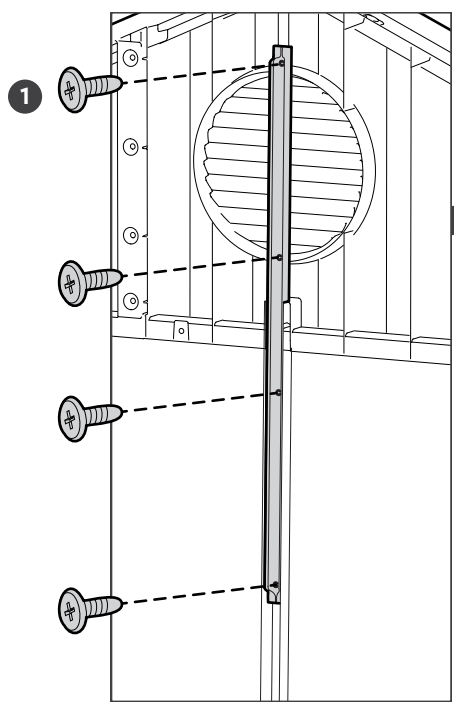
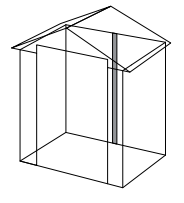

48



sc36 (x8)

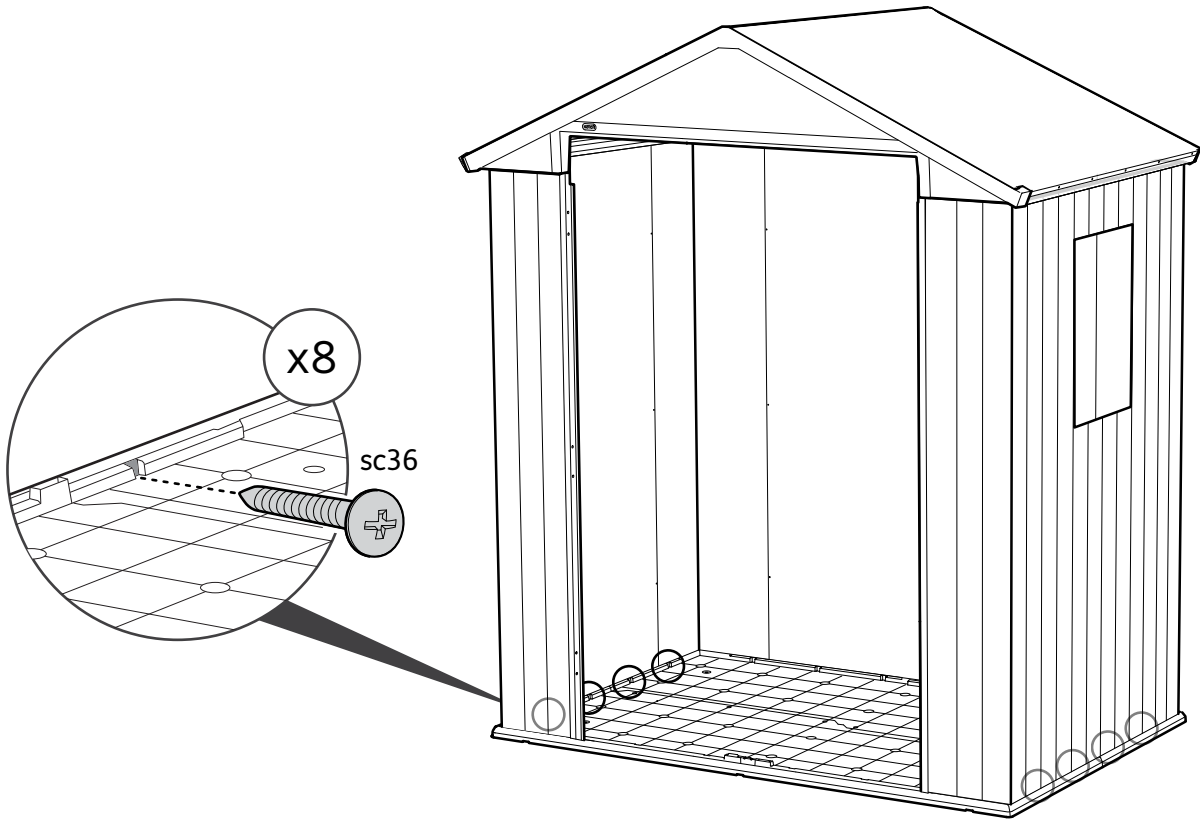
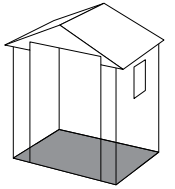

49



sc36 (x8)

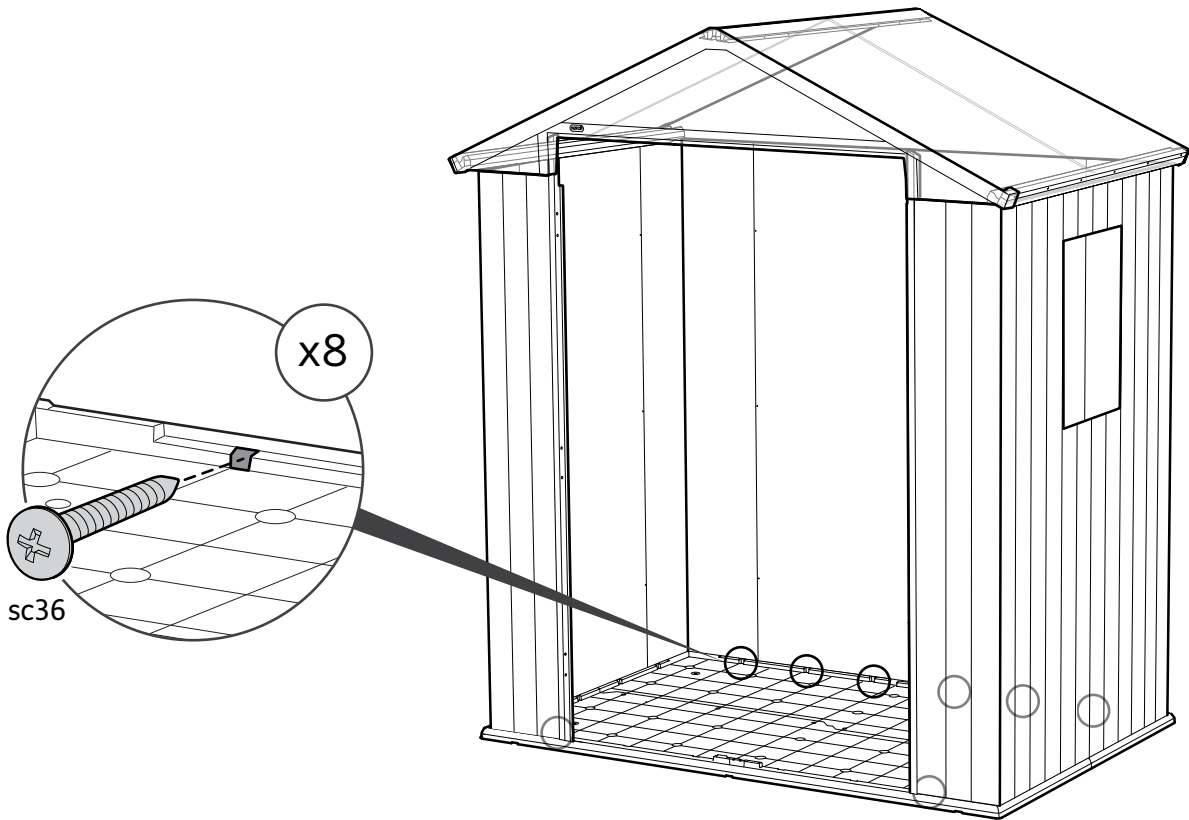
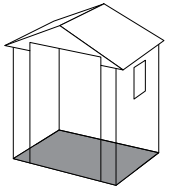

50



DRPD (x4)

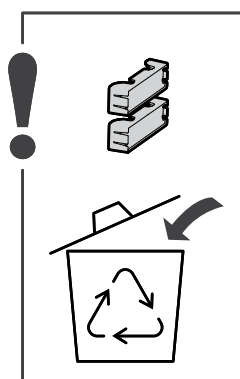
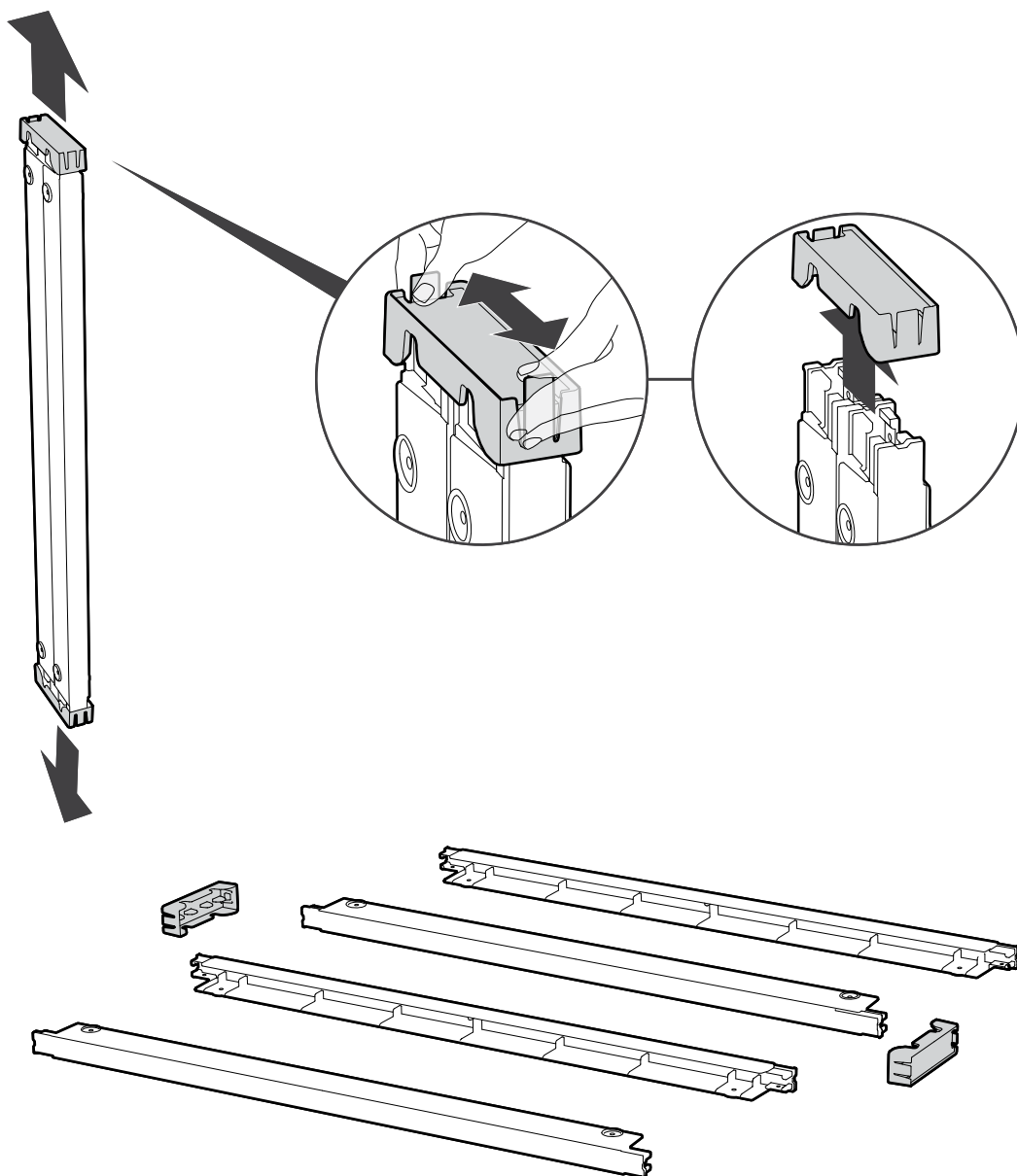
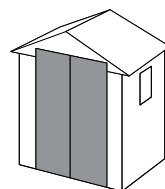

51

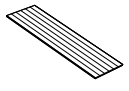

DR6D (x2)



DRPD (x4)

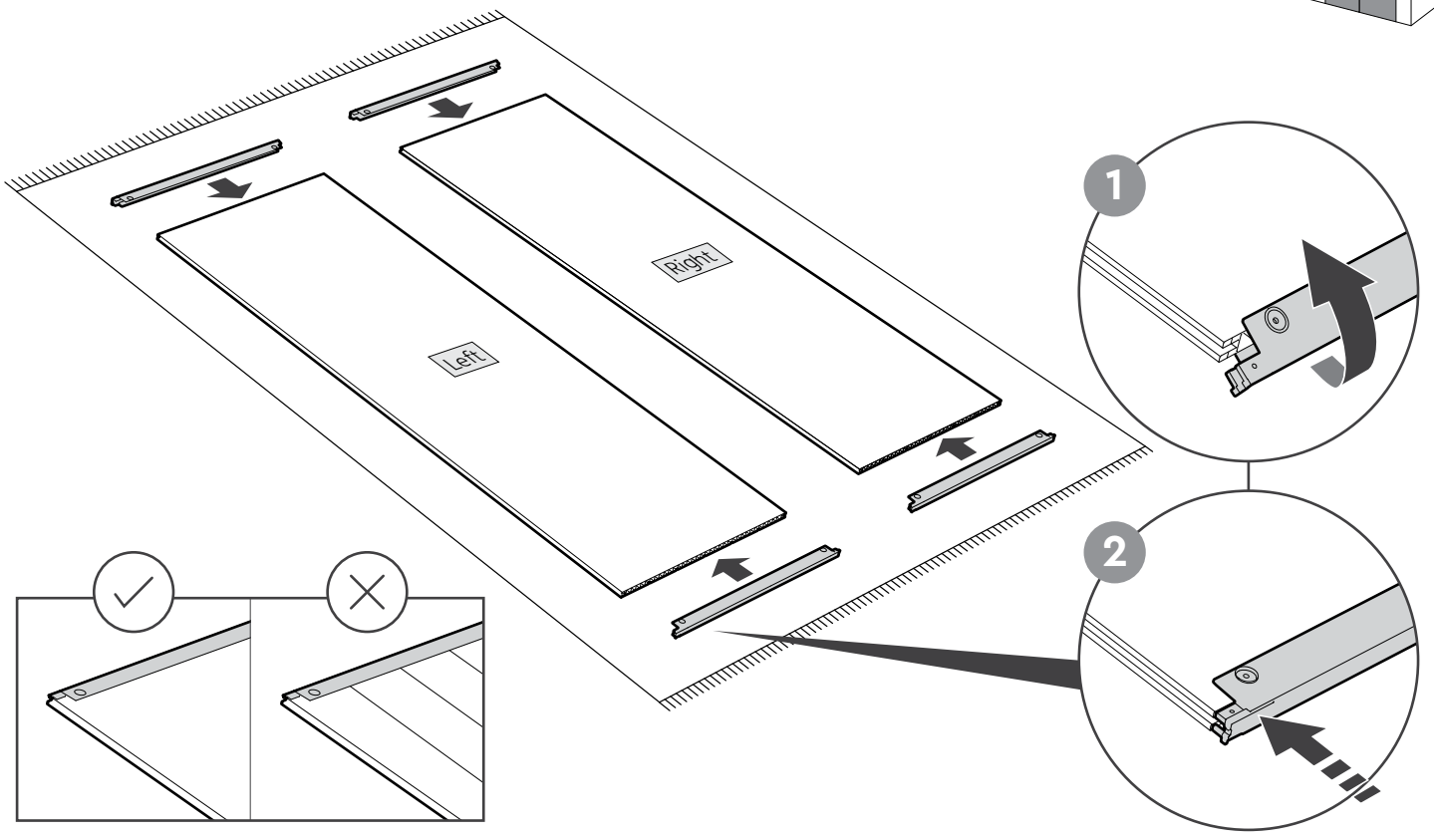
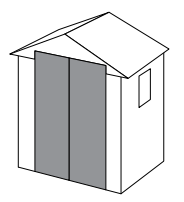

52

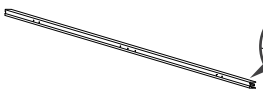

DRMA (x3)



DRMW (x1)

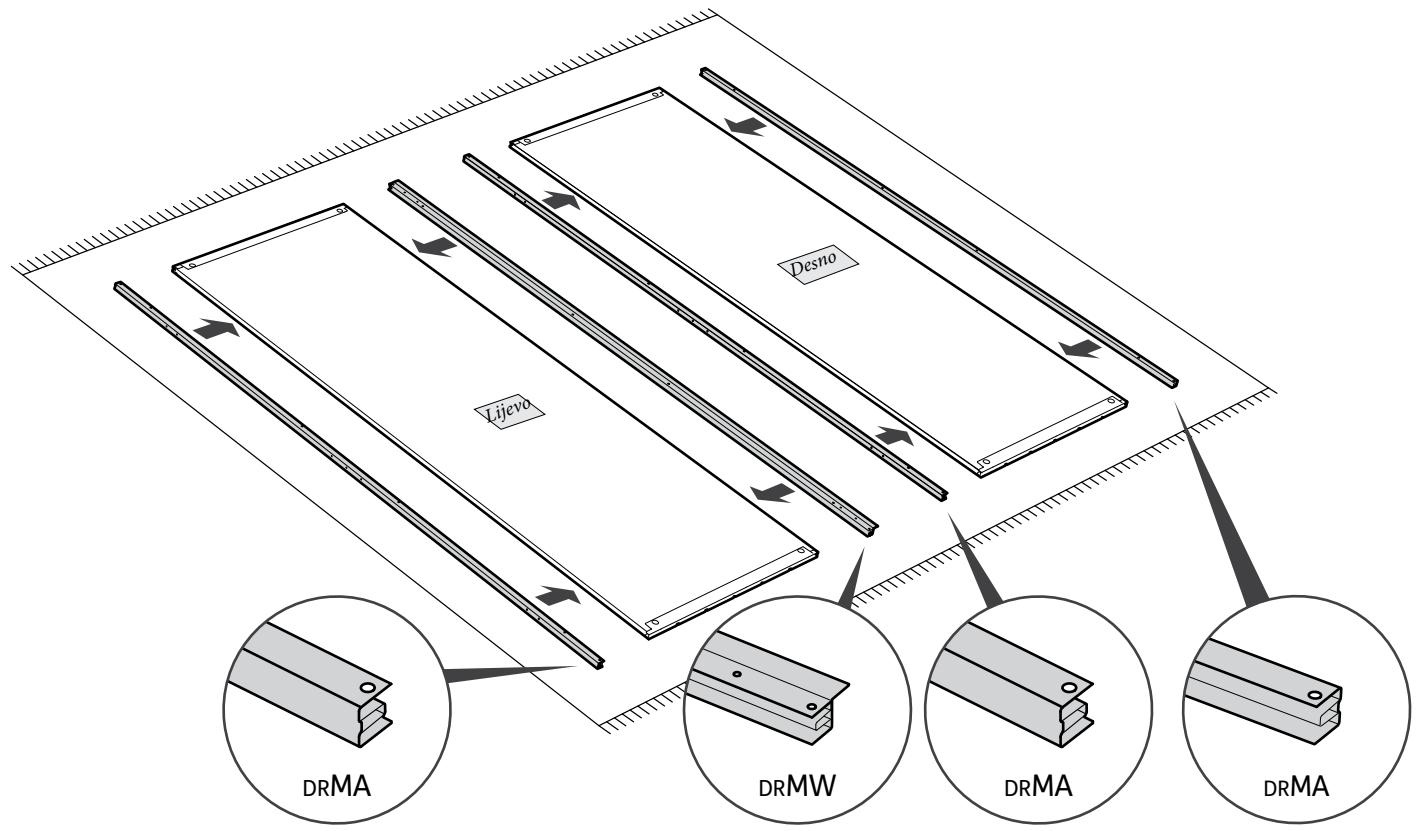
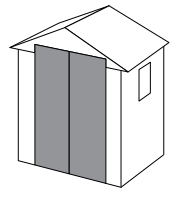

53

sc12t (x8)

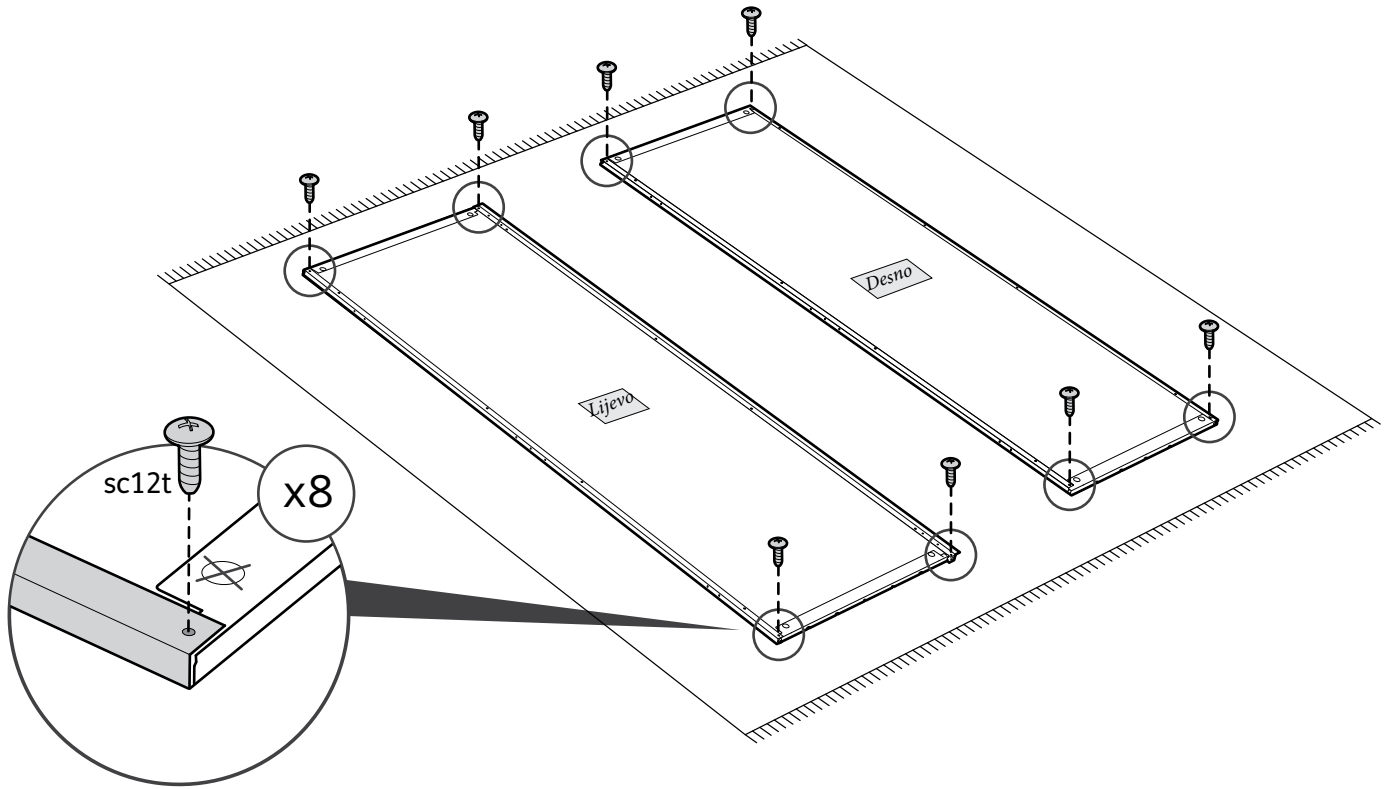
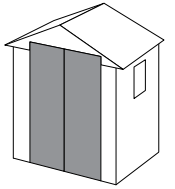

54

sc12t (x24)

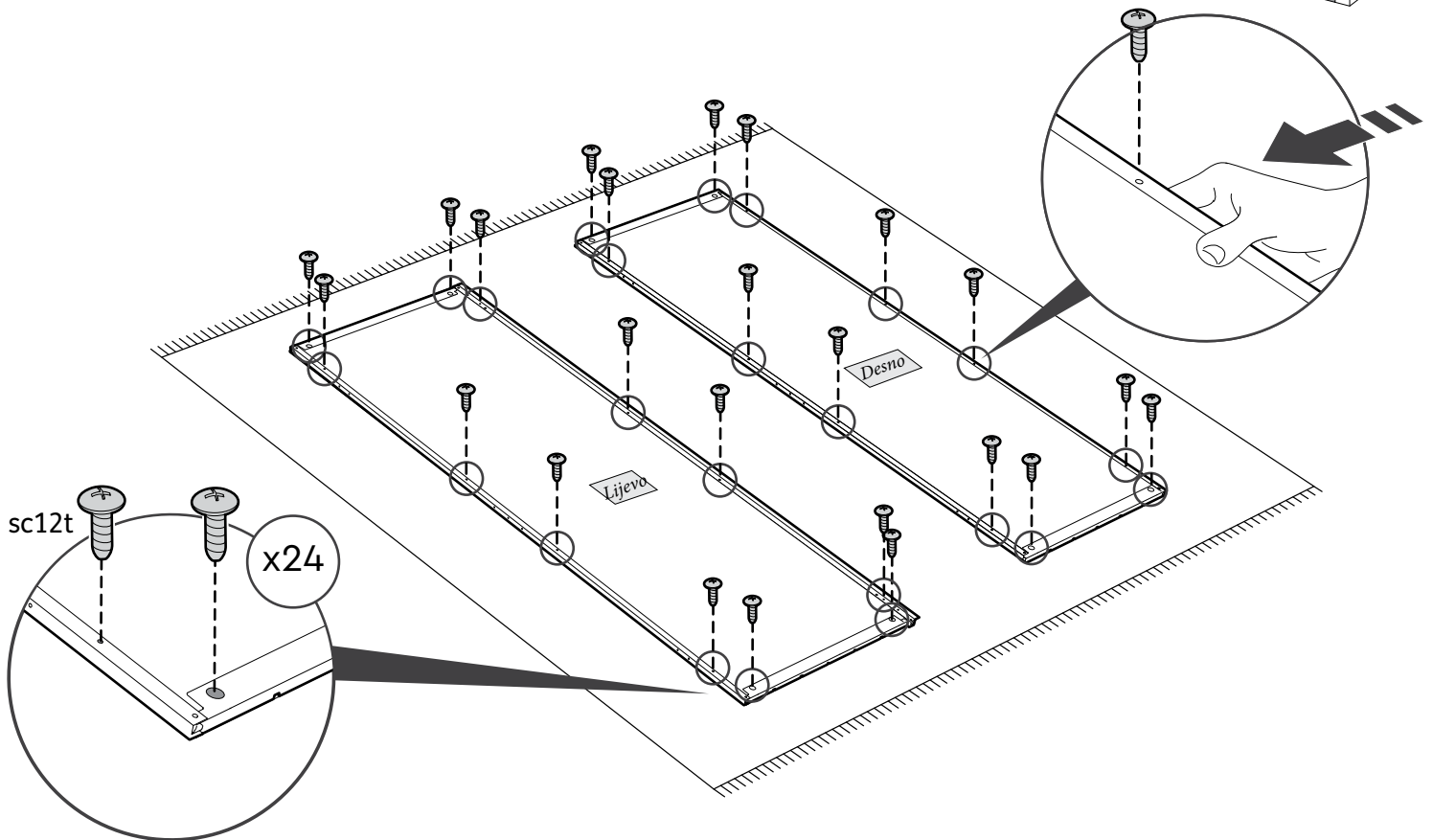
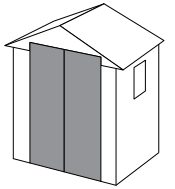

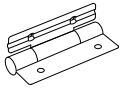
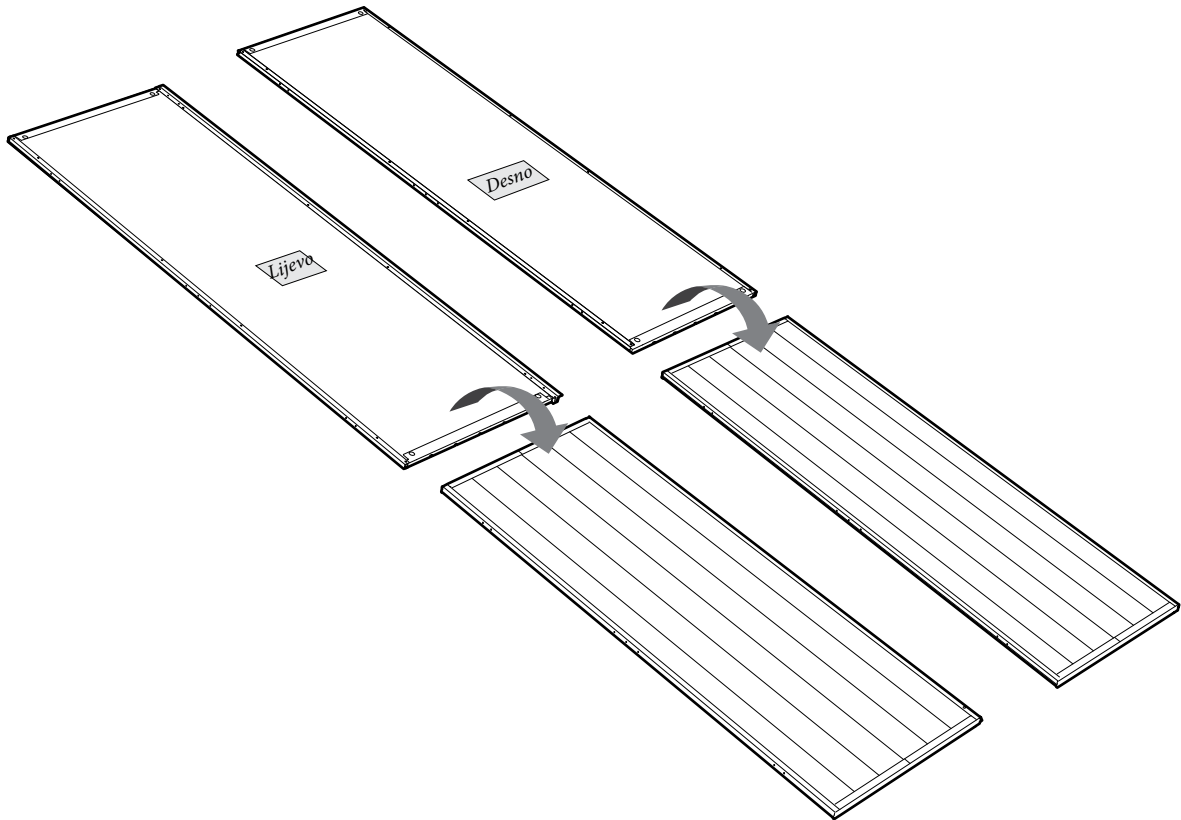
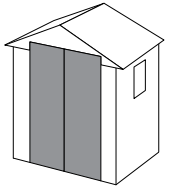

DRHG (x4)

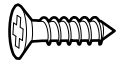

sw15d (x8)

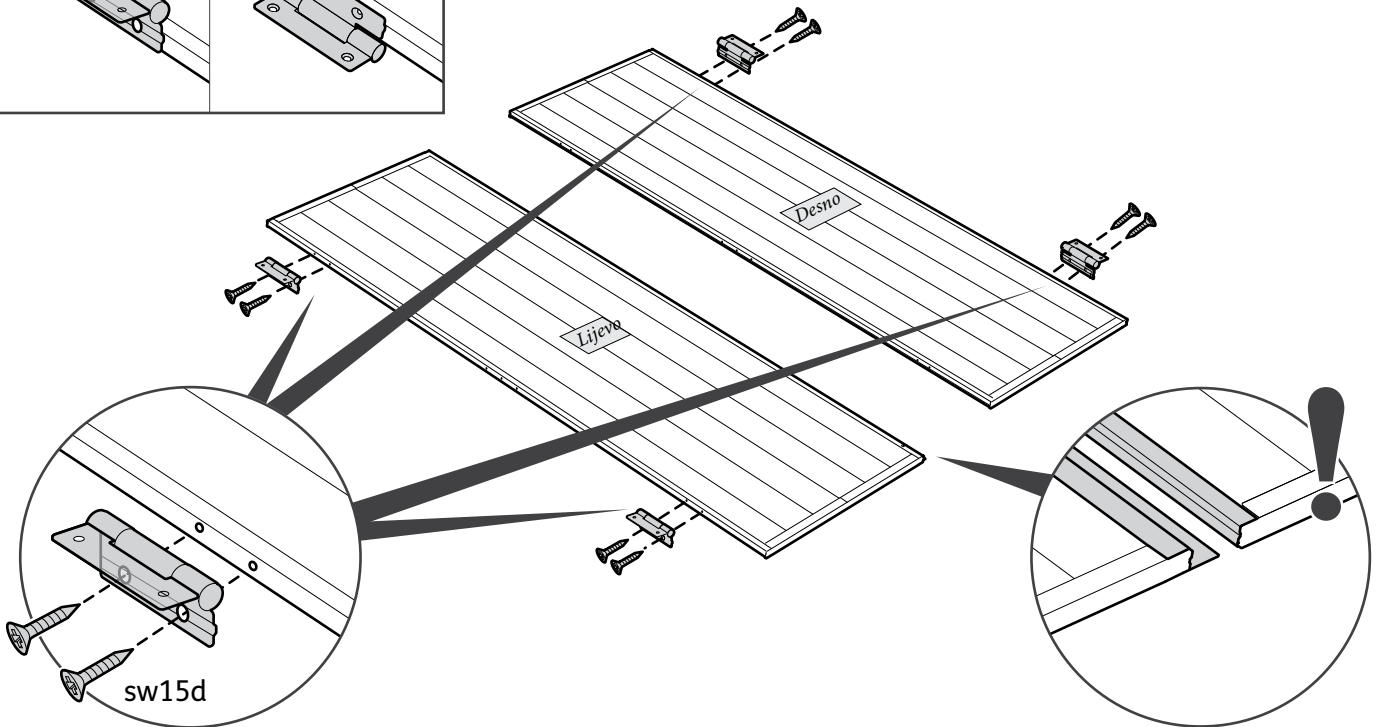
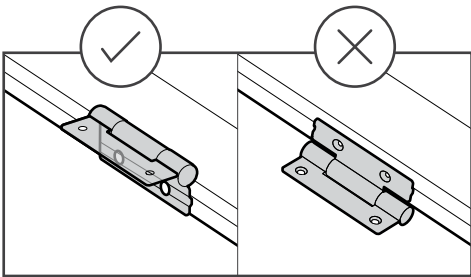
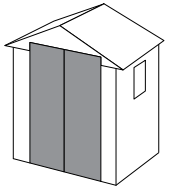

57

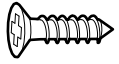

sw15d (x8)

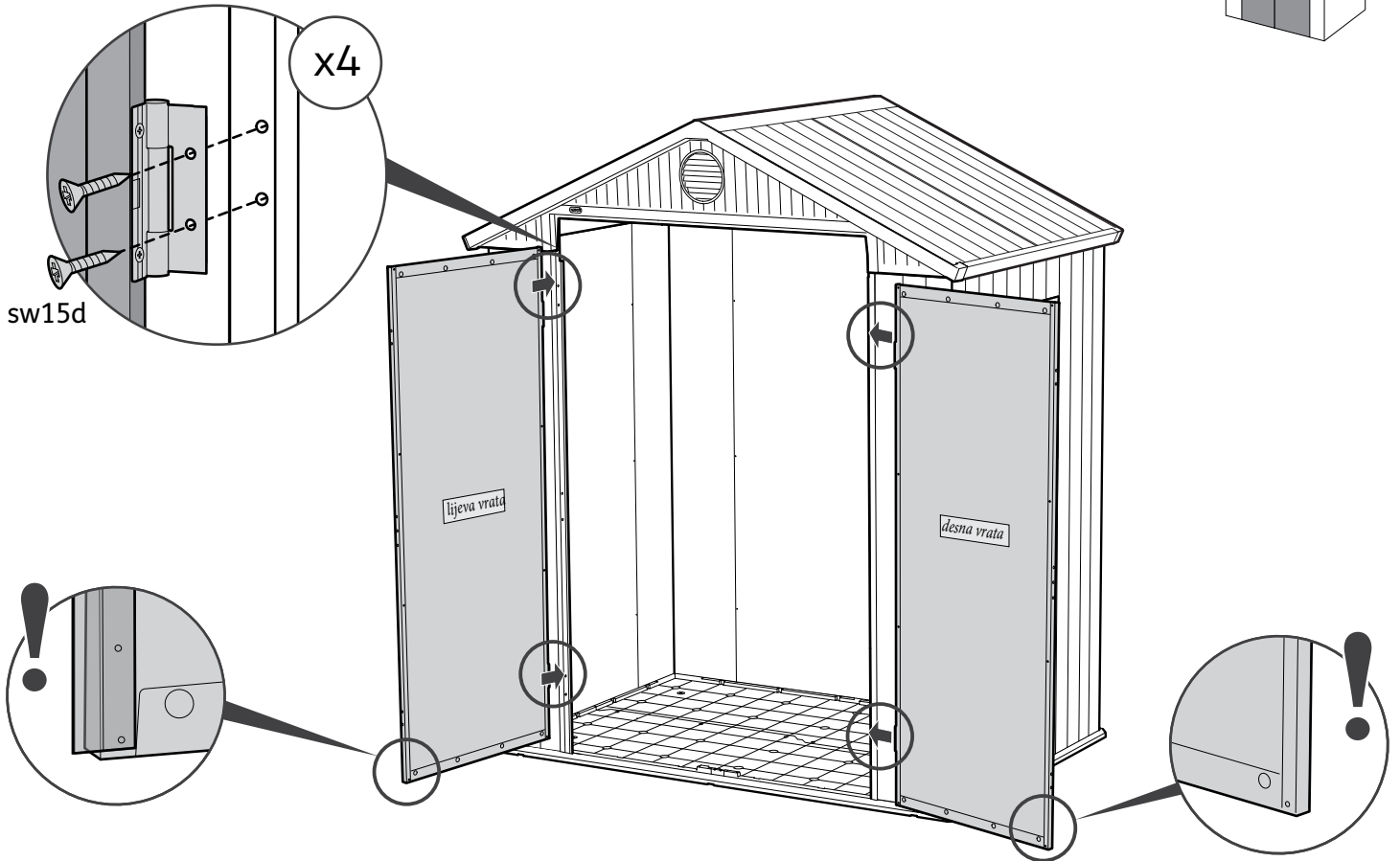
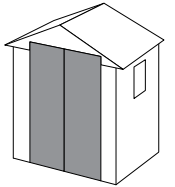

58



DRLH (x1)



DRLM (x1)



sw15d (x5)

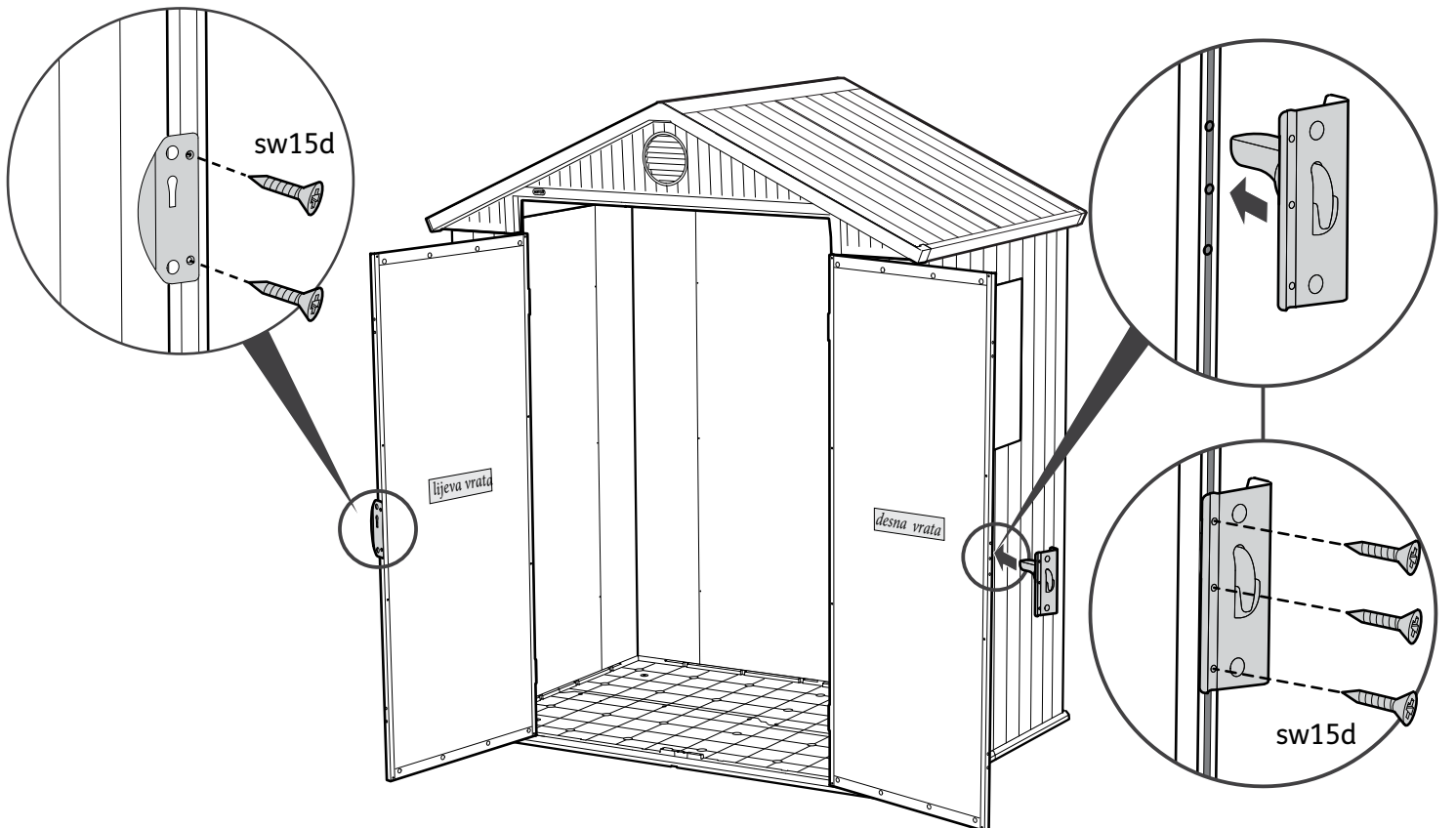
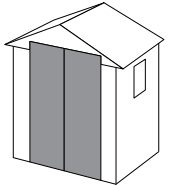

59



D6L (x2)



sw15d (x4)

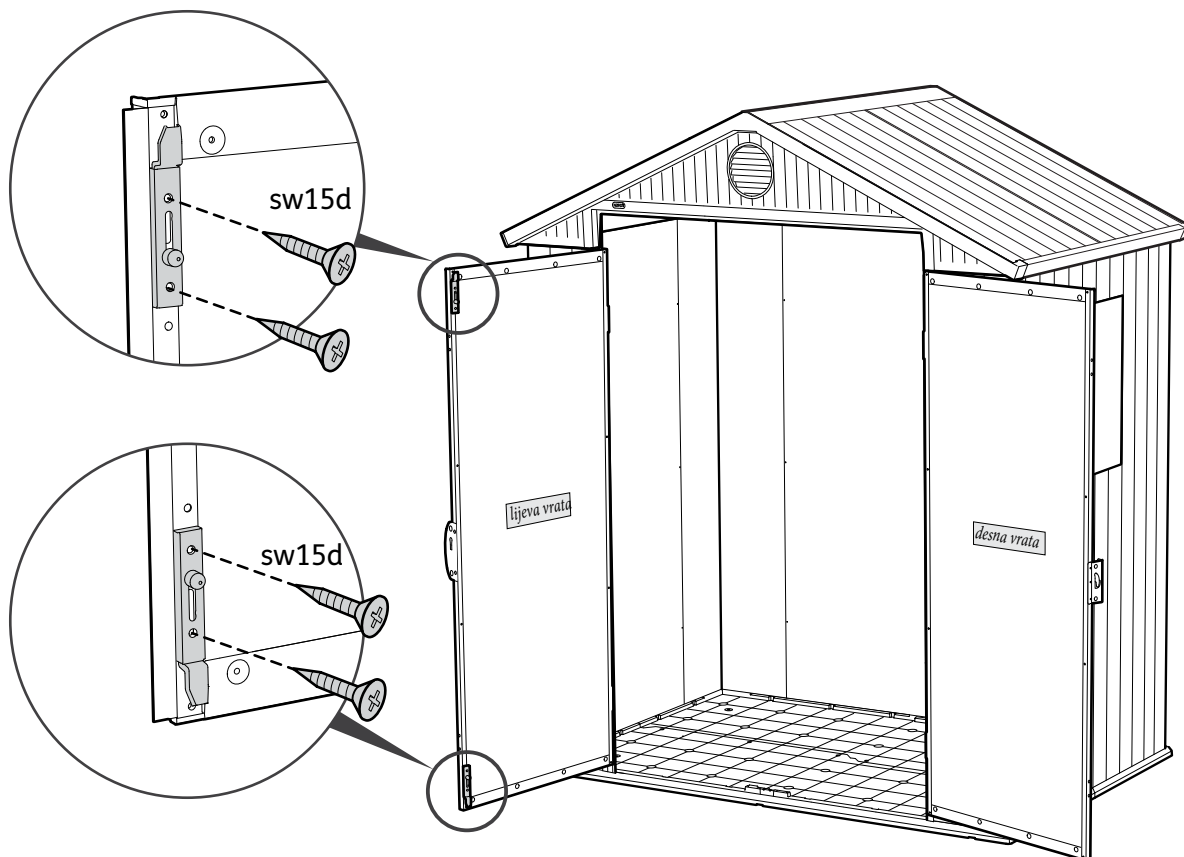
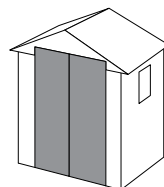

POSTAVLJANJE PROZORA

60



WI-OUT (X1)

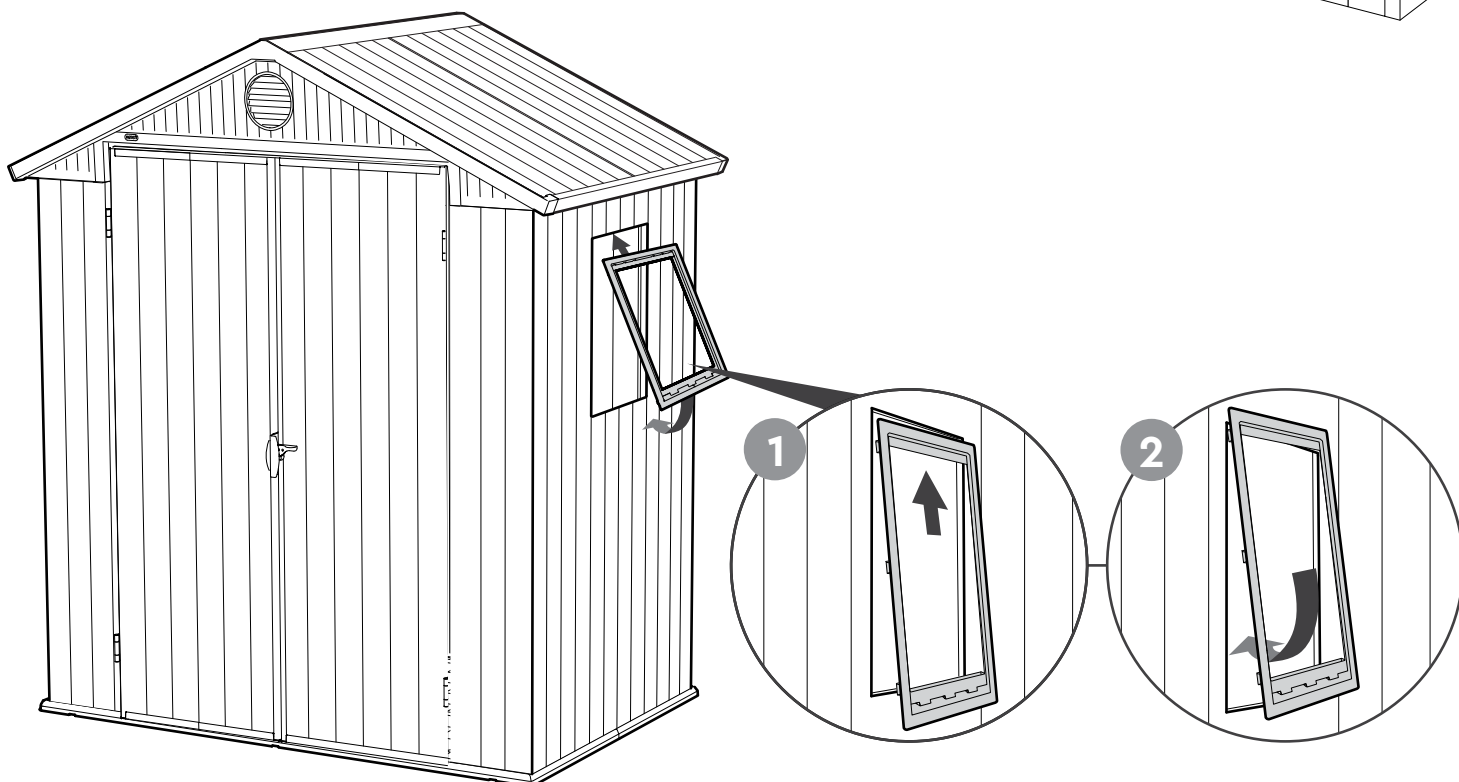
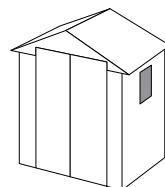

61

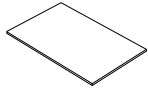

MDG (X1)

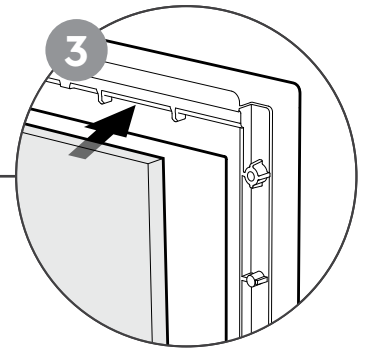
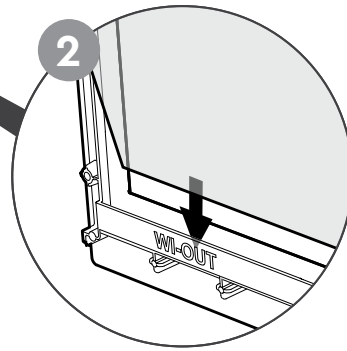
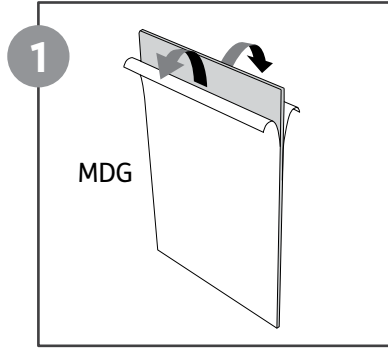
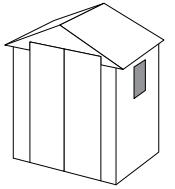

62



WI-IN (x1)



sc12t (x8)

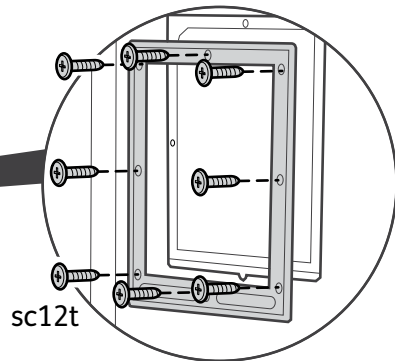
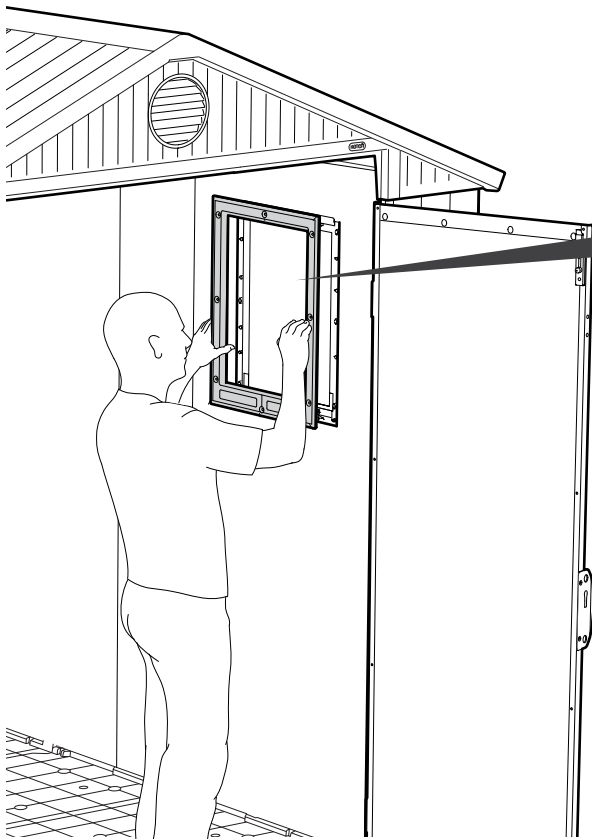
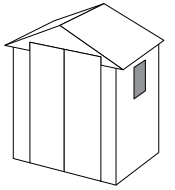

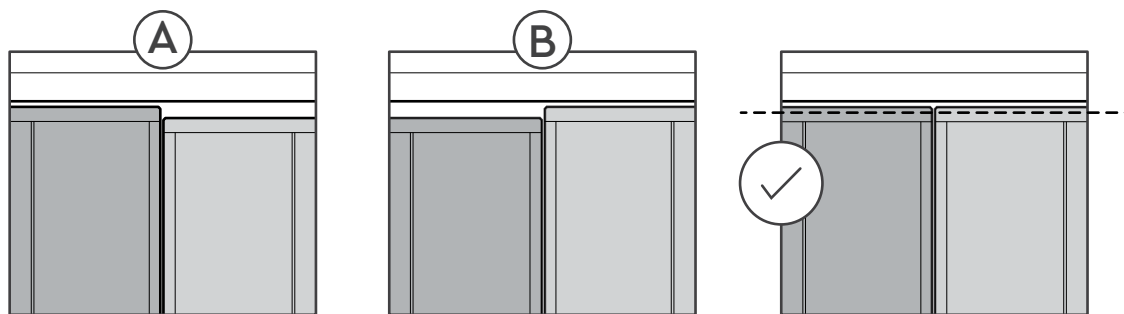

Ako kućica nije ravna, upotrijebite podloške s obje strane kućice ili vrata.



OPCIONALNO

Sidrenje kućice na temelj

Usidrite kućicu na temelj tako što ćete izbušiti rupe u podnici kućice na unaprijed označenim mjestima i pričvrstite je na temelj pomoću odgovarajućih vijaka (vijci nisu uključeni u opseg isporuke).

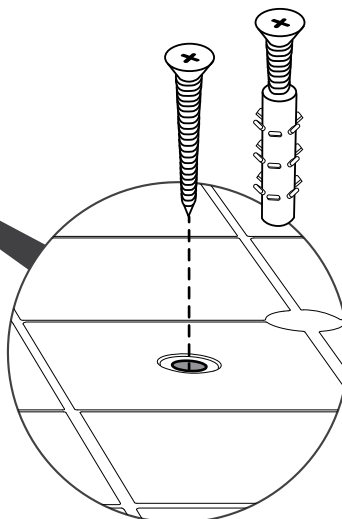
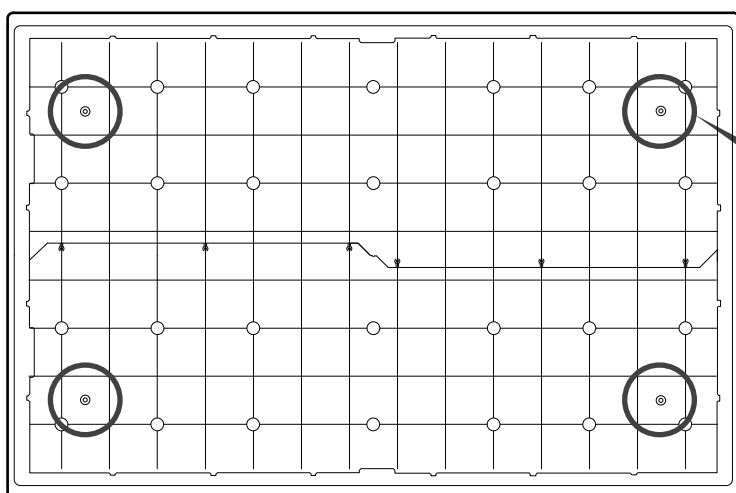
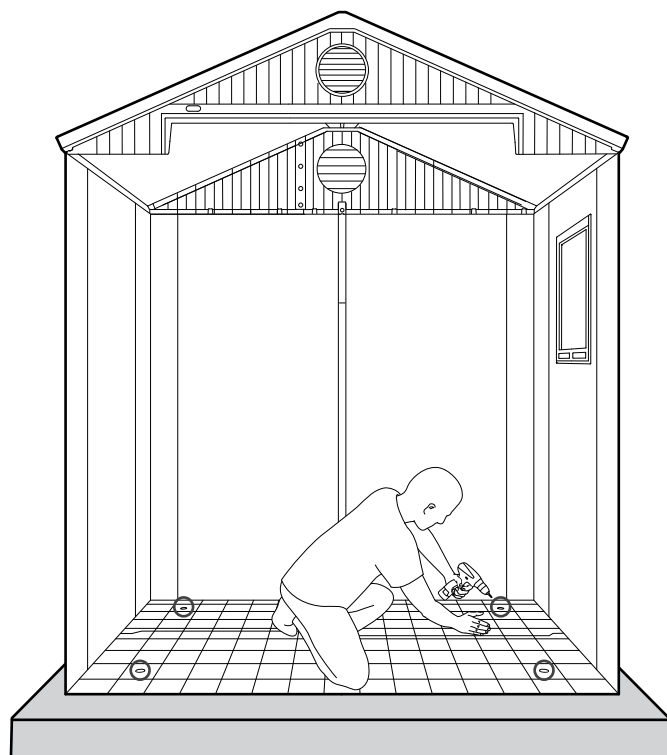

ODRŽAVANJE I SIGURNOSNE NAPOMENE

- Kućica je namijenjena isključivo za pohranu predmeta. Kućica nije prikladna za stanovanje.
- Preporučujemo da kućicu pričvrstite na nepomični objekt ili usidrite u tlo kroz rupe (na unaprijed označenim mjestima) na podnici kućice pomoću odgovarajućih vijaka (vijci nisu uključeni u opseg isporuke).
- Kućicu ne postavljajte po vjetrovitom ili hladnom vremenu.
- Redovito provjeravajte je li kućica stabilna i je li mjesto postavljanja ravno.
- Budite oprezni kada rukujete s dijelovima koji imaju čelične rubove.
- Za postavljanje i održavanje kućice koristite samo alate koji su navedeni u uputama za postavljanje.
- Izbjegavajte košnju kosilicom i trimerom u direktnom okruženju kućice.
- Nosite zaštitne naočale i prilikom uporabe električnih uređaja uvijek se pridržavajte uputa proizvođača.
- Kućicu čistite s vrtnim crijevom ili blagim sredstvom za čišćenje. Ne koristite tvrdu četku ili abrazivna sredstva za čišćenje, uključujući odmašćivače i sredstva za čišćenje na bazi ulja ili acetona jer ta sredstva stvaraju mrlje i mogu oštetiti kućicu.
- Ne pohranjujte vruće predmete u kućici kao što su nedavno uporabljani roštilj ili plamenik za lemljenje i hlapljive kemikalije.
- Ne naslanjajte teške predmete na zidove kućice jer cijela kućica može izgubiti oblik.
- Uklonite snijeg s krova i nakupljeno lišće. Velike količine snijega mogu oštetiti kućicu te stvoriti opasnost prilikom ulaska.
- Smjer vjetra također je važan čimbenik kojeg morate uzeti u obzir prilikom postavljanja kućice. Izbjegavajte izloženost vjetru, pogotovo na strani vrata. Vrata uvijek moraju biti zatvorena i zaključana kada ne koristite kućicu kako biste izbjegli oštećenja uzrokovana vjetrom.
- Ne penjite se na krov kućice ni u kojem slučaju.
- Obratite se mjesnoj upravi je li potrebna dozvola za postavljanje kućice.

10 GODINA OGRANIČENOG JAMSTVA

Vaša Keter kućica (proizvod) izrađena je pod točnom kontrolom i strogim nadzorom od visokokvalitetnog materijala, koji se može reciklirati.

Ukoliko se pojave problemi s proizvodom, reklamaciju pošaljite Keter službi za korisnike na našoj webstranici (www.keter.com) ili nam se obratite telefonskim putem.

U ograničeno jamstvo od 10 godina uključeni su nedostaci nastali prilikom proizvodnje ili nedostaci materijala. Jamstvo vrijedi od datuma kupnje. (Izraz "nedostaci" definira se kao oštećenje koje ograničava uporabu proizvoda).

Ovo jamstvo ne obuhvaća nedostatke, koji su nastali kao rezultat normalne uporabe i tragove trošenja, ogrebotine ili pukotine, koje su nastale uporabom proizvoda, kao i promjene u boji, pojavu hrđe, štetu, koja je nastala neprikladnom uporabom, pogrešnom uporabom, nepažnjom, izmjenama, bojanjem, pomicanjem ili premještanjem proizvoda i "rezultate prirodnih nepogoda", u što se ubraja tuča, svaki oblik oluje, poplave i požari te posljedična ili slučajna šteta.

Prilikom postavljanja i rukovanja, koje nije u skladu s uputama, uvjetima i ograničenjima navedenim u ovom uputama, izgubit ćete pravo na jamstvo. To također vrijedi i za uporabu u komercijalne i javne svrhe. Tvrtka Keter nije odgovorna za bilo kakvu štetu uzrokovanu trećom stranom te za štetu i gubitak predmeta unutar ili u blizini kućice. Nakon podnošenja dokaza o kupnji i dokaznog materijala o nedostaku proizvoda te uz pravovremenu obavijest o nedostatku, Keter će za vrijeme trajanja jamstva nakon vlastite procjene zamijeniti manjkave dijelove ili će vratiti proporcionalni iznos cijene na osnovi amortizirane osnovice za vrijeme trajanja jamstva.



AKO NEKI DIJELOVI NEDOSTAJU ILI SU OŠTEĆENI, MOLIMO NE VRAĆAJTE PROIZVOD U TRGOVINU. Molimo, prijavite se na našu webstranicu ili kontaktirajte našu službu za korisnike na:

WWW.KETER.COM

SAD, Kanada: (EN / FR)

Tel.: +1877-638-7056
email: NACS@keter.com
Pon. - pet. | 8am - 6pm ET
Lundi-Vendredi 8h -18h
Sub. - ned. | 9am - 6pm ET
Samedi-Dimanche 9h-18h

UK: (EN)

Tel: +44-121-506-0008
email: CSUK@keter.com
Keter UK Ltd
Cardrew Way, Redruth, Cornwall
TR15 1ST
Pon. - pet. | 8:30am - 5pm

Švicarska:

Tel: +41-62-767-00-50
email: info@neogard.ch

Francuska:

Votre produit ayant été acheté dans une enseigne, qu'elle soit physique ou sur internet, c'est auprès de cette enseigne que vous devez faire votre demande SAV.

Australija:

Tel: 03 9544 6999
Email: keteraus@keter.com
28 Buckland St,
Clayton, Victoria 3168
Pon. - pet. | 9am - 5pm

Španjolska: (SP)

Tel: +34-949-277-421
Avenida Conde de Romanones 6-b.
Polg. Ind. Miralcampo,
19200 Azuqueca de Henares -
Guadalajara, Spain
Pon. - pet. | 9am - 7pm

Njemačka / Austrija

Tel: +49 (0) 481-21-22-46-3
email: service@keter-ersatzteile.de

Italija

email: info.it@keter.com

Iberia

Tel: +949-27-74-21
email: spvketer@carcaba.com

Izrael

Tel: 1-700-70-6015
email: Ketercs@keter.com

Južna Afrika

Tel: 0861-866-766
email: info@keter.co.za
Website: za.Keter.com

Poljska

Tel: +48 59 84 19 892
email: Service.poland@keter.com

Mađarska

Tel: +36 52 565 920
email: Service.hungary@keter.com

Skandinavija

Tel: +48 59 84 19 892
email: Service.nordic@keter.com

고객센터

Tel: 031-767-2492
E-mail: info@keter.co.kr
월 - 금 | 9:00am - 05:30pm

Ostale europske zemlje

Tel: +31-1612-28300
email: service@keter.com
Pon. - pet. | 8:30am - 5pm

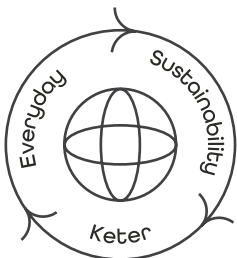

KETER

Le développement durable au quotidien | Sostenibilidad día a día



Designed to Last | Conçu pour durer | Diseñado para durar | Auf Langlebigkeit ausgelegt | Duurzaam ontworpen | Progettato per durare | Projetado para durar



Recyclability & Recycling | Recyclabilité et Recyclage | Reciclabilidad y reciclable | recyclefähig & recycelt | Recyclebaarheid & recycling | Riciclabilità e Riciclo | Reciclabilidade e Reciclagem



Community | Communauté | Comunidad | Community | Community | Comunità | Comunidade



Responsible Manufacturing | Fabrication responsable | Producción responsable | Verantwortungsbewusste Herstellung | Verantwoorde productie | Produzione responsabile | Fabricação responsável

Made in Israel by | Fabriqué en Israël par | Fabricado en Israel por | Hergestellt in Israel von | Gemaakt in Israël door | Realizzato in Israele da | Fabricado em Israel por
Keter Plastic Ltd., 1 Sapir St. Industrial Area, Herzliya 4685205, Israel

KETER