

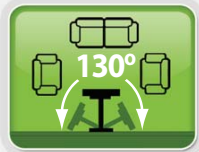

NEO

S E R I E S

innovative, safe and attractive

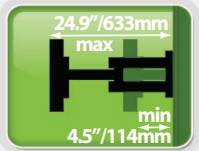

TECHNICAL DATA SHEET: LNRFM600XL-RO
FULL MOTION MULTI ARM TV WALL MOUNT

Innovative, safe and attractive

Ross Neo Series TV mounts provide a safe and secure mounting solution for your Flat panel TV.

Our unique NEO protection pads give protection to your TV from scratches, while improving audio clarity by reducing unwanted vibration.

Features:

- Cantilever 6 arm LCD Mount for smooth, level swivel adjustment
- Perfect for all round viewing
- Push back flat to wall when not in use
- Variable tilt to reduce screen glare
- Safety locking screw
- Spirit level for level installation
- Neo protective pads

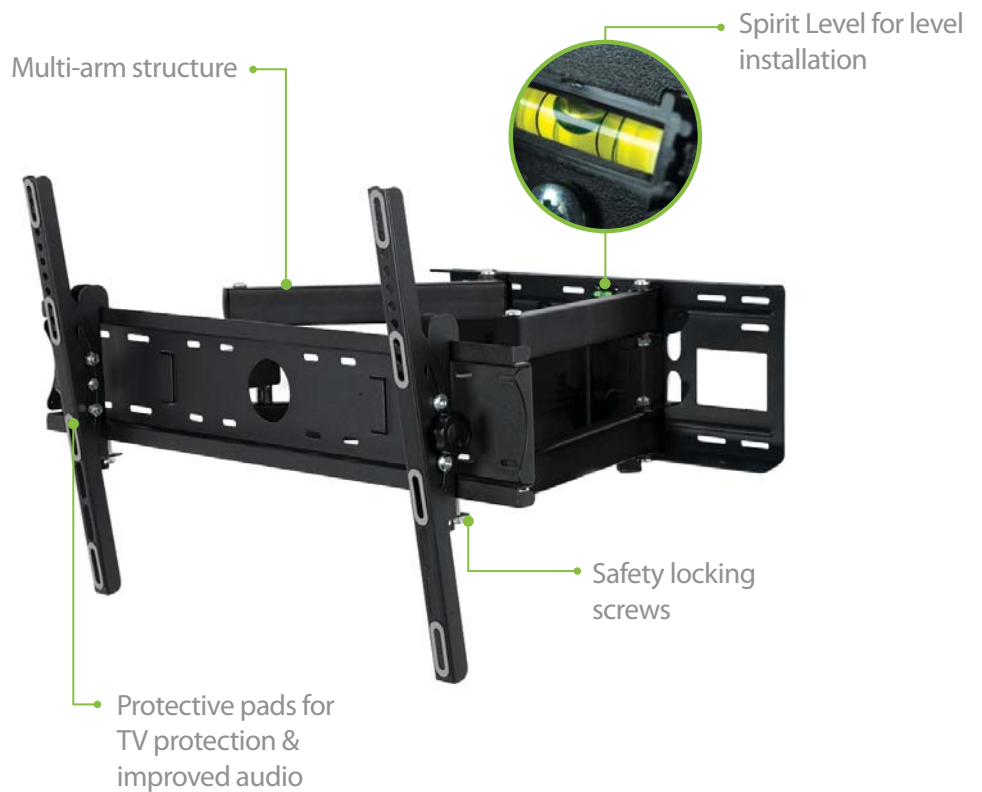

Technical Specifications:

Max Load	Distance from Wall		Swivel Range	Tilt Range	No. of Articulation Points	Mounting pattern	VESA Compatible:
	Max (Extended)	Min (folded)					
40Kg/ 88lbs	633mm/ 24.9"	114mm/ 4.5"	130°	+/-15°	6	Double Stud & Solid Wall	100 x 100 to 600x400





TECHNICAL DATA SHEET: LNRFM600XL-RO
FULL MOTION MULTI ARM TV WALL MOUNT

VESA Details

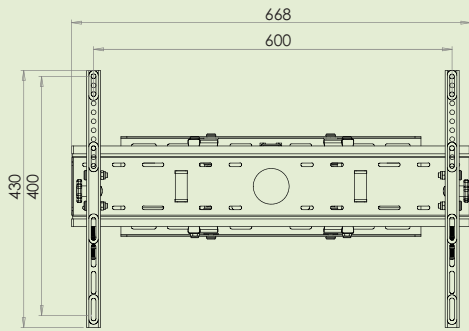

Mounting Hole Details

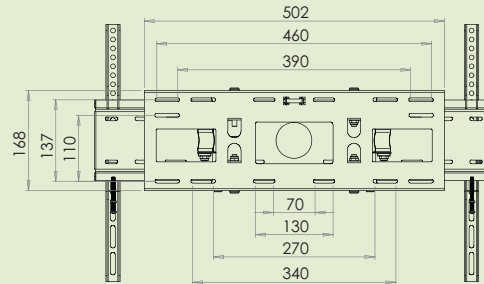

Min Profile



±65°

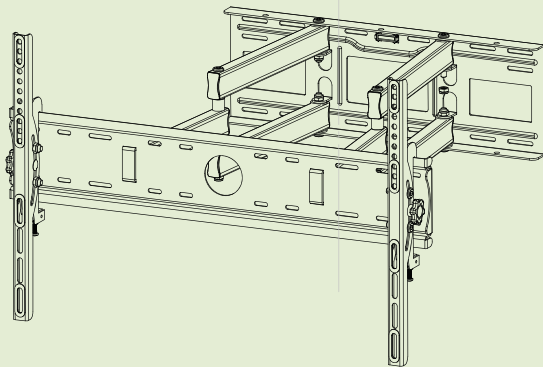

Max Extension

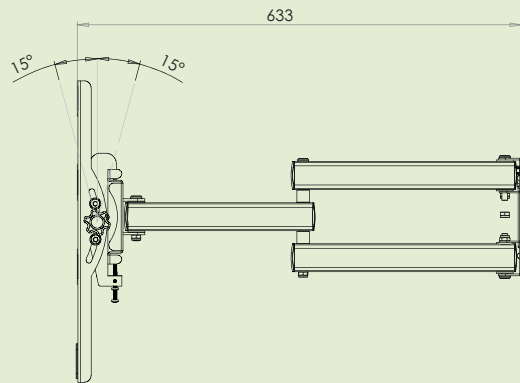

All dimensions are in mm

Packaging Information:

Product Number	Description	Product Packaging		Outer Packaging		
		Type	Barcode	Type	Qty in Box	Barcode
LNRFM600XL-RO	Full Motion Multi Arm TV Wall Mount	Colour Gift Box	5015056 518671	Brown Outer with Label	2	05015056 500201

Weight & Dimensions:

Product			Product Box			Outer Box		
Extended	Folded	Net Weight	Dimensions	Gross Weight	Cubic	Dimensions	Gross Weight	Cubic
66.8 x 43 x 63.4 cm	81.2 x 43 x 11.2 cm	7.574kg	84 x 24 x 7 cm	8.5kg	0.0141m ³	85.5 x 26 x 17.5 cm	18kg	0.0389m ³
26.30" x 16.93" x 24.96"	31.97" x 16.93" x 4.41"	16.66lbs	33.07" x 9.45" x 2.76"	18.7lbs	0.4984ft ³	33.66" x 10.24" x 6.89"	39.6lbs	1.3738ft ³