

Ante

12mm 1,82×2,20 F1/DPV

47481P043 - B-001957

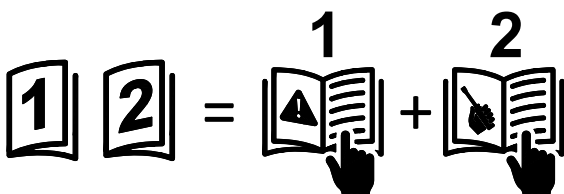
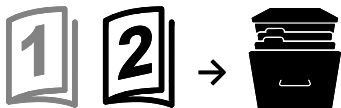
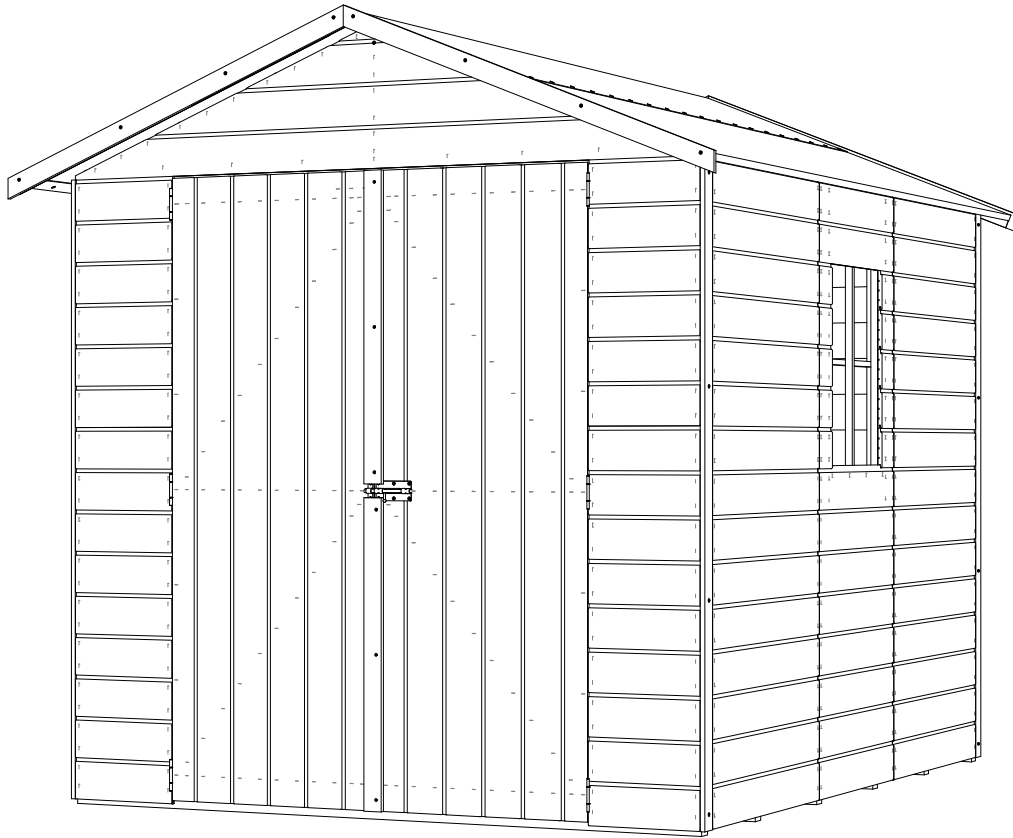

- (EN) **Assembly notice - keep for later reference.**
 (FR) **Notice de montage à conserver pour consultations ultérieures.**
 (NL) **Te bewaren gebruiksaanwijzingen voor latere raadplegingen.**
 (DE) **Montageleitung nicht wegwerfen, bewahren Sie diese für später.**
 (IT) **Manuale di montaggio da conservare per ulteriori consultazioni.**
 (ES) **Debe conservar las instrucciones de montaje para consultas posteriores.**
 (PT) **Instruções de montagem a guardar para consultas futuras.**



- (EN) **Tools needed to provide before assembly.**
 (FR) **Outillage nécessaire à prévoir avant le montage.**
 (NL) **Te voorziene gereedschappen bij aanvang van de montage.**
 (DE) **Für die Montage notwendiges Werkzeug vorsehen.**
 (IT) **Utensili necessari da prevedere prima del montaggio.**
 (ES) **Preparar herramientas necesarias antes del montaje.**
 (PT) **Prepare as ferramentas necessárias antes da montagem.**

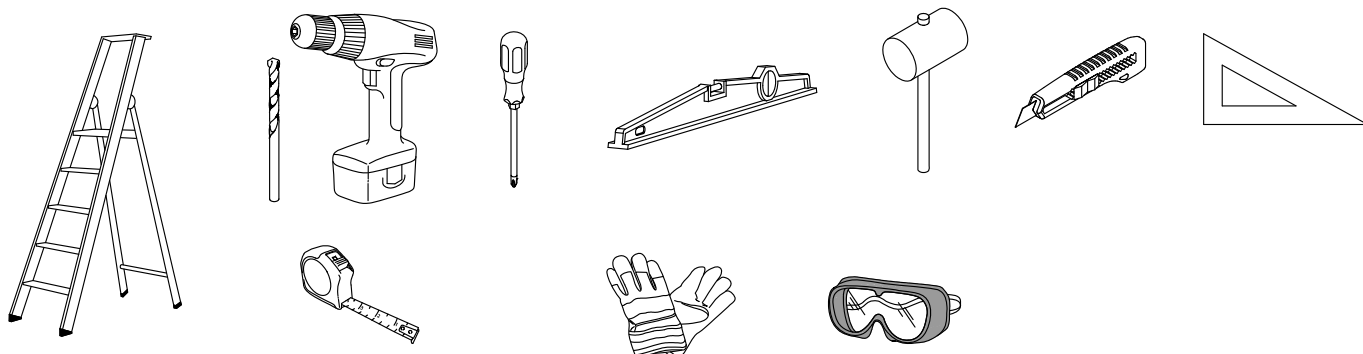

- (EN) **Significant complements not included.**
 (FR) **Compléments importants non inclus.**
 (NL) **Belangrijke aanvullingen niet inbegrepen.**
 (DE) **Wichtige Zubehörteile nicht im Lieferumfang.**
 (IT) **Supplementi importanti non inclusi.**
 (ES) **Complementos importantes no incluidos.**
 (PT) **Complementos importantes não incluídos.**



- (EN) *Glue for the roof.*
 (FR) *Colle pour le feutre bitumeux.*
 (NL) *Lijm voor het dak.*
 (DE) *Klebstoff für das Dach.*
 (IT) *Colla per tela buttumata.*
 (ES) *Pegamento para tela asfáltica.*
 (PT) *Cola para tecido asfáltico.*

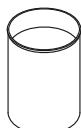

- (EN) *Wood preserver for the outside : 2 layers before assembly.*
 (FR) *Protection pour le bois en extérieur : 2 couches avant montage.*
 (NL) *Bescherming van het hout: 2 lagen voor de montage.*
 (DE) *Holzschutz für Aussenanwendung: 2 Lagen vor dem Zusammenbau.*
 (IT) *Protezione per il legno in esterno : due mani prima del montaggio.*
 (ES) *Protección para la madera de exteriores: 2 manos antes del montaje.*
 (PT) *Proteção para madeira exterior: 2 demãos antes da montagem.*

Silicone / Mastic

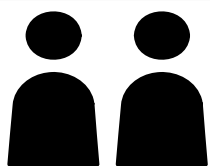
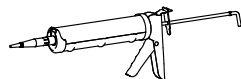

- (EN) **2 persons**
 (FR) **2 personnes**
 (NL) **2 personen**
 (DE) **2 Personen**
 (IT) **2 persone**
 (ES) **2 personas**
 (PT) **2 pessoas**



- (EN) **Predrill**
 (FR) **Préforer**
 (NL) **Voorboren**
 (DE) **Vorbohren**
 (IT) **Preforare**
 (ES) **Preforar previamente**
 (PT) **Perfuração**

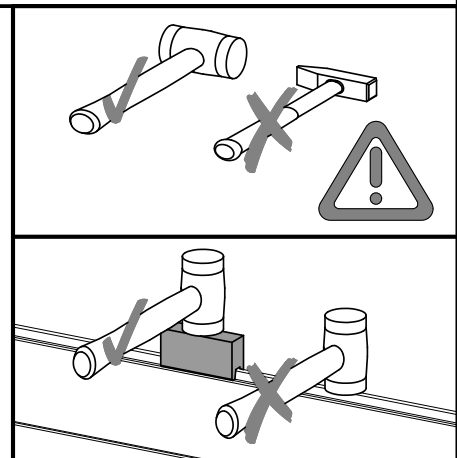

Ante

12mm 1,82×2,20 F1/DPV

47481P043 - B-001957

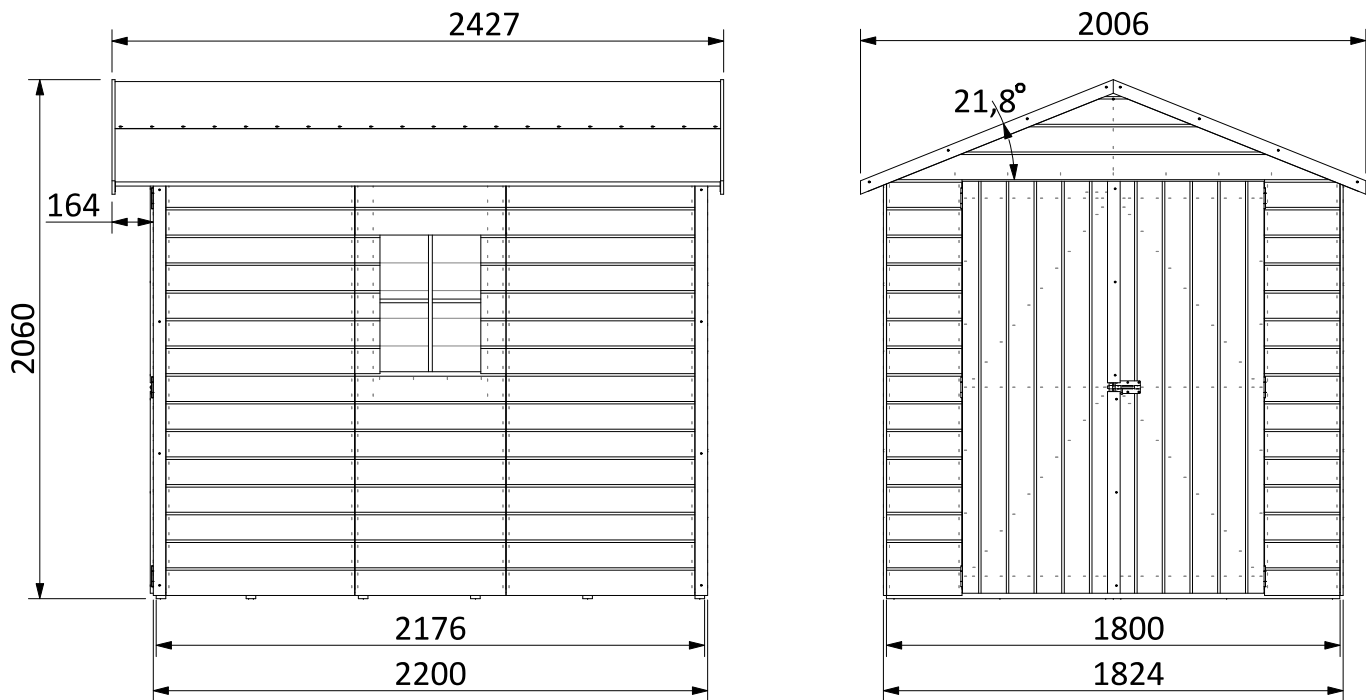

- (EN) Laying on a perfectly flat and level concrete slab (*not included*)
- (FR) Pose sur dalle béton parfaitement plate et de niveau (*non incluse*)
- (NL) Plaatsen op een perfect vlakke betontegel (*niet inbegrepen*)
- (DE) Montage auf einer ebenen, befestigten Fläche (*Material nicht inbegriffen*)
- (IT) Posare su pavimenti in cemento perfettamente in piano e livellato (*non incluso*)
- (ES) Colocar sobre losa de hormigón perfectamente plana y nivelada (*non incluida*)
- (PT) Montagem sobre laje de betão perfeitamente plana e nivelada (*não incluído*)

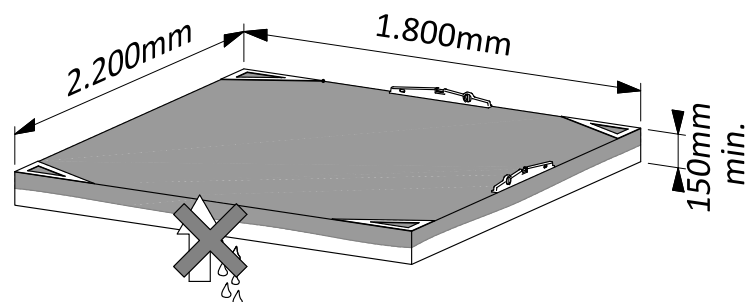

503252 : x1
29x59/2176mm

501780 : x4
12x50/1080mm/68,2°

470022 : x2
1800x360/12mm

500085 : x2 (*)
24x38/1799mm

470059 : x1
600x1612/12mm

500003 : x4
12x50/1650mm

470101 : x2
300x1612/12mm

470133 : x1
596x1635/12mm

501659 : x2
12x50/800mm

600507 : x1
376x1800/14mm

500085 : x6 (*)
24x38/1799mm

600502 : x4
900x1060/14mm

600506 : x2
600x1060/14mm

470004 : x2
900x1612/12mm

500078 : x2
24x38/1350mm

500609 : x2
24x38/750mm

50957 : x3
15x20/592mm

50189 : x1
15x20/430mm

470003 : x4
750x1612/12mm

470036 : x1
600x1612/12mm

470134 : x1
596x1635/12mm

600508 : x2
900x1800/14mm

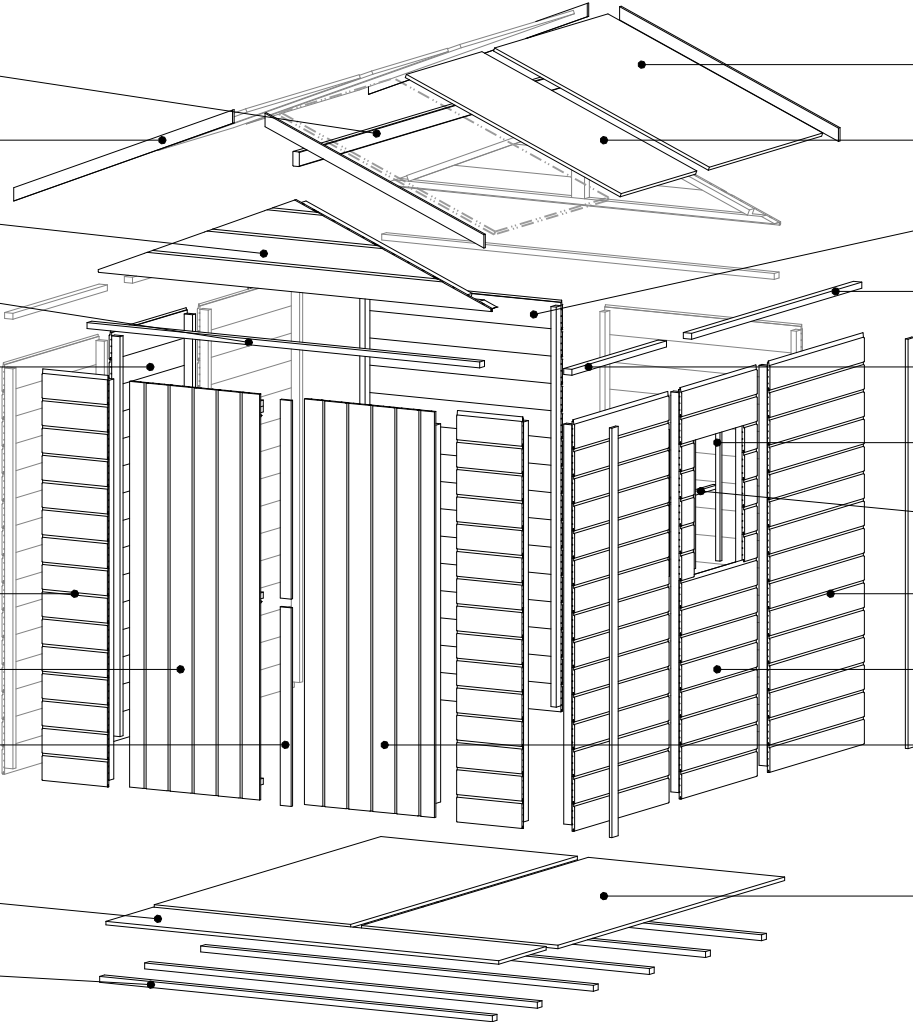

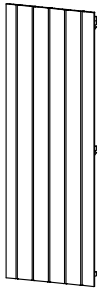

470133 : × 1 ←
596 × 1635 / 12mm
470134 : × 1 →
596 × 1635 / 12mm

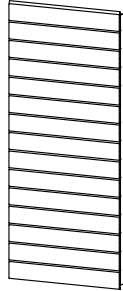

470101 : × 2
300 × 1612 / 12mm
470059 : × 1
600 × 1612 / 12mm
470003 : × 4
750 × 1612 / 12mm
470004 : × 2
900 × 1612 / 12mm



470036 : × 1
600 × 1612 / 12mm

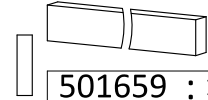

501659 : × 2
12 × 50 / 800mm
500003 : × 4
12 × 50 / 1650mm
50189 : × 1
15 × 20 / 430mm
50957 : × 3
15 × 20 / 592mm
500609 : × 2
24 × 38 / 750mm
500078 : × 2
24 × 38 / 1350mm
500085 : × 8
24 × 38 / 1799mm
503252 : × 1
29 × 59 / 2176mm

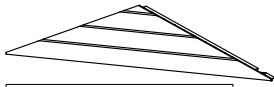

470022 : × 2
1800 × 360 / 12mm

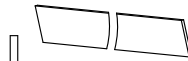

501780 : × 4
12 × 50 / 1080mm





600506 : × 2
1060 × 600 / 14mm
600502 : × 4
1060 × 900 / 14mm
600507 : × 1
1800 × 376 / 14mm
600508 : × 2
1800 × 900 / 14mm

Kit 700267			
	3009	∅3,5×12mm	16
	3012	∅3,5×25mm	54
	3023	∅4×40mm	132
	3027	∅4×60mm	72
	3029	∅4×70mm	6
Kit 700043			
	3810	∅2×15mm	88
Plexy			
	750010	425×570/1,2mm	1

Kit 700268					
	2076	×6		2155	×2
800004		1,00×9,00m		1	

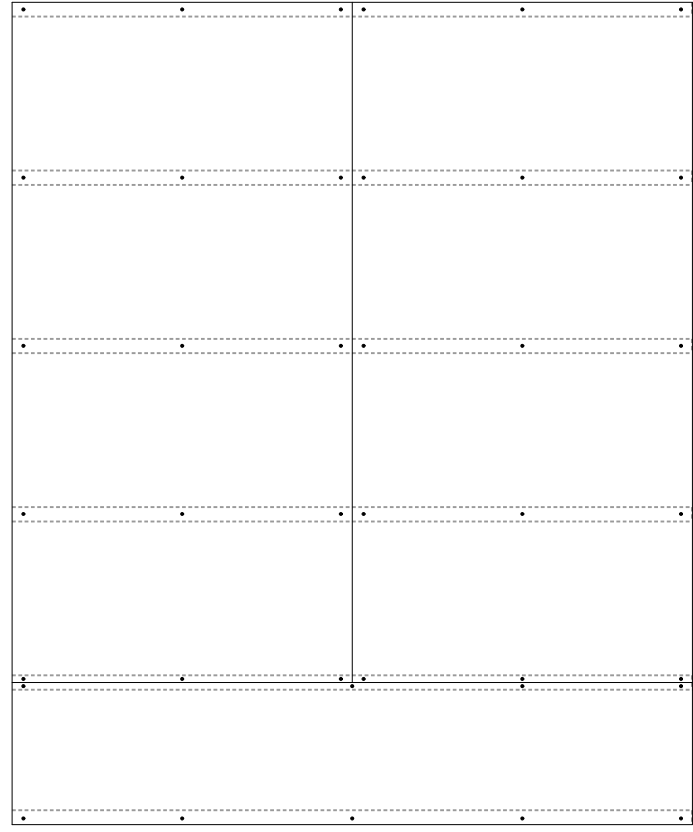
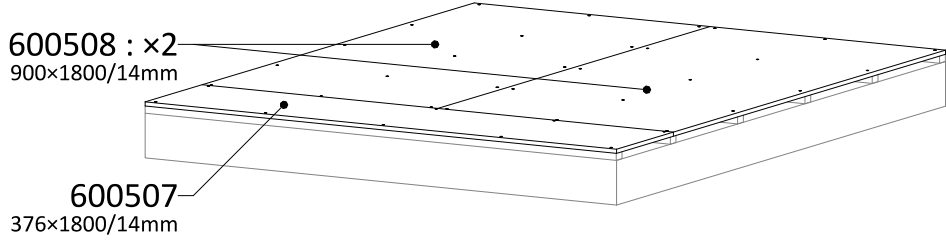
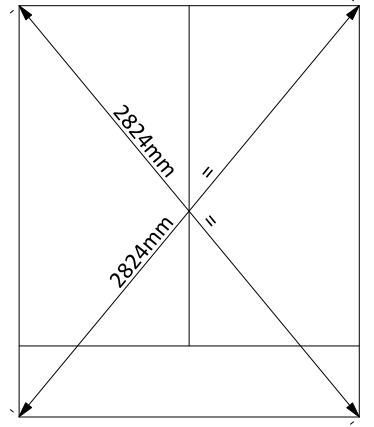
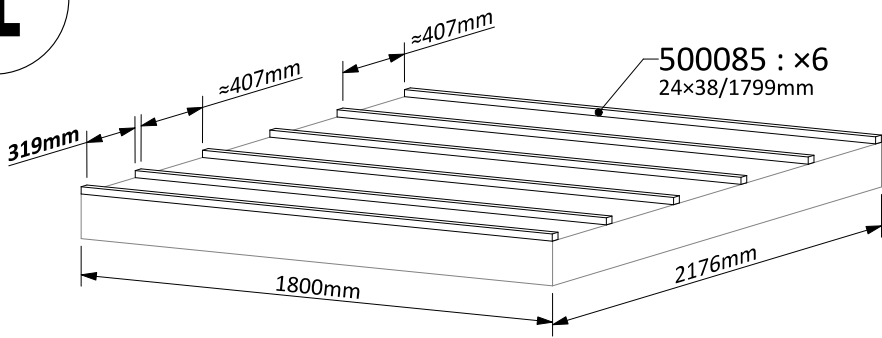
1



 **3023 : x40**
ø4x40

2

A=



500085
24x38/1799mm
+ 3027 : x4
ø4x60

470004 : x2
900x1612/12mm

3023 : x4
ø4x40



B=

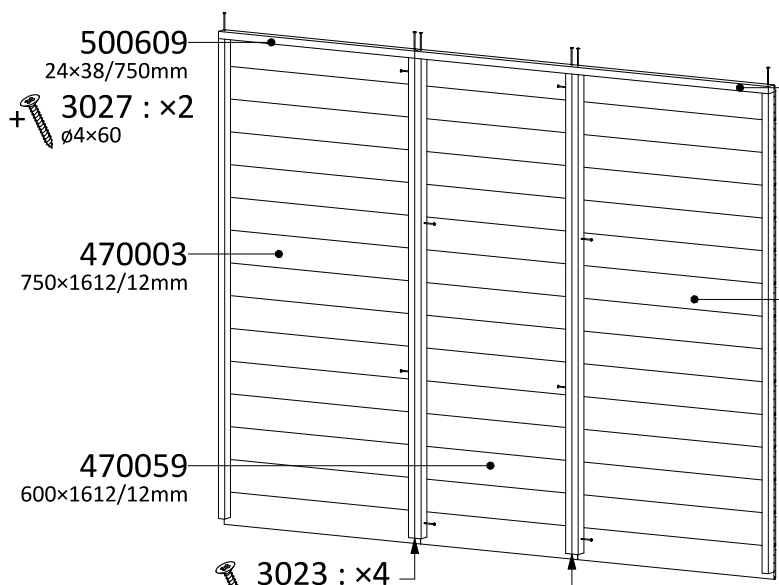

500609
24x38/750mm
+ 3027 : x2
ø4x60

500078
24x38/1350mm
+ 3027 : x4
ø4x60

470003
750x1612/12mm

470003
750x1612/12mm

470059
600x1612/12mm

3023 : x4
ø4x40

3023 : x4
ø4x40

C=

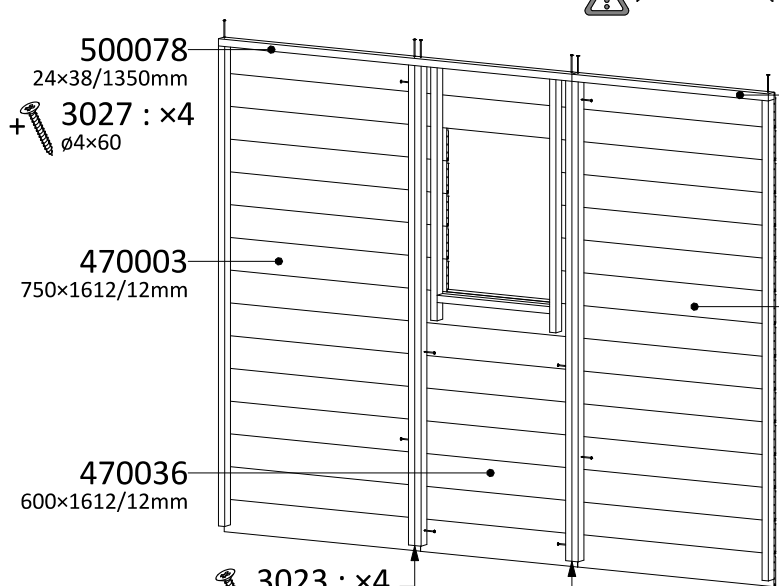

500078
24x38/1350mm
+ 3027 : x4
ø4x60

500609
24x38/750mm
+ 3027 : x2
ø4x60

470003
750x1612/12mm

470003
750x1612/12mm

470036
600x1612/12mm

3023 : x4
ø4x40

3023 : x4
ø4x40

3

500085
24x38/1799mm
+ 3027 : x4
ø4x60

470101
300x1612/12mm

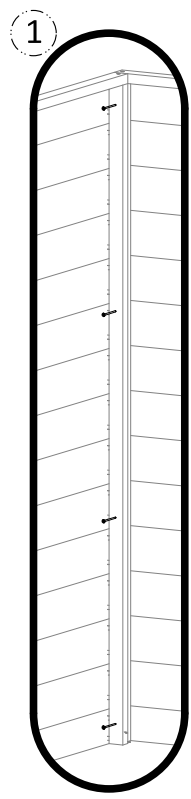
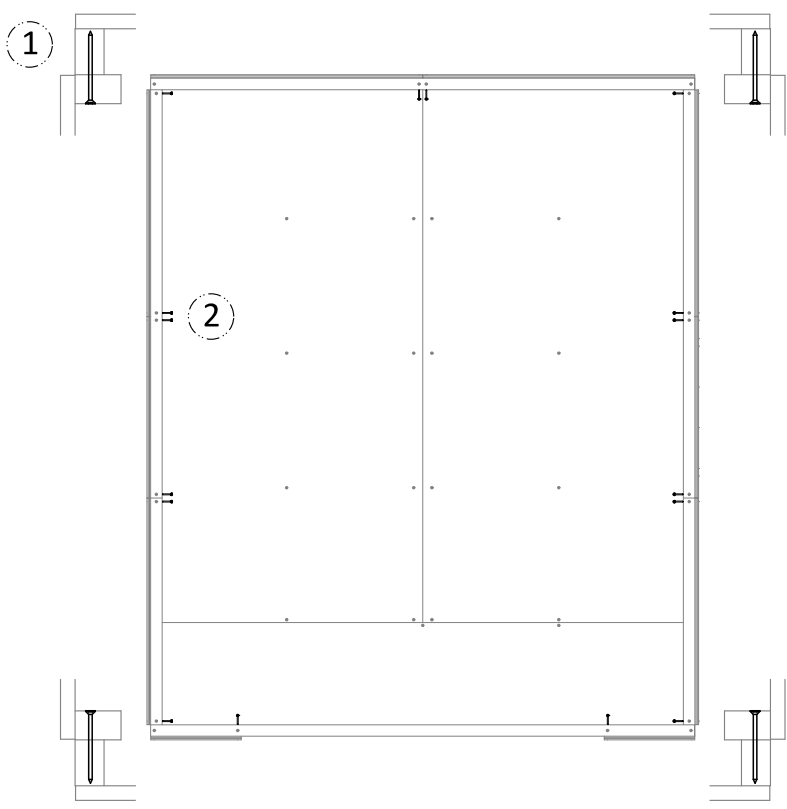
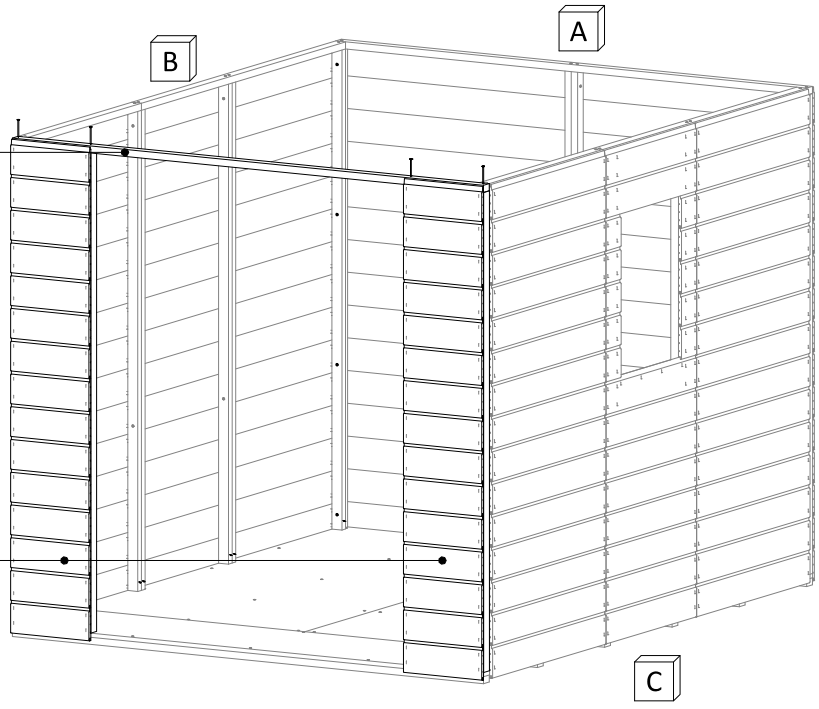

3027 : x4
ø4x60
x4

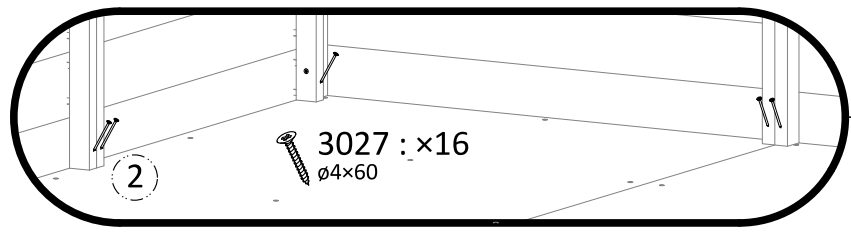

3027 : x16
ø4x60

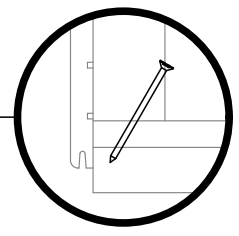

4

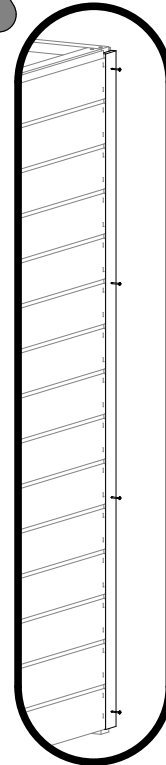
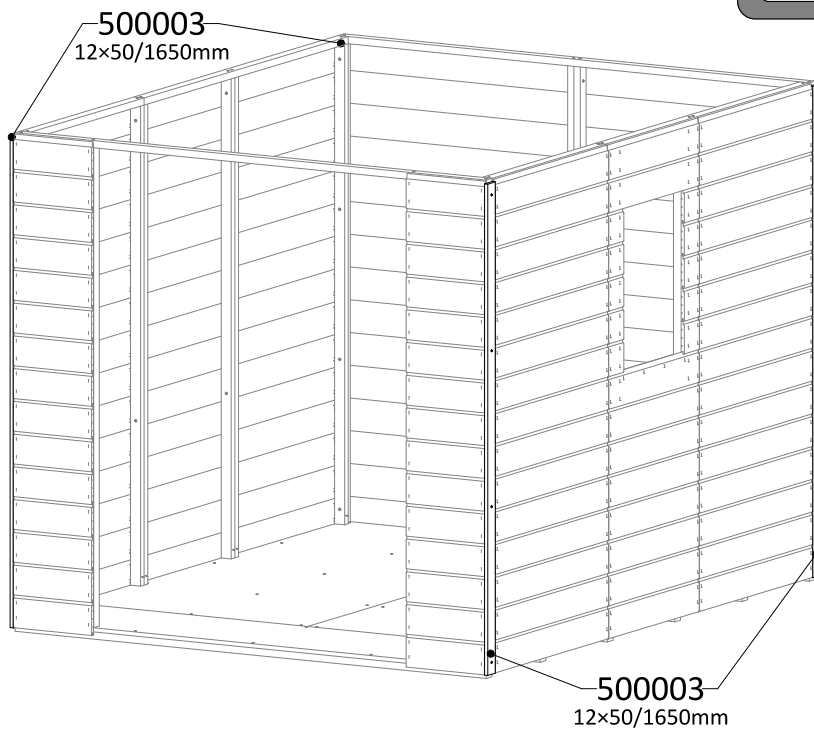

3012 : x4
ø3,5x25

x4

5

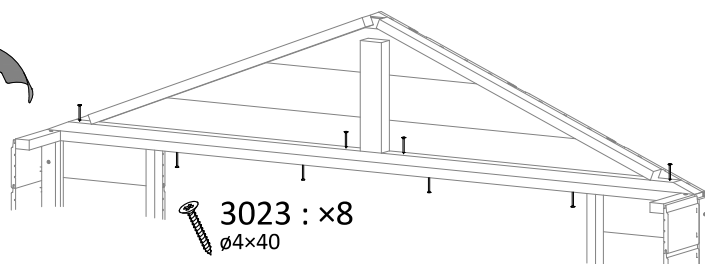
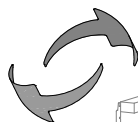
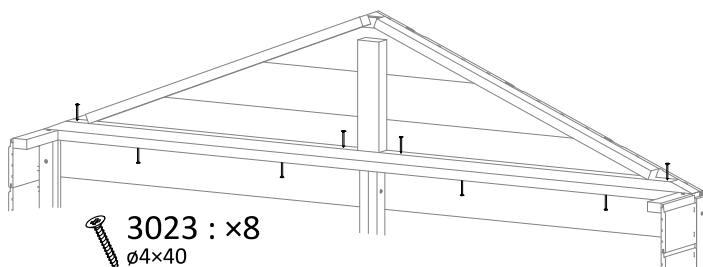
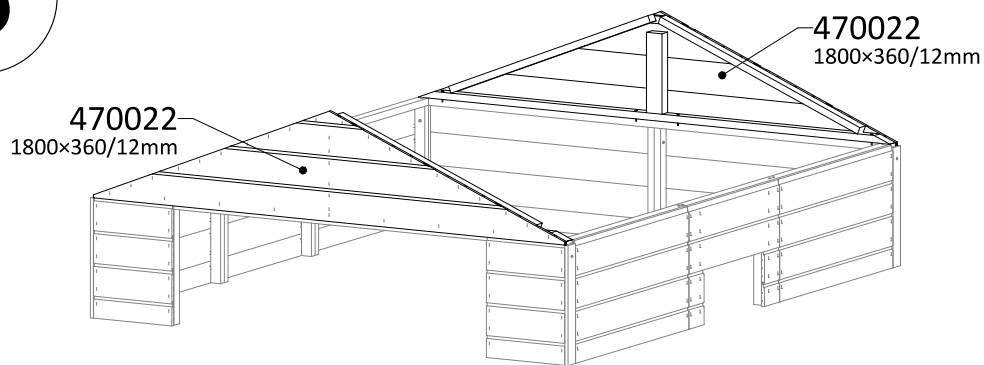

6

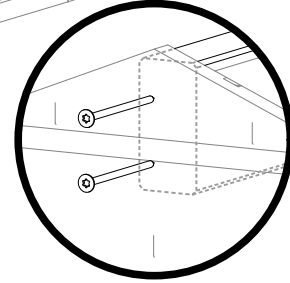
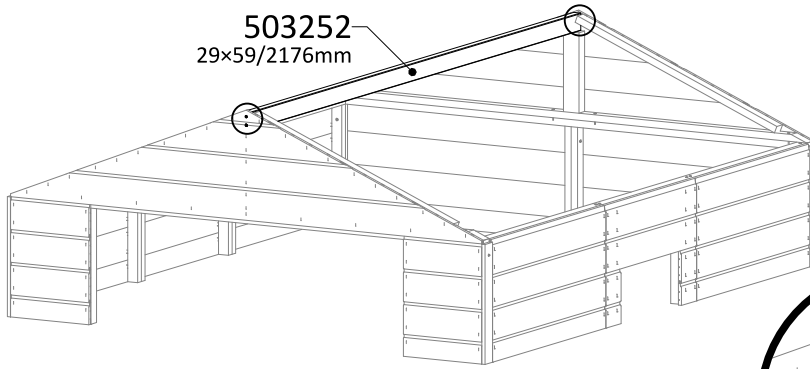

3027 : x2
 ø4x60
 x2

7

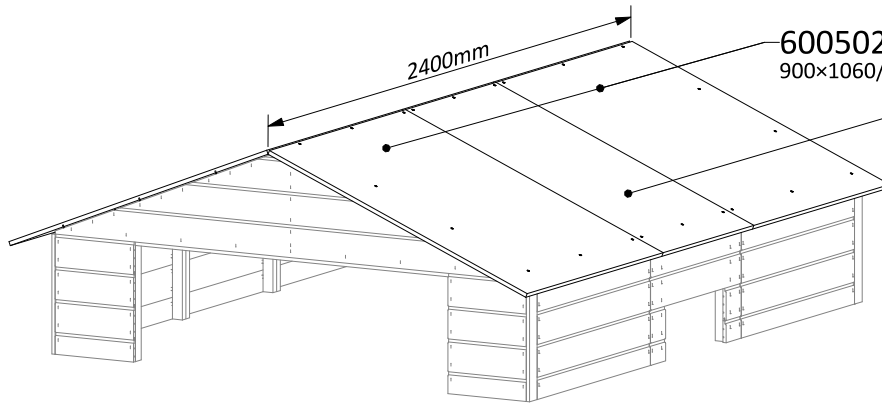

x2

3023 : x44
 ø4x40



8

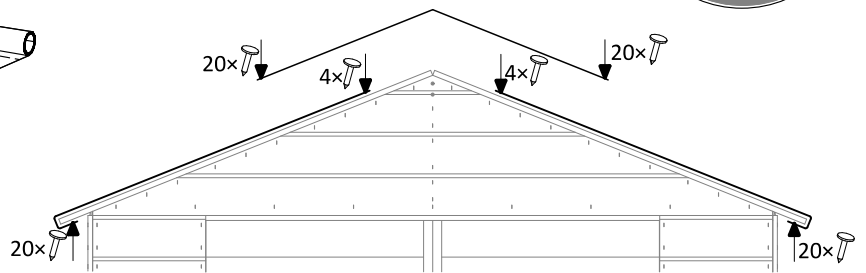
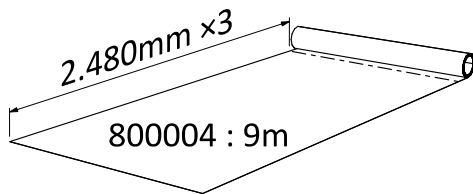

[EN] not included
 [FR] non incluse
 [NL] niet inbegrepen
 [DE] nicht einbegriffen
 [IT] non incluso
 [ES] non incluida
 [PT] não incluído
 [GR] Δεν περιλαμβάνονται

3810 : x88
 15mm

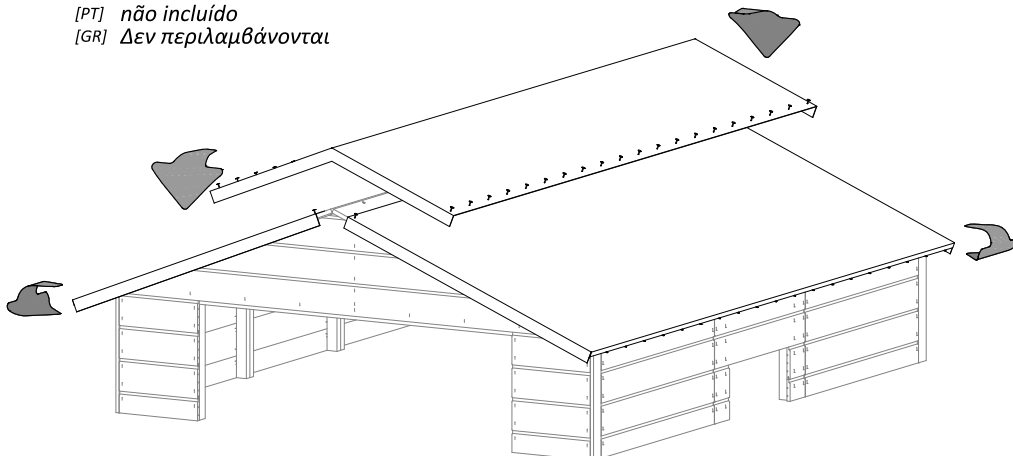

9

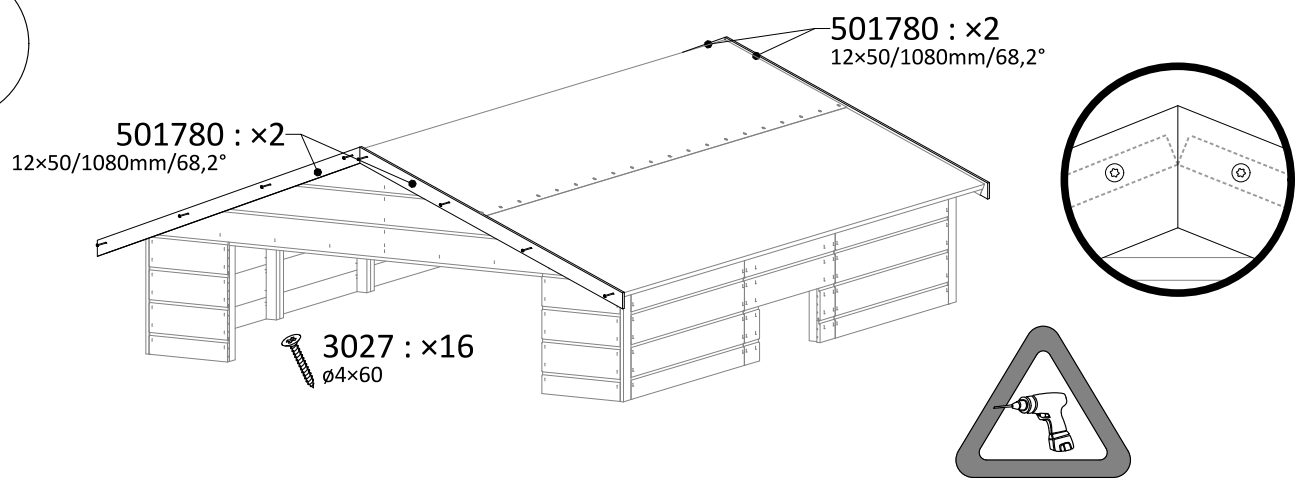

10

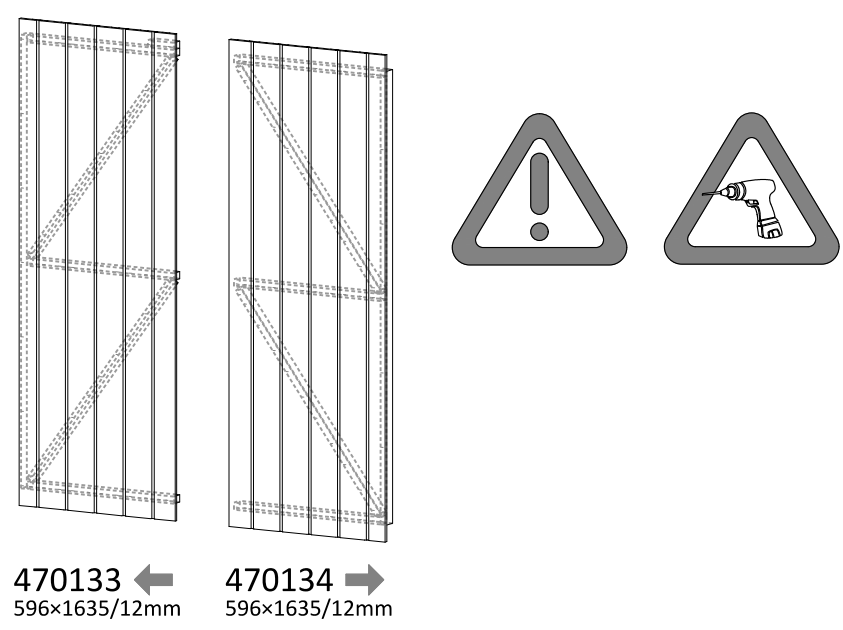

2076
x3

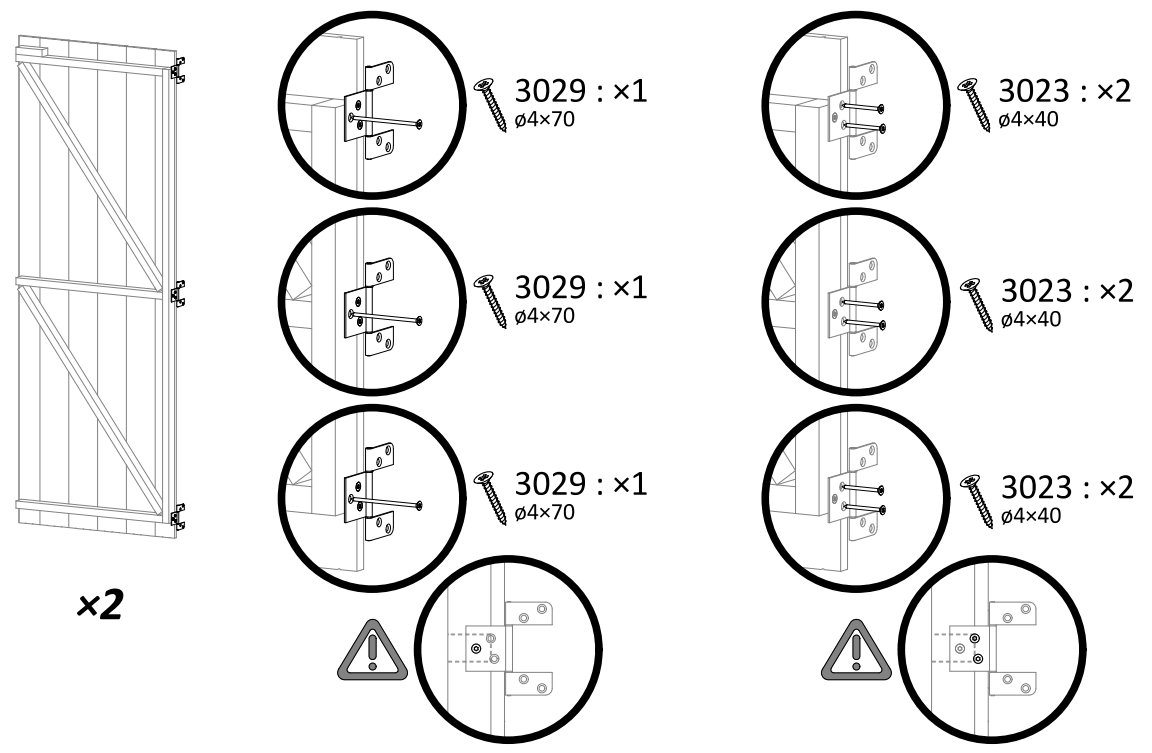

11

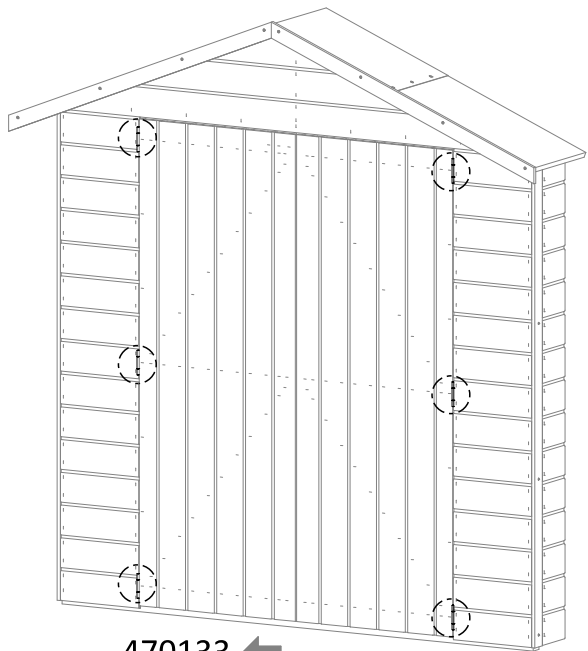

470133 ← 470134 →
596×1635/12mm 596×1635/12mm

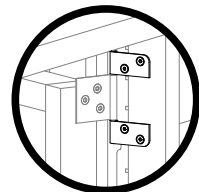
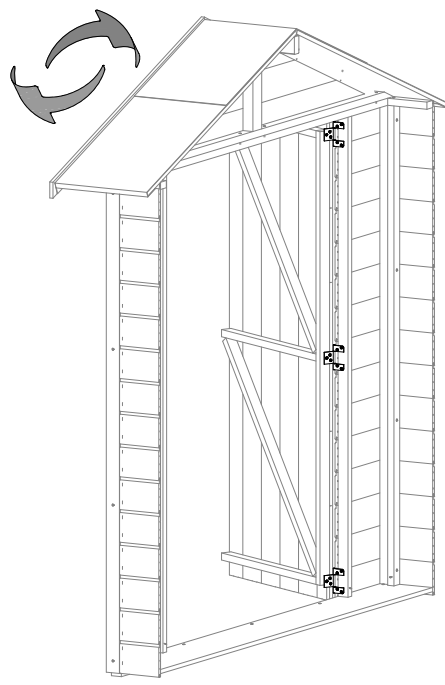
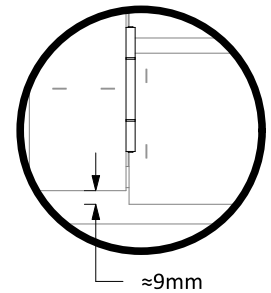
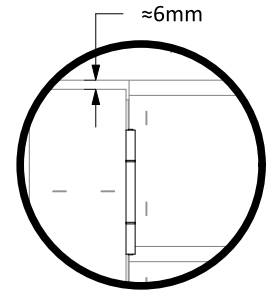

3012 : x4
ø3,5×25

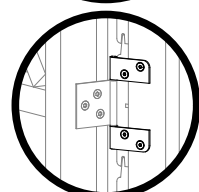

3012 : x4
ø3,5×25

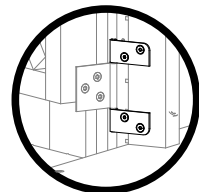

3012 : x4
ø3,5×25 x2

12

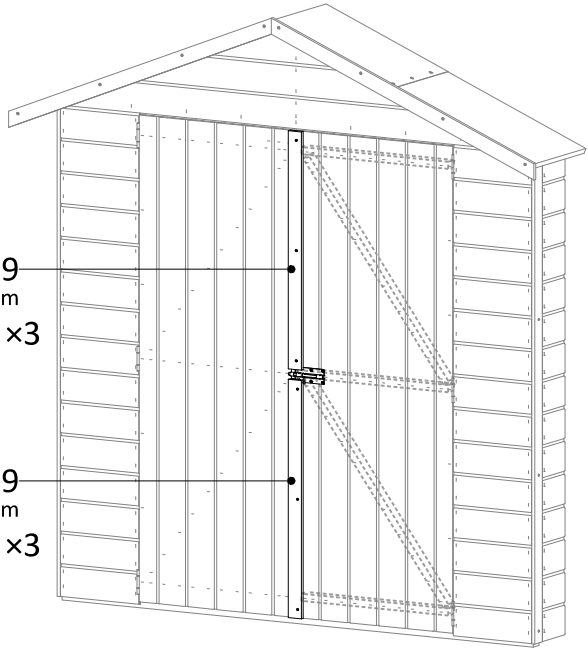

501659
12×50/800mm
+ 3012 : x3
ø3,5×25

501659
12×50/800mm
+ 3012 : x3
ø3,5×25

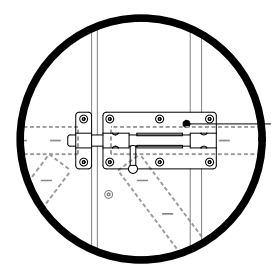

2155
+ 3009 : x8
ø3,5×12

13

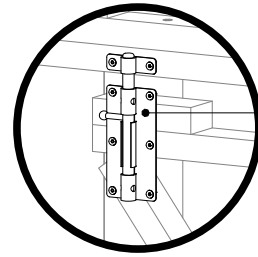
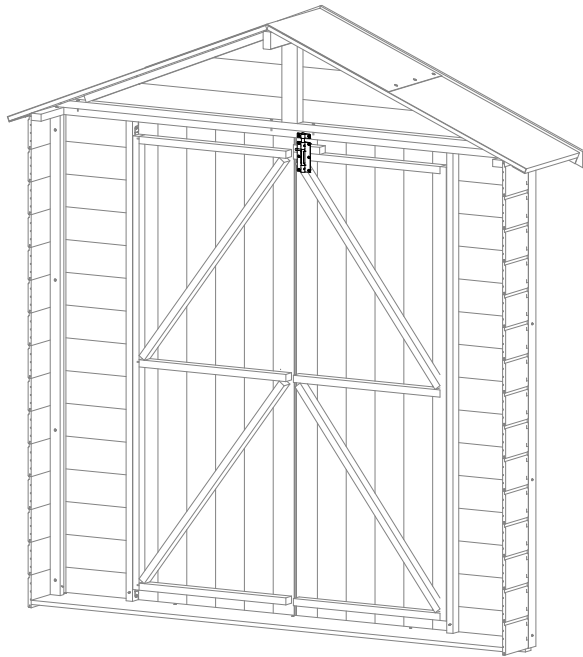

2155

+ 3009 : x8
ø3,5x12

14

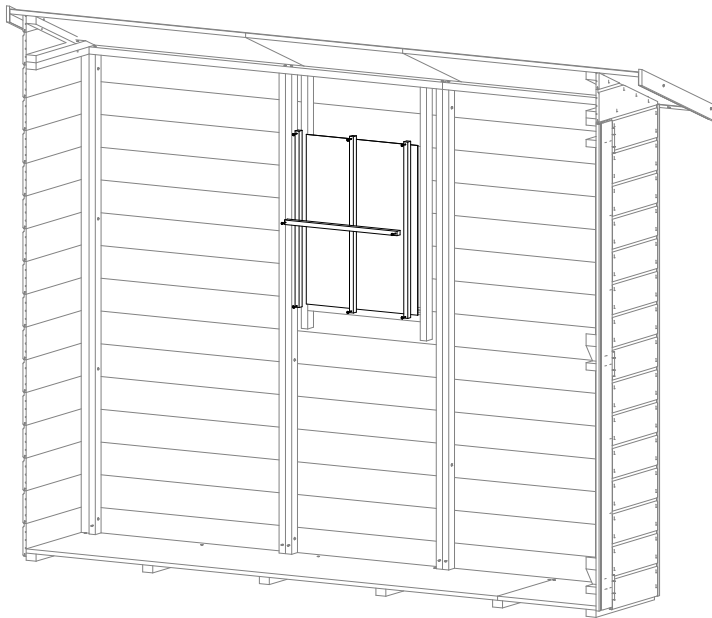

750010
425x570/1,2mm

50189
15x20/430mm

50957 : x3
15x20/592mm

3012 : x8
ø3,5x25

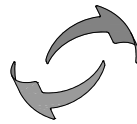
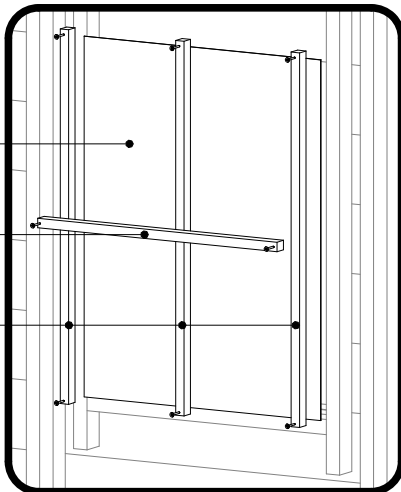

**Silicone
Silikon**

[EN] not included
[FR] non incluse
[NL] niet inbegrepen
[DE] nicht einbegriffen
[IT] non incluso
[ES] non incluida
[PT] não incluído
[GR] Δεν περιλαμβάνονται

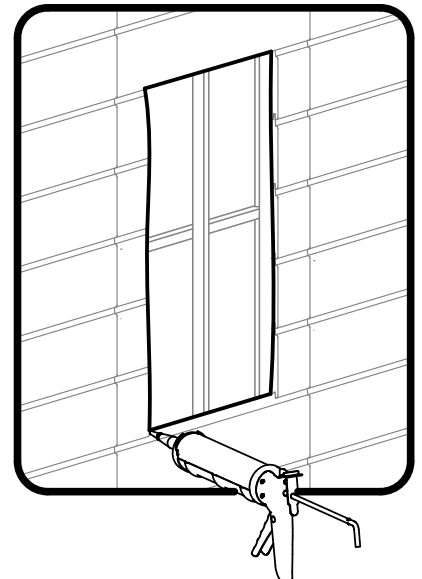

- (EN) **Unique warranty number, must be send for any request.**
- (FR) **Numéro de garantie unique, à transmettre obligatoirement pour toute demande.**
- (NL) **Uniek garantienummer, dat voor alle aanvragen moet worden verstrekt.**
- (DE) **Eindeutige Garantienummer, muss bei jeder Anfrage gesendet werden.**
- (IT) **Numero di garanzia unico, da trasmettere obbligatorio per ogni richiesta.**
- (ES) **Numero único de garantía, se transmitirá obligatoriamente para todas las solicitudes.**
- (PT) **Número de garantia único, será transmitido obrigatoriamente para todas as solicitações.**

