

Instrucciones de montaje  
Assembly instructions  
Instructions de montage  
Montageanleitung

**Pitarch**  
SYSTEM KIT MUEBLES



**REF. 6154**

SERVICIO POSTVENTA / SERVICE APRÈS VENTE  
AFTER SALES SERVICE / SERVICE NACH DEM VERKAUF

📞 652 851 032 (+34)964 321 111

8am-1pm 3pm-5:30pm Lunes a viernes  
Monday to Friday

Web: [www.mueblespitarch.com](http://www.mueblespitarch.com)  
e-mail: [postventa@mueblespitarch.com](mailto:postventa@mueblespitarch.com)

**LOTE/BATCH NUMBER**  
**5666**

Herramientas necesarias / Tools required / Outils nécessaires / Werkzeuge benötigt

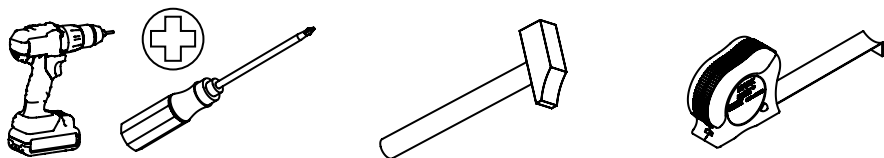

Herrajes incluidos / Fittings included / Matériel inclus / Hardware enthalten

Allen x 1

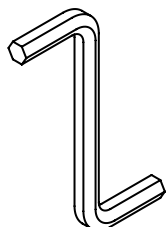

N°721034

Rei x 16



N°721020

Excgr x 14



N°721016

Per x 14

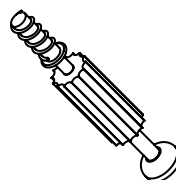

N°721017

Auto x 6

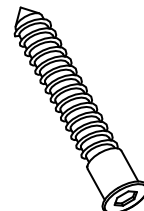

N°721002

Punt x 30

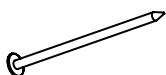

N°720006

Top x 1



N°721074

Tapex x 2

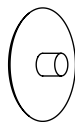

N°721091

Pat x 4

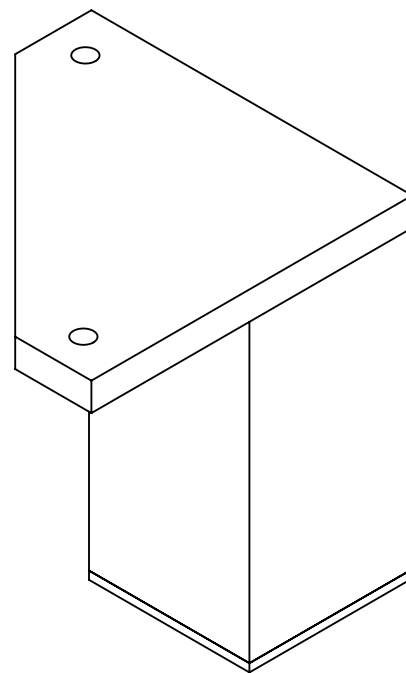

N°710234

Bss x 4

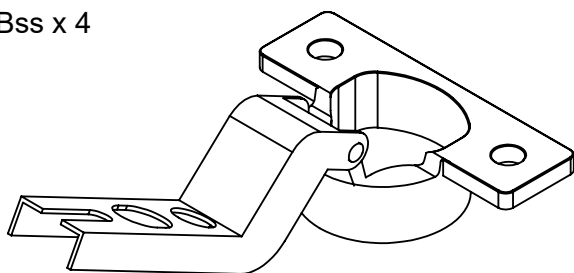

N°723024

Plb x 4

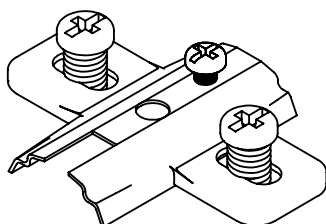

N°723014

PIEZAS / PARTS / PIÈCES / TEILE

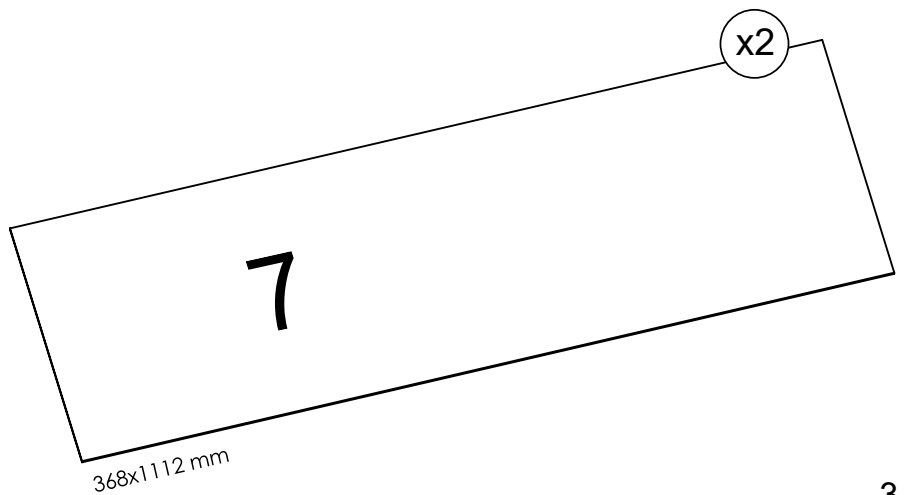
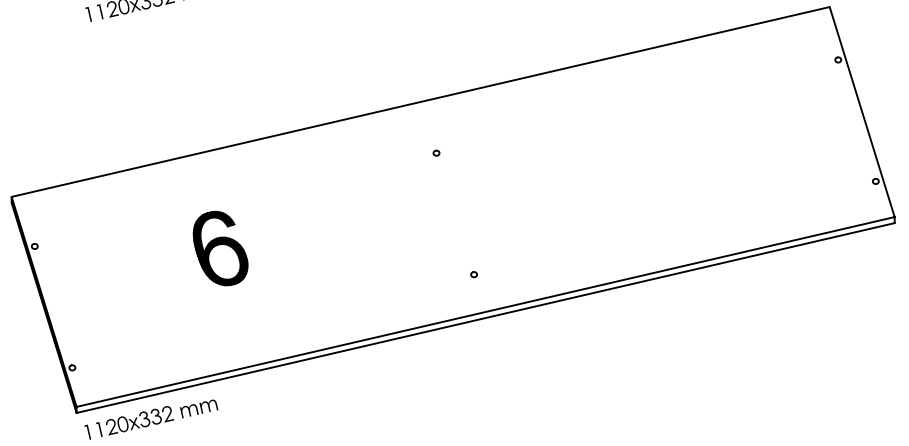
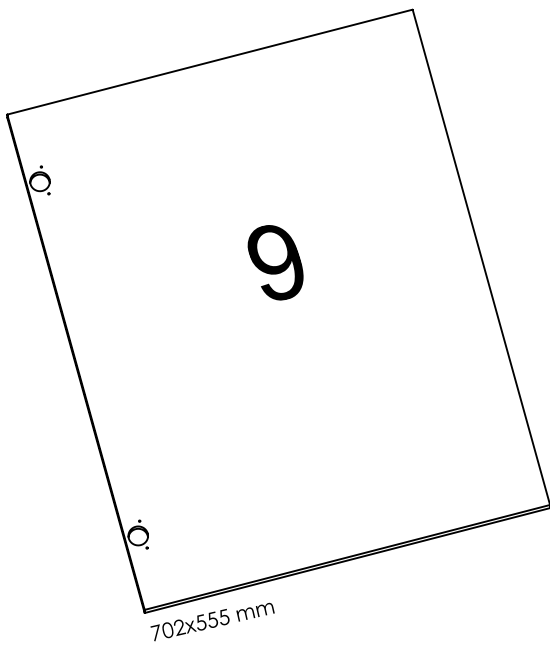
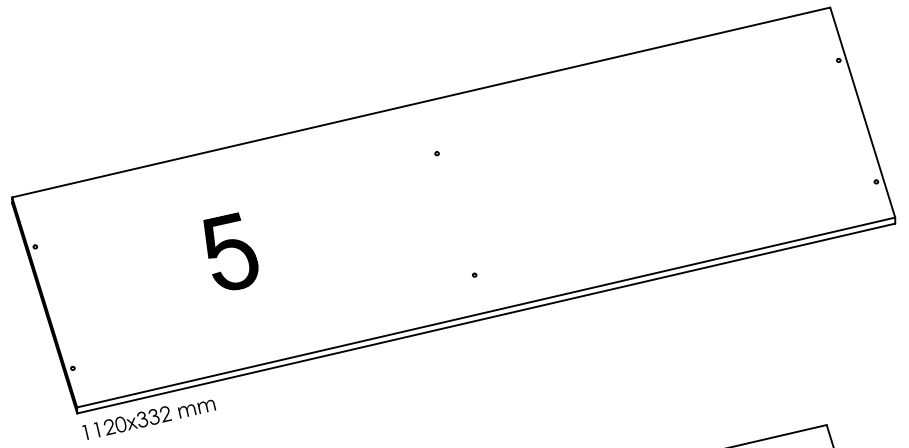
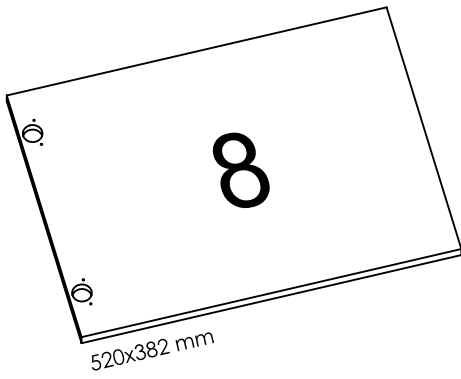
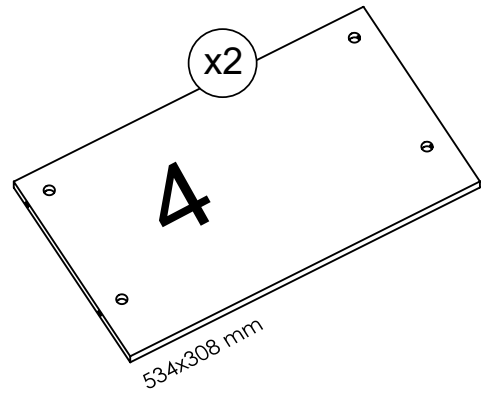
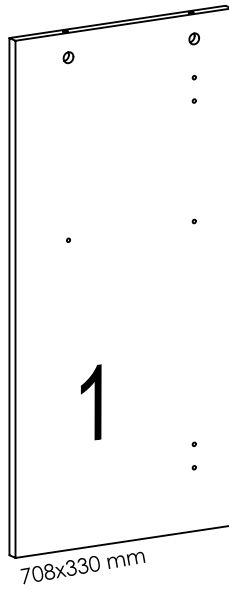
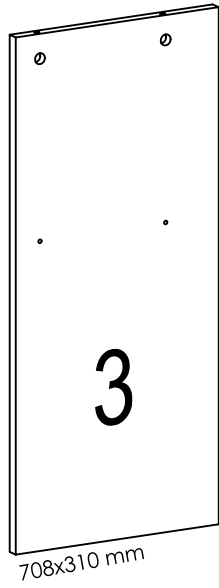
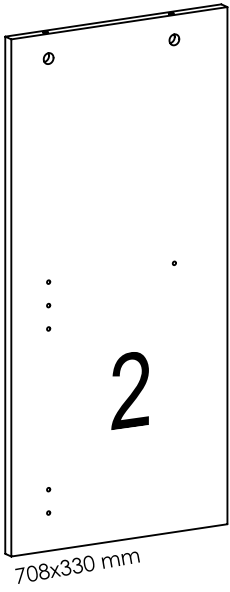

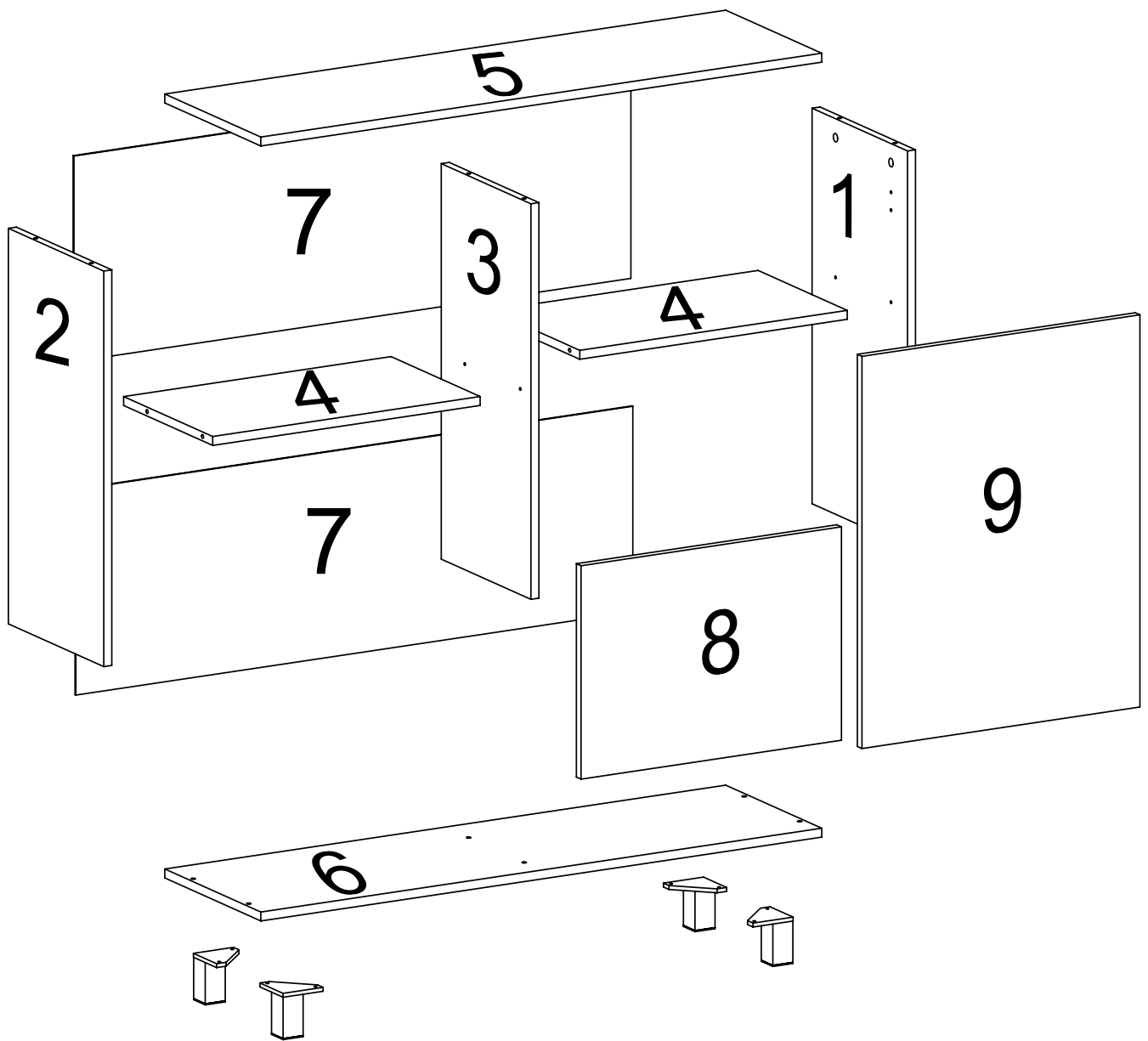

1 Per x 4

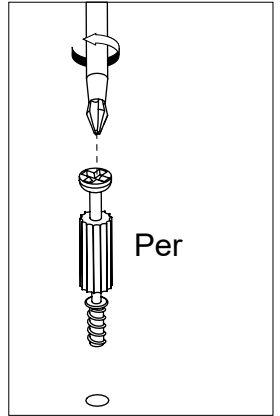
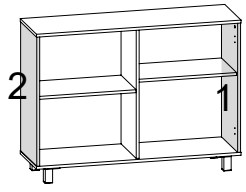
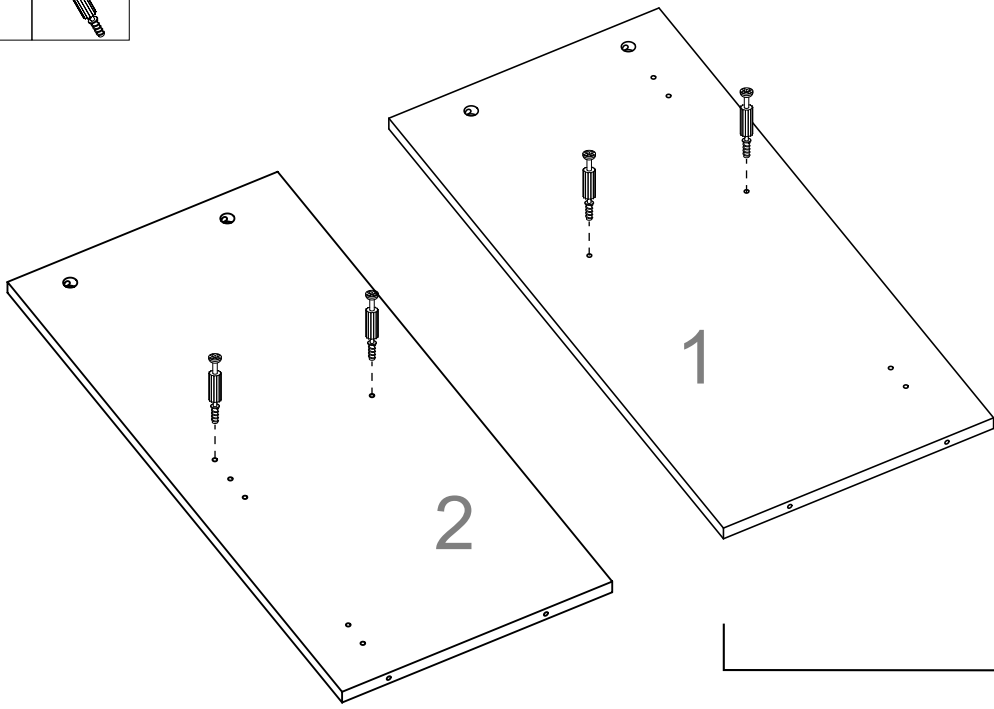

2 Plb x 4

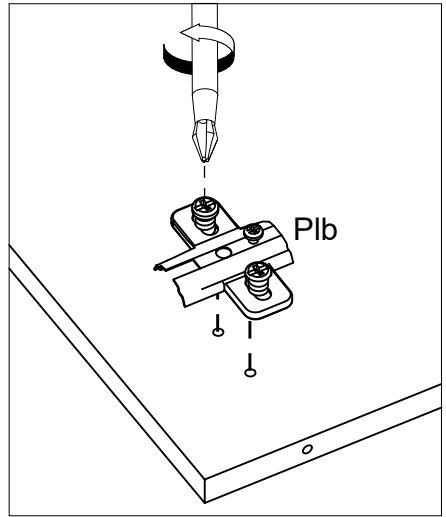
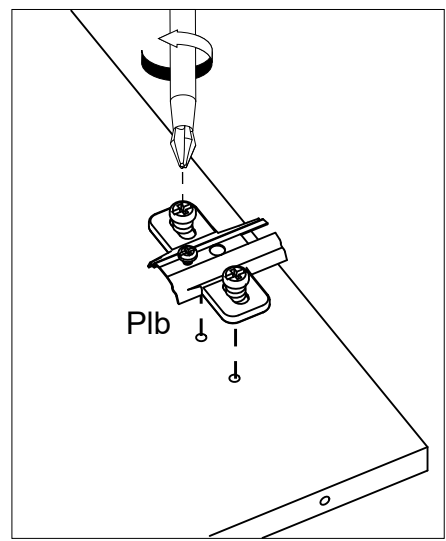
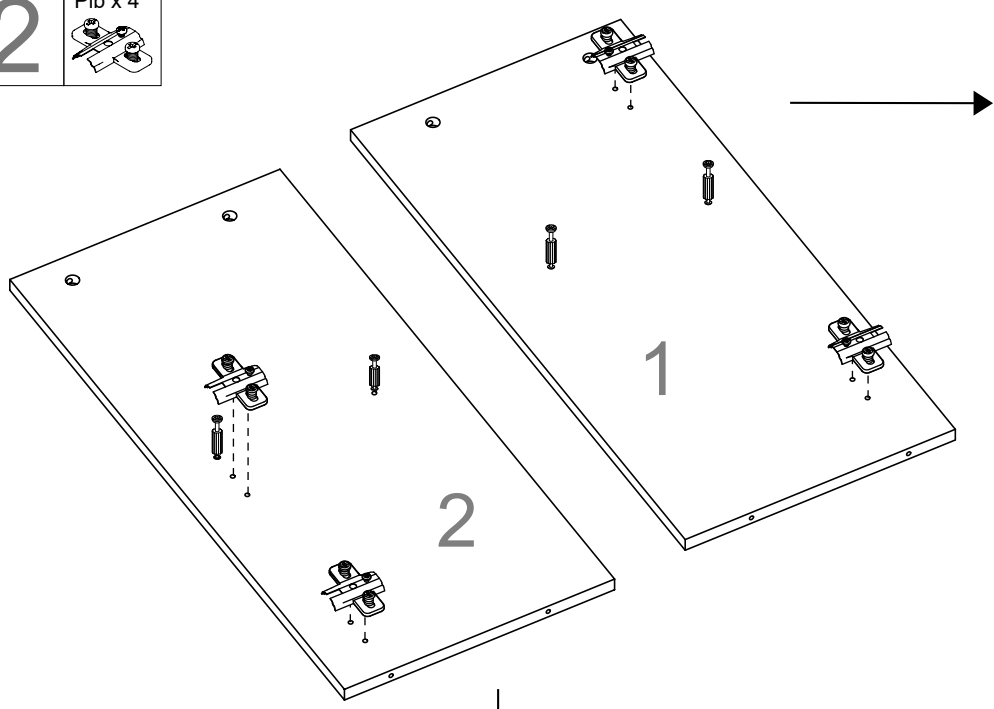

3 Per x 4

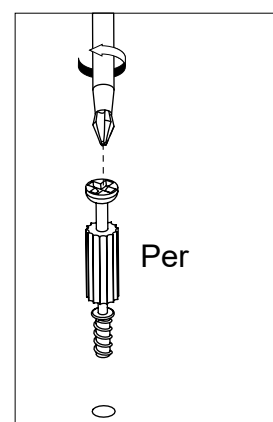
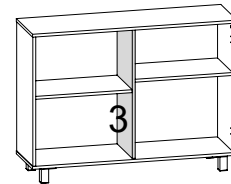
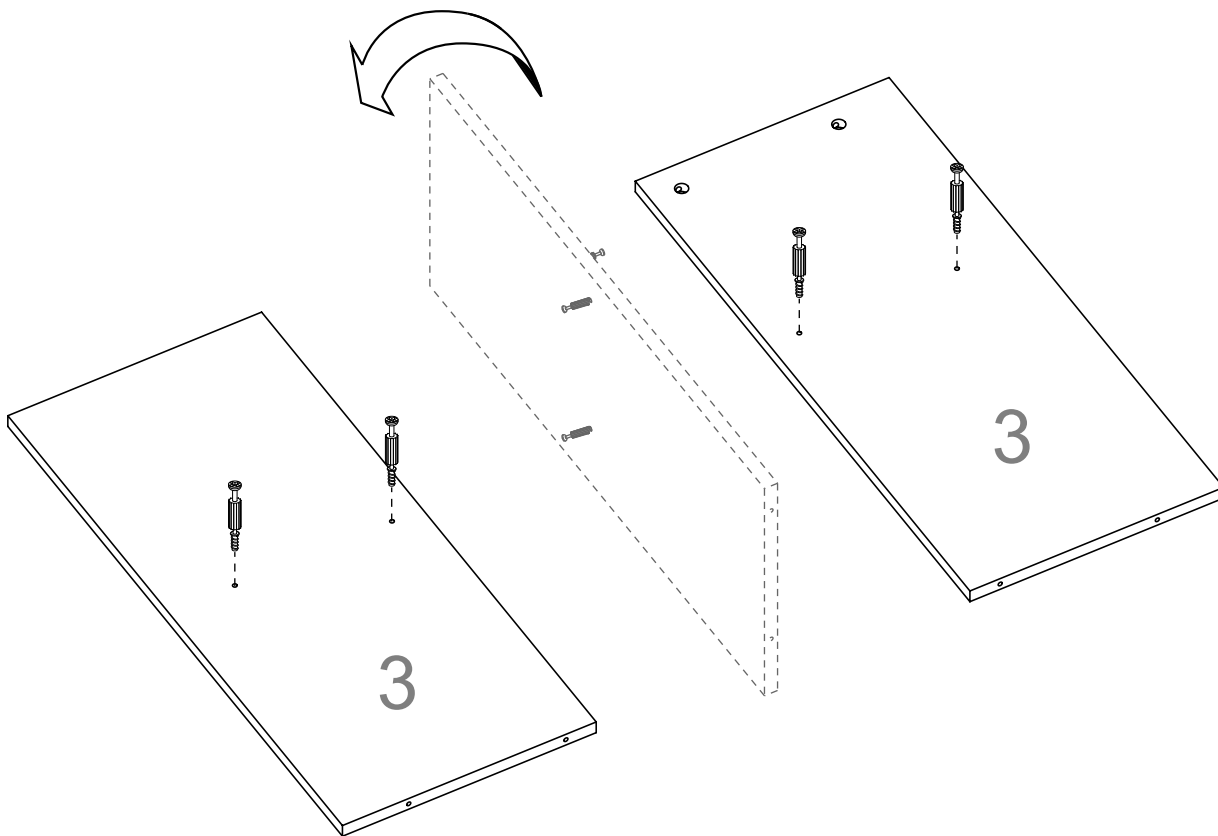

4

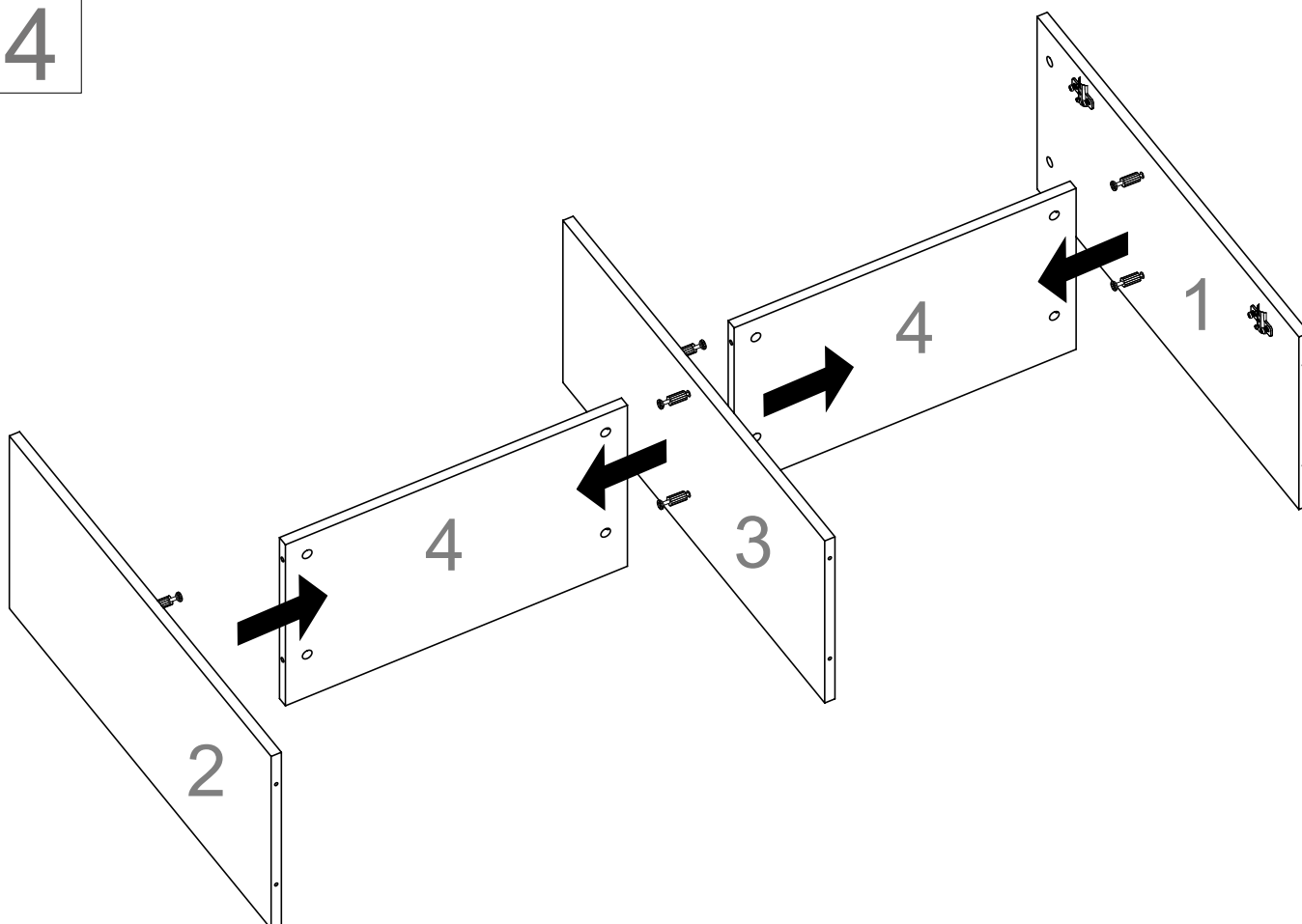

5 Excgr x 8

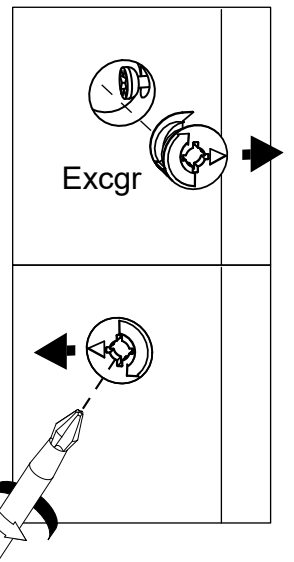
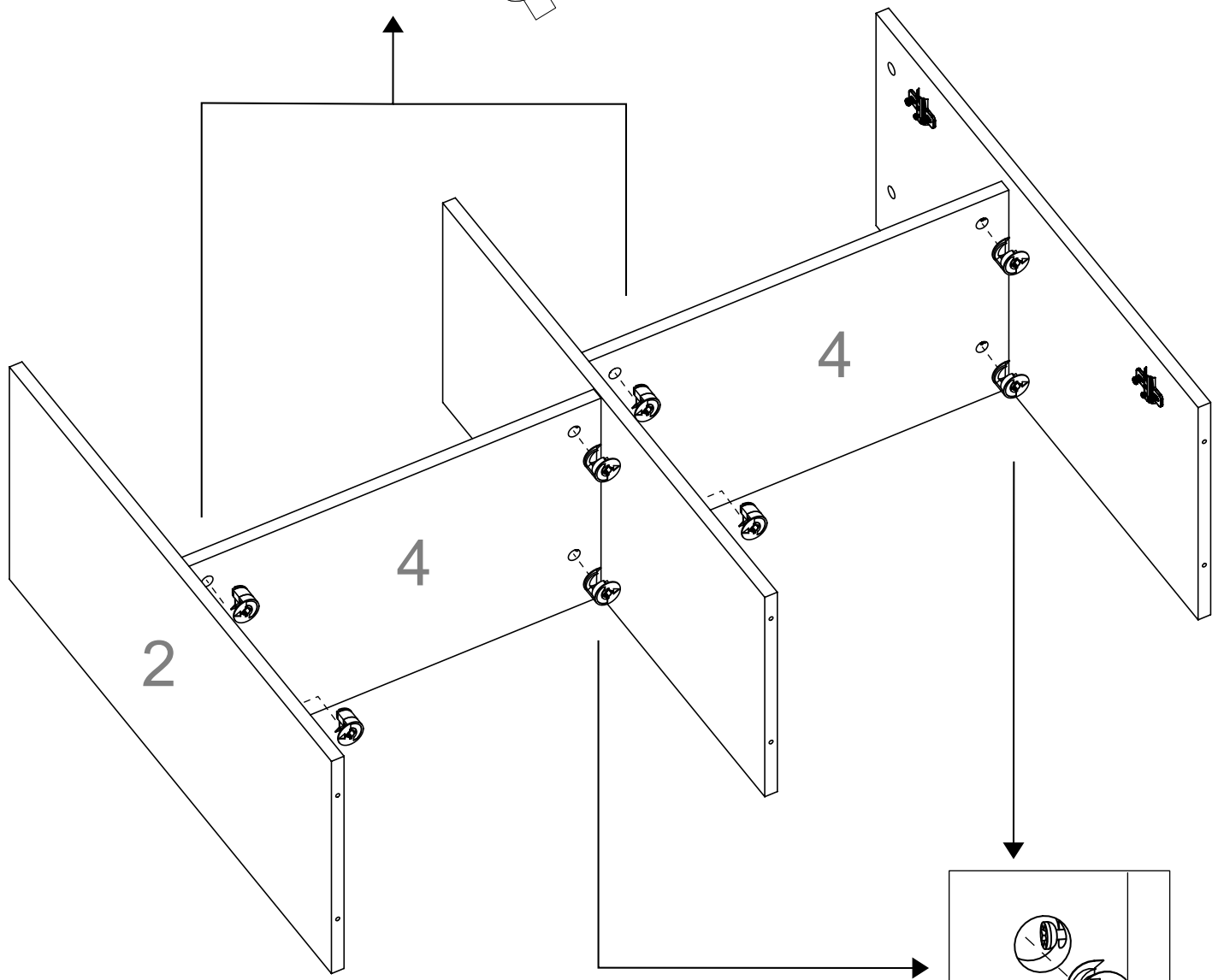
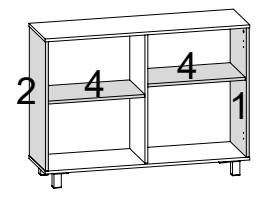
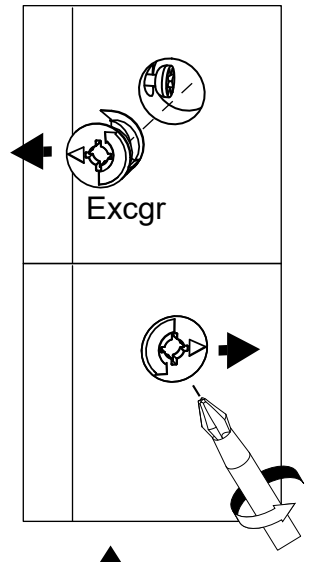

6 Per x 6

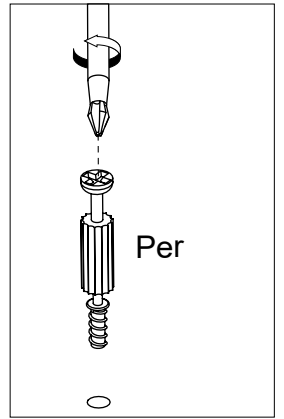
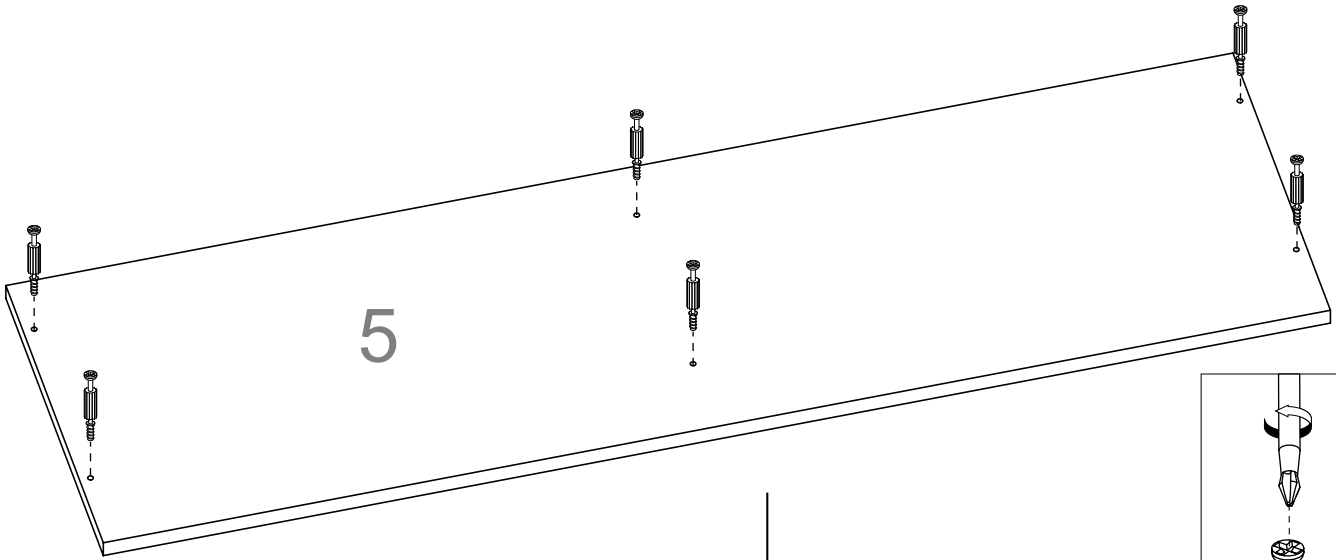
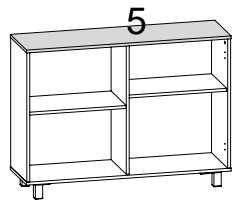

7

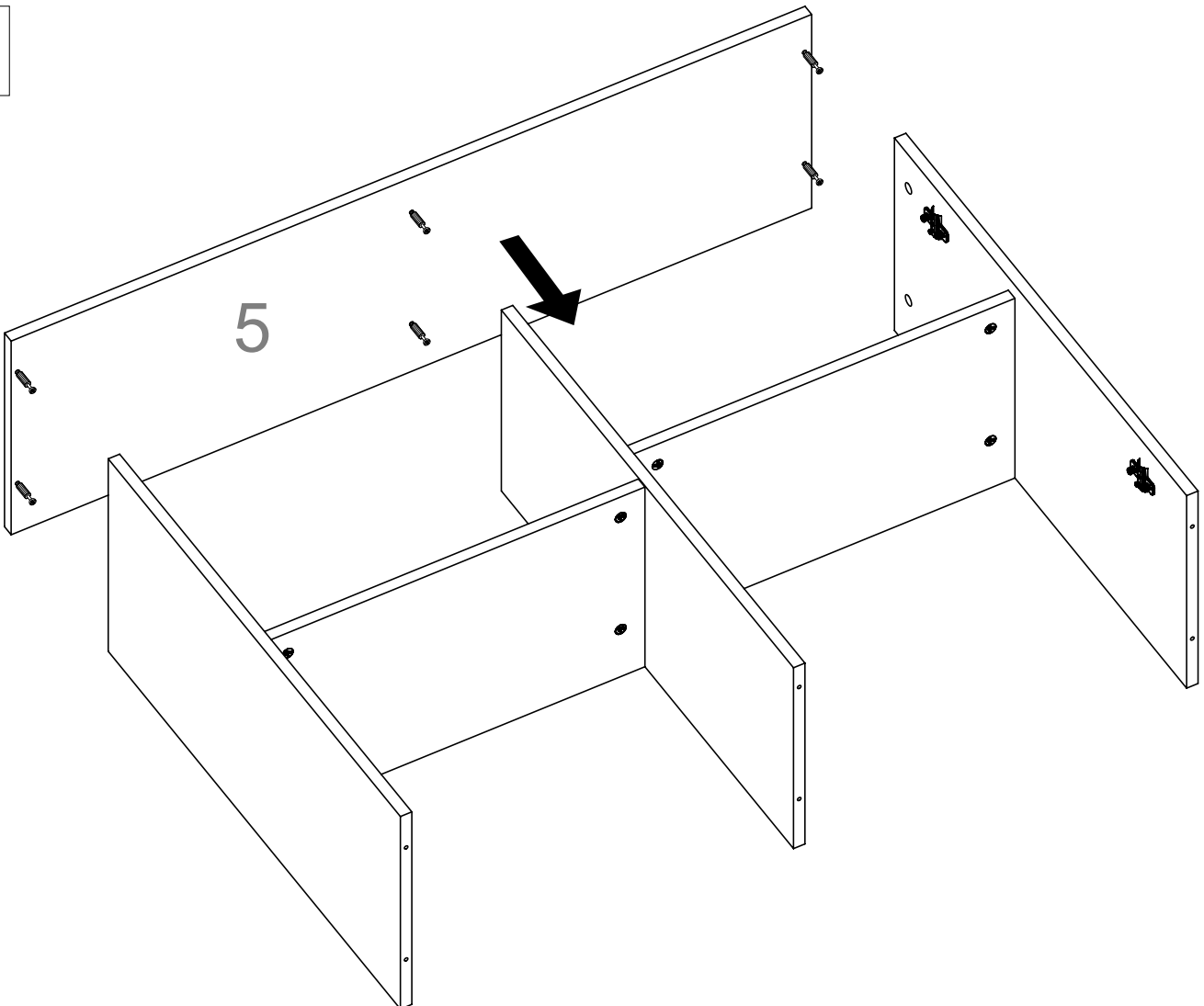



8 Excgr x 6

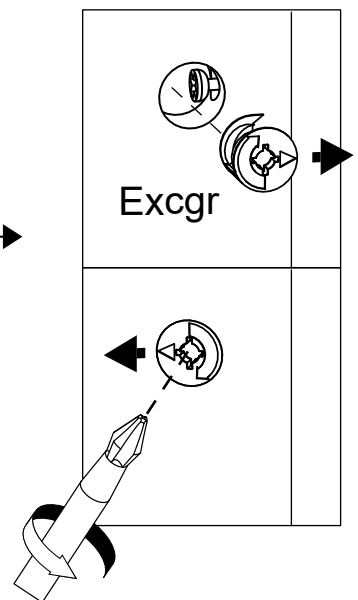
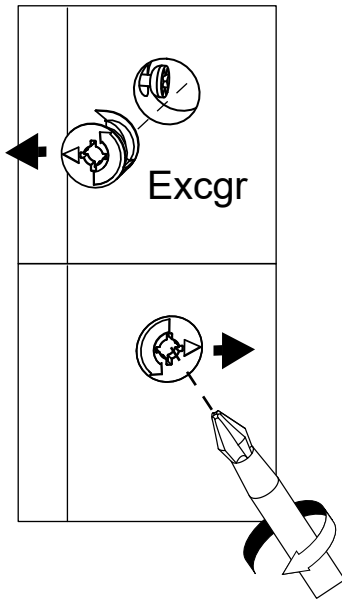
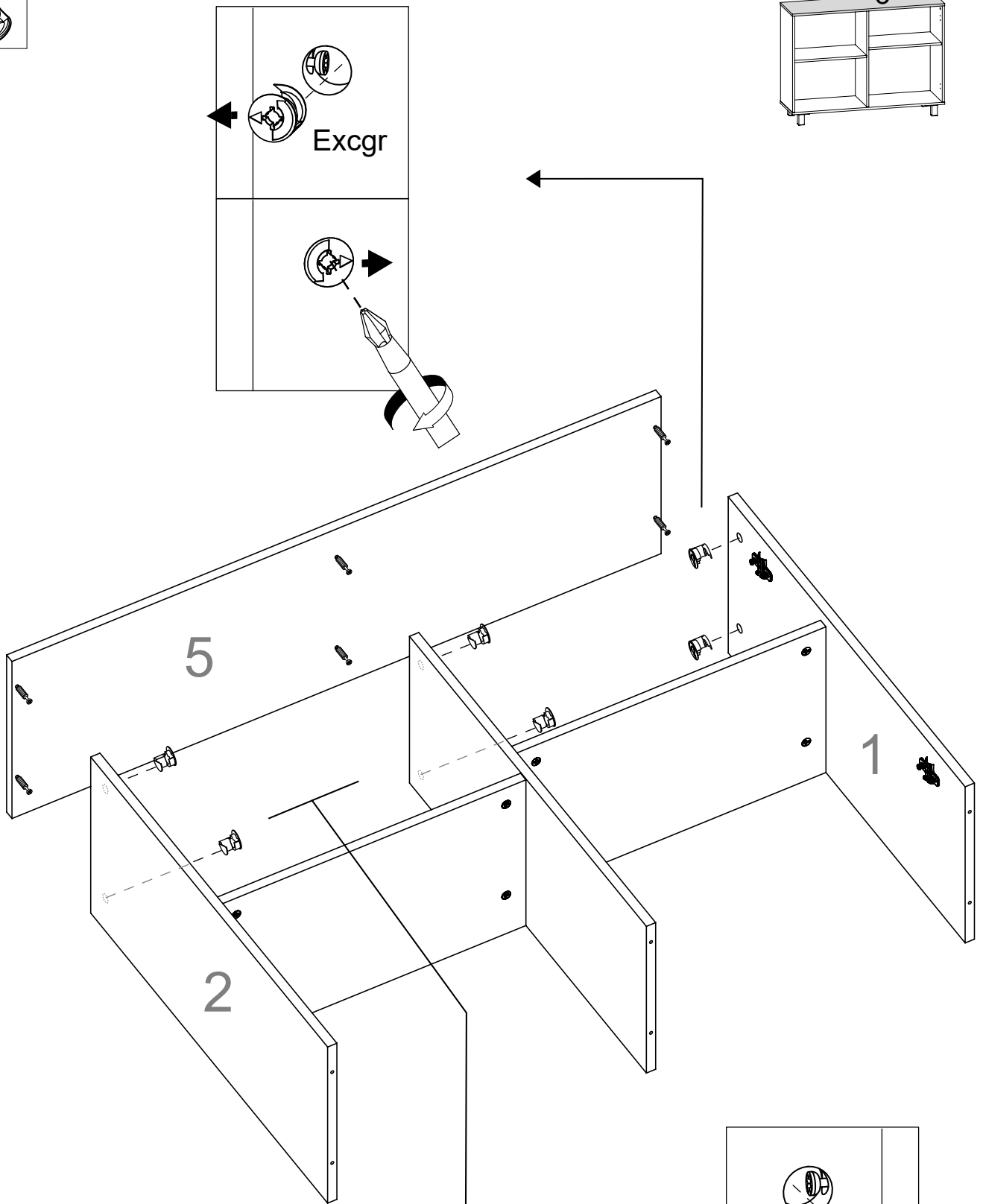
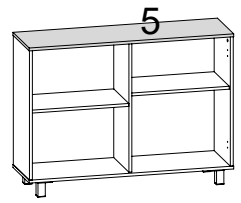

9 Auto x 6

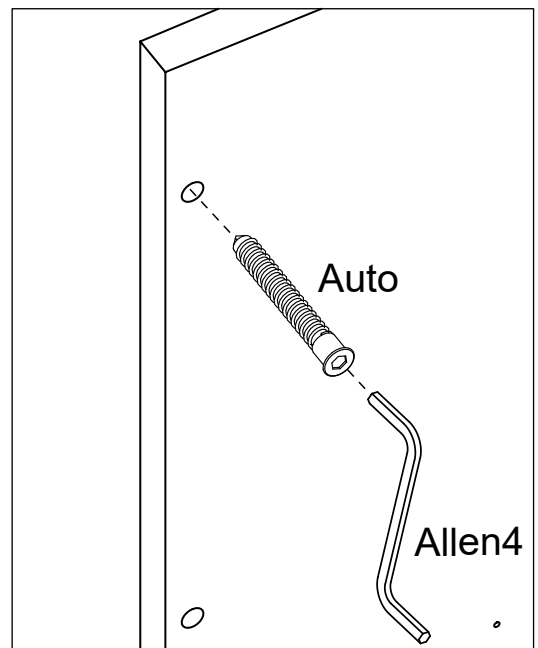
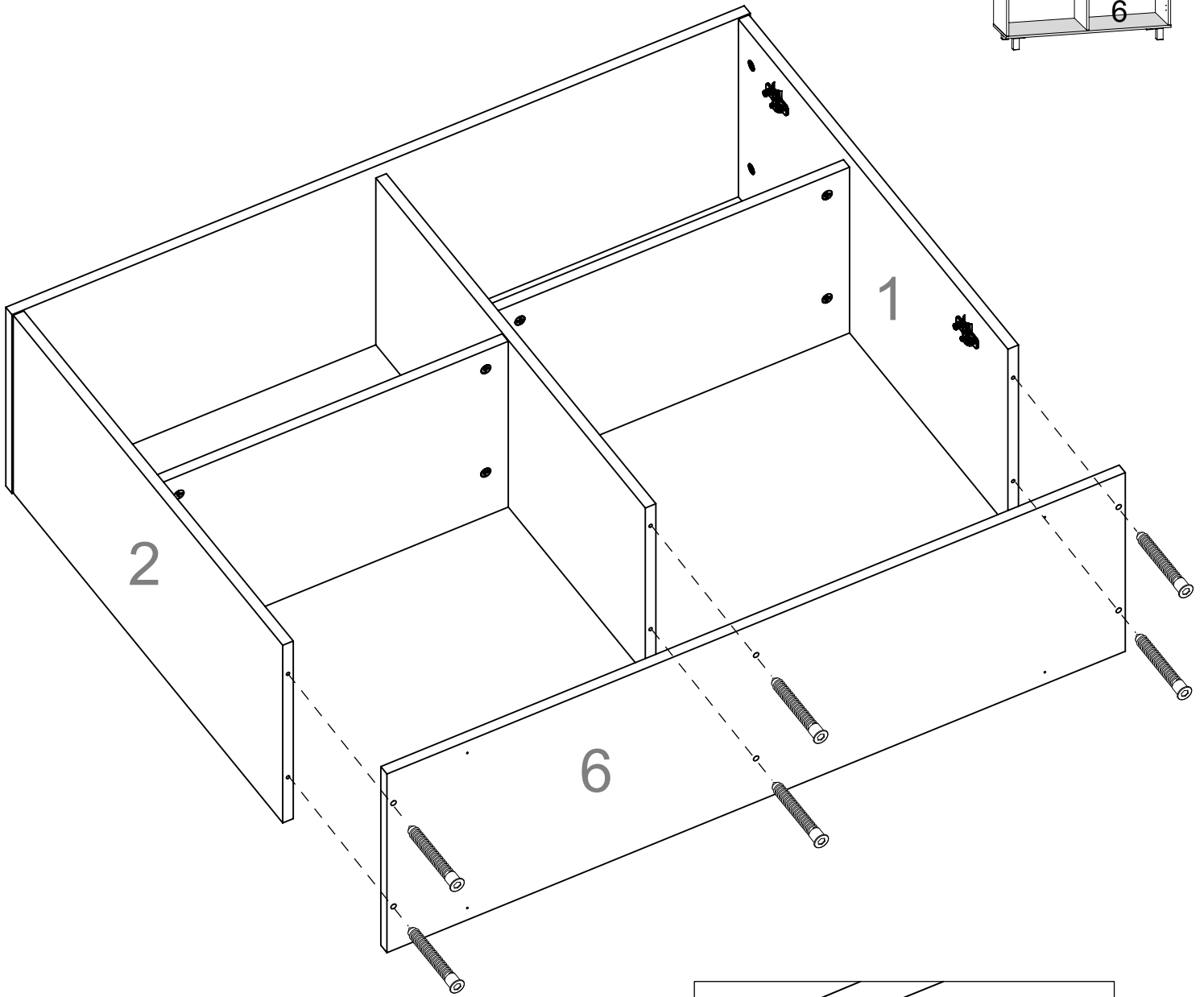
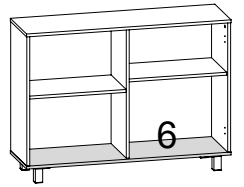

10    Rei x 8    Pat x 4

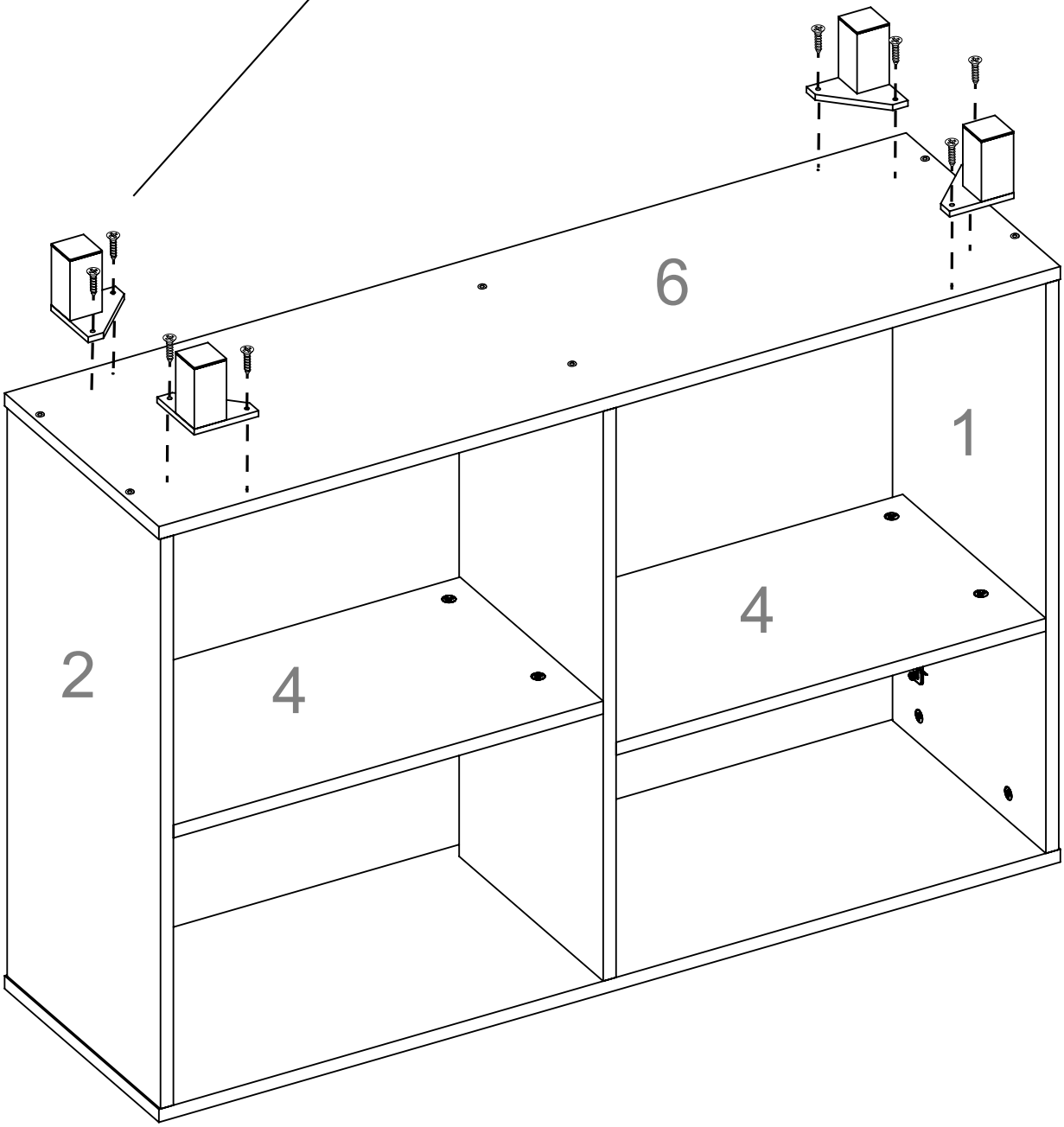
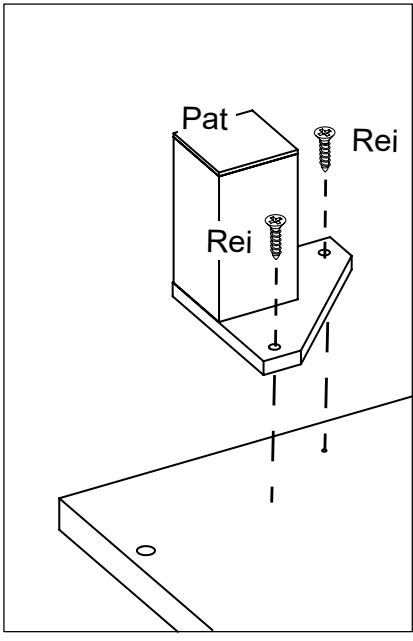
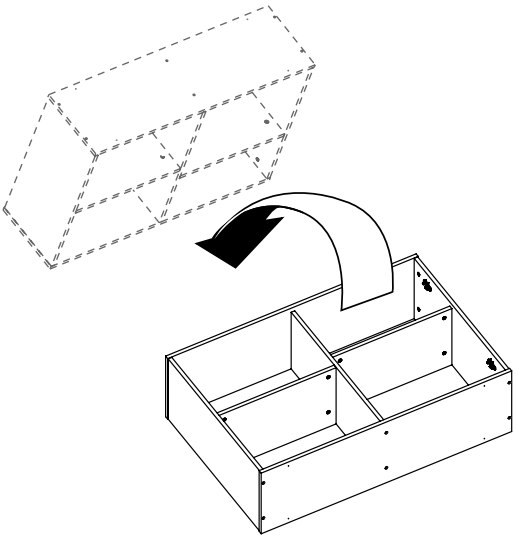

11

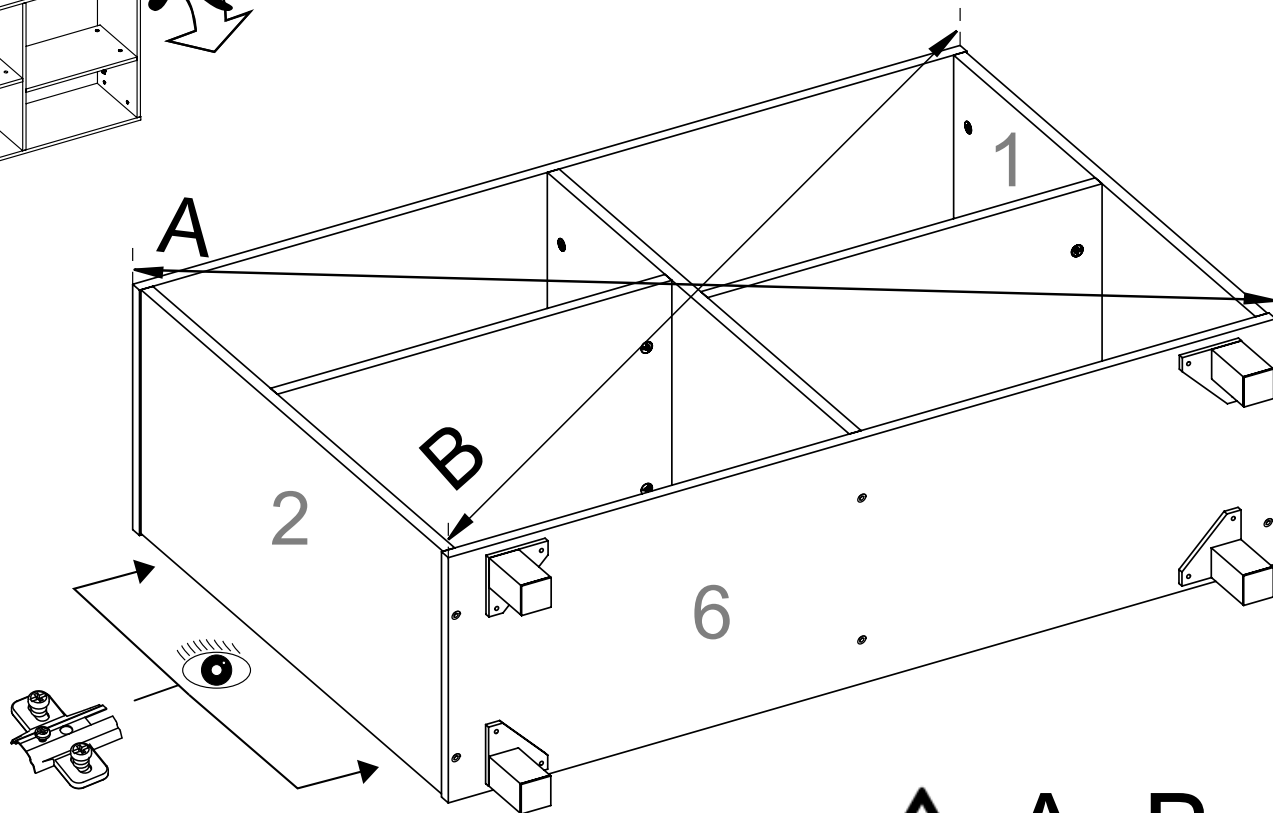
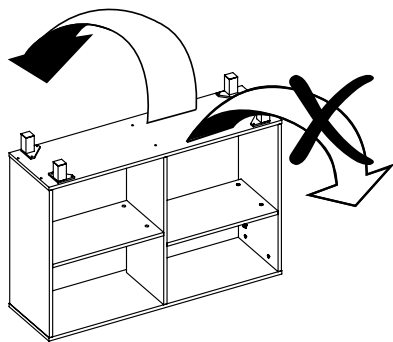
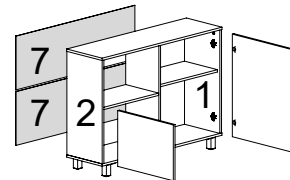

 **A=B**

12

Punt x 30

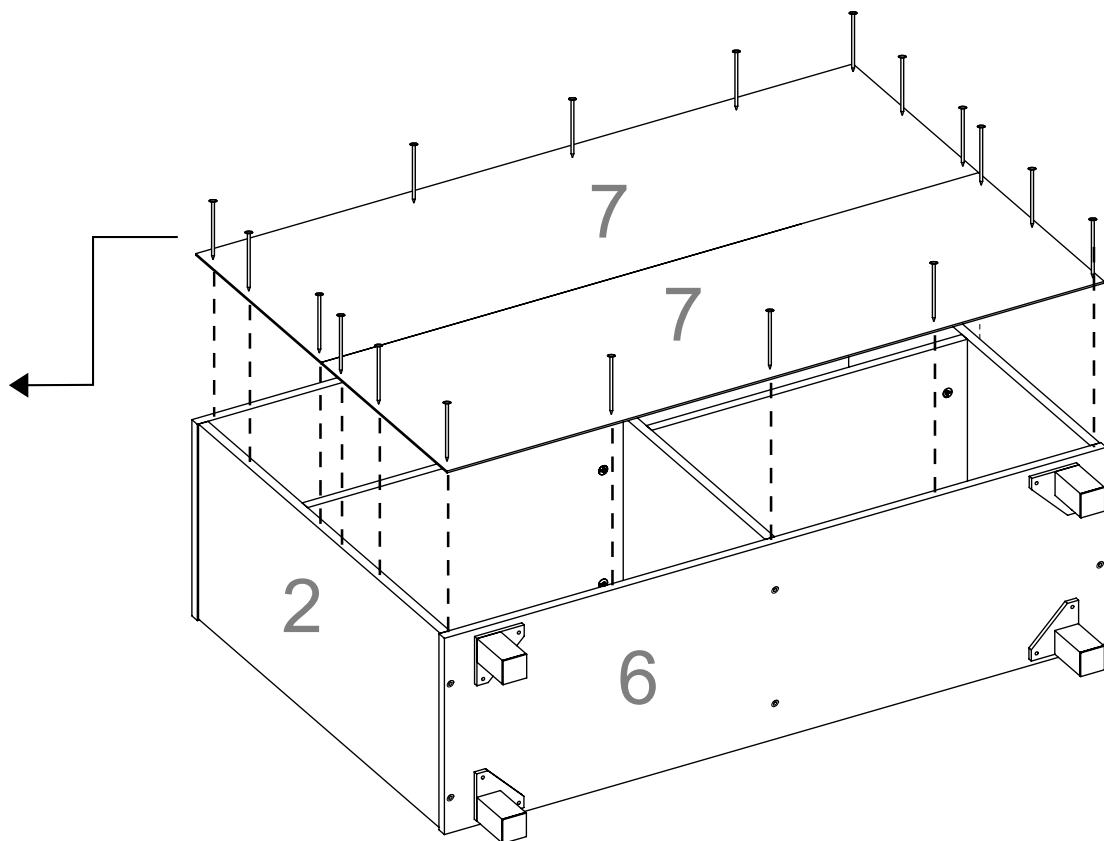
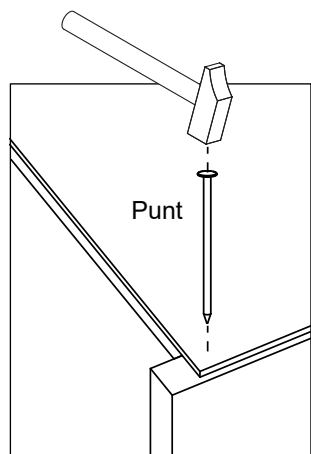
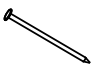

# 13

Rei x 8



Bss x 4

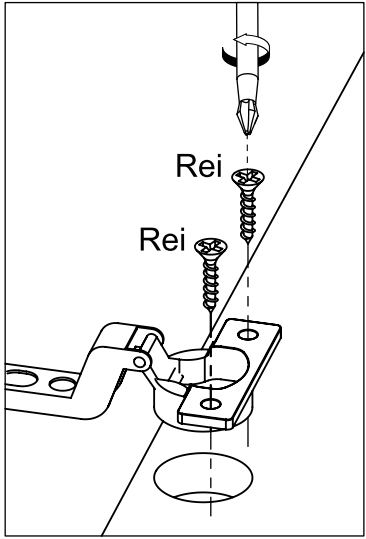
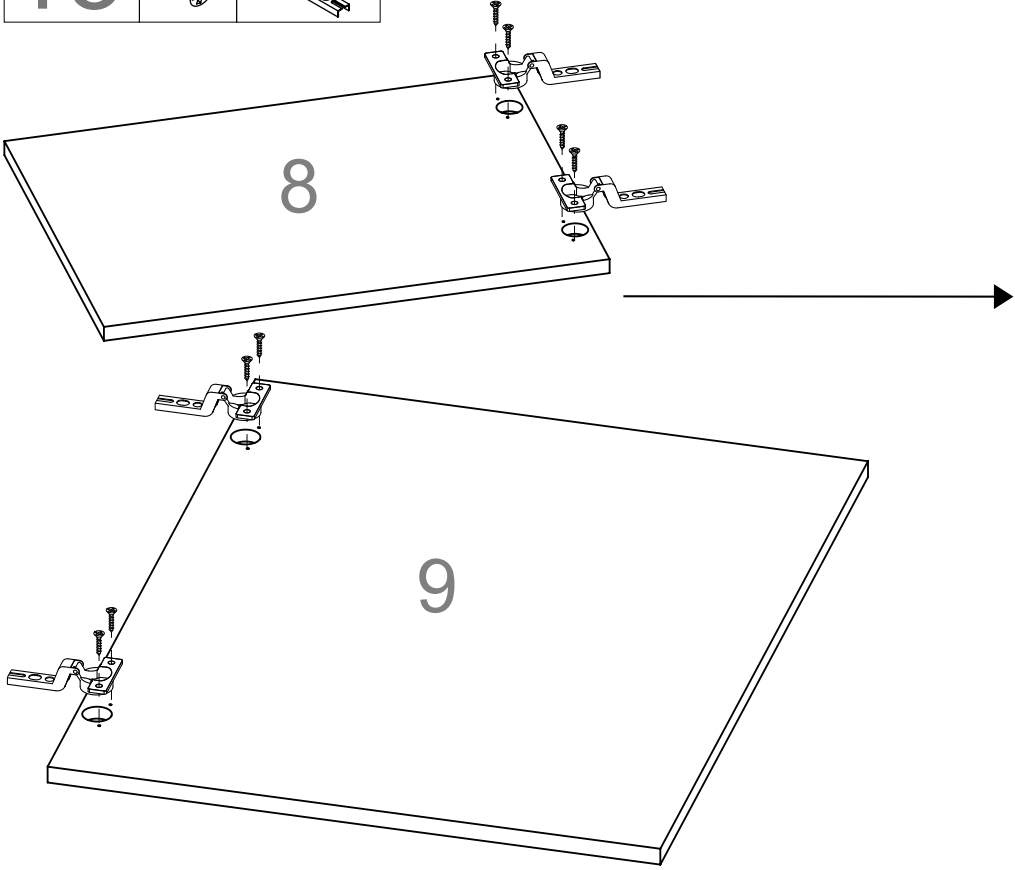
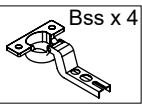

# 14

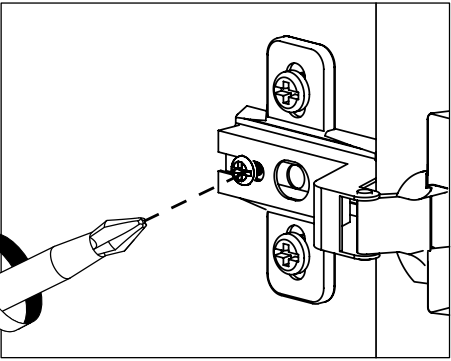
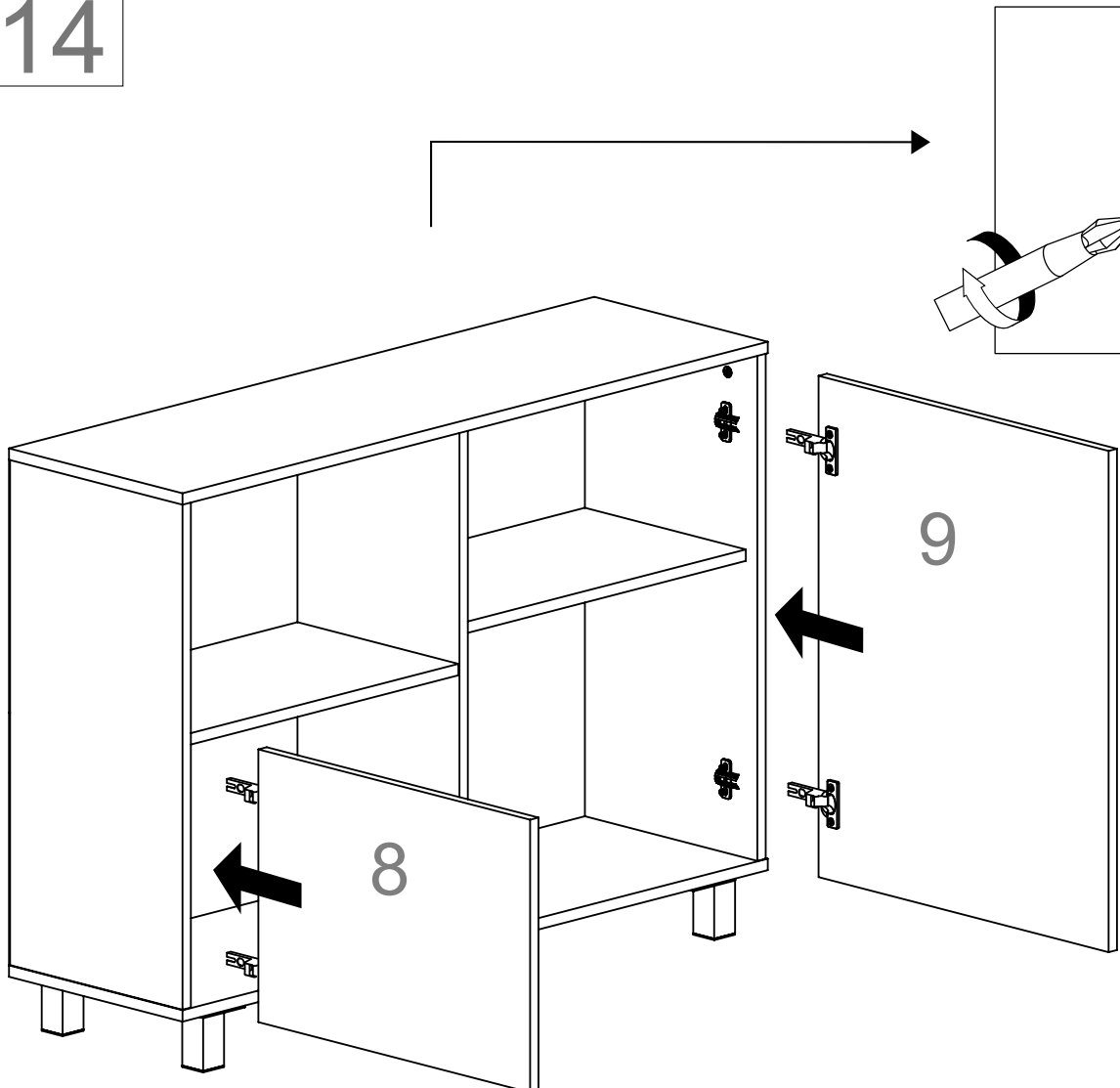

Error común  
Erreur commune  
Common mistake  
Häufiger Fehler

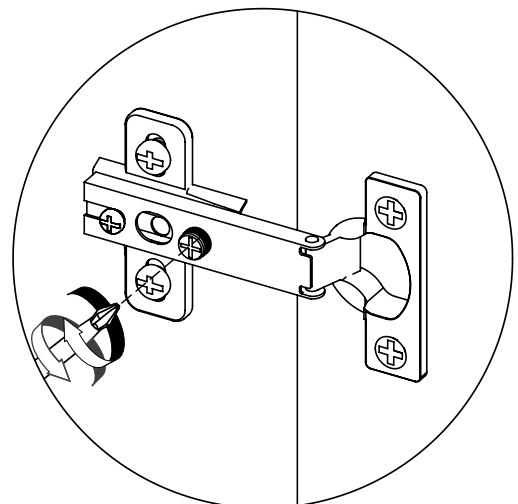
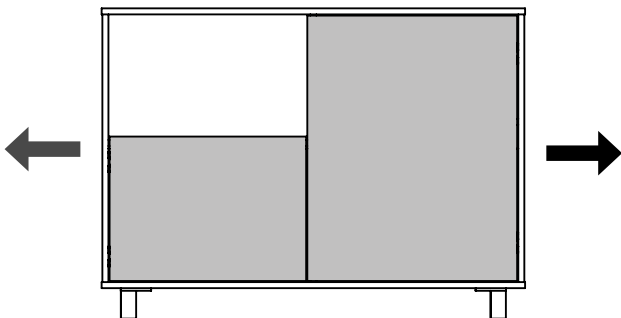
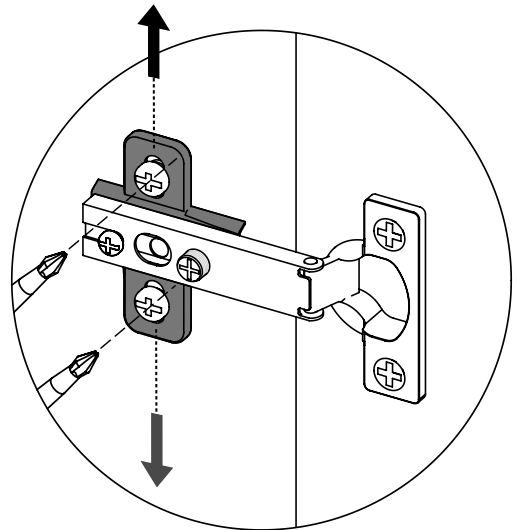
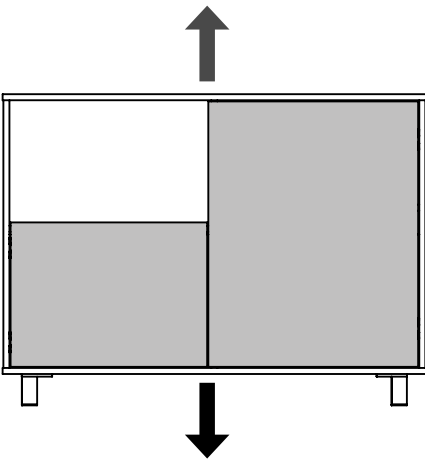
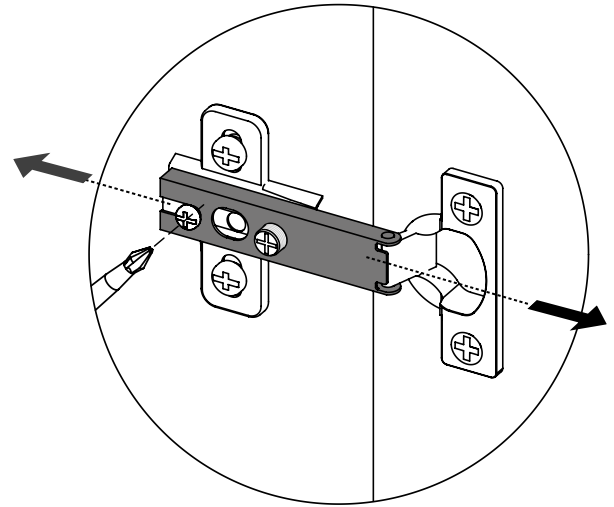
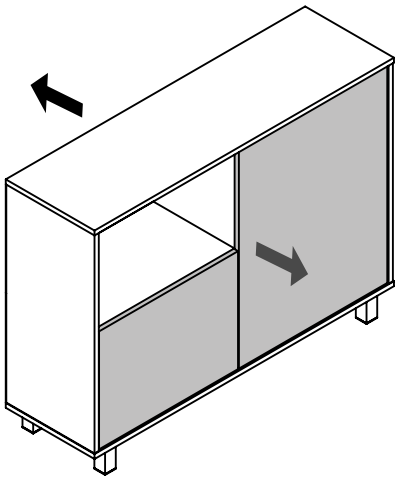

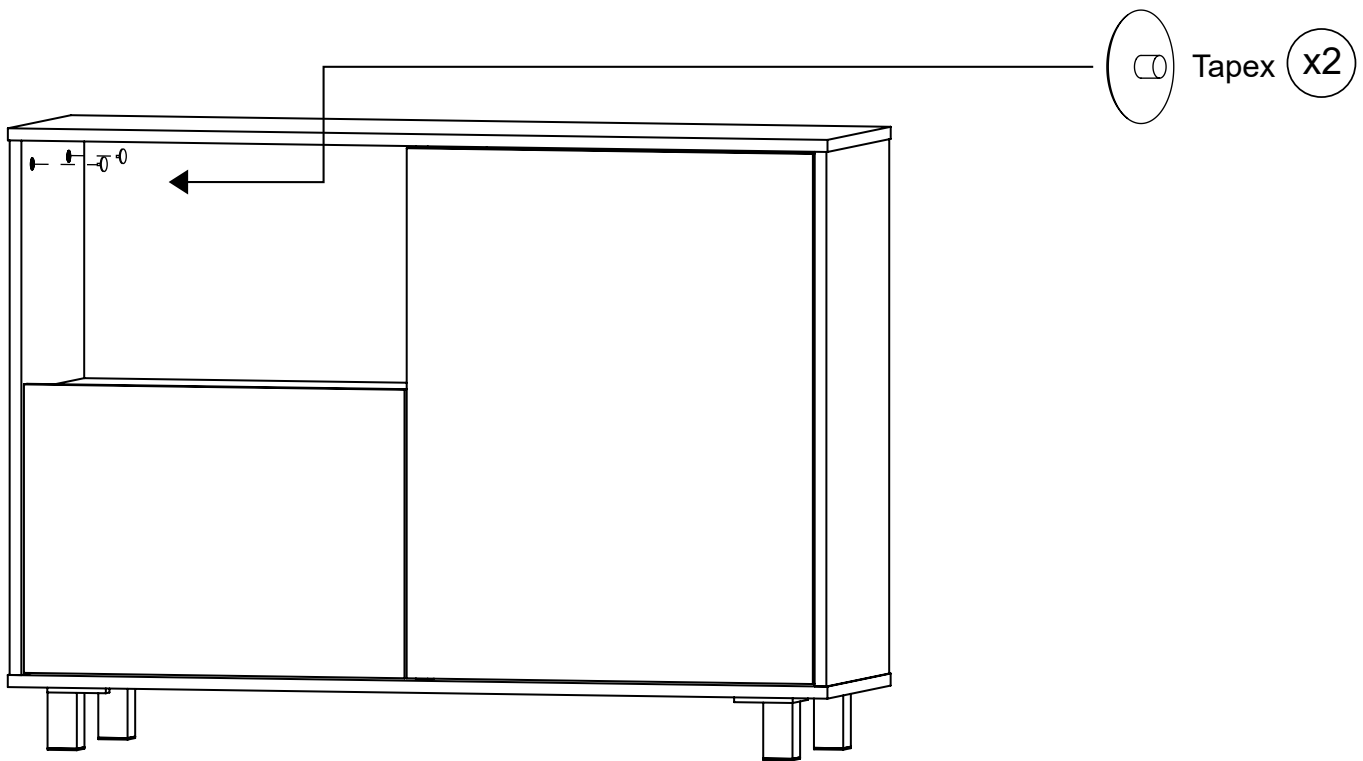

**Te aconsejamos/ We advise you / Nous vous recommandons / Wir beraten Sie**

**Ordena y cuenta las piezas y herrajes**

**Habilita una zona para el montaje**

**No fuerces los tornillos y los elementos de montaje**

**Sigue paso a paso las instrucciones de montaje**

**Order and count the parts and fittings**

**Enable an area for assembling.**

**Do not force the screws or assembly parts**

**Follow the assembly instructions step by step**

**Commander et compter les pièces et accessoires**

**Mettre en place un espace de rassemblement**

**N'utilisez pas de force sur les vis ou les éléments de montage**

**Suivre les instructions de montage étape par étape**

**Ordnen und zählen Sie die Teile und Armaturen**

**Einen Bereich für die Montage einrichten**

**Wenden Sie keine Gewalt auf Schrauben oder Befestigungselemente an.**

**Folgen Sie der schrittweisen Montageanleitung**

**CONDICIONES DE USO Y MANTENIMIENTO**

Producto de uso doméstico.

Evitar colocar el mueble cerca de fuentes de calor, de humedad o de una fuerte luz solar.

No lo limpie con productos abrasivos, ni disolventes.

Quitar el polvo antes de limpiarlo.

Utilizar un paño húmedo, limpio y sin pelos.

**LES CONDITIONS D'UTILISATION ET D'ENTRETIEN**

Produit à usage domestique.

Évitez de placer les meubles à proximité de sources de chaleur, d'humidité ou de forte lumière solaire.

Ne pas nettoyer avec des abrasifs ou des solvants.

Enlevez la poussière avant le nettoyage.

Utilisez un chiffon propre et humide.

**CONDITIONS OF USE AND MAINTENANCE OF FURNITURE**

Product for domestic use only.

Avoid placing the furniture near sources of heat, damp, or strong sunlight.

Do not clean with abrasive products or cleaning products with solvents.

Use a dust remover before any cleaning process.

It is recommended to use a damp, lint-free clean cloth.

**EINSATZ- UND WARTUNGSBEDINGUNGEN**

Produkt für den Hausgebrauch.

Vermeiden Sie die Aufstellung der Möbel in der Nähe von Wärmequellen, Feuchtigkeit oder starker Sonneneinstrahlung.

Reinigen Sie nicht mit Scheuermitteln oder Lösungsmitteln.

Entfernen Sie vor der Reinigung den Staub.

Verwenden Sie ein sauberes, feuchtes Tuch.