

KÖPPEN PLUS

7.86 m²



MANUAL DE INSTRUCCIONES · USER'S MANUAL · MANUAL DE INSTRUÇÕES
MANUEL D'INSTRUCTIONS · BENUTZERHANDBUCH · ΕΓΧΕΙΡΙΔΙΟ ΧΡΗΣΤΗ
PRIROČNIK Z NAVODILI ZA UPORABO · PRIRUČNIK ZA UPORABU



 **Hoggar**[®]

PRIRUČNIK ZA UPORABU

Našim cijenjenim klijentima:

**Hvala što ste odabrali
jedan od naših proizvoda**

Sadržaj kutije:



PRIJE NO ŠTO ZAPOČNETE...

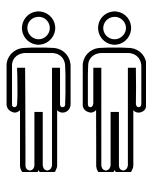

Za montažu
kućice
potrebne su
dvije osobe

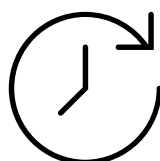

Montaža
može
potrajati 2
do 3 sata



Provjerite kod
nadležnih tijela
je li postavljanje
dopušteno

Savjetujemo vam da pažljivo, korak po korak slijedite ovaj priručnik za uporabu za ispravnu montažu proizvoda.

Provjerite imate li sve dijelove potrebne za montažu i uklonite zaštitnu plastiku prije no što počnete sa sastavljanjem.

Nemojte sastavljati kućicu/ormarić u blizini djece i/ili kućnih ljubimaca.

Planirajte postavljanje proizvoda na suh dan bez vjetra. Izbjegavajte montažu u dane s lošim vremenom kako biste izbjegli oštećenje proizvoda ili osobne ozljede. Kućica nije namijenjena za travnjak kao izravnu podlogu.

Preporučuje se montaža na čvrstoj, ravnoj drvenoj podlozi, ravnoj betonskoj podlozi ili podlozi od cementiranih opeka ili ploča. Vrlo je važno pričvrstiti kućicu za pod. Nisu uključeni vijci ni drugi dijelovi potrebni za pričvršćivanje.

Ako se radi betonska platforma, važno je da ona ima nagib prema rubovima kako bi se izbjegao prodor vode.

Proizvod treba smjestiti na mjestu zaštićenom od vjetra i s dobrom drenažom. Nastojte ga ne postavljati u neposrednoj blizini drveća, jer će biti potrebno redovito čišćenje grana i lišća koji bi mogli padati na njega.

Preporučujemo uklanjati snijeg s metalne kućice nakon svakog sniježenja, inače njegova težina može oštetiti krov kućice.

Nikada nemojte centrirati težinu tijela na krovu.

Za pravilno održavanje preporučuje se kućicu brisati mekom krpom te redovito čistiti vodilicu vrata kako bi pravilno klizila.

Kućice su namijenjene isključivo za čuvanje predmeta, stanovanje i druge namjene su zabranjene.

ČISTOĆA I ODRŽAVANJE



ČISTOĆA I ODRŽAVANJE

Za pravilno održavanje preporučuje se da proizvod održavate čistim, možete ga čistiti mekom vlažnom krpom.

Na proizvodu nikad nemojte koristiti abrazivne otopine ili deterdžente.

Važno je da krovni odvodni kućice uvijek budu čisti kako se na krovu ne bi skupljala prljavština.

JAMSTVO

Ova kućica izrađena je od materijala vrhunske kvalitete i pod strogim kontrolama i standardima kvalitete. U slučaju bilo kakvih mana na kupljenom proizvodu, obratite se službi za kupce na broj telefona i e-mail koji su navedeni na poledini ovog priručnika za uporabu.

Jamstvo vrijedi od datuma kupnje koji se nalazi na potvrdi ili računu koji je potrebno predložiti za korištenje jamstva.

Jamstveno razdoblje za ovaj proizvod je 10 godina za bilo kakve mane ili kvarove koji su rezultat strukturnog nedostatka ili promjene boje.









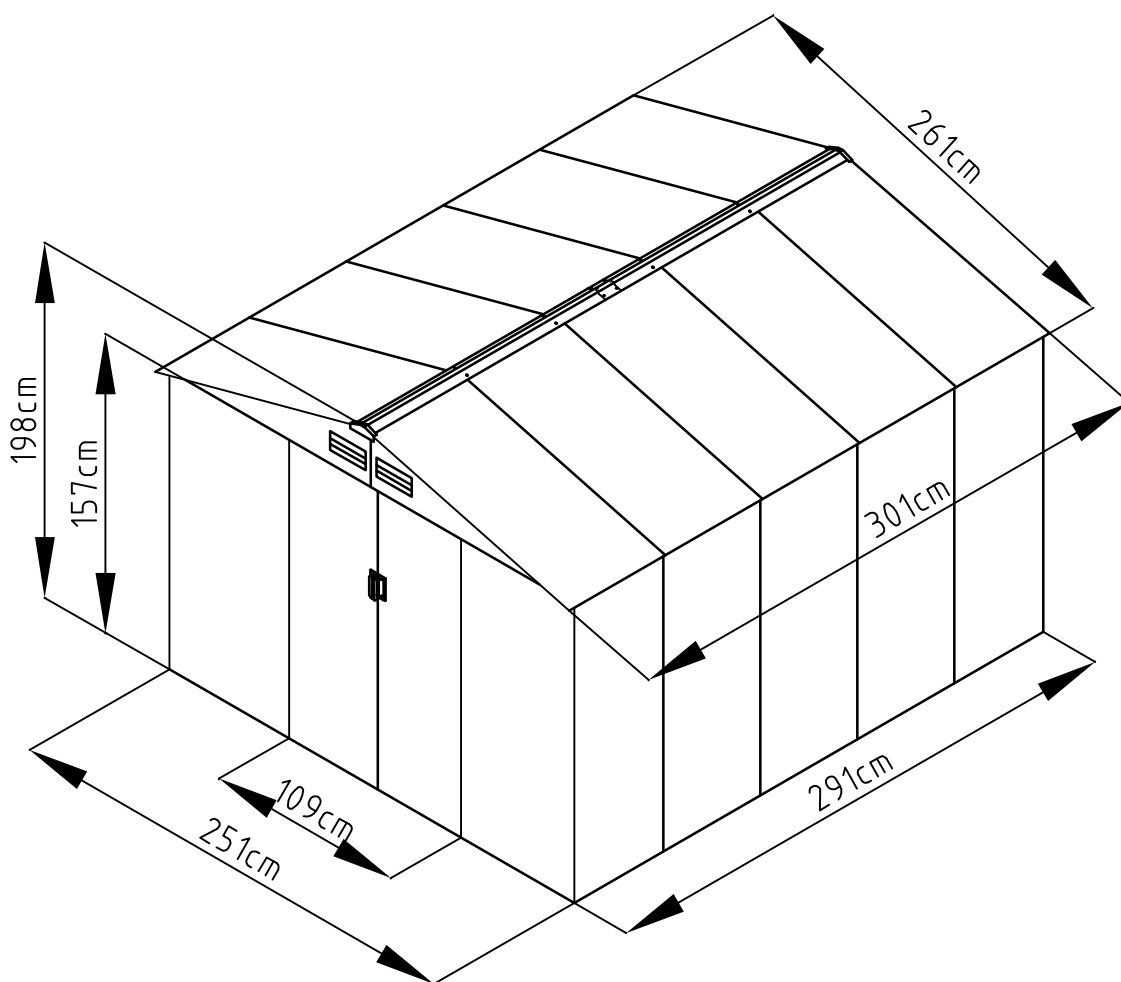























U JAMSTVO NISU UKLJUČENI:

- › Neadekvatan transport. Nakon primitka proizvoda morate obavijestiti agenciju za prijevoz u roku navedenom na dostavnici.
- › Lomovi, štete uzrokovane vremenskim nepogodama kao što su jaki vjetrovi, tuča, poplave itd.
- › Loša montaža, nepravilna uporaba i njihove posljedice.
- › Neodržavanje i dijelovi koji se troše kao što su amortizeri, cilindar, kvaka i šarke.
- › Plastični dijelovi.
- › Čišćenje ili održavanje abrazivnim proizvodima.
- › Mjestimična oštećenja od korozije na dijelovima ili limovima te područja oštećena neizravnim putem poput oštećenja zbog izloženosti morskoj soli koja uzrokuje koroziju. Oštećenja od korozije na rubovima ili kutovima dijelova isključena su iz jamstva.
- › Promjena boje uzrokovana protokom vremena.
- › Ogrebotine na boji.
- › Udarci ili udubljenja u limu.
- › Nepredložene računa ili potvrde o prodaji i neobavješćavanje na vrijeme i na odgovarajući način.
- › Troškovi nastali rukovanjem neispravnim ili oštećenim dijelovima, kao i odgovornost za neizravne štete koje tako mogu nastati.
- › Uporaba u komercijalne ili druge svrhe osim osobnih ili kućnih.
- › Preinake, bojenje ili montaža koji nisu izvršeni u skladu s odrednicama jamstva i objašnjenjima u priručniku za uporabu, kao i štete uzrokovane prekoračenjem kapaciteta skladištenja proizvoda.

MONTAJE

Assembly · Montagem · Montage · Συναρμολόγηση · Montaż

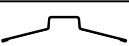

NO.	IMAGE	mm	QTY	NO.	IMAGE	mm	QTY
UNDER				T-B30		1595	x1
T-B1		1302	x2	T-B35		1595	x1
T-F3		1502	x4	T-31		1535	x2
T-B4		760	x1	T-B32		890	x4
T-B5		760	x1	T-B33		551	x1
T-B6		1095	x1	T-B34		551	x1
MIDDLE				T-B36		551	x1
T-B7		1600	x2	T-B37		551	x1
T-8		1600	x4	ANNEX			
T-14		1600	x10	T-P1			x4
T-B9		1232	x1	T-P2			x4
T-B10		1232	x1	T-P3			x4
T-F11		1498	x2	T-P4			x2
T-F13		1498	x2	TP5A			x4
T-B12		1390	x1	T-P6			x2
T-B15		1180	x1	T-P7		200	x1
T-16		1595	x1	T-P8			x2
T-17		1595	x1	T-G40			x263
T-B18		1240	x1	T-G41		ST4x10	x312
TOP 1				T-G42		ST4x16	x26
T-B19		1232.6	x2	T-G43		M4x10	x87
T-B20		1232.6	x2	T-G44			x115
T-F22		1516	x4				
T-F22a		1516	x4				
T-B29		160	x4				
TOP 2							
T-B23		1342	x2				
T-B24		1342	x6				
T-B25		1342	x2				
T-26		1216	x4				
T-27		616	x2				
T-B38		1340	x2				
T-B39		1340	x2				
T-F28		1559	x2				
DOOR							

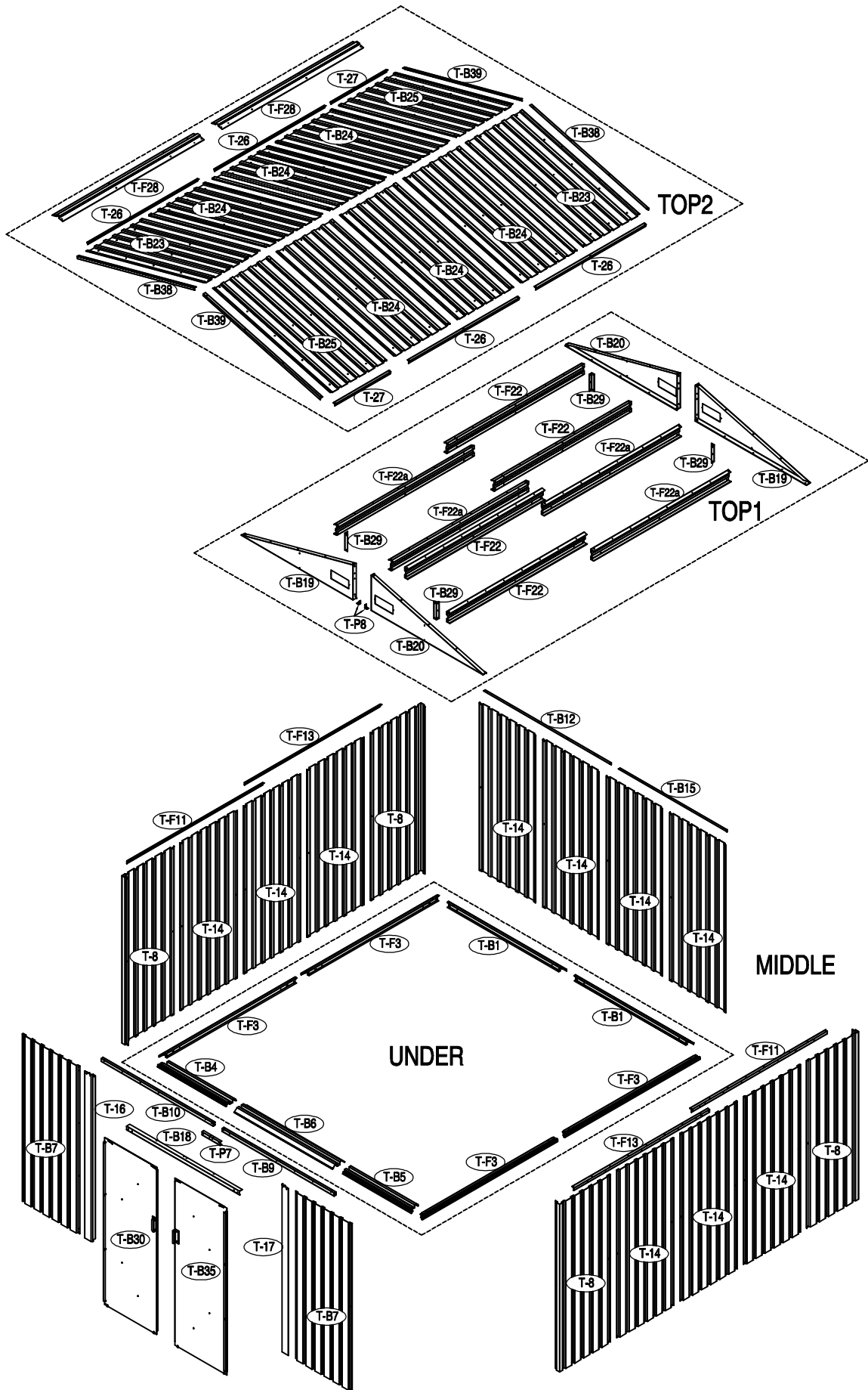

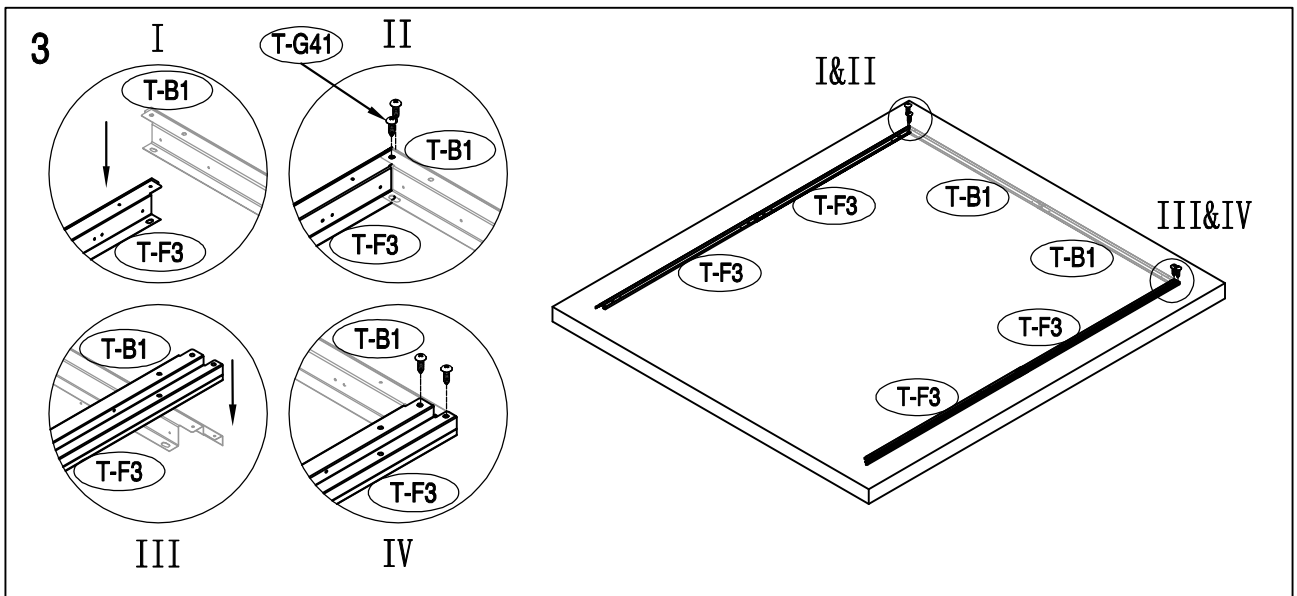
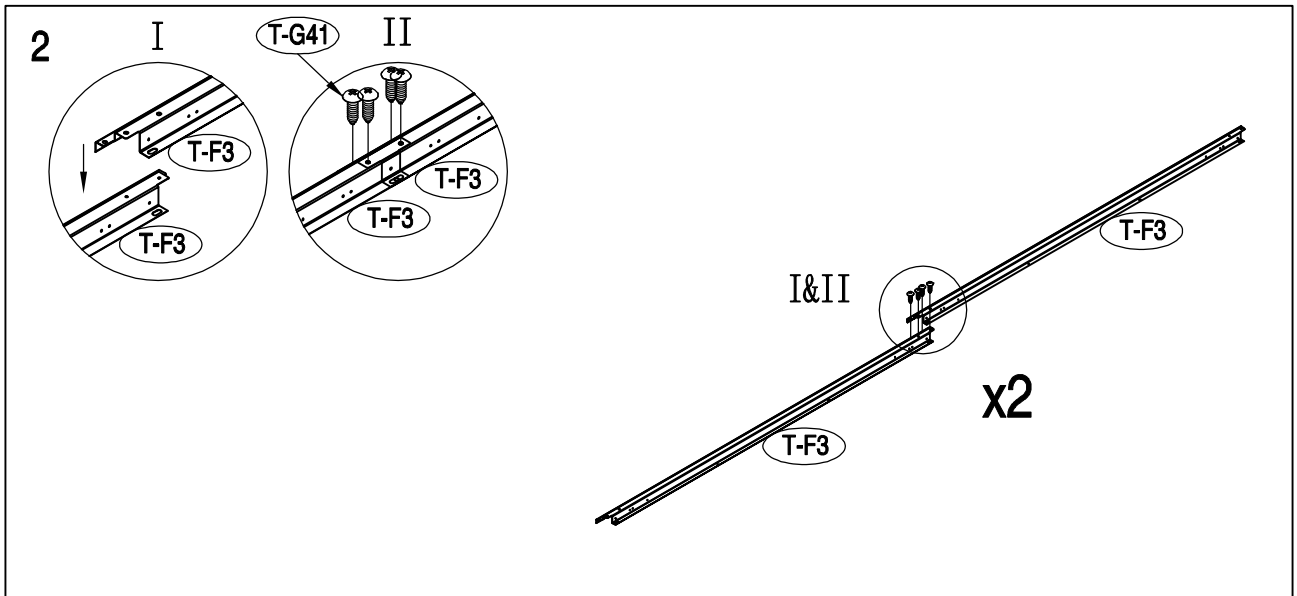
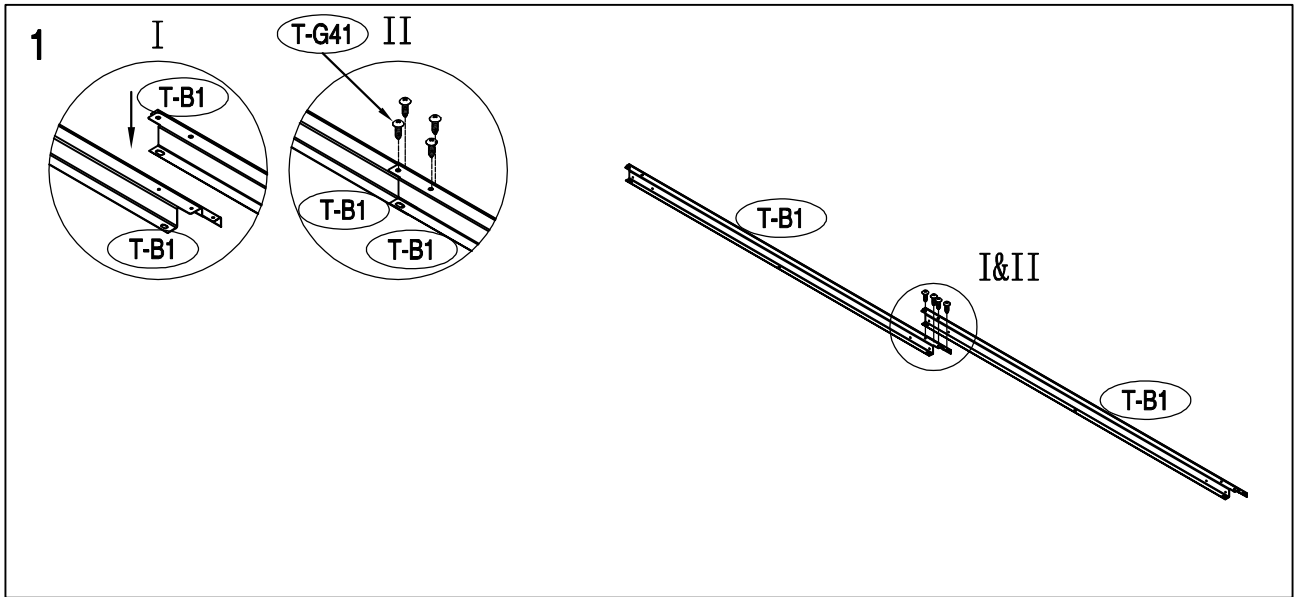

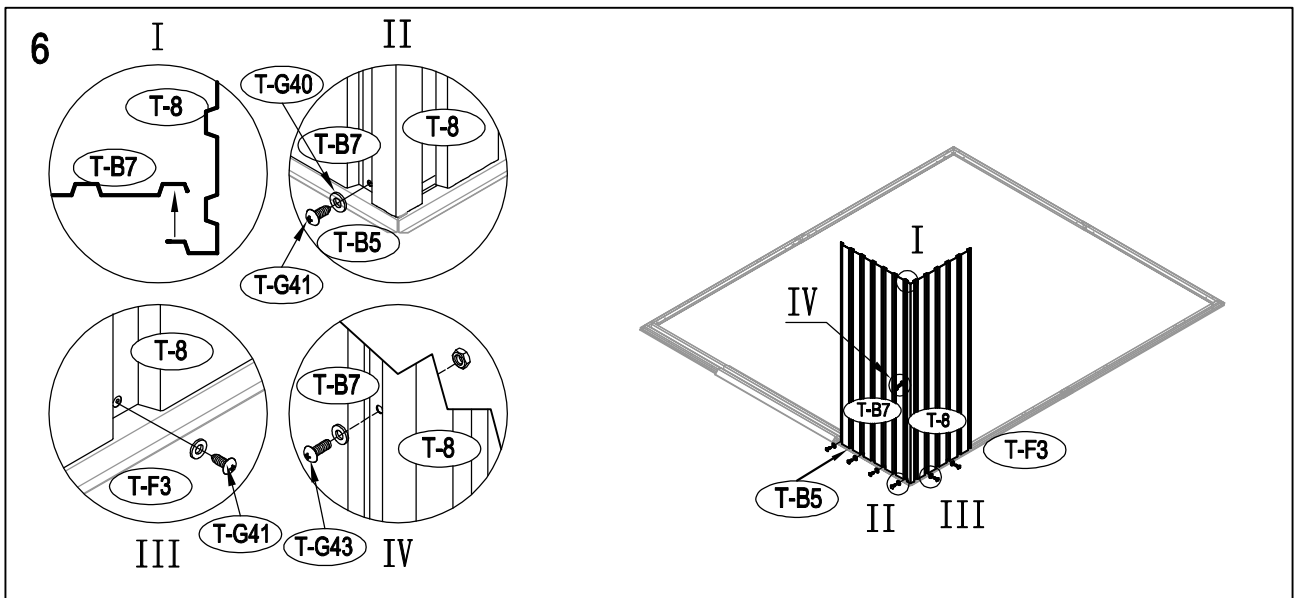
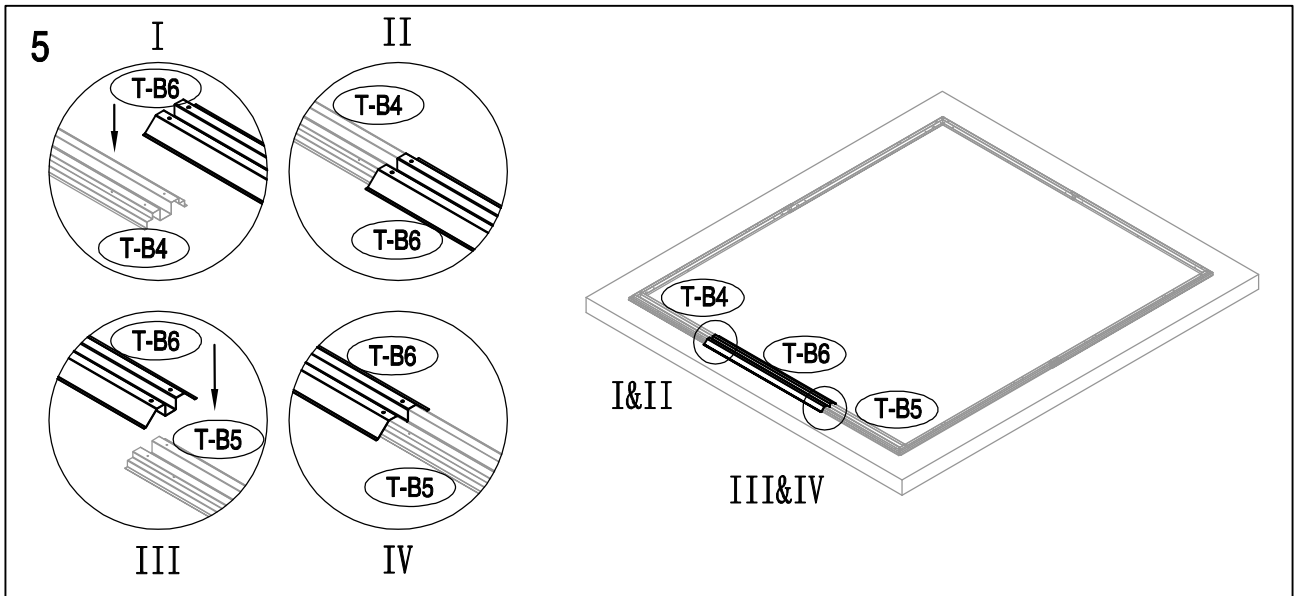
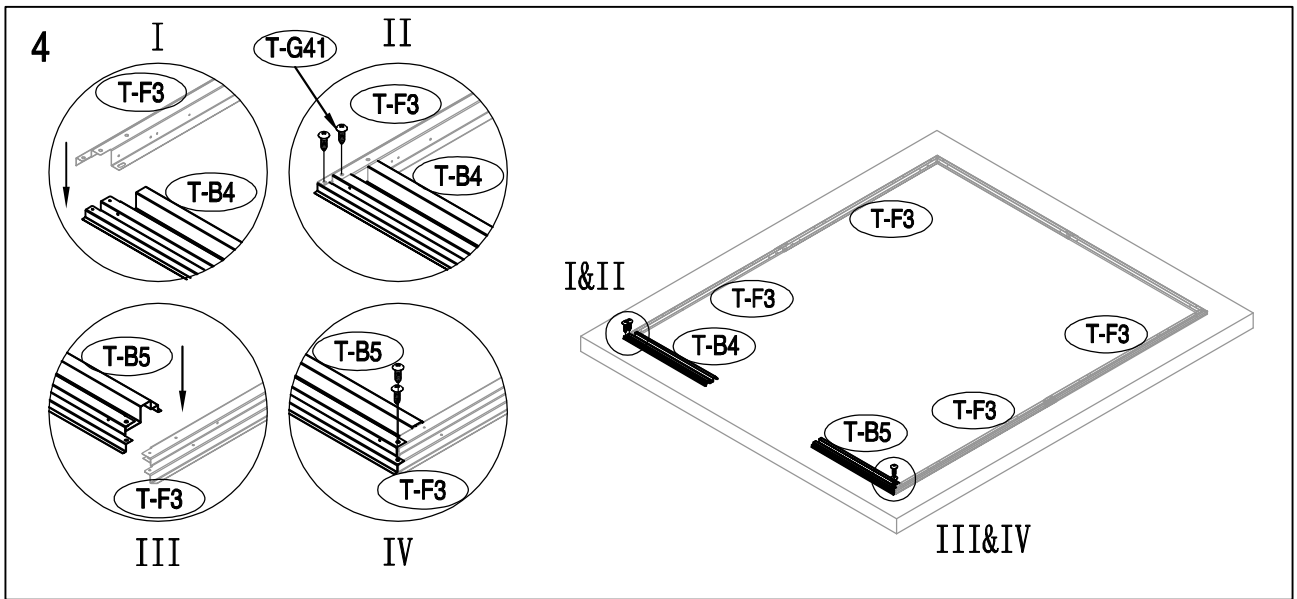

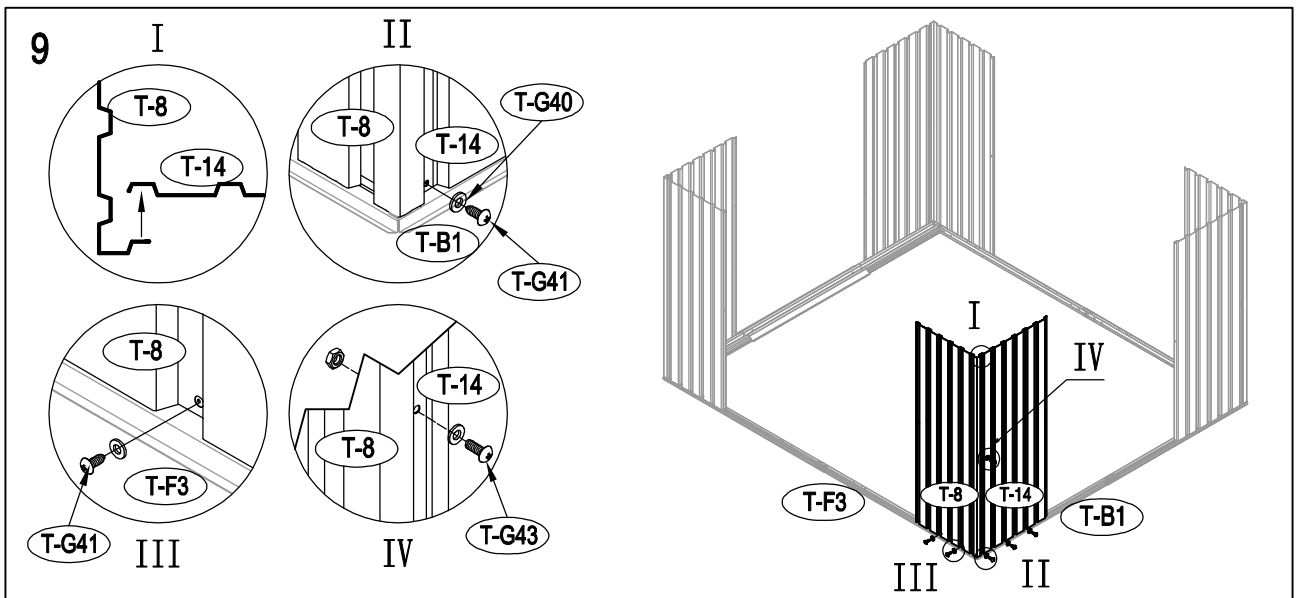
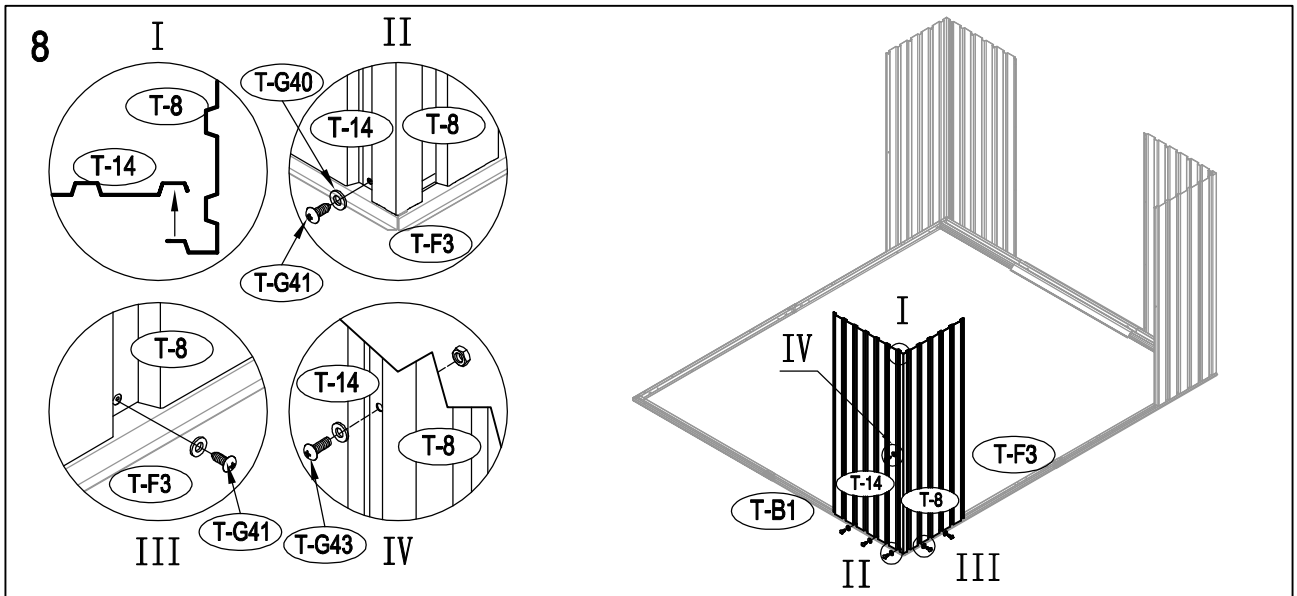
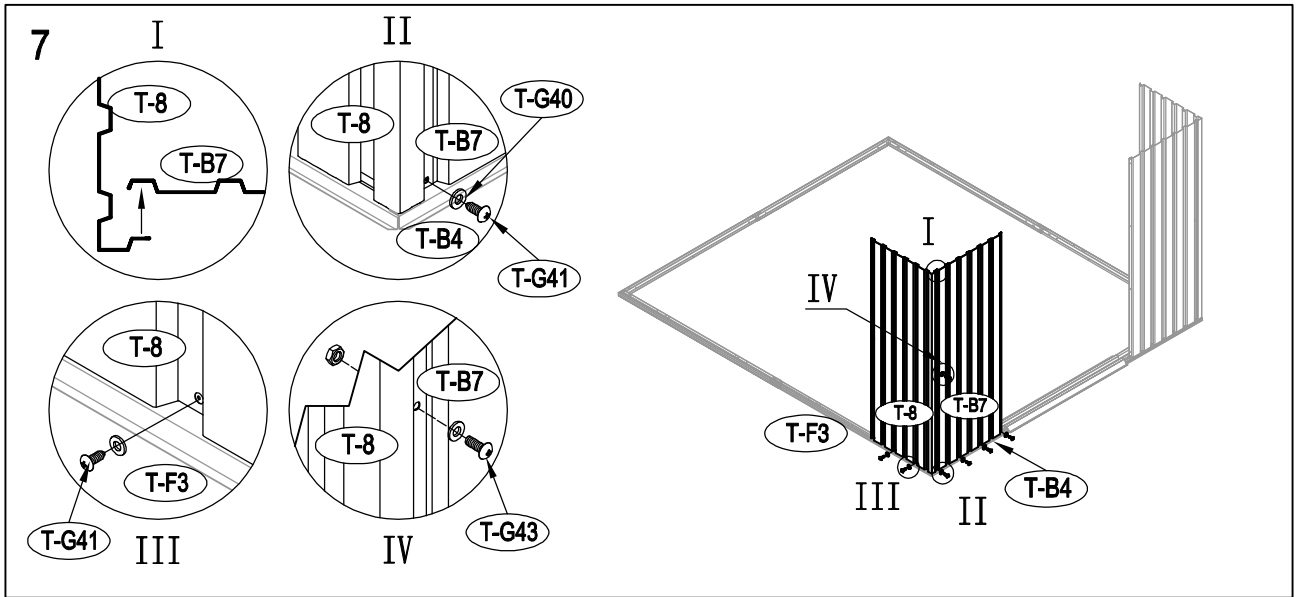

10

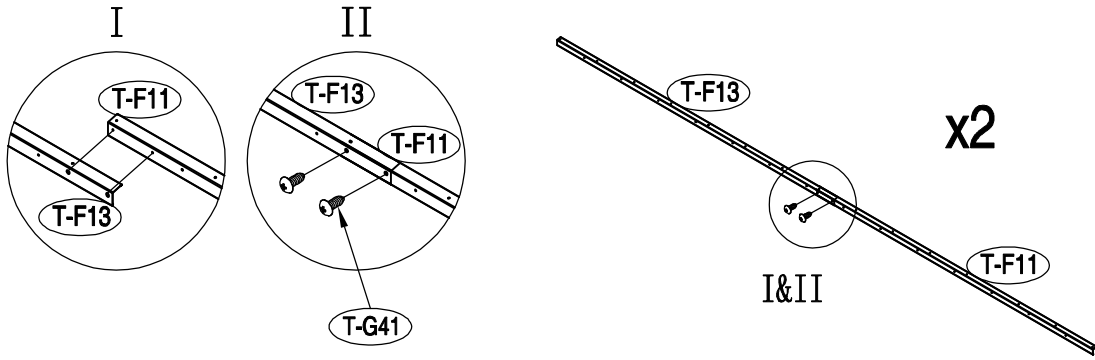

11

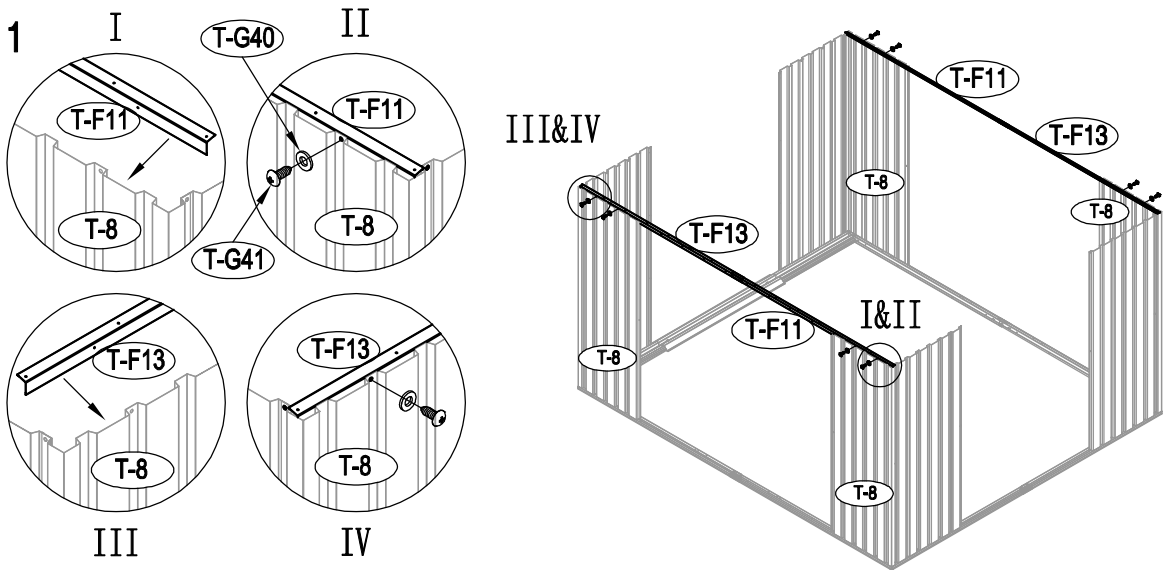

12

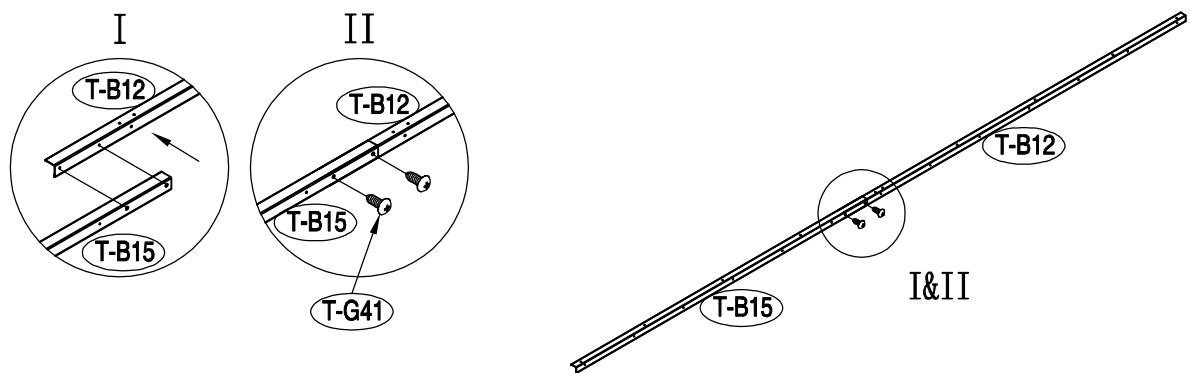

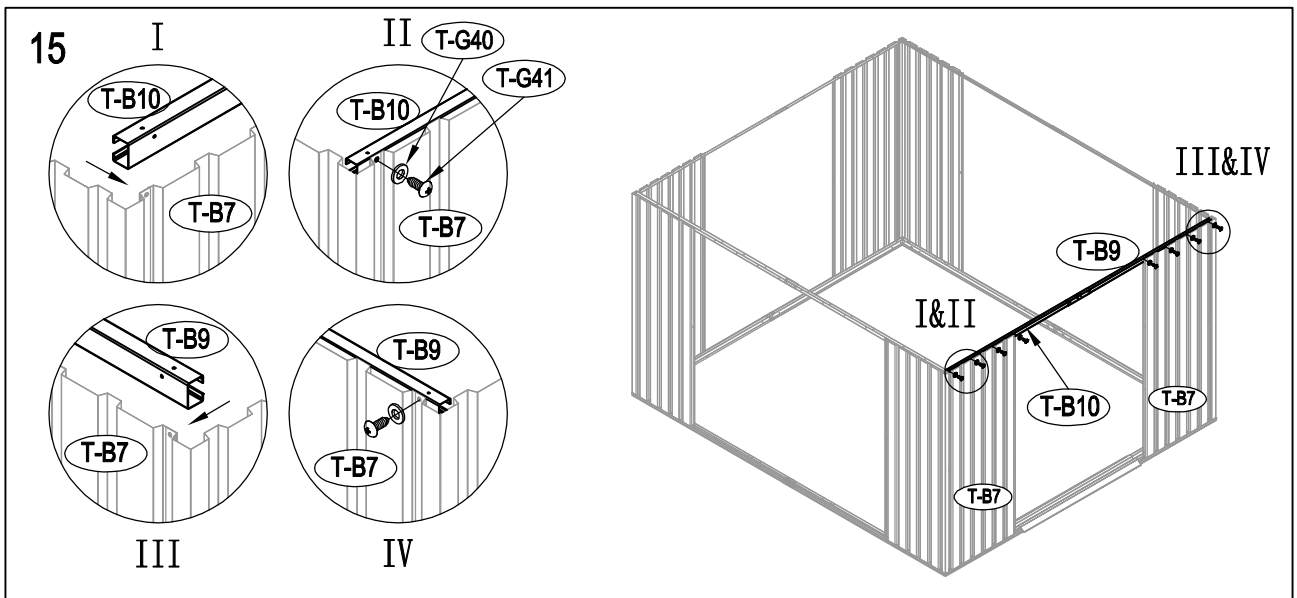
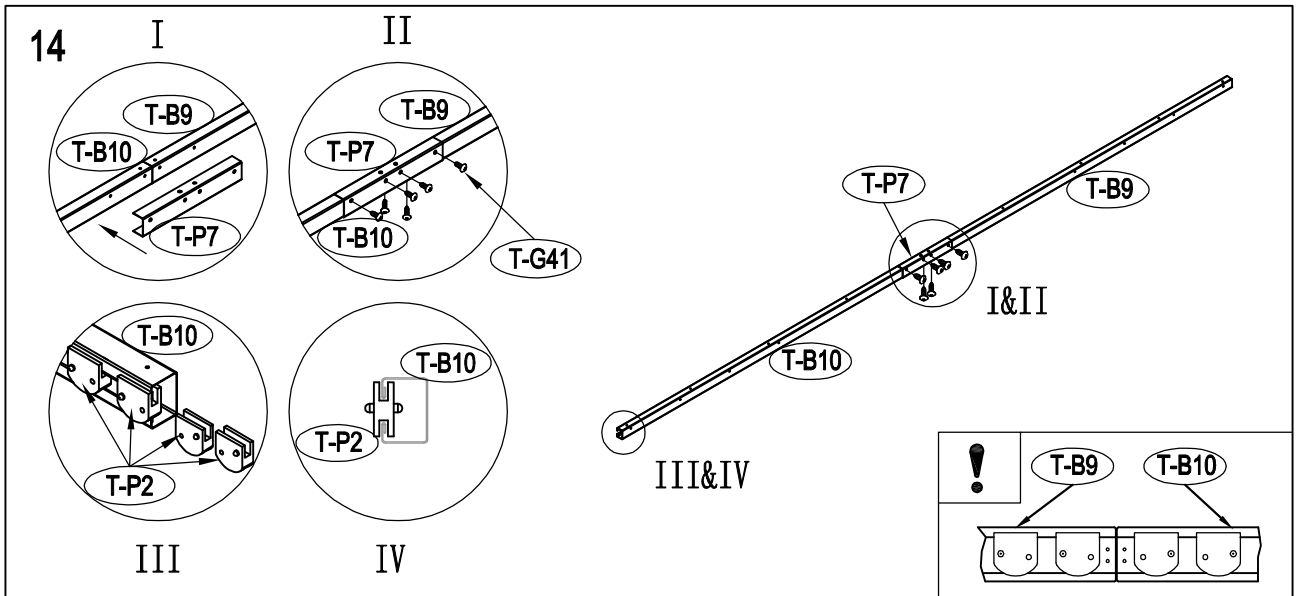
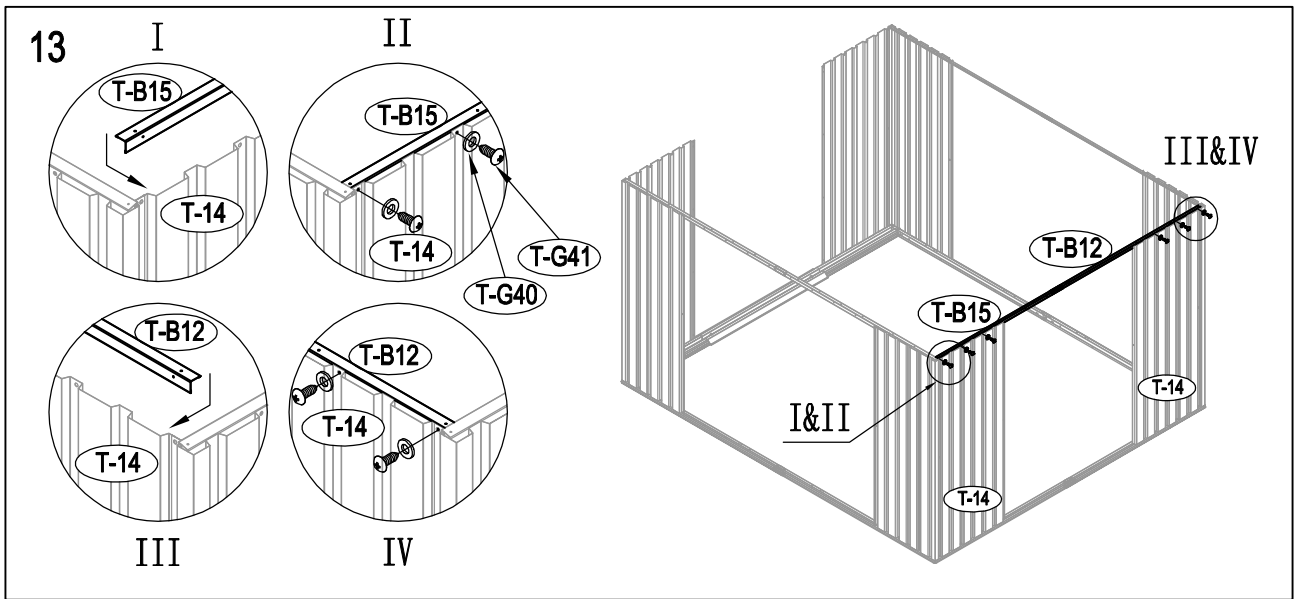

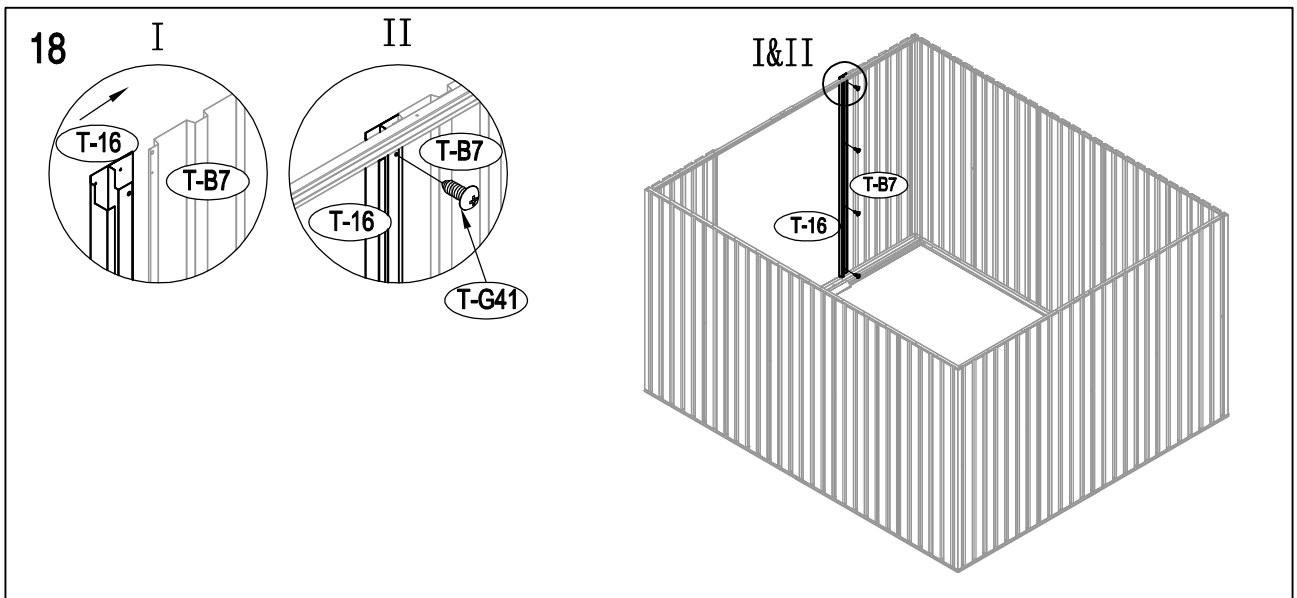
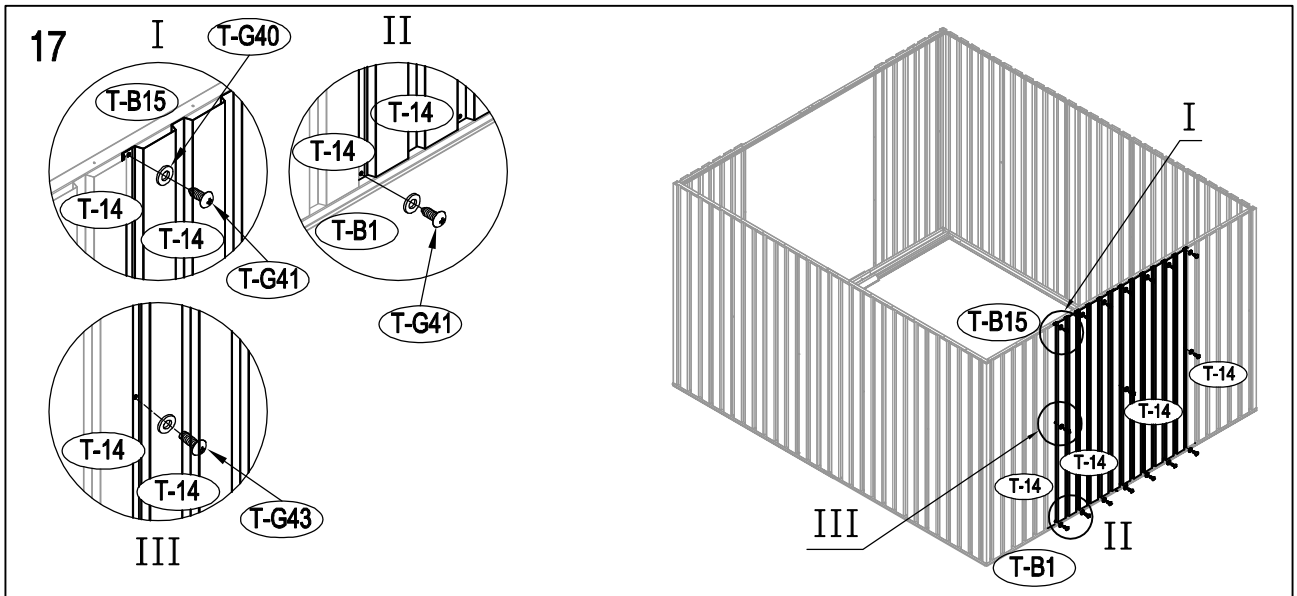
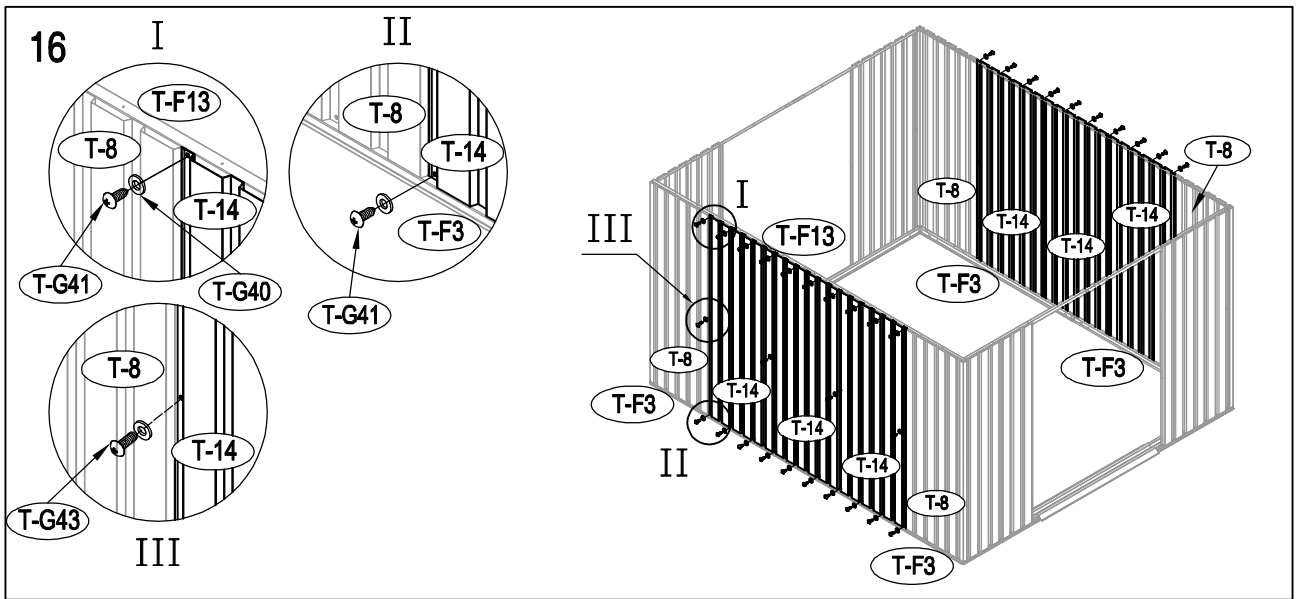

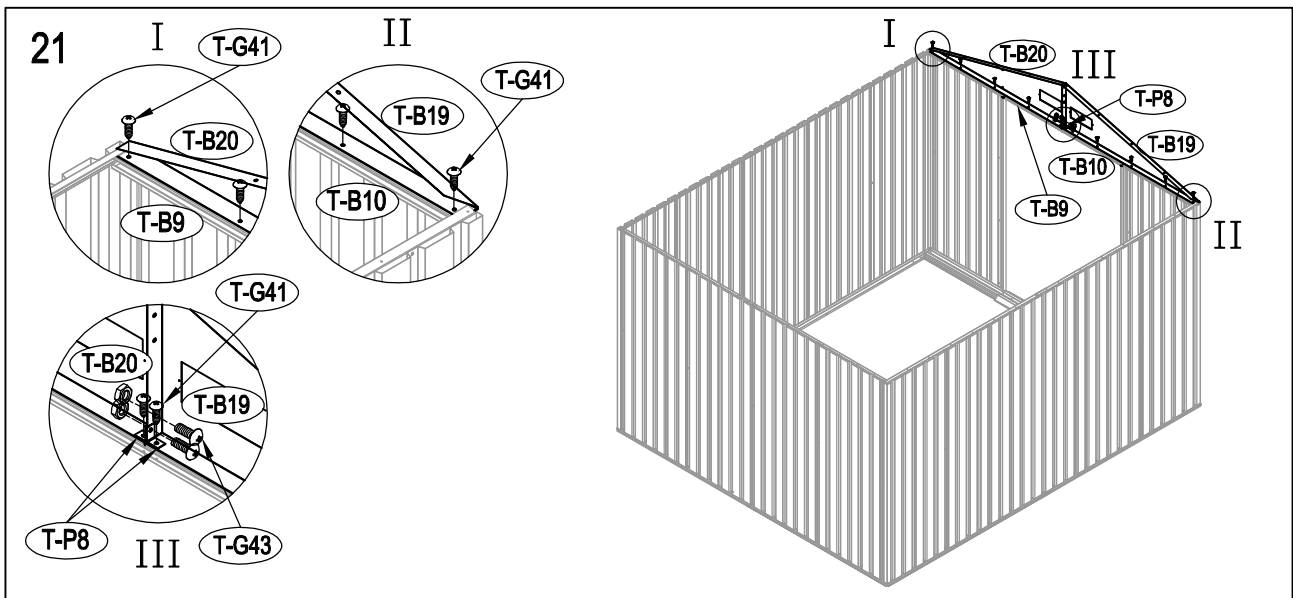
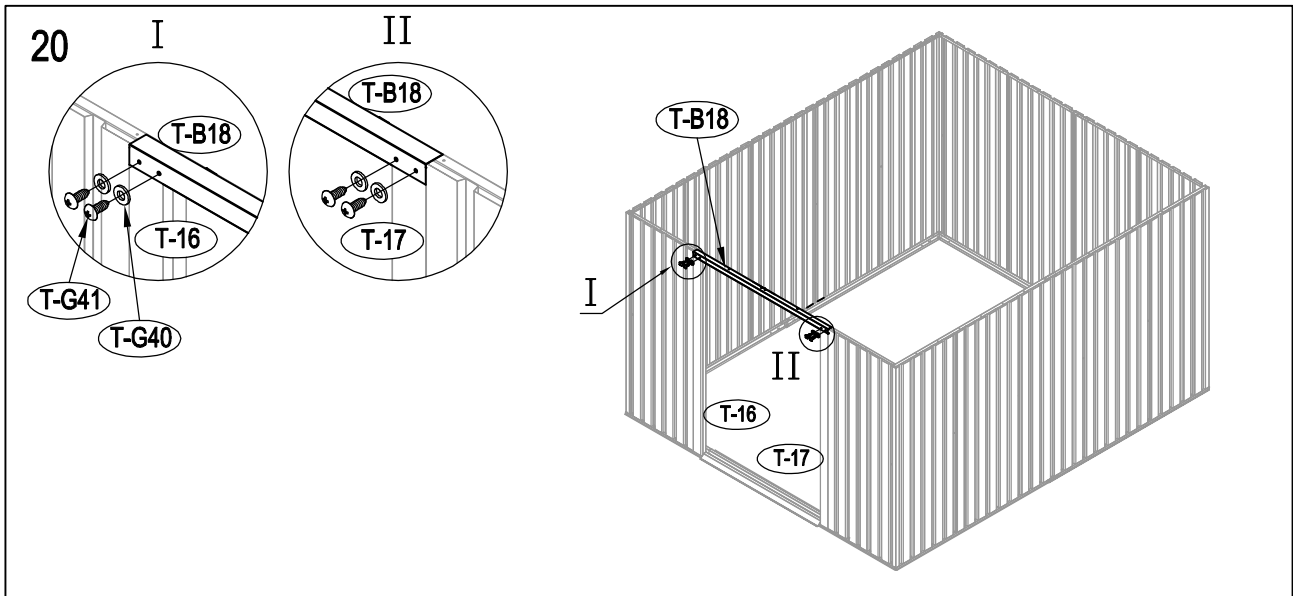
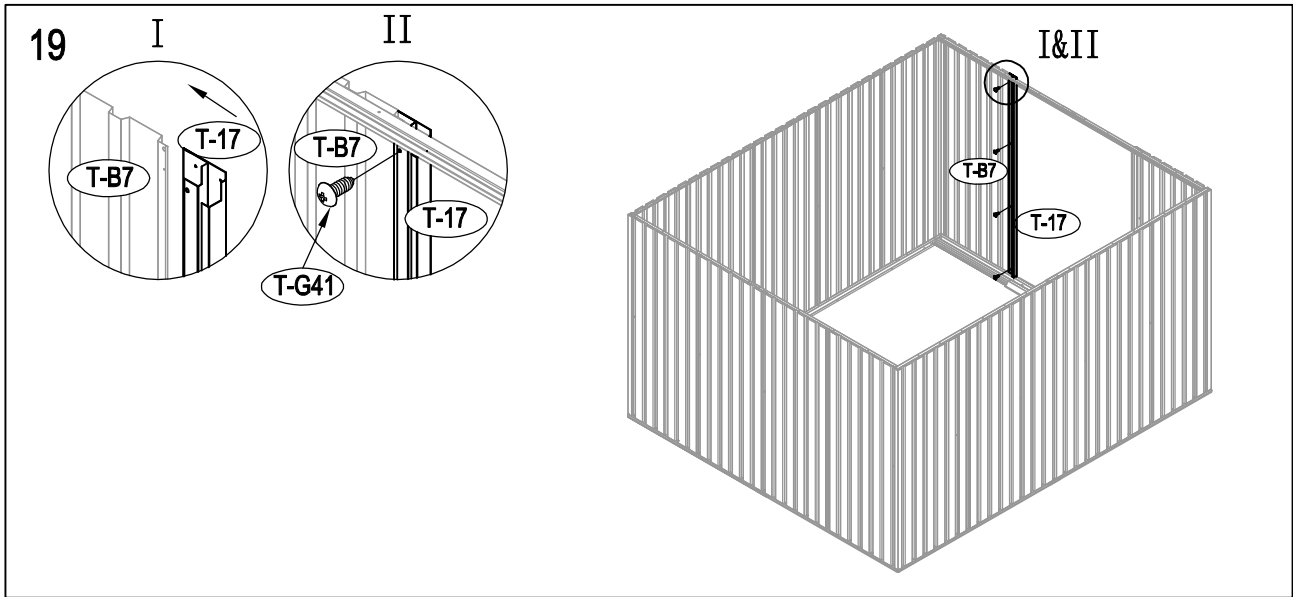

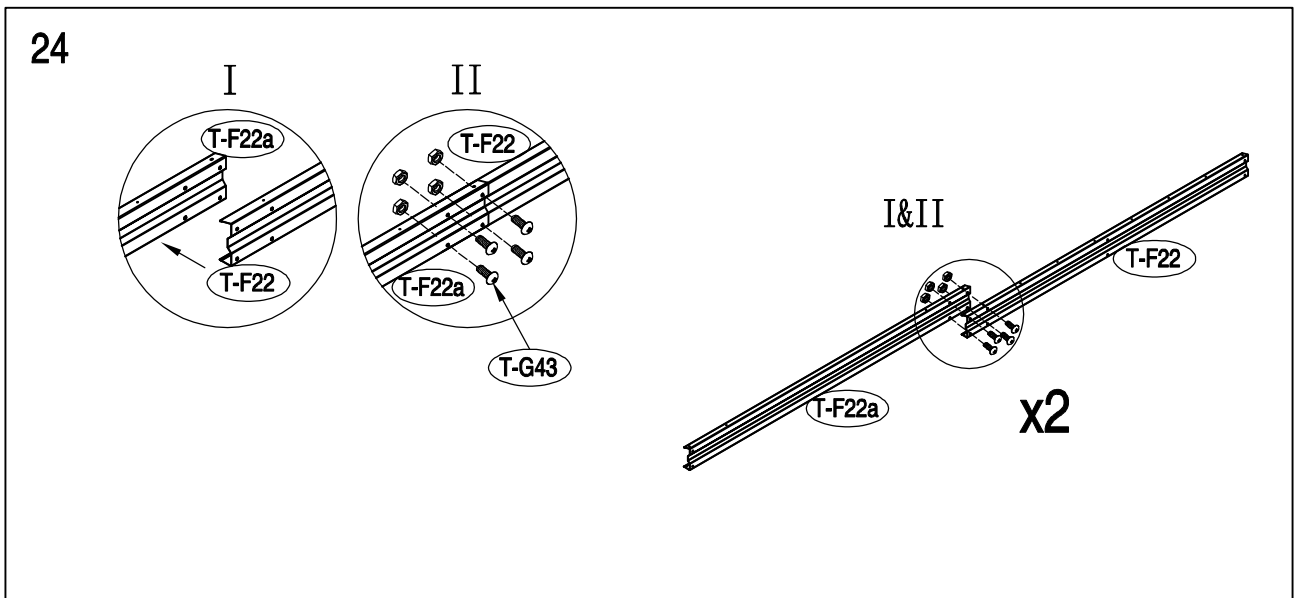
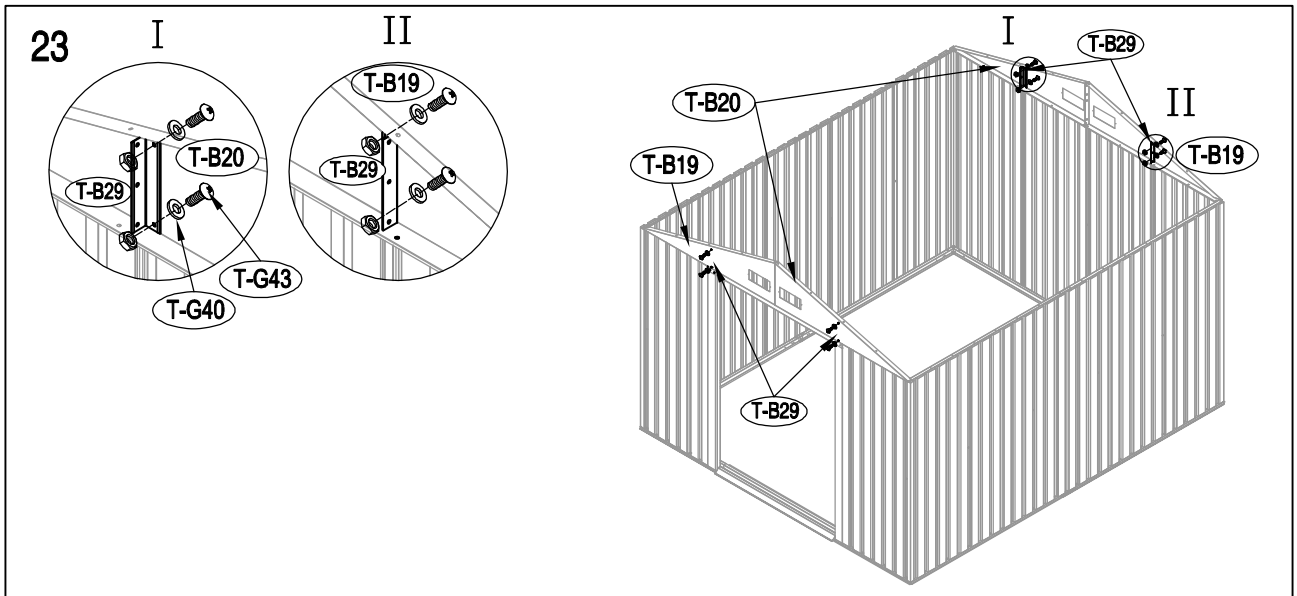
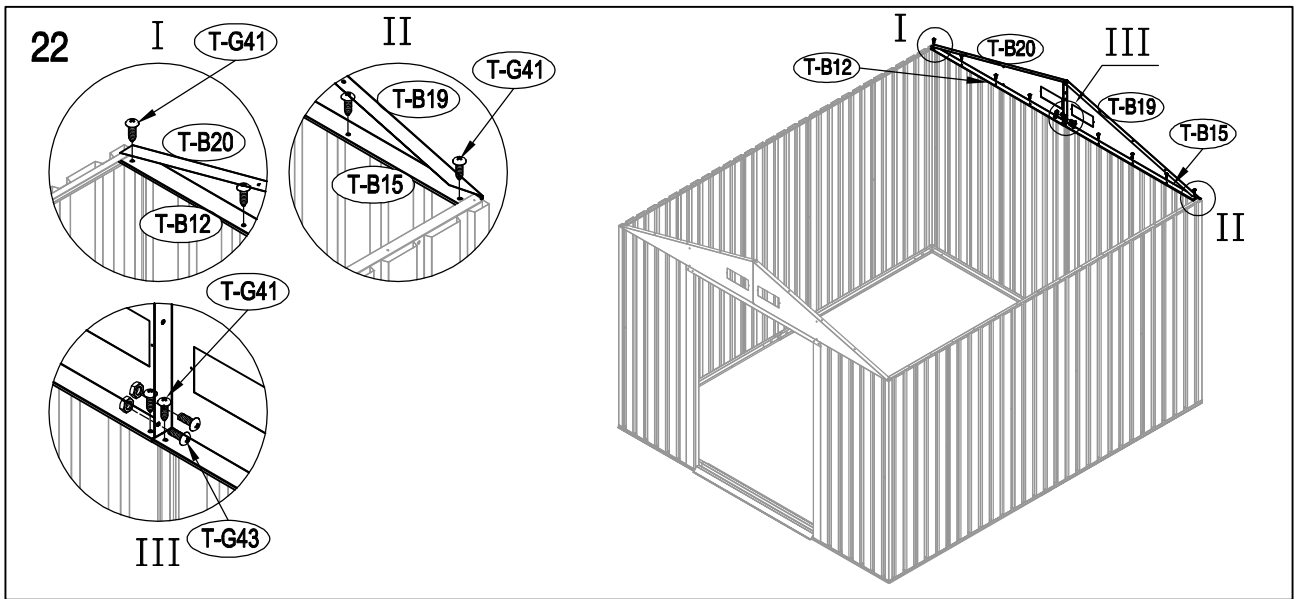

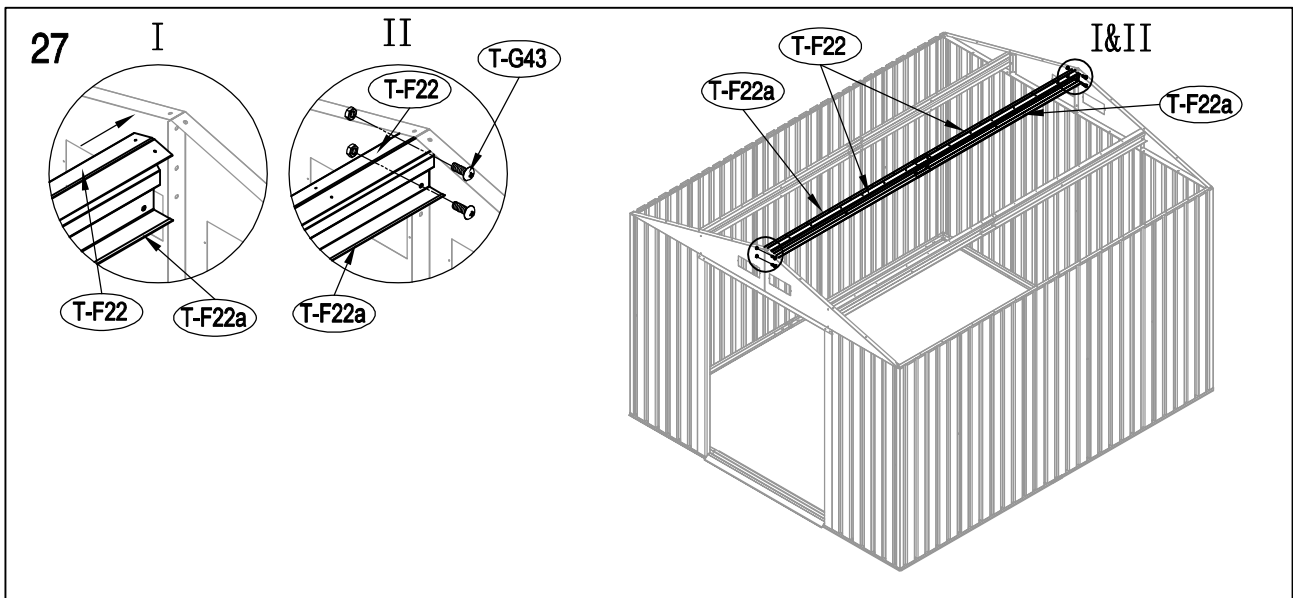
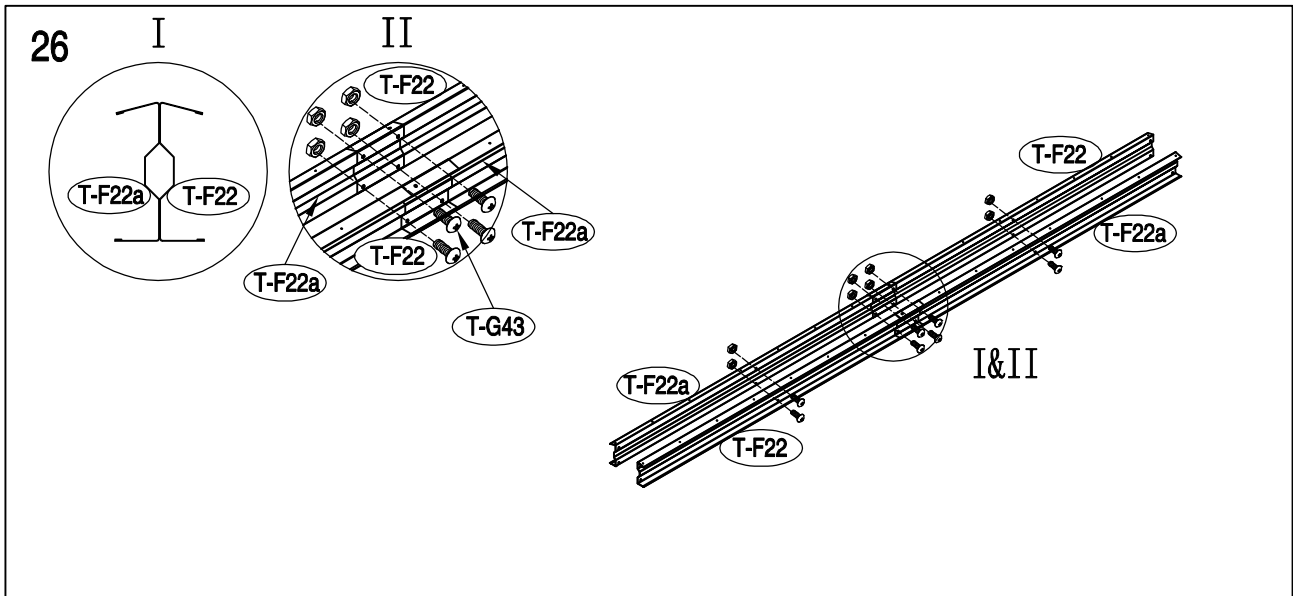
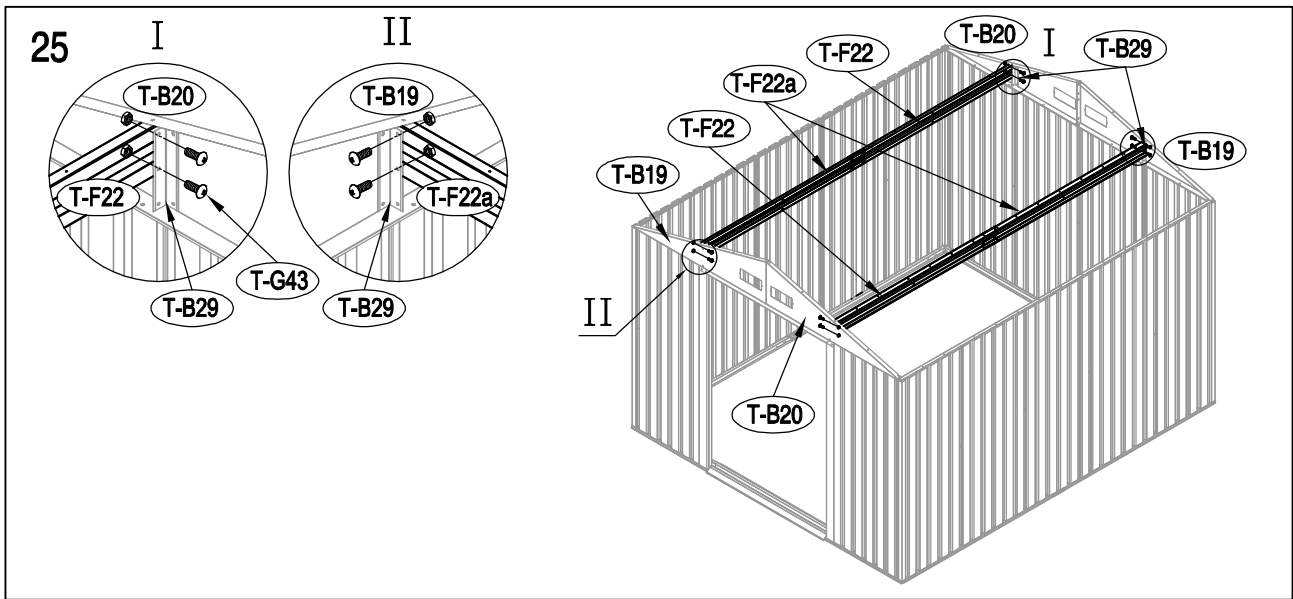

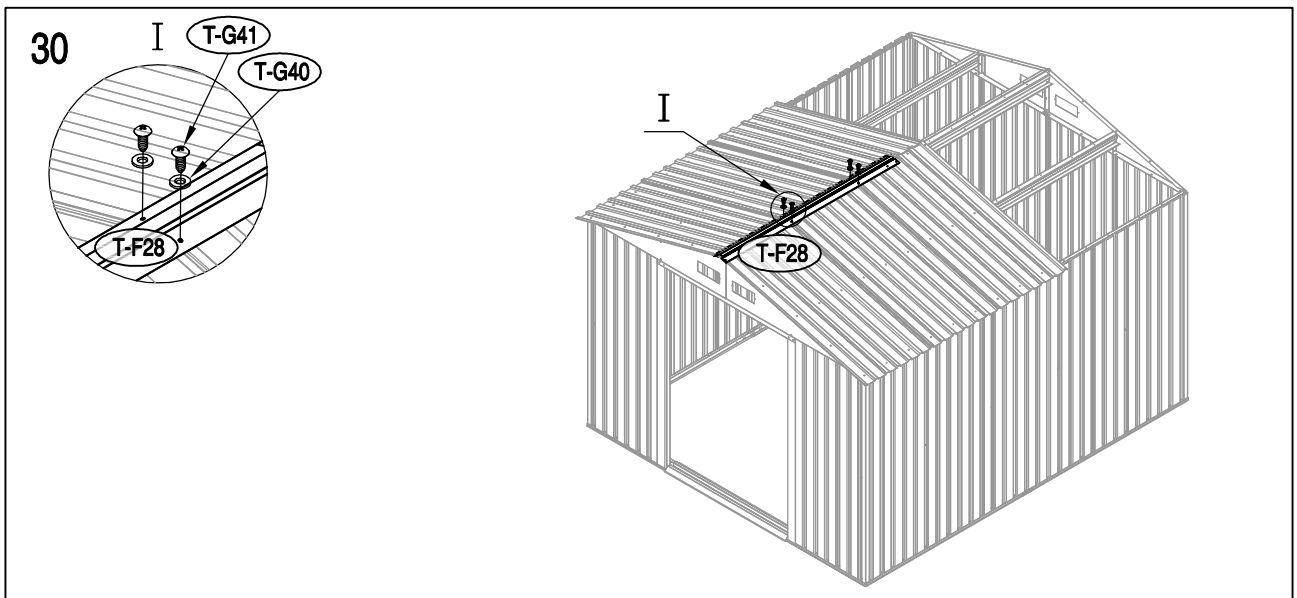
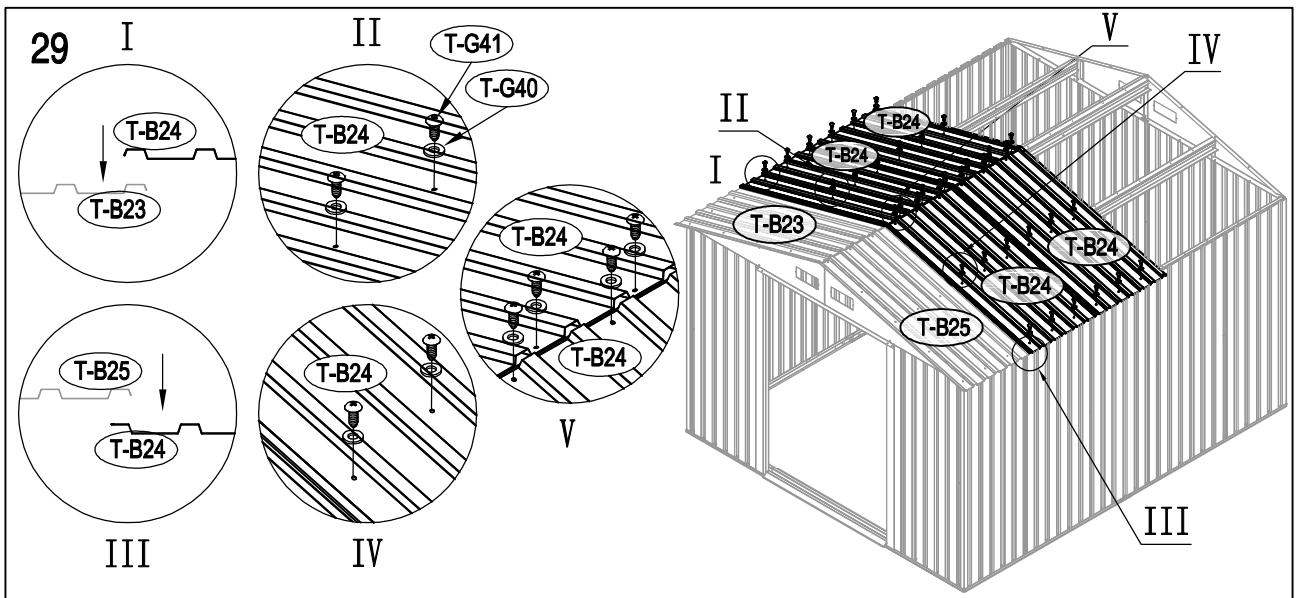
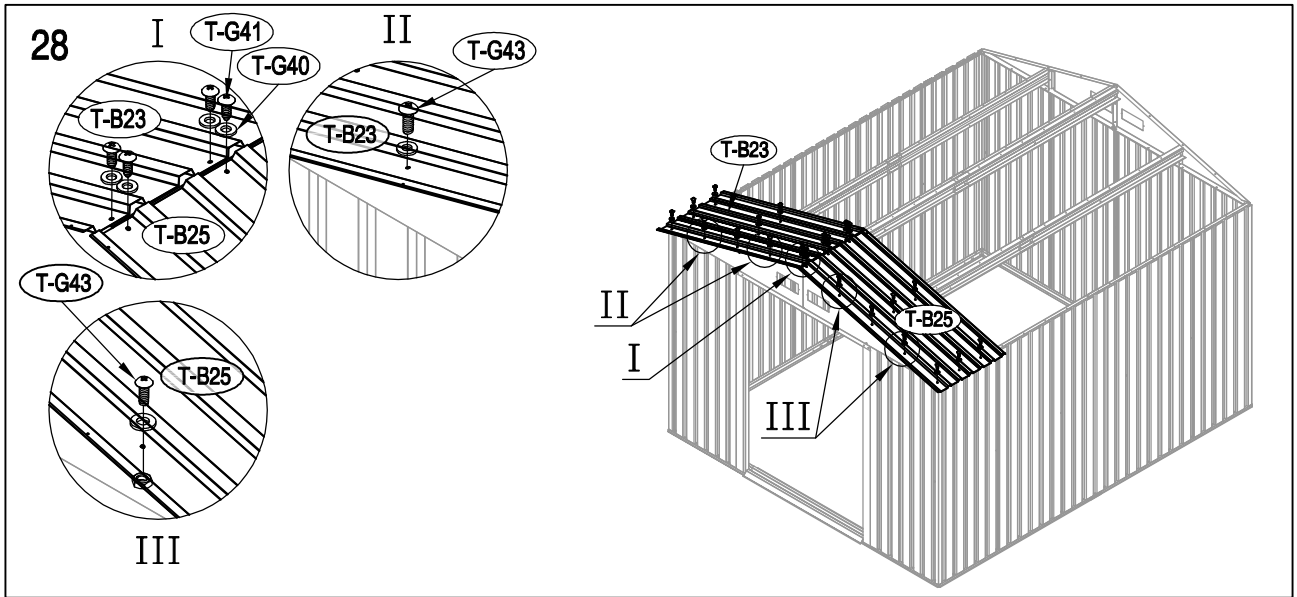

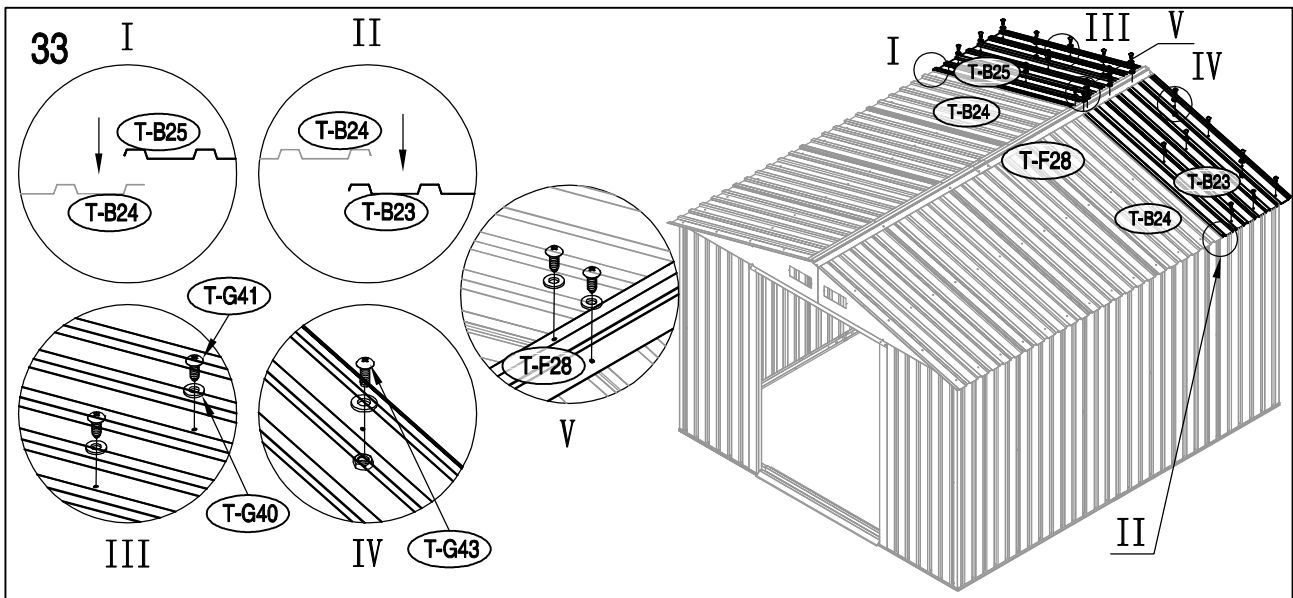
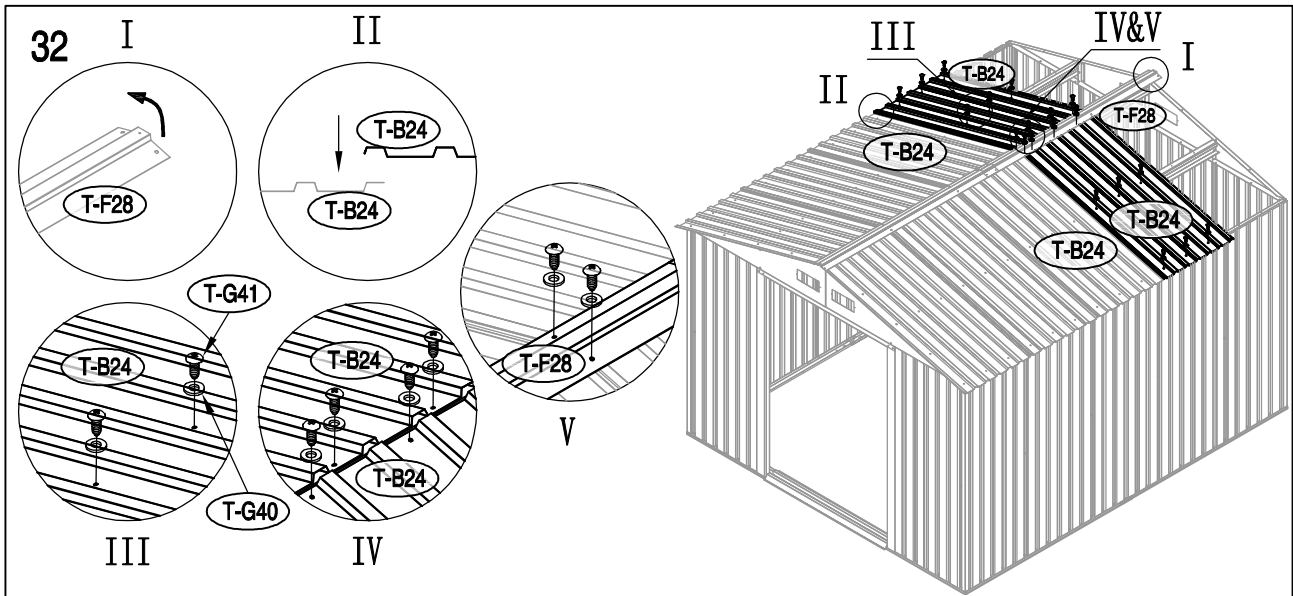
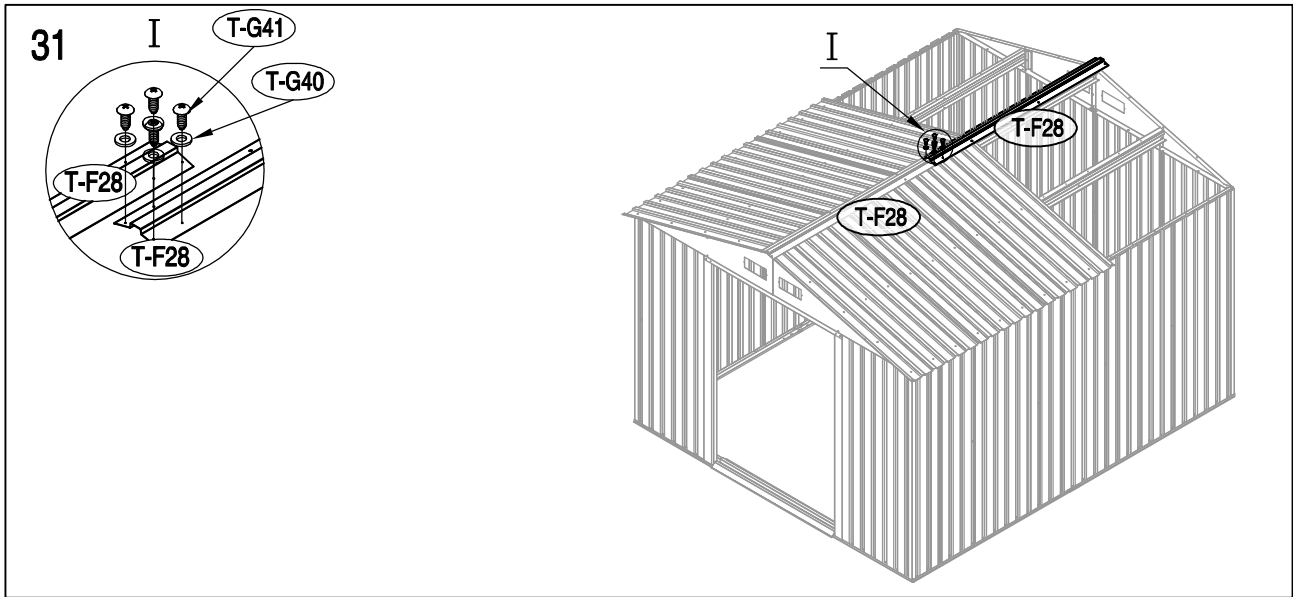

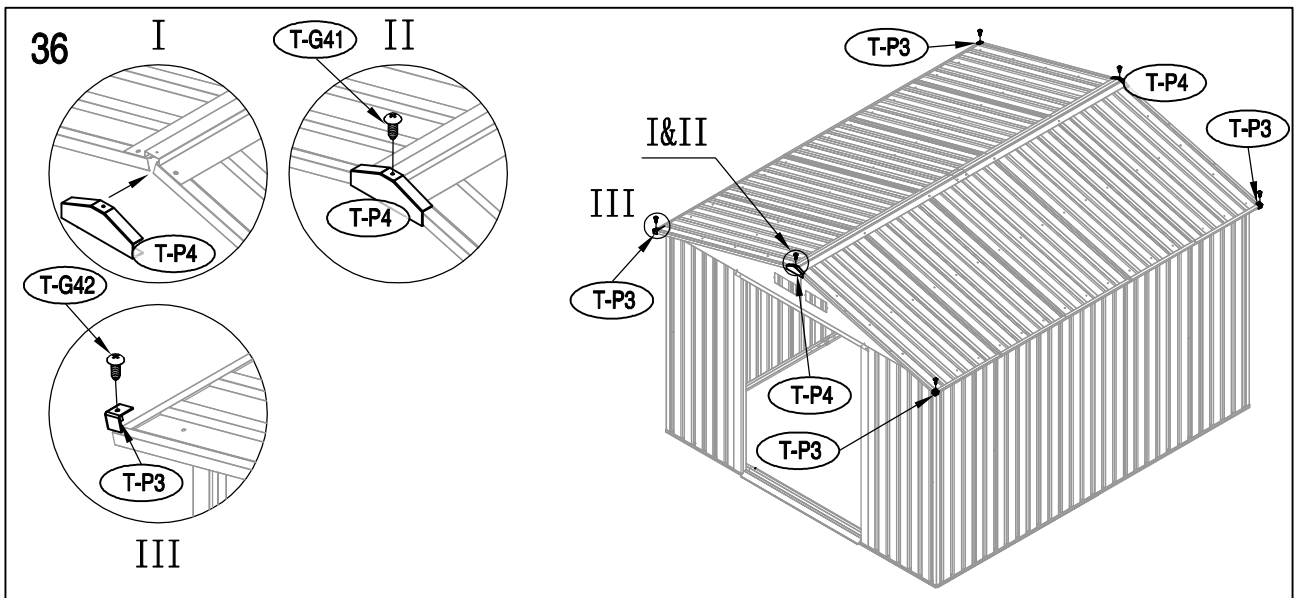
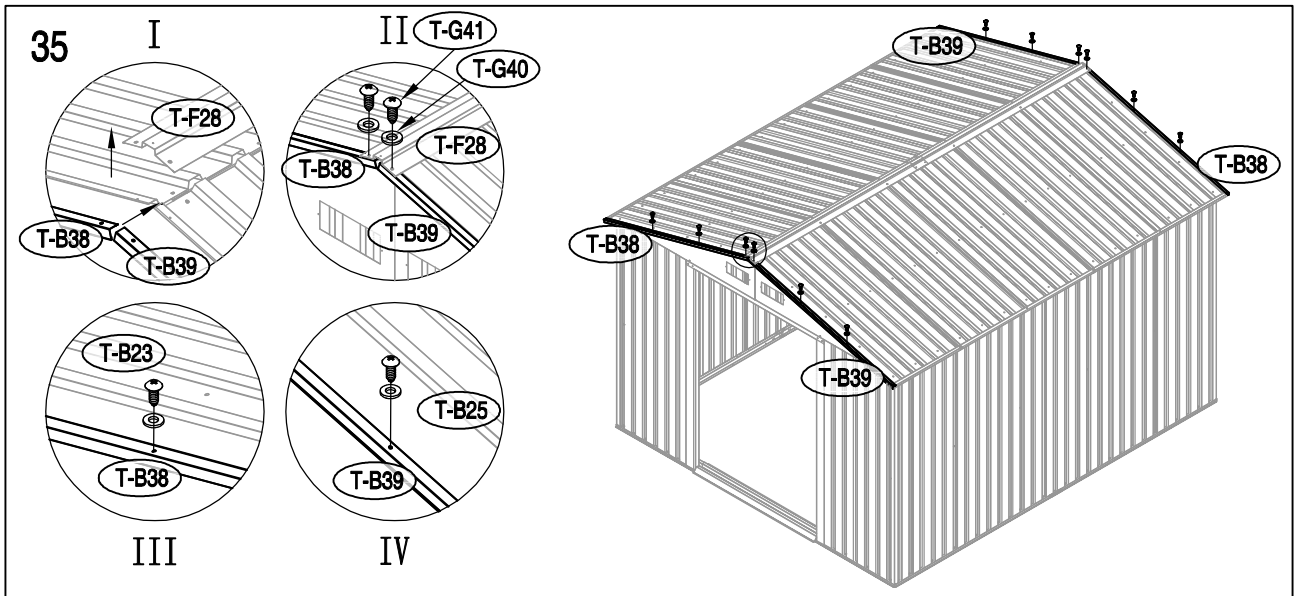
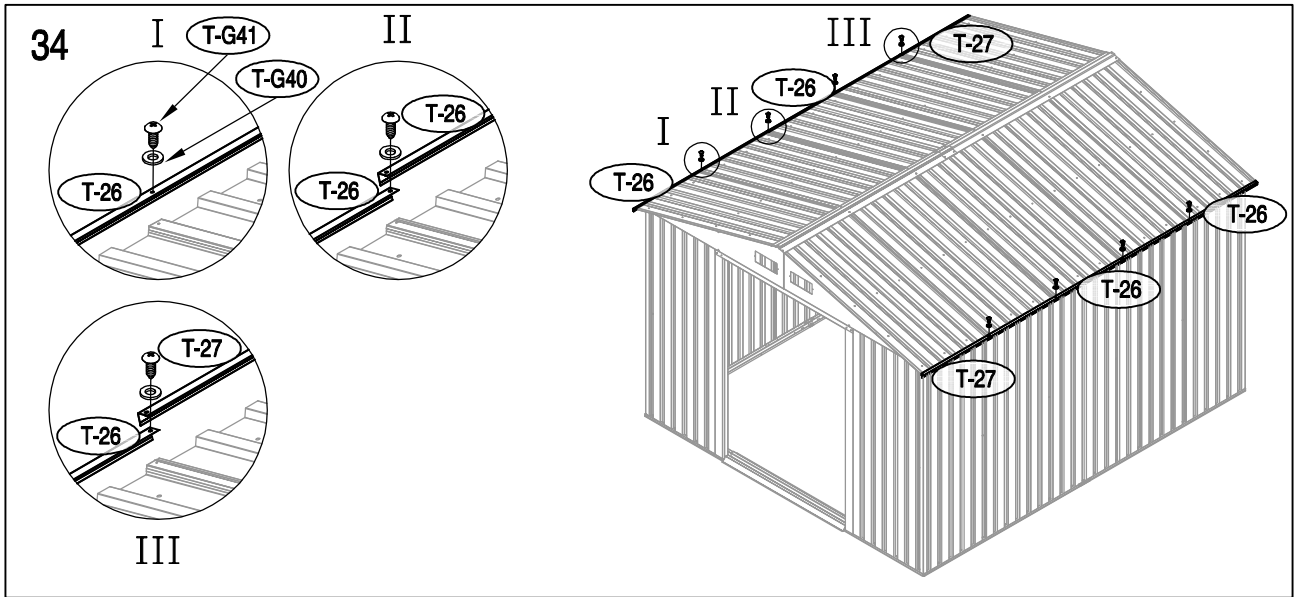

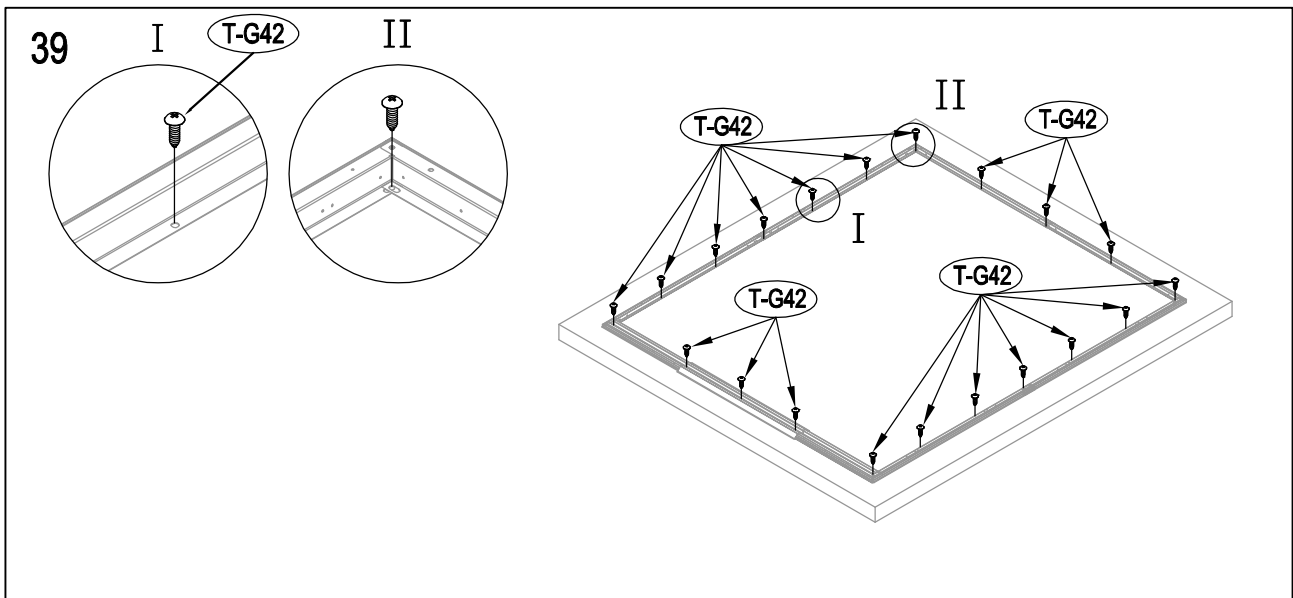
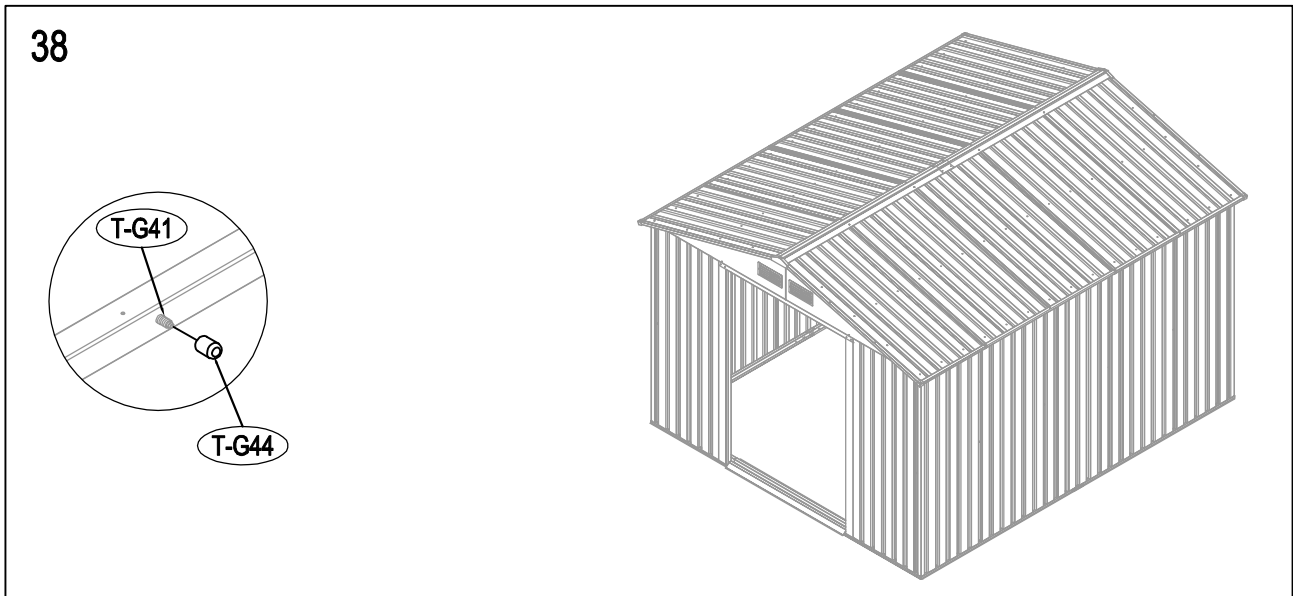
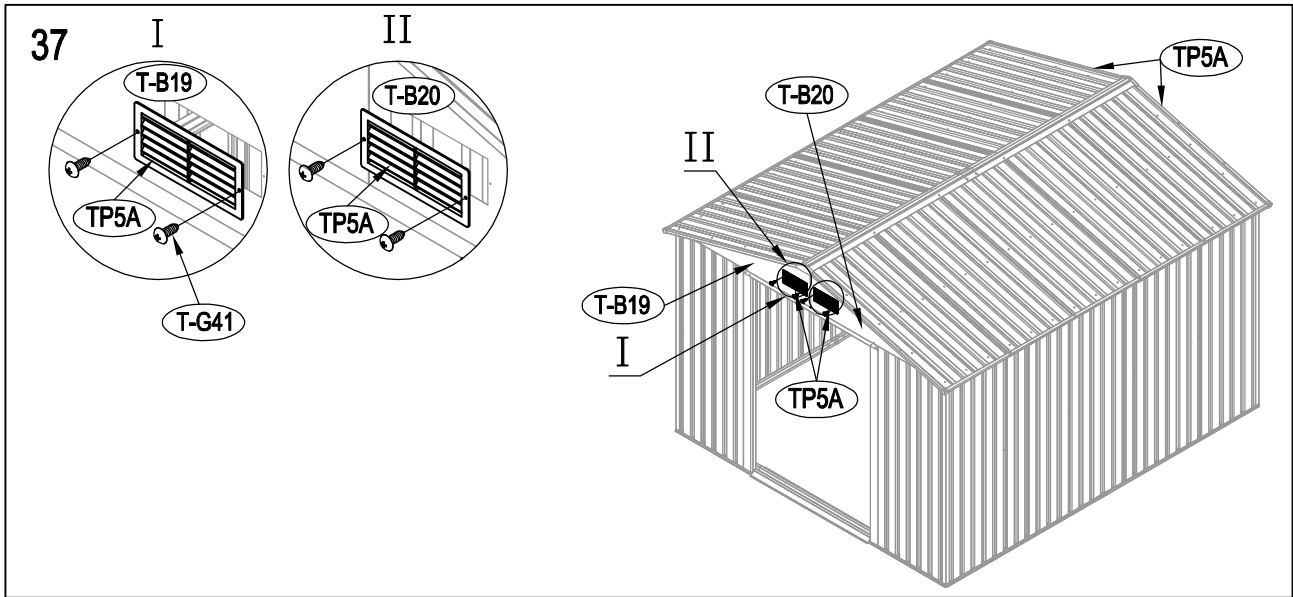

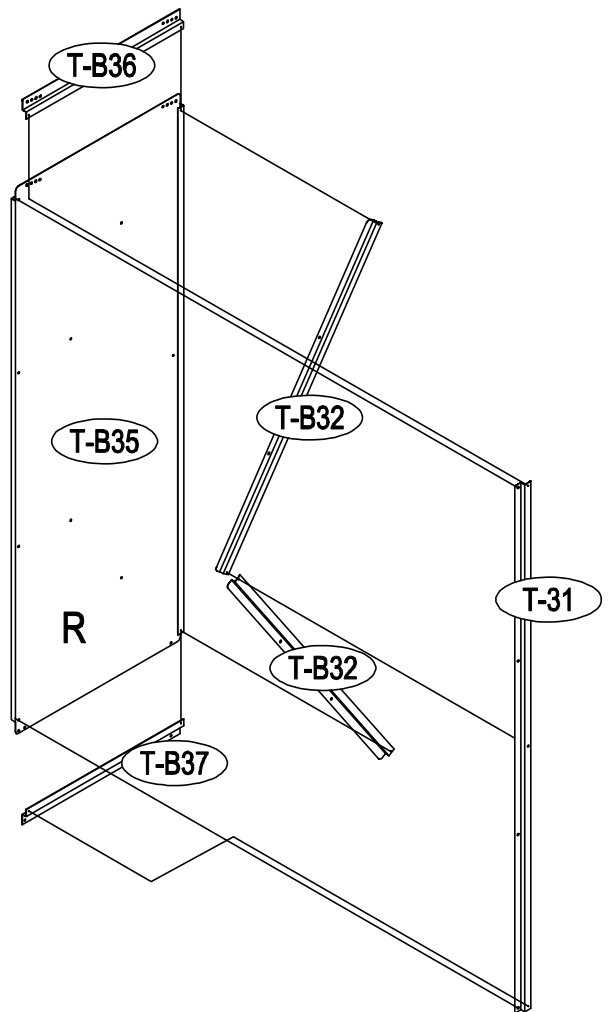
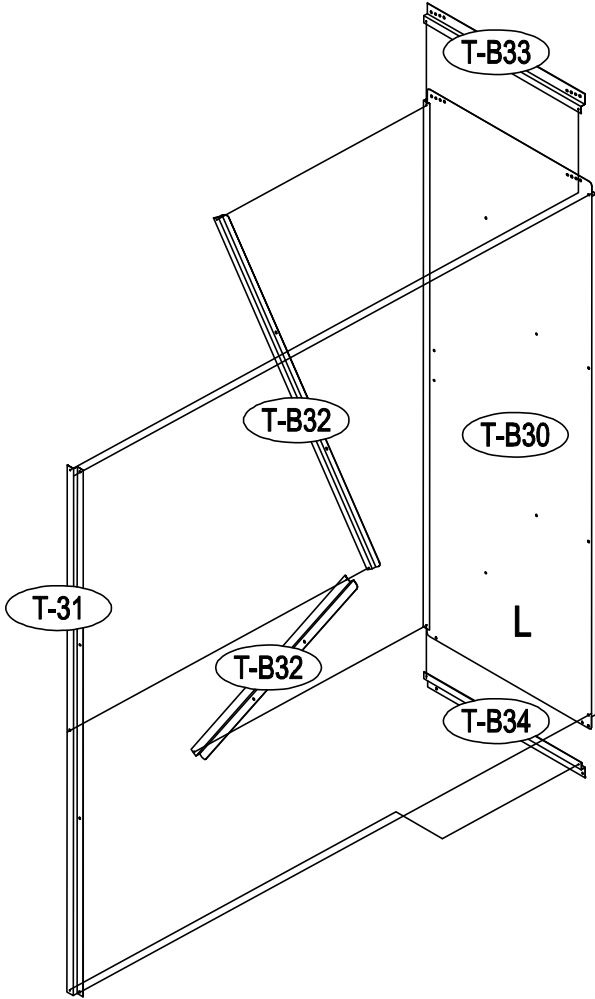

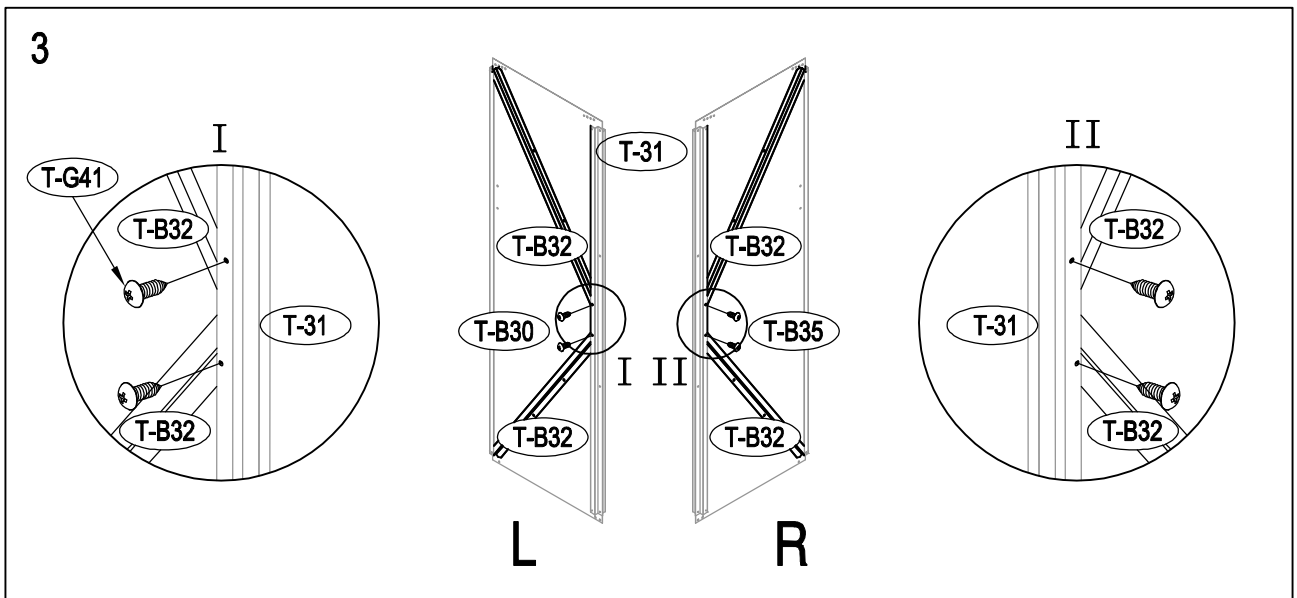
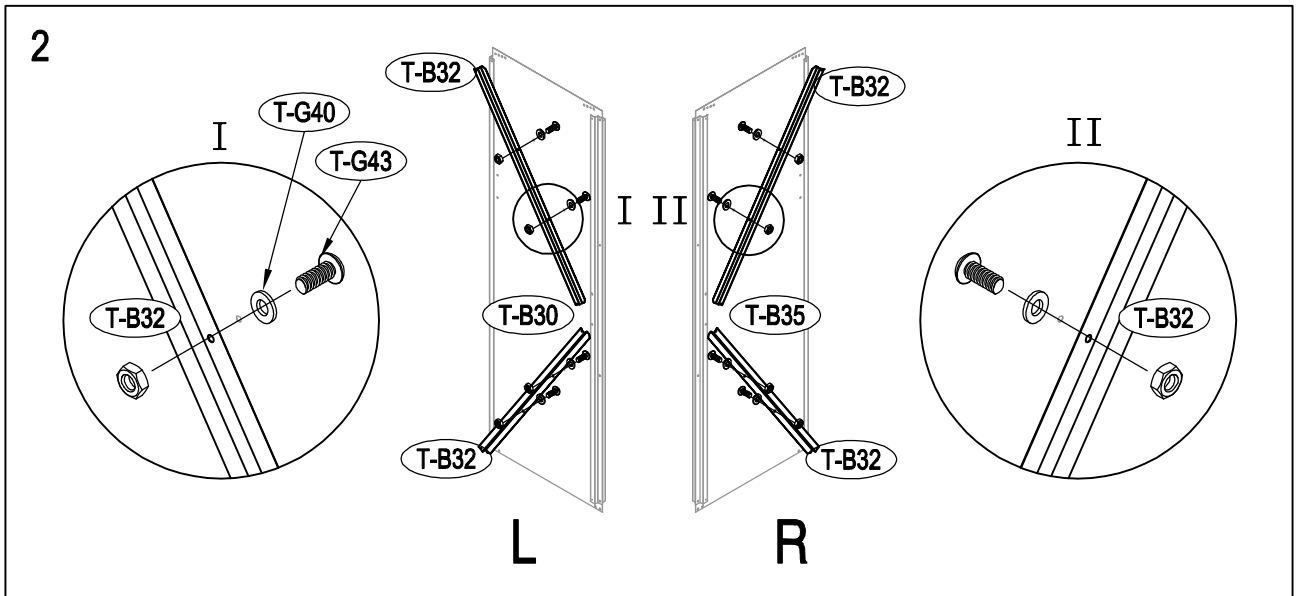
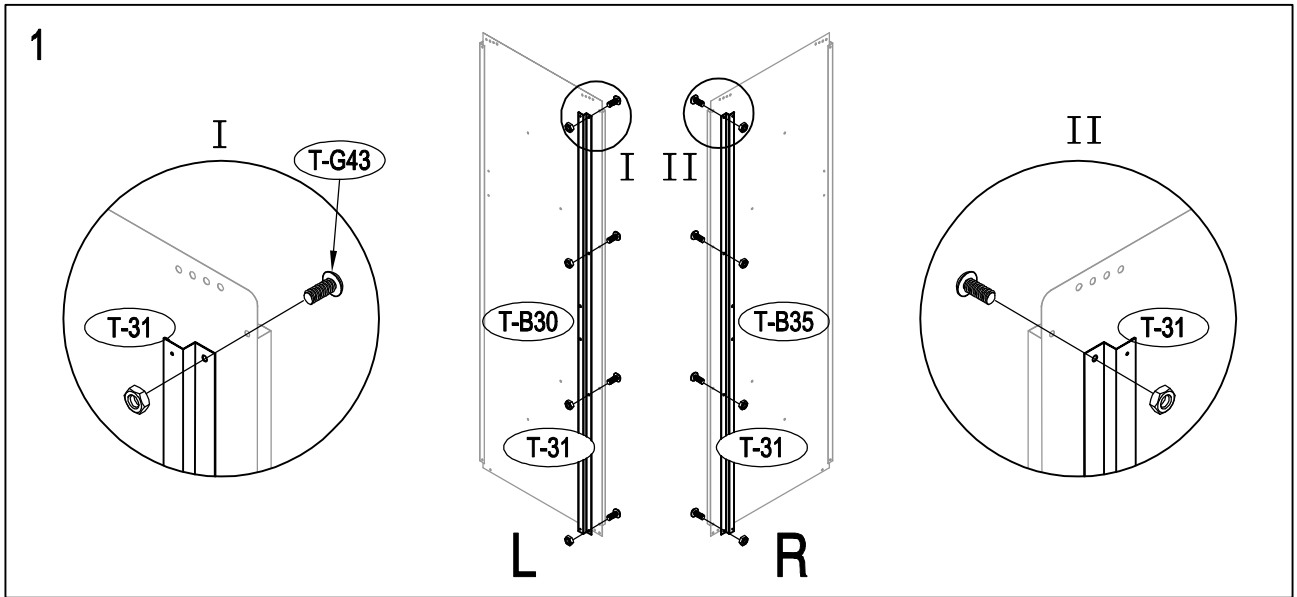

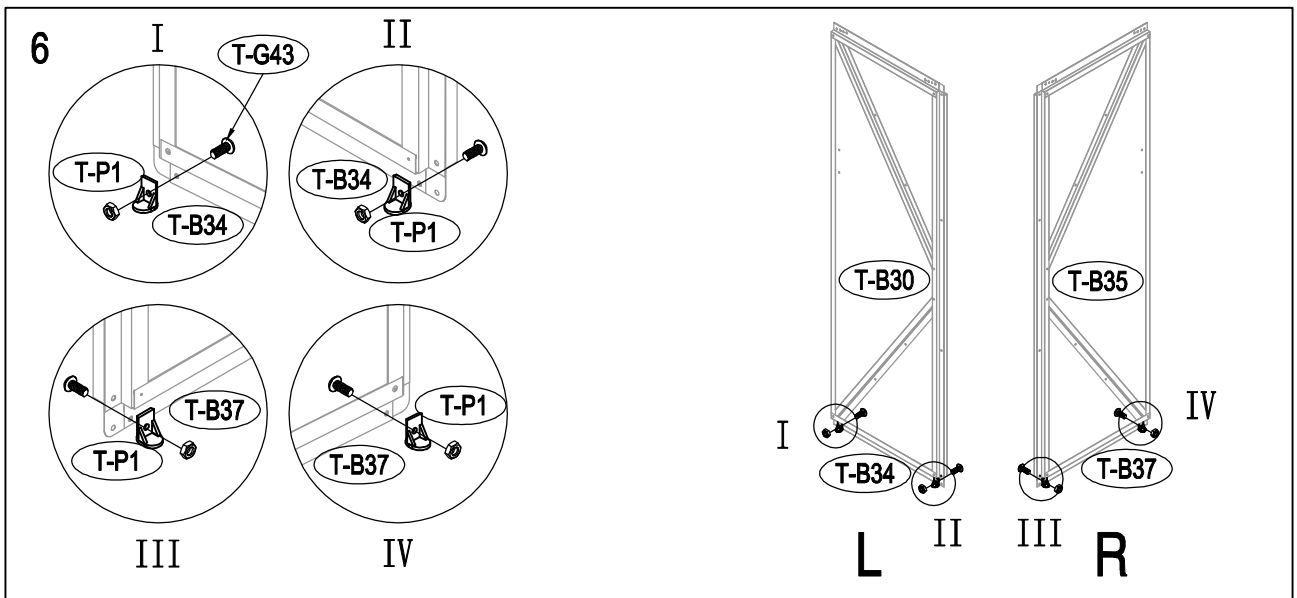
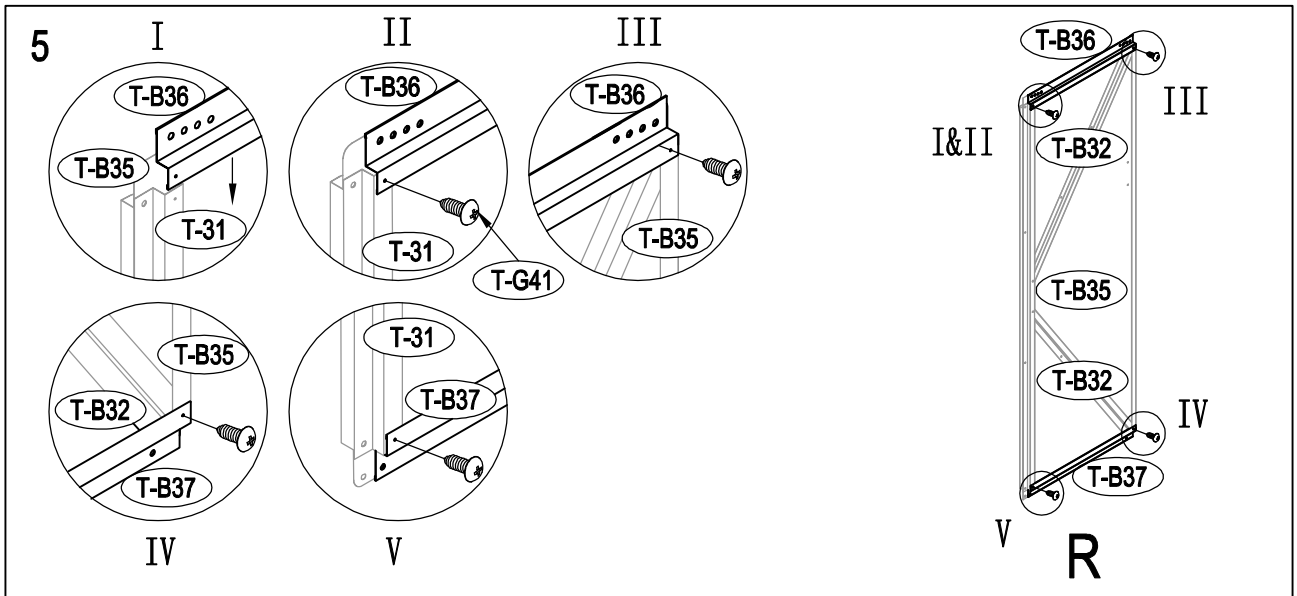
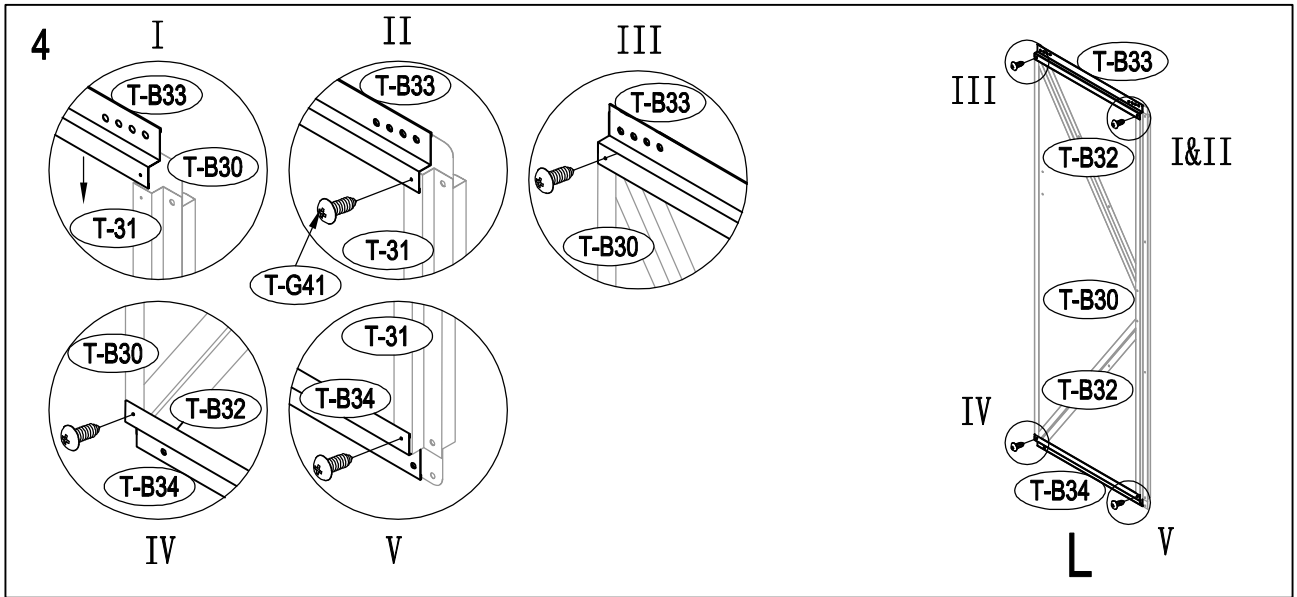

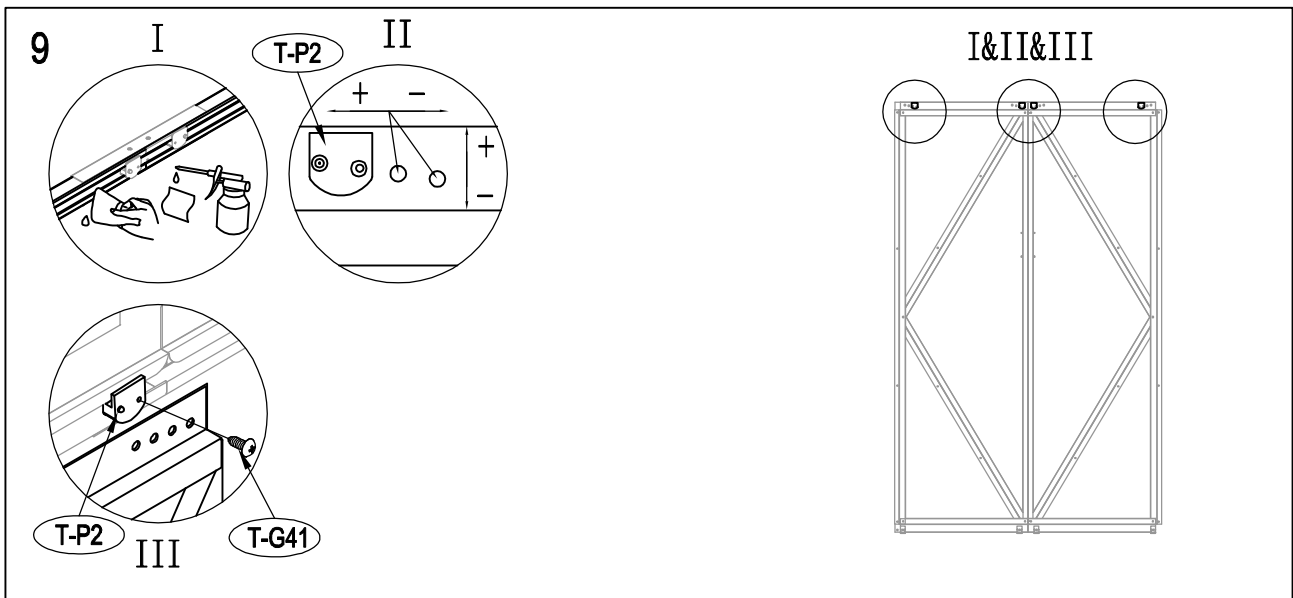
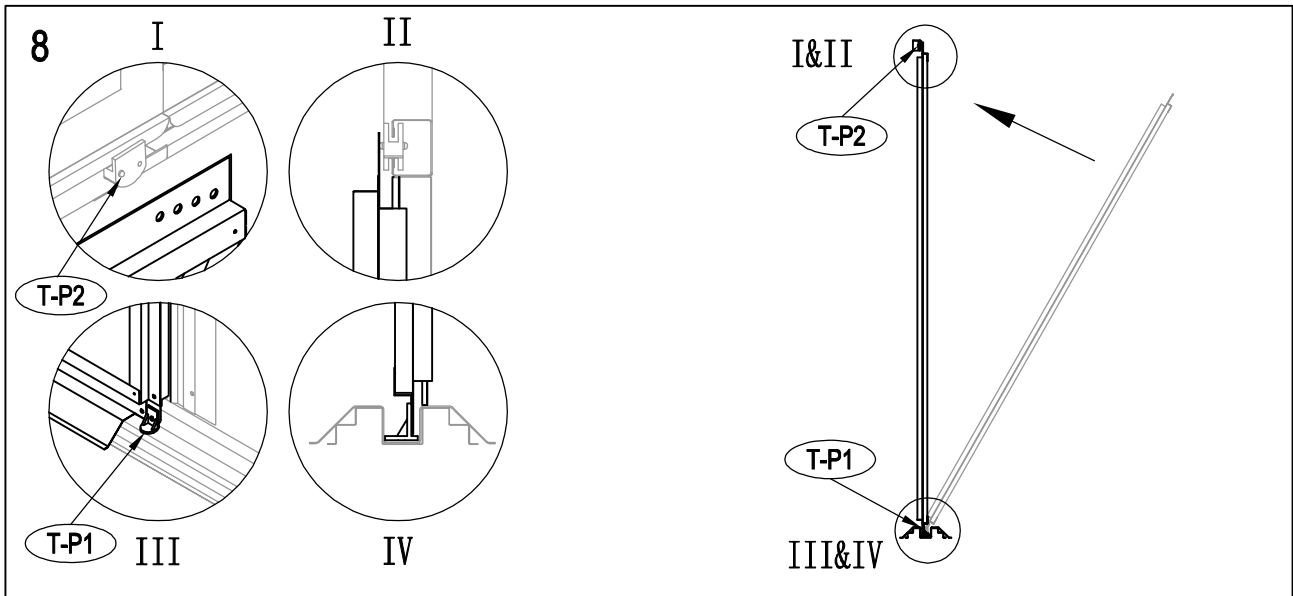
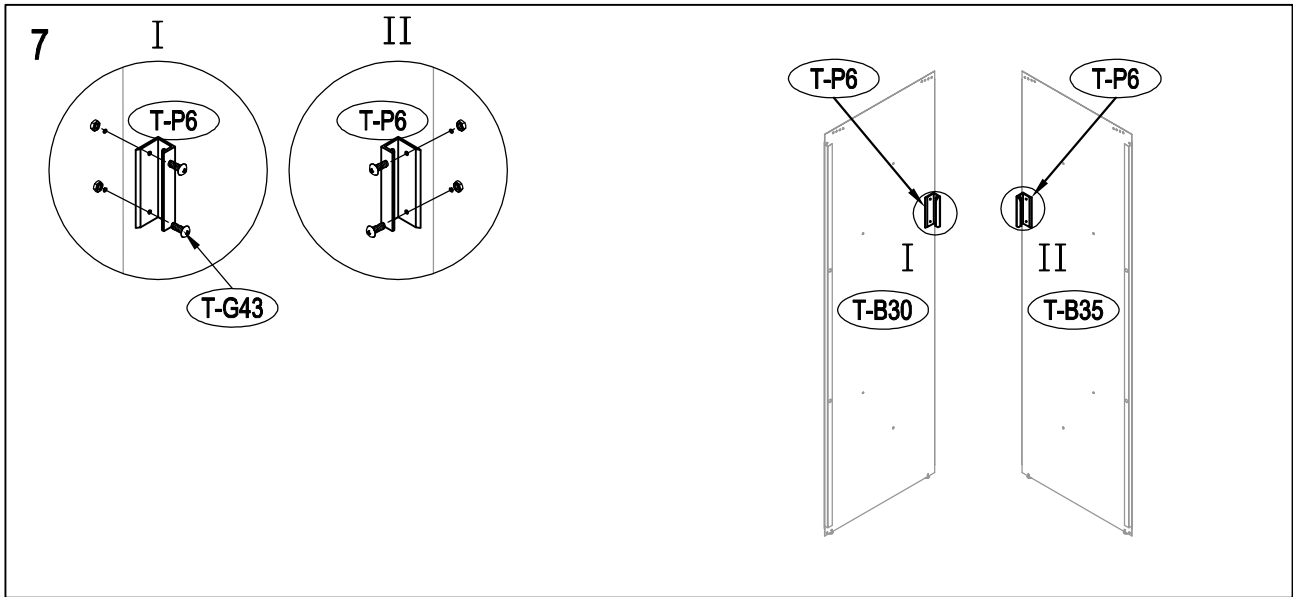

¡Enhorabuena!

Congratulations!

Félicitations !

Parabéns!

Herzliche glückwünsche!

Συγχαρητήρια!

Čestitke!

Čestitamo!

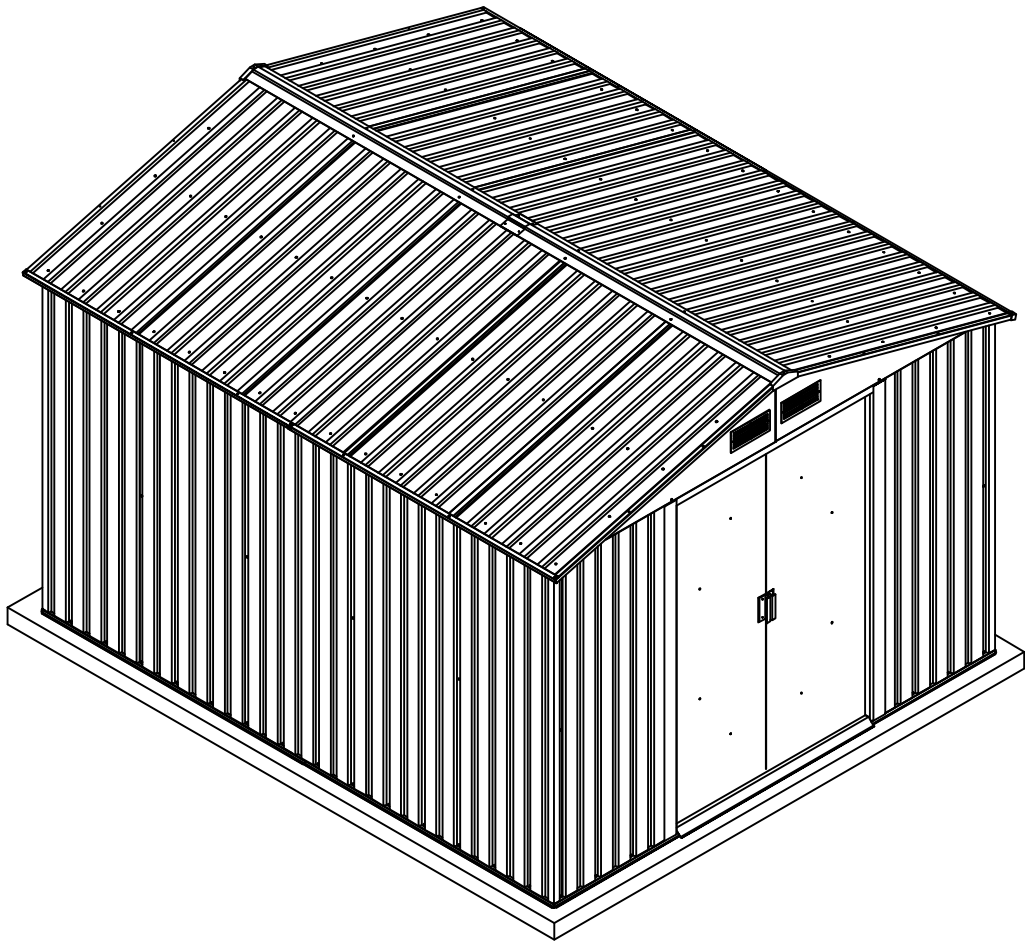

Thank 
you and
congratulations!





 **Hoggar**[®]

... hoggargarden.com



OKORU GLOBAL S.L. // Pol. Ind. Barros nº 29. 39408 Barros. Cantabria - España
(+34) 942 842 170 · info@okoru.es // MADE IN P.R.C.