

CE CE  
EN14428 EN12150

# GME

- ES** Todas las mamparas han sido diseñadas y fabricadas de acuerdo con EN14428  
Todos los cristales utilizados en nuestros productos están certificados y probados de acuerdo con EN12150
- EN** All shower products are designed and manufactured according to EN14428  
All the glass used on the product are certified and tested according to EN12150
- FR** Toutes les parois ont été conçues et fabriquées conformément à EN14428  
Toutes les verres utilisés dans nos produits sont certifiés et testés conformément à EN12150
- IT** Tutti i box doccia sono stati disegnati e fabbricati in accordo con EN14428  
Tutti i cristalli utilizzati nei nostri prodotti sono certificati e collaudati in accordo con EN12150

## MANUAL INSTRUCCIONES

# BASIC



### IMPORTANTE

- ES** La etiqueta de tratamiento antical debe quedar instalada por dentro.  
El acabado de serigrafía por fuera.
- EN** The anti-lime treatment sticker must be installed on the inside.  
The printing glass finish outside.
- FR** L'étiquette de traitement anticalcaire doit rester installée à l'intérieur.  
La finition de la sérigraphie à l'extérieur.
- IT** Il lato in cui è applicata l'etichetta del trattamento anti calcare identifica la parte interna del cristallo.  
Il lato serigrafato va esternamente.

- ES** MANUAL DE INSTALACIÓN  
No tirar. Guardar el manual de instalación para un uso posterior.
- EN** INSTALLATION MANUAL  
Do not discard. Save the installation manual for further use.
- FR** MANUEL D'INSTALLATION  
Ne pas jeter. Garder le manuel d'installation pour un usage ultérieur.
- IT** MANUALE DI INSTALLAZIONE  
Non cestinare. Conservare il manuale di installazione per un utilizzo posteriore.

## GME ATENCIÓN / ATTENTION

- ES** No utilizar productos de limpieza con componentes ácidos en cristales mate serigrafados o cualquier acabado rugoso. Usar solo jabón pH neutro o alcohol.
- EN** Don't use abrasive products or cleaning products with acid components in print silted glasses or any rugged decoration. Use normal pH neutral soap or alcohol.
- FR** Ne pas utiliser de produits de nettoyage avec des composés acides dans les verres mate sérigraphiés ou n'importe quel finition rugueuse. Utiliser uniquement savon pH neutre ou alcool.
- IT** Non usare prodotti di igiene con componenti acidi su cristalli opachi, serigrafati o con qualunque finitura rugosa. Utilizzare unicamente saponi pH neutro o alcool.



- ES** Vinagre / Antical / Desengrasante
- EN** Vinegar / Anti-lime / Detergent
- FR** Vinaigre / Anticalcaire / Détérgent
- IT** Aceto / Anti calcare / Detergente



- ES** Jabón pH neutro / Alcohol
- EN** pH neutral soap / Alcohol
- FR** Savon pH neutre / alcool
- IT** Sapone pH neutro / Alcool



## IMPORTANT INFORMATION / INFORMACIÓN IMPORTANTE / INFORMATIONS IMPORTANTES / INFORMAZIONI IMPORTANTI

- EN** • Always wear safety goggles and work gloves when installing or disassembling this product, especially when working with glass panels.
- When handling, never rest the corner of the glass directly on the floor or hit the corner with any object. This can cause the glass to break.
- Always have two persons to install or disassemble the shower.
- Small children should never use the shower unsupervised or without proper instructions for safety use.
- Small children should never hit, lean, or hang on the shower product. Nor should they do any inappropriate activity in the vicinity of the shower.
- Tempered safety glass is designed to shatter into small tiny pieces when the glass is broken, this is to avoid serious injury.
- ES** • Llevar gafas y guantes de seguridad durante la instalación o desmontaje de este producto, especialmente durante la manipulación de los cristales
- Durante la manipulación, nunca dejar descansar las esquinas de los cristales directamente en el suelo o golpearlos con cualquier objeto. Puede provocar la rotura del cristal
- Es conveniente que la instalación o el desmontaje sea llevado a cabo por dos personas.
- Los niños no deben usar la ducha sin supervisión o sin apropiadas instrucciones de uso para sus seguridad
- Los niños no deben, bajo ningún concepto, golpear, apoyarse o colgarse de los productos de ducha. De la misma manera, deberán realizar actividades inapropiadas en las inmediaciones de la mampara.
- El cristal templado de seguridad ha sido diseñado para romper en pequeñas piezas con el objetivo de evitar daños mayores
- FR** • Porter des lunettes et des gants de sécurité aux cours de l'installation de ce produit, en particulier pendant la manipulation des verres.
- Pendant la manipulation ne jamais laisser reposer les coins des verres directement par terre ou les choquer avec n'importe quel objet. Cela peut provoquer la brisure du verre.
- Il est souhaitable que l'installation ou le déballage soit réalisé par deux personnes.
- Les enfants ne doivent pas, en aucun cas, choquer, s'appuyer ou se pendre des produits de douche. De la même manière ils ne devront pas réaliser des activités inappropriées à proximité de la paroi.
- Le verre trempé de sécurité a été conçu pour casser en petites pièces afin d'éviter de plus grands dommages.
- IT** • Indossare occhiali e guanti protettivi durante l'installazione o smontaggio di questo prodotto, specialmente durante la manipolazione dei cristalli.
- Non appoggiare mai gli angoli dei cristalli direttamente al suolo o colpirli con qualunque oggetto durante la manipolazione. Il cristallo potrebbe rompersi.
- È conveniente che l'installazione o lo smontaggio siano eseguiti da due persone contemporaneamente.
- I bambini non devono usare la doccia senza la supervisione di un adulto o senza le dovute istruzioni di sicurezza
- I bambini non devono colpire, appoggiarsi o appendersi agli elementi della doccia. Non dovranno, inoltre, realizzare attività inappropriate in prossimità del box doccia.
- Il cristallo temperato di sicurezza è stato disegnato affinché si rompa in piccoli pezzi onde evitare danni maggiori.

## Body part / Despiece

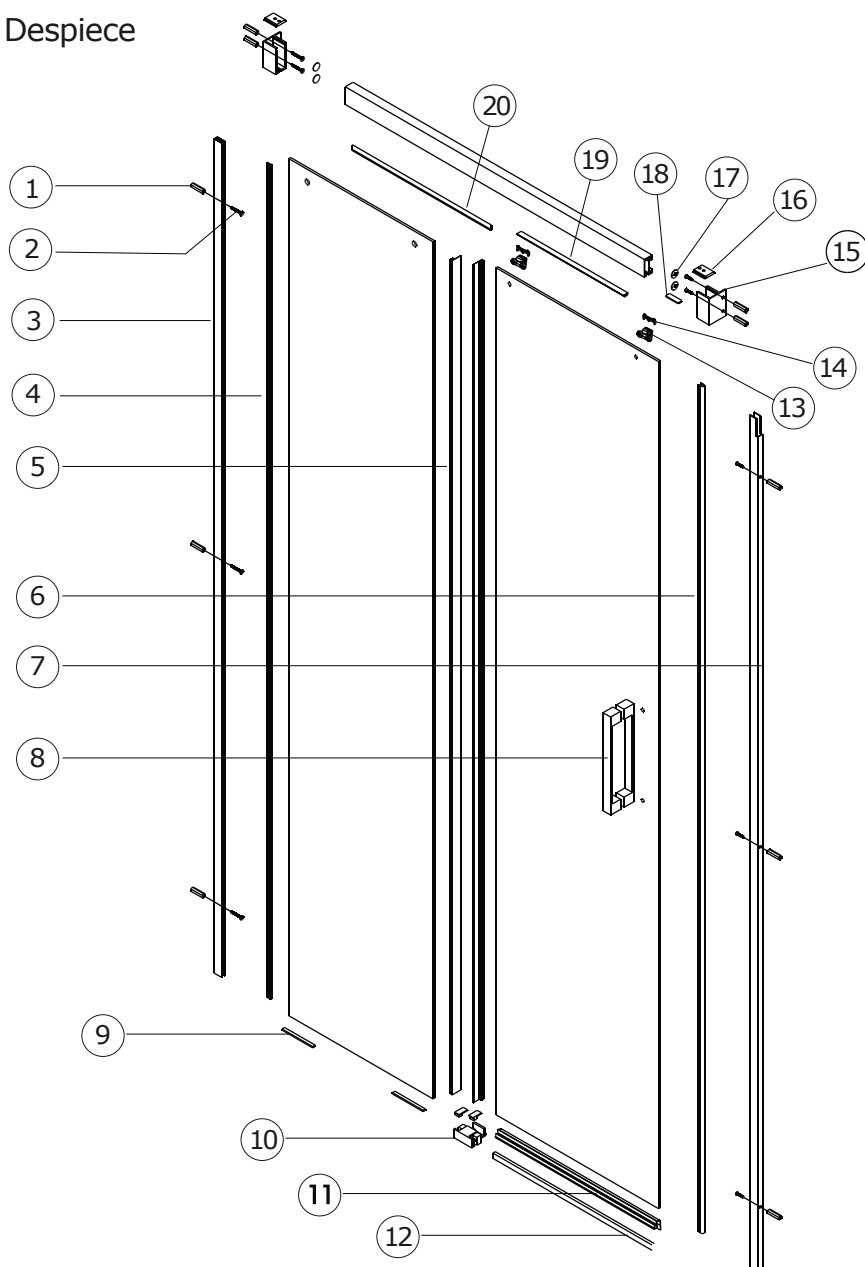

## Tools / Herramientas

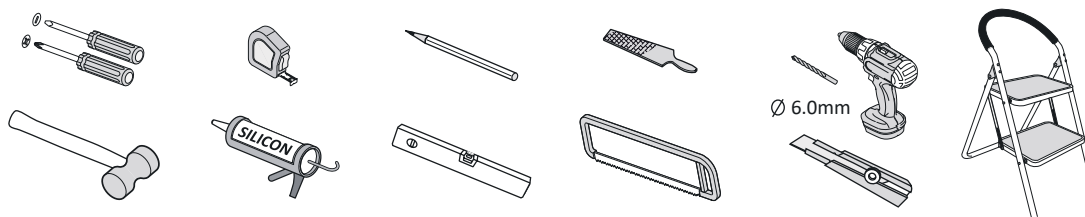

## Hardware list / Lista accesorios

Num. Number	Imagen Pic	Cant. Qty.	Num. Number	Imagen Pic	Cant. Qty.	Num. Number	Imagen Pic	Cant. Qty.	Num. Number	Imagen Pic	Cant. Qty.
1		10	6		1	11		1	16		2
2		10	7		1	12		1	17		4
3		1	8		1	13		2	18		1
4		1	9		1	14		2	19		1
5		2	10		1	15		LR/1	20		1

## Installation in bathtub / Instalación en bañera

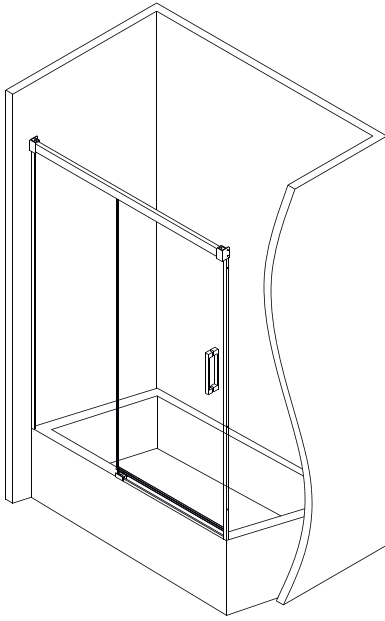

-Cortar 45cm los perfiles 3 y 7 en la parte inferior y adaptar las gomas 4, 5 y 6.

-Cut 45 cm profiles 3 and 7 from the bottom and adapt the rubber bands 4, 5 and 6.

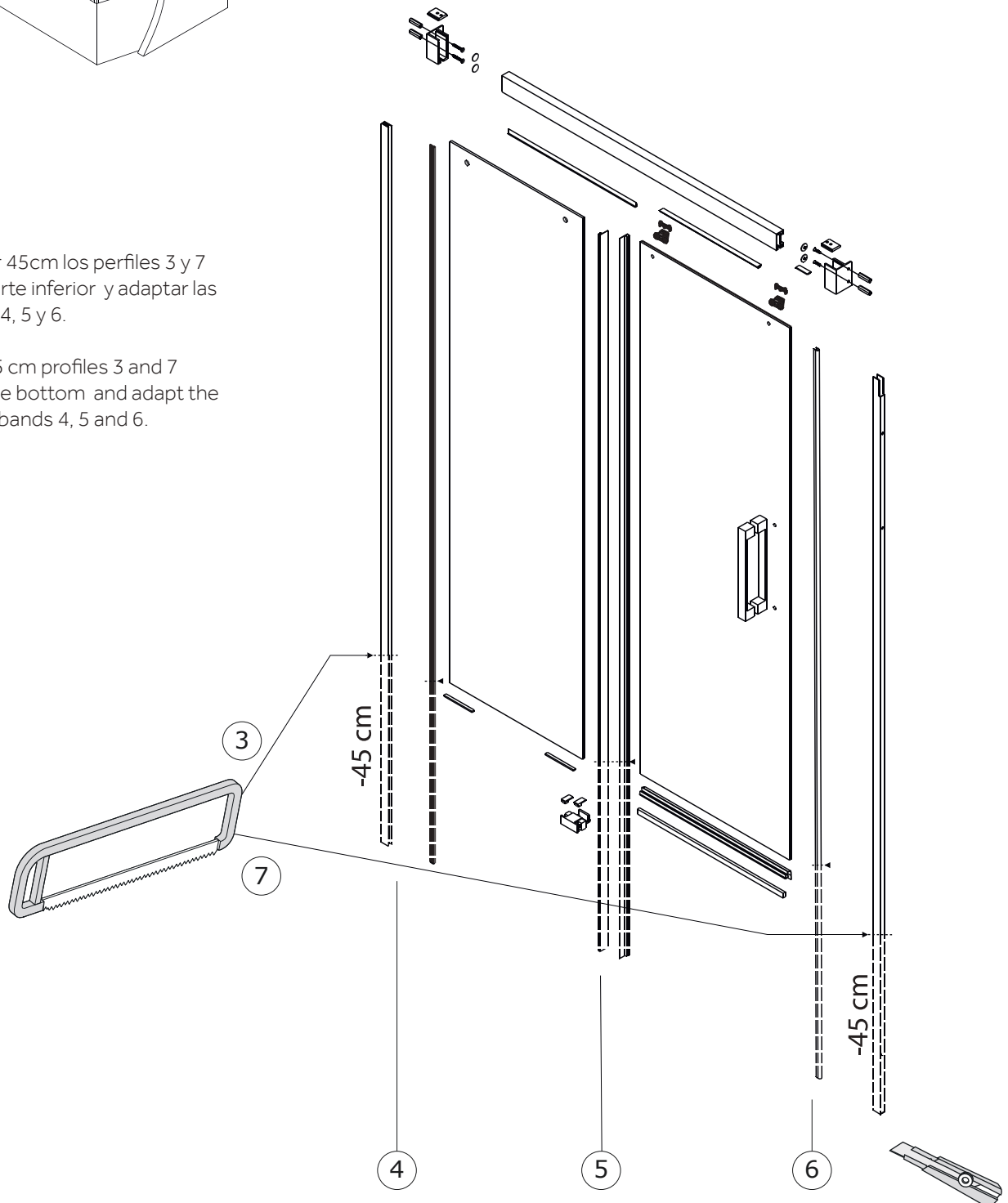

1

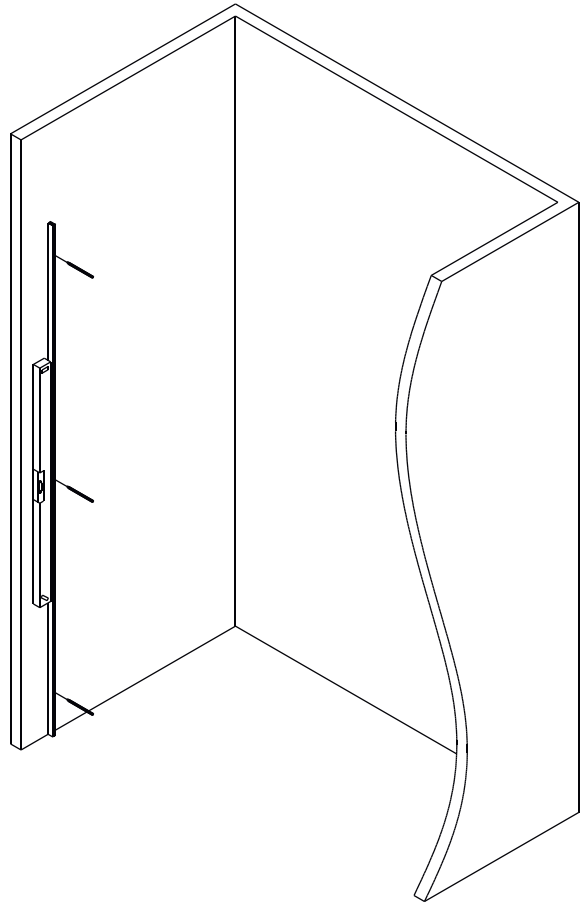

2

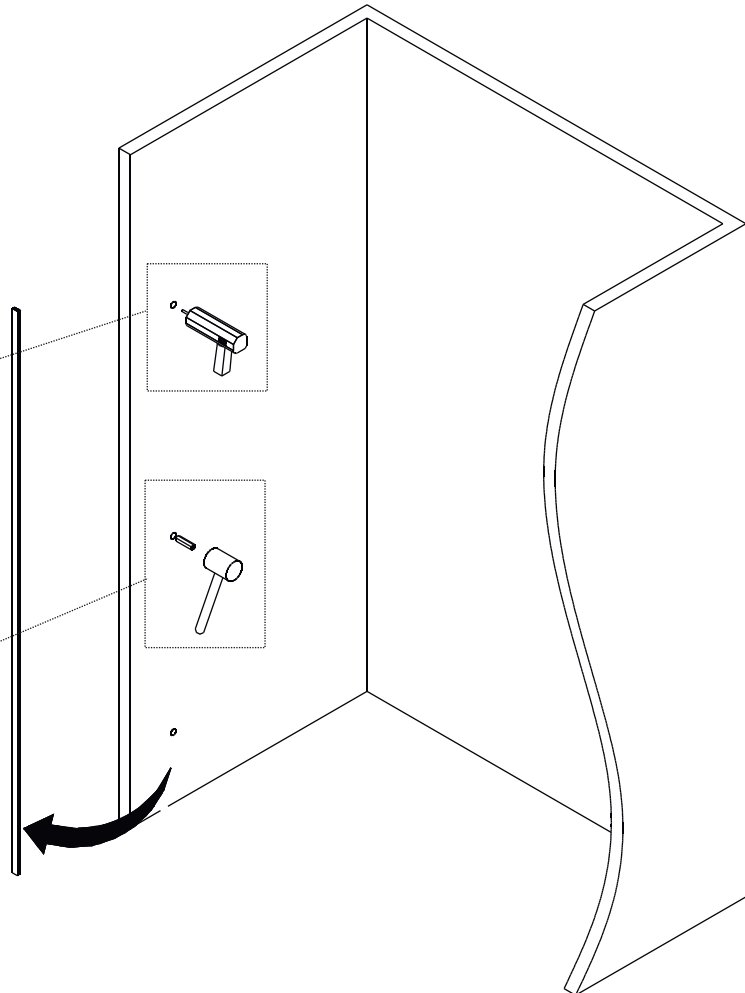
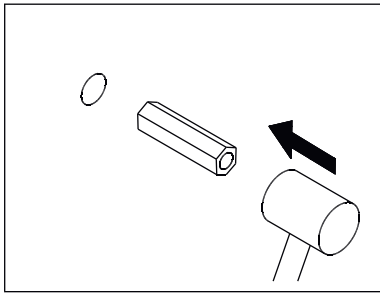
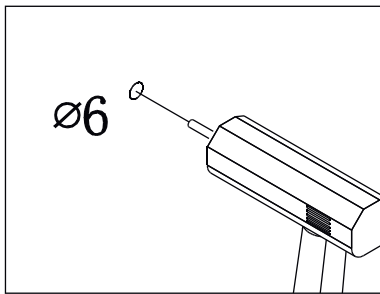

3

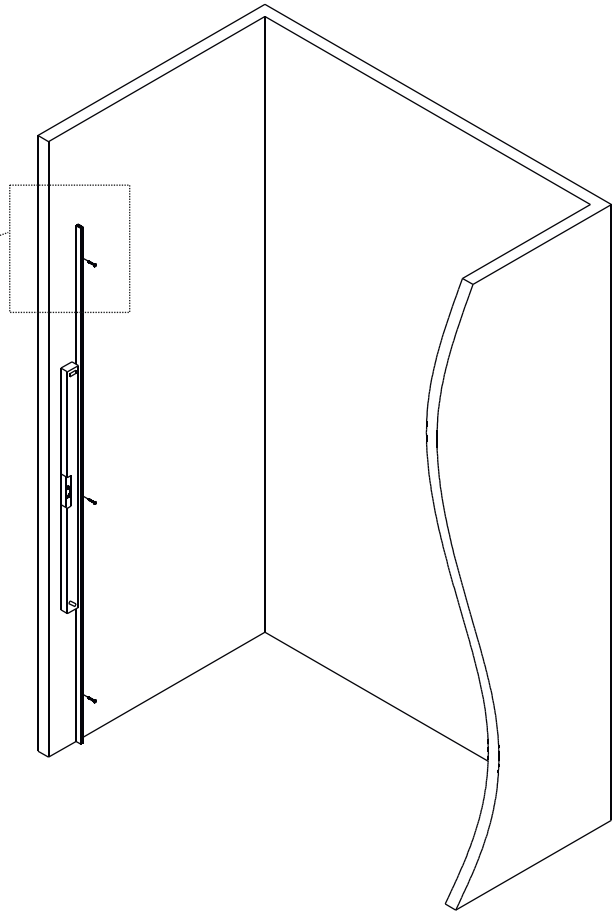
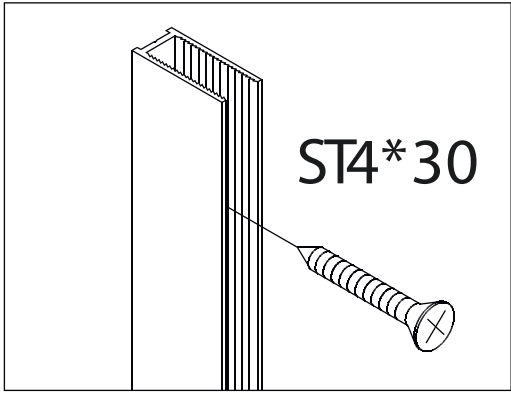

4

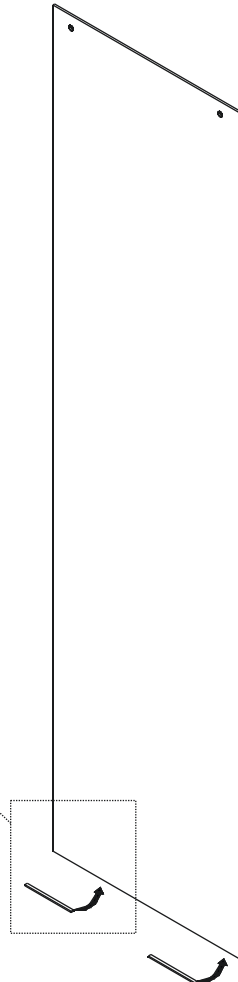
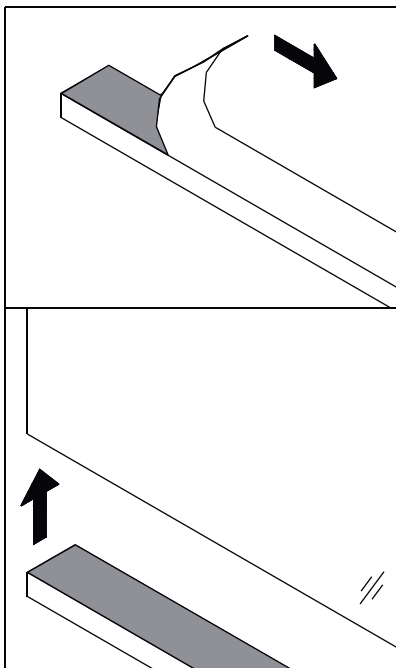

5

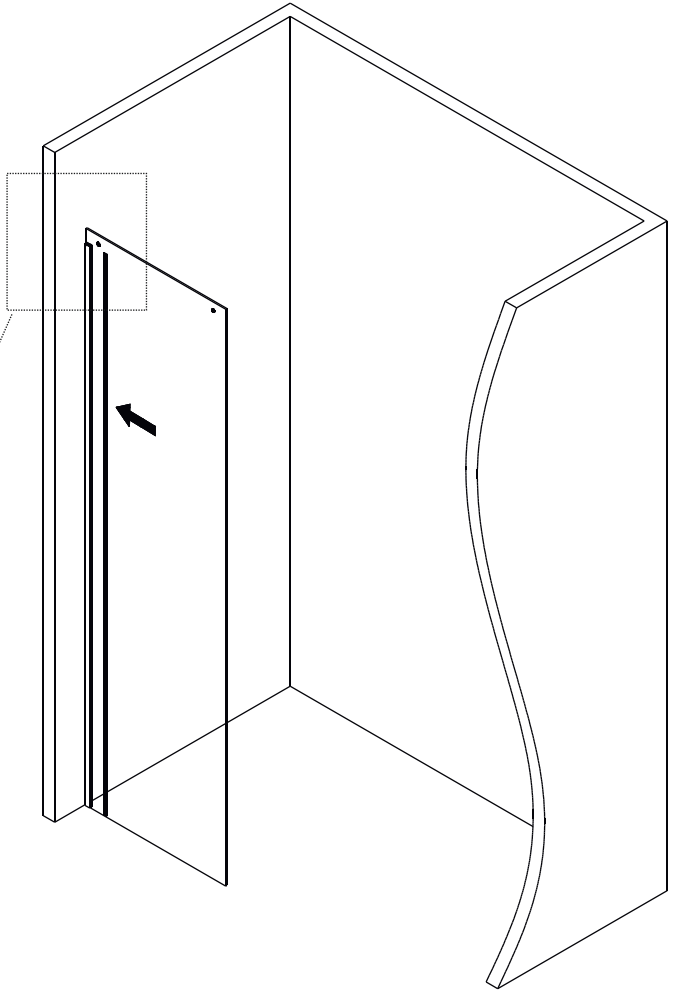
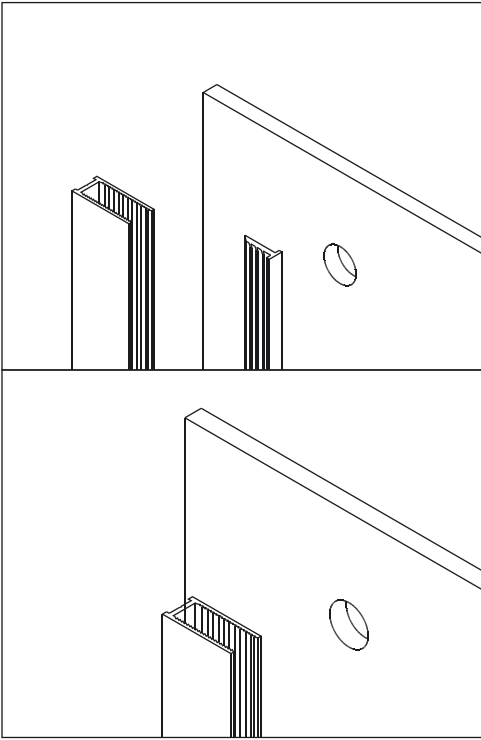

6

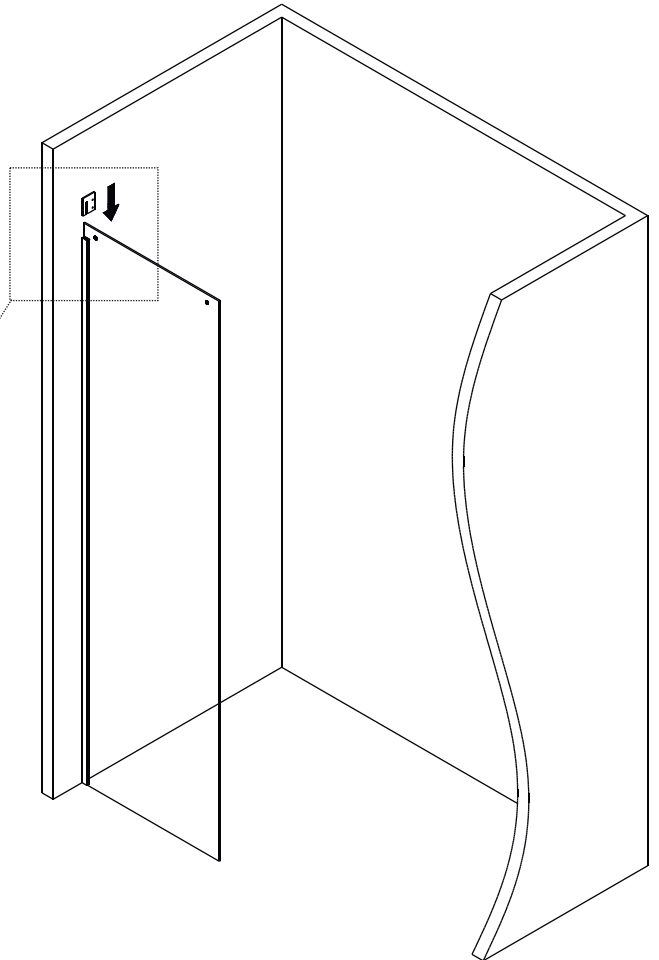
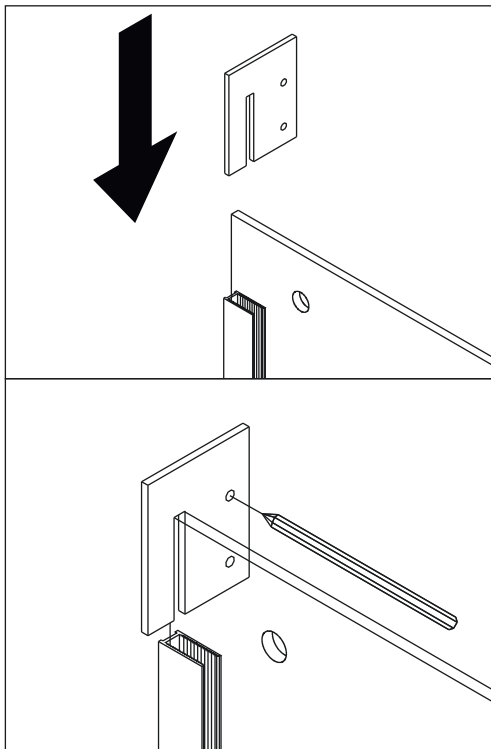

7

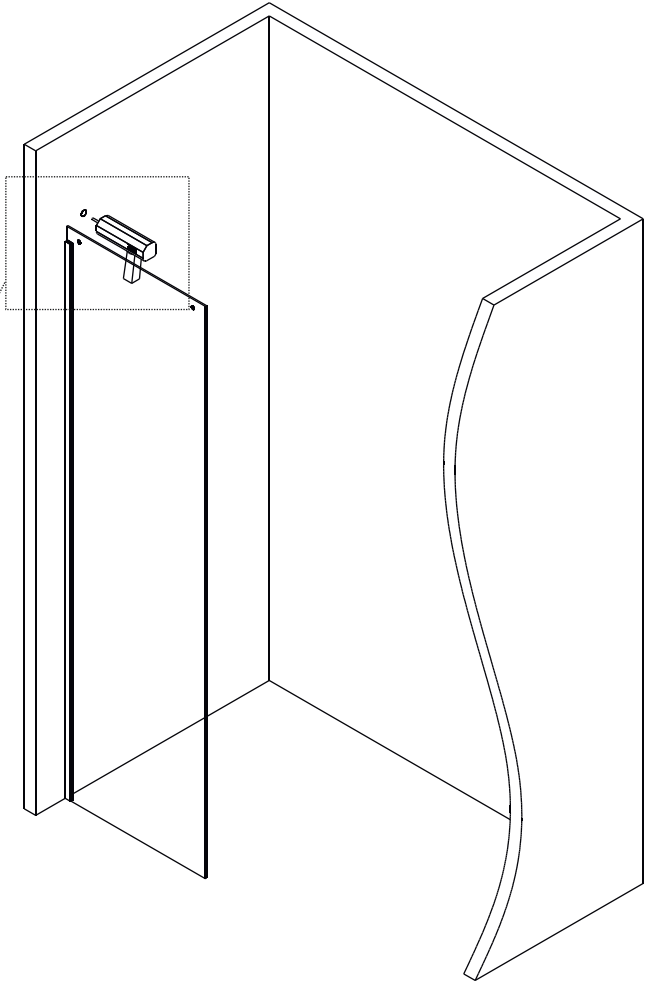
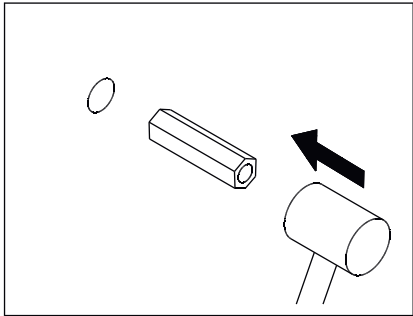
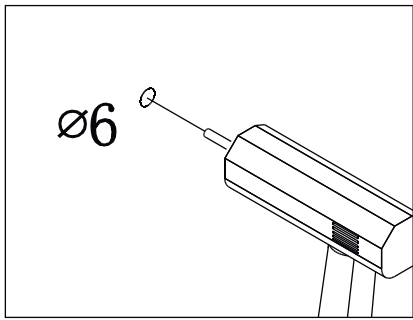

8

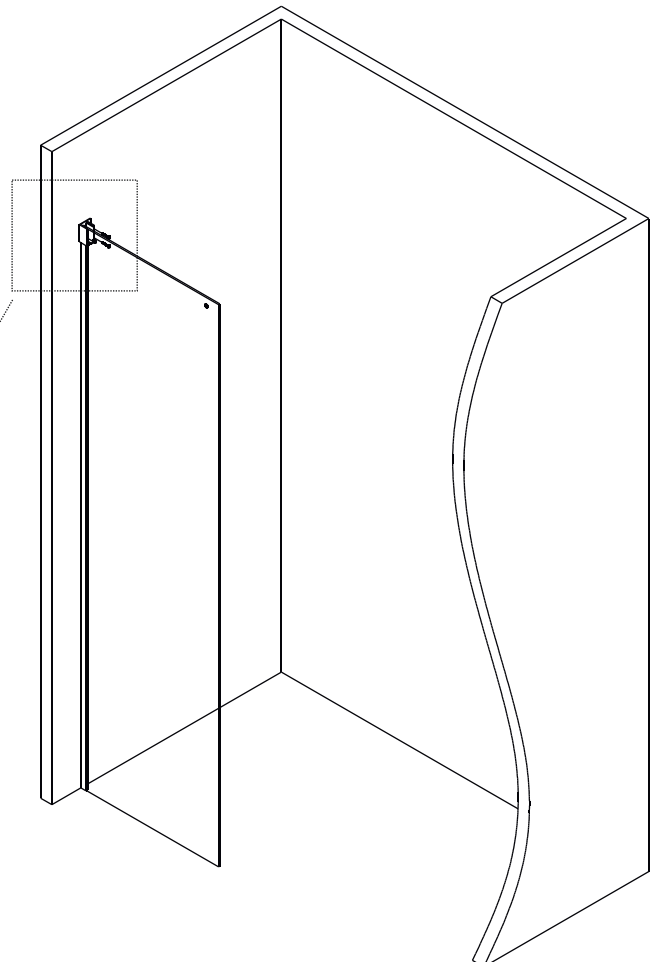
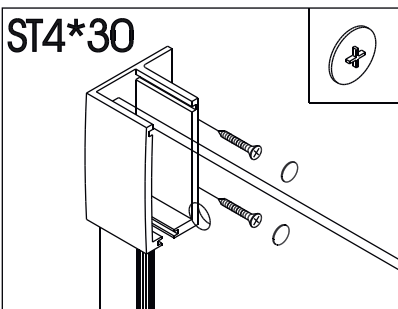
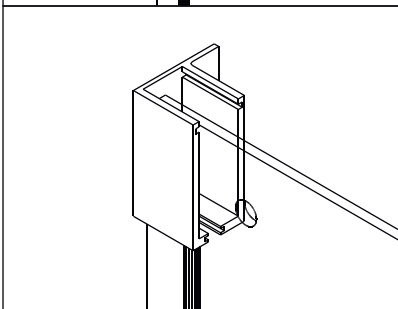
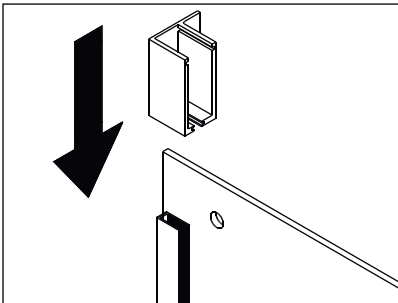



9

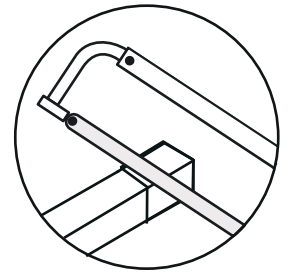
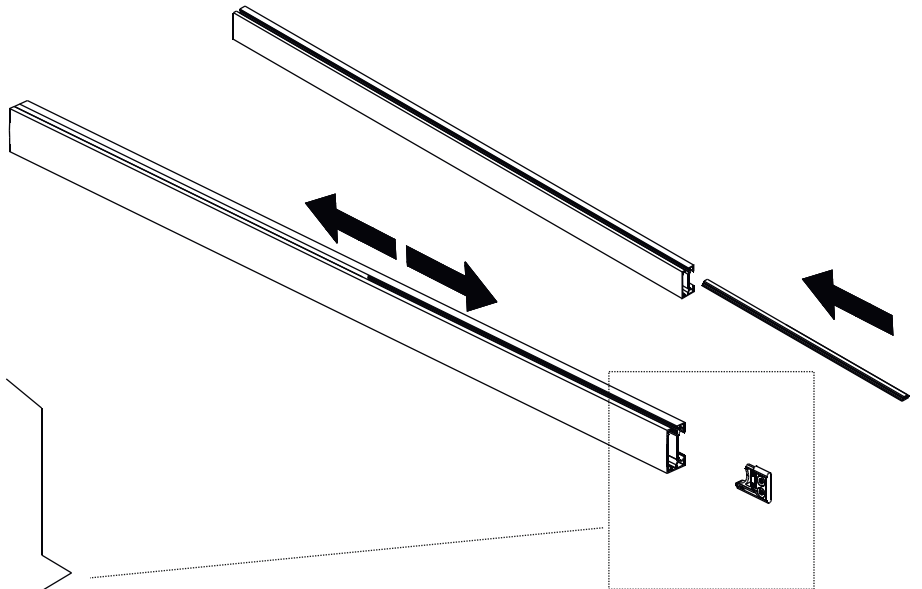
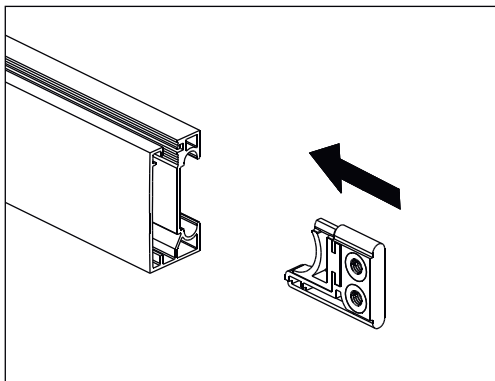
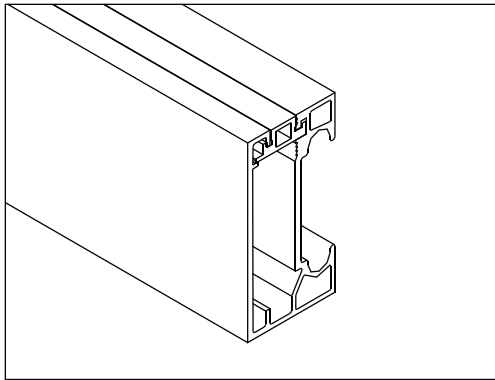

10

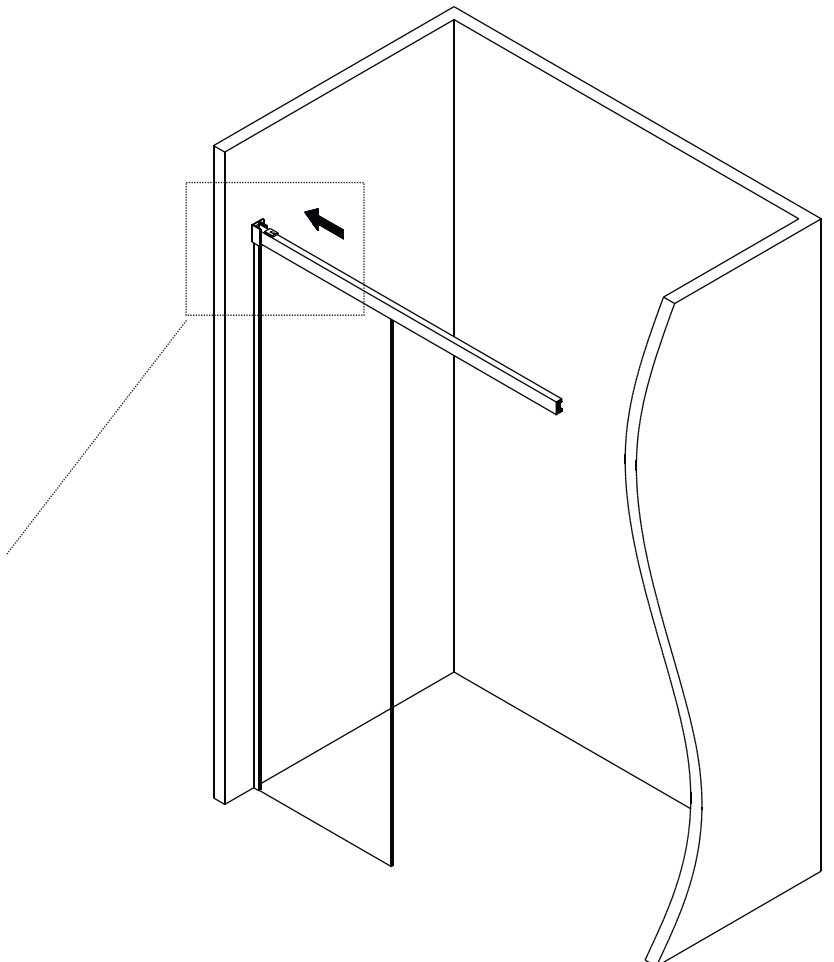
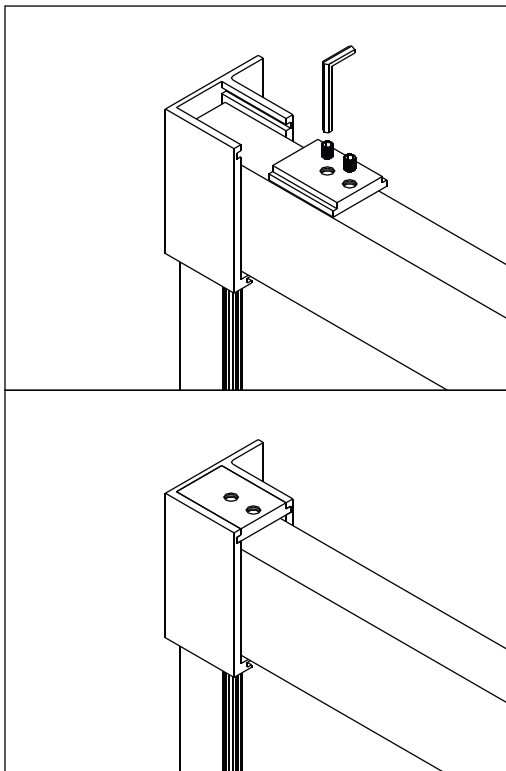

11

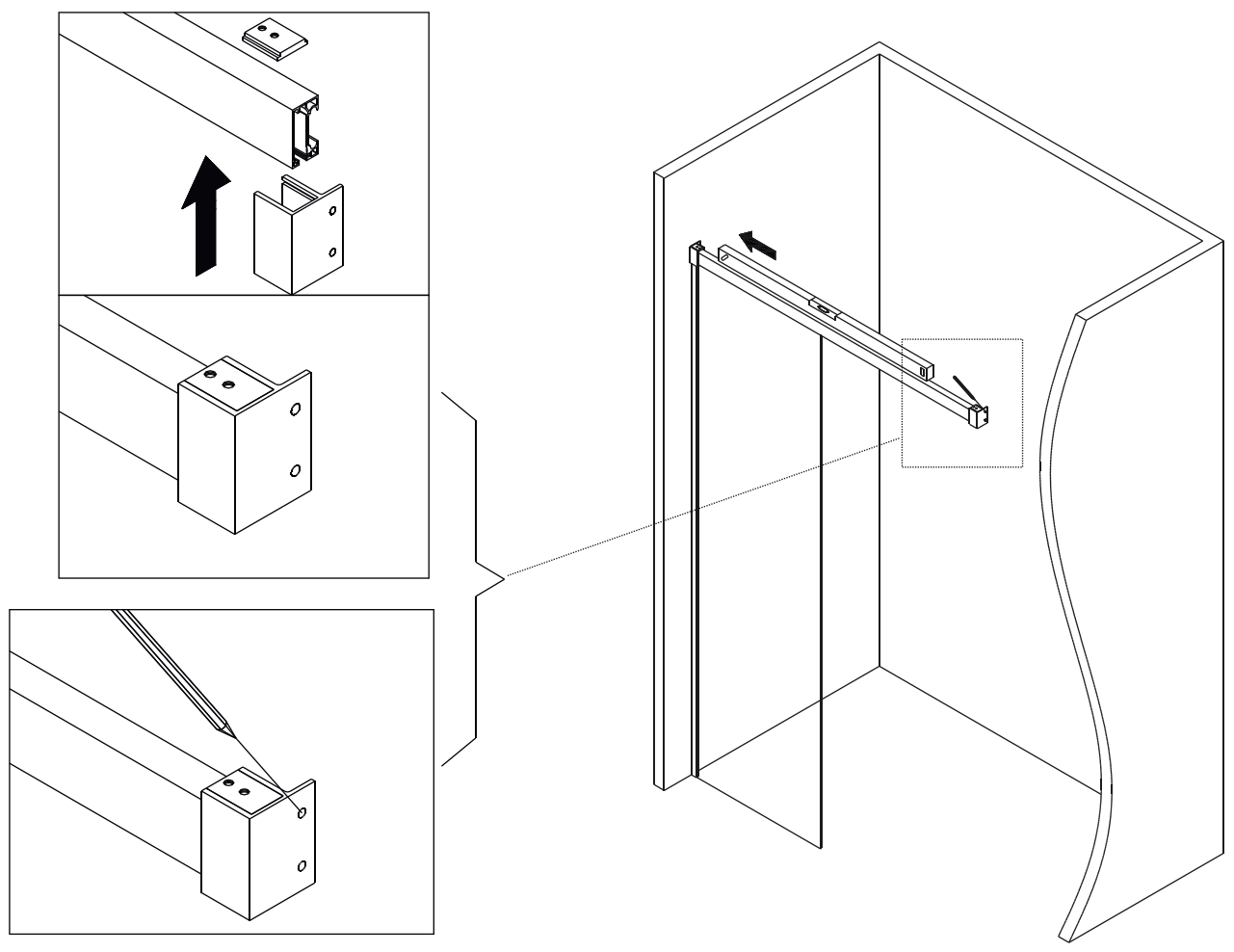

12

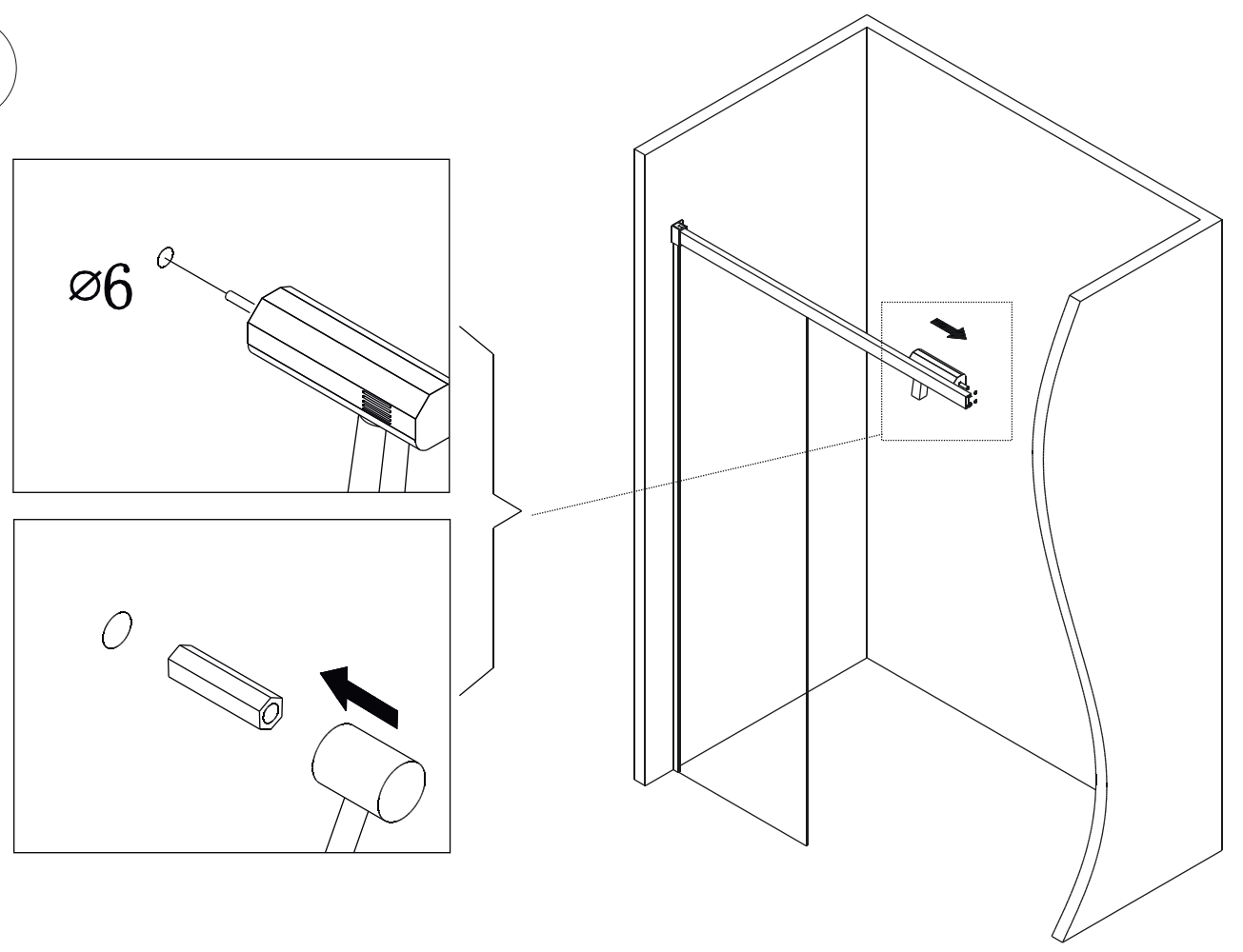

13

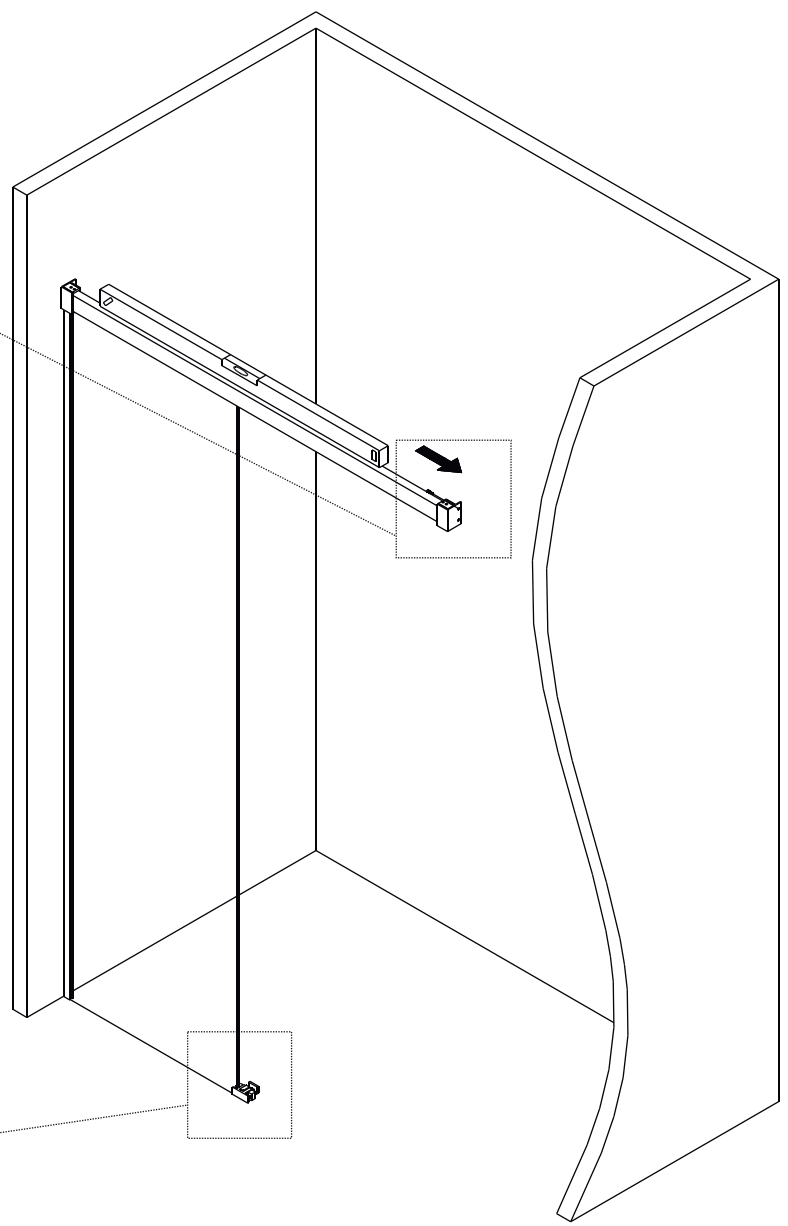
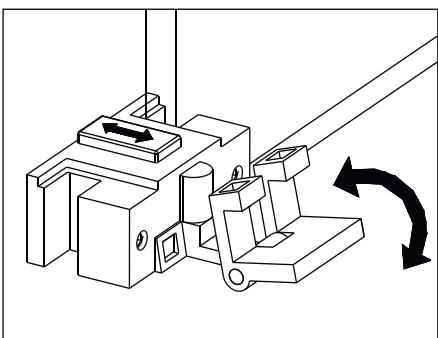
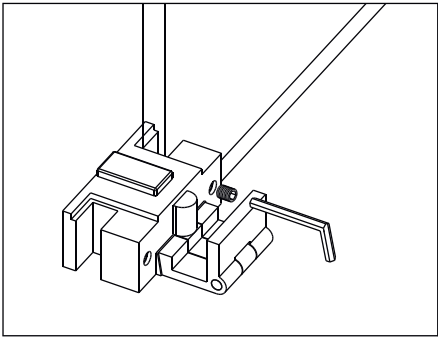
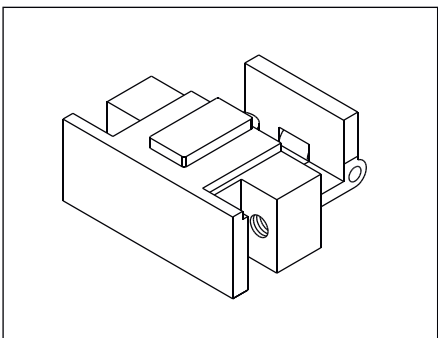
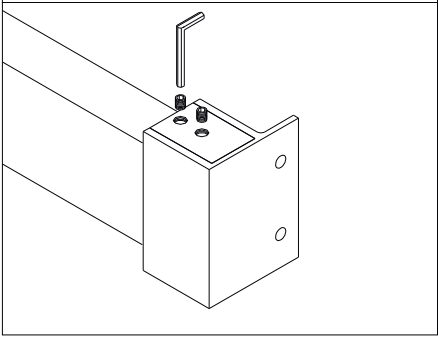
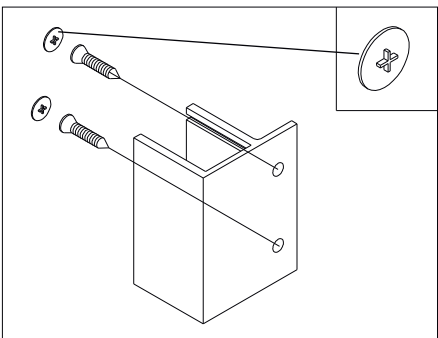

14

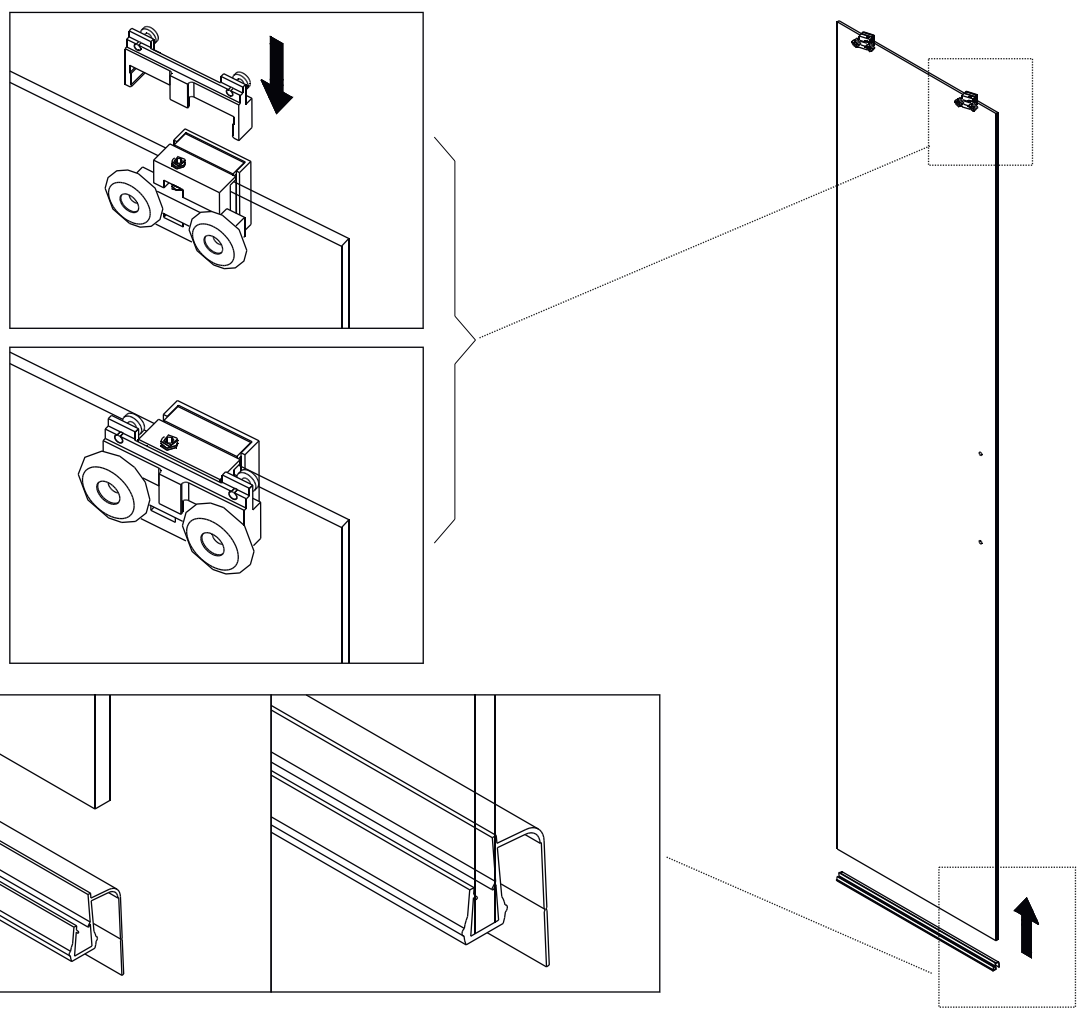

15

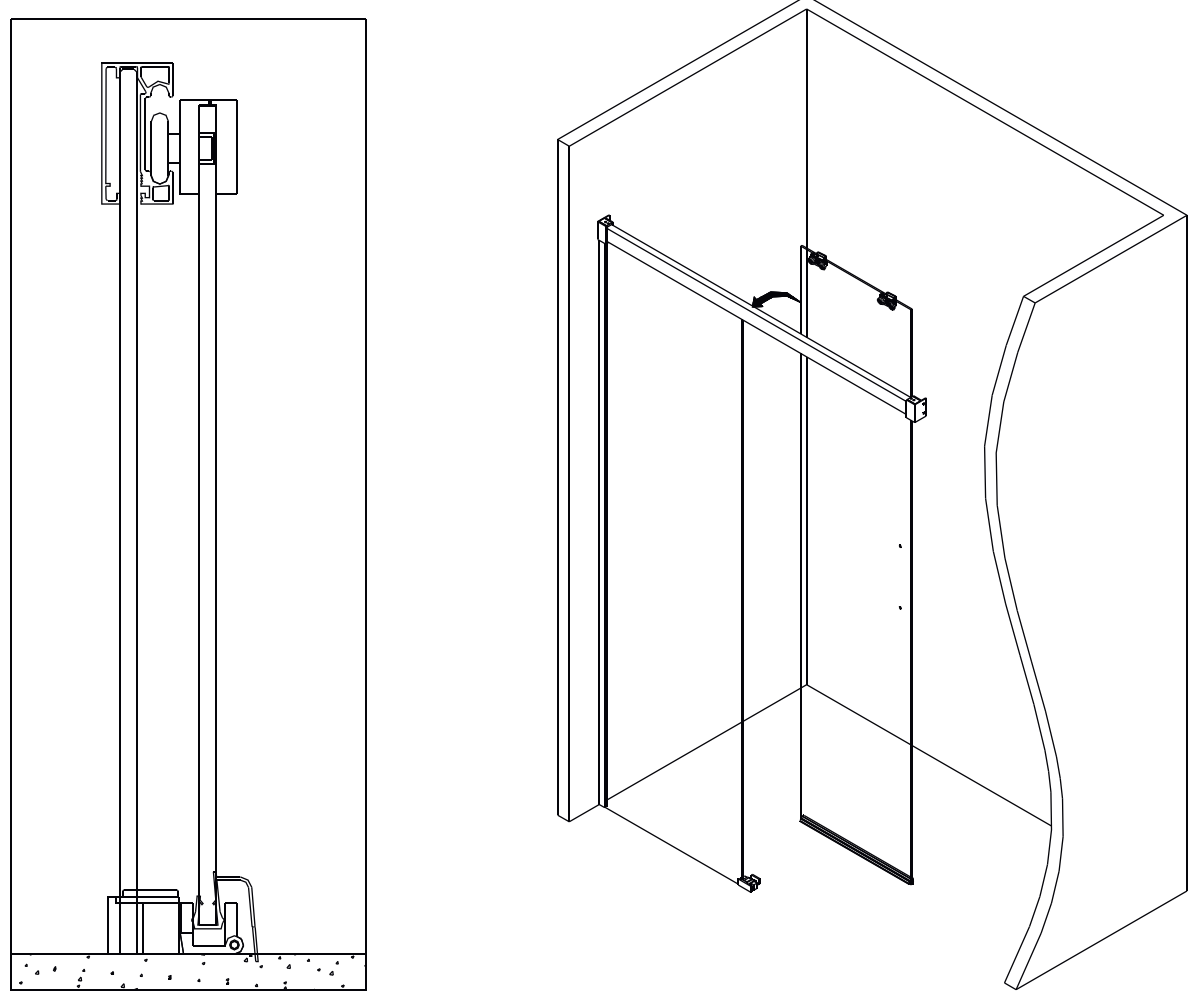

16

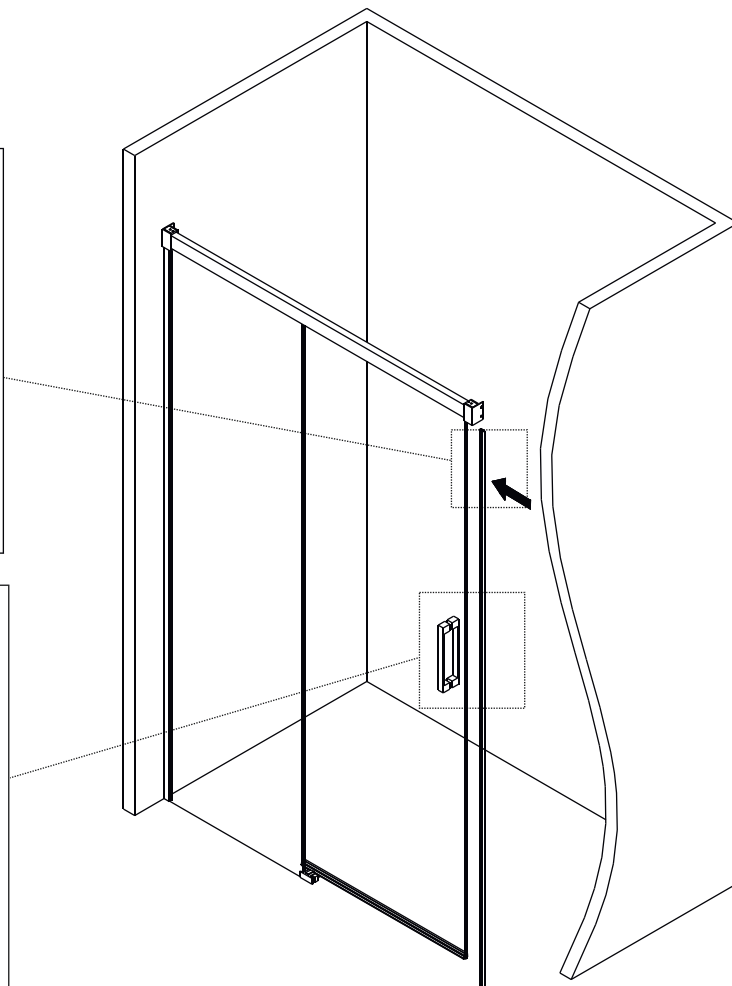
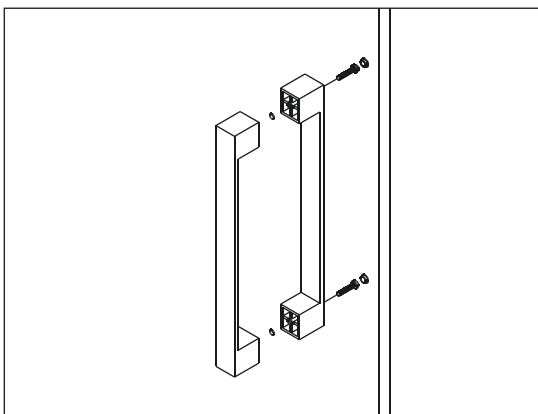
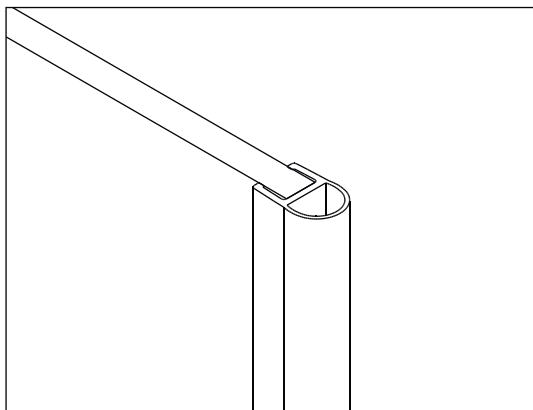

17

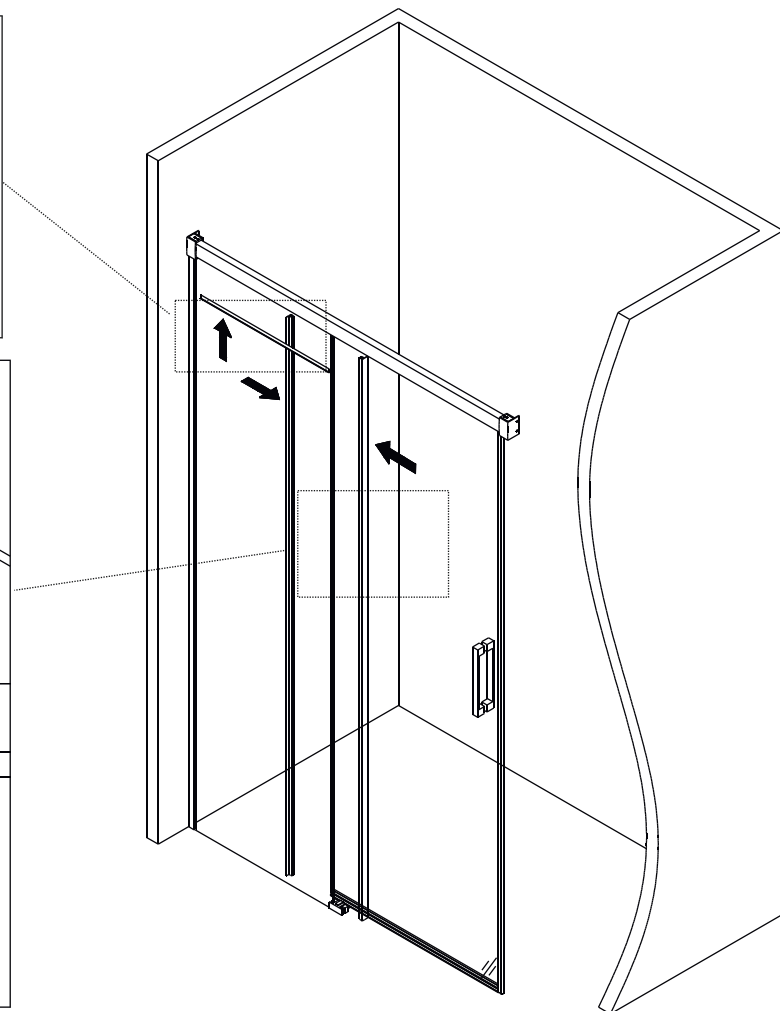
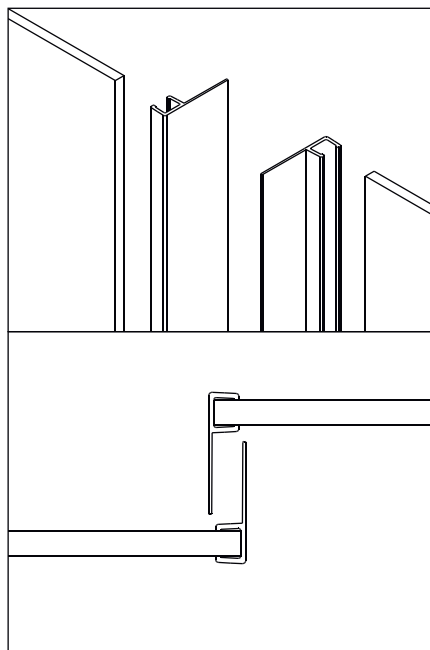
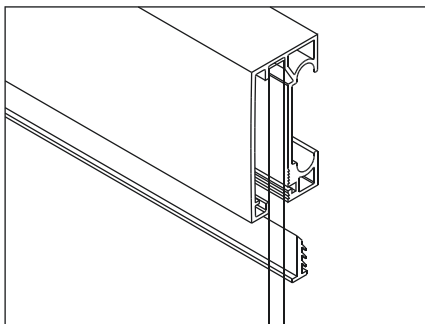

18

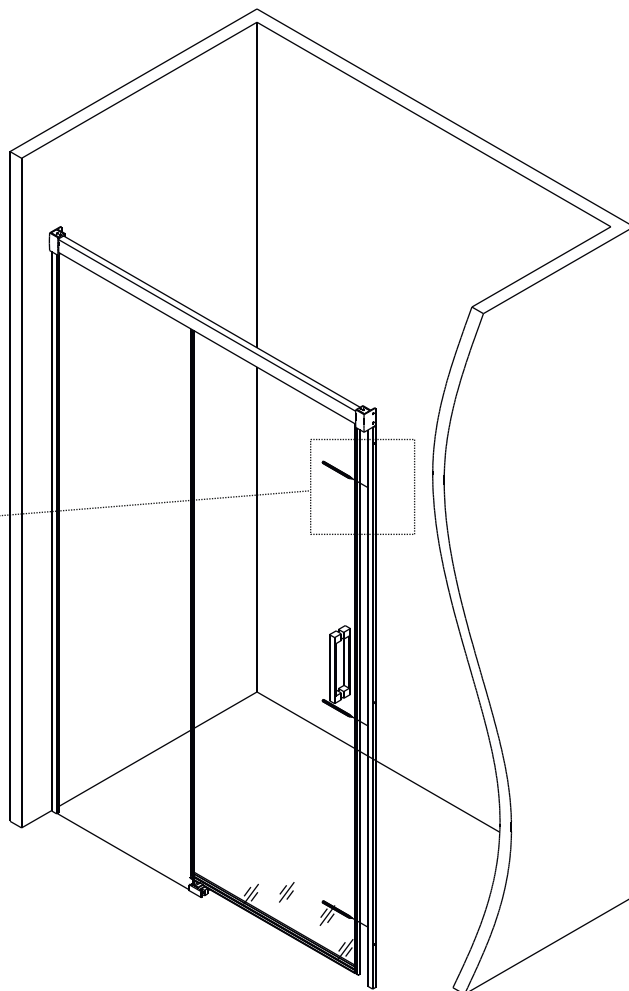
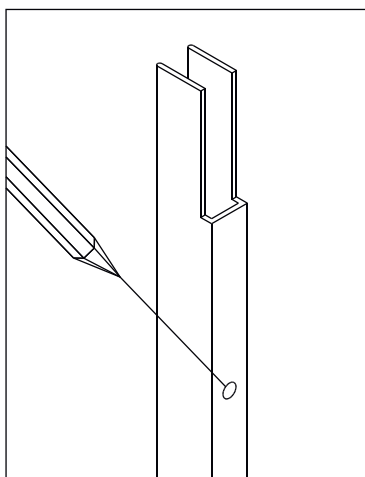
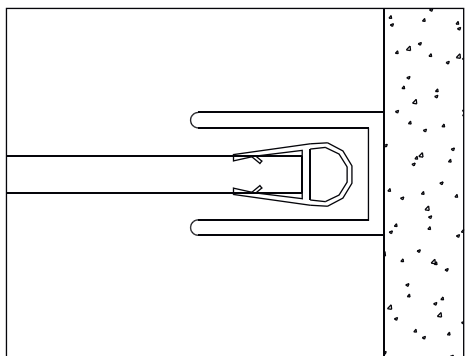

19

ST4\*30

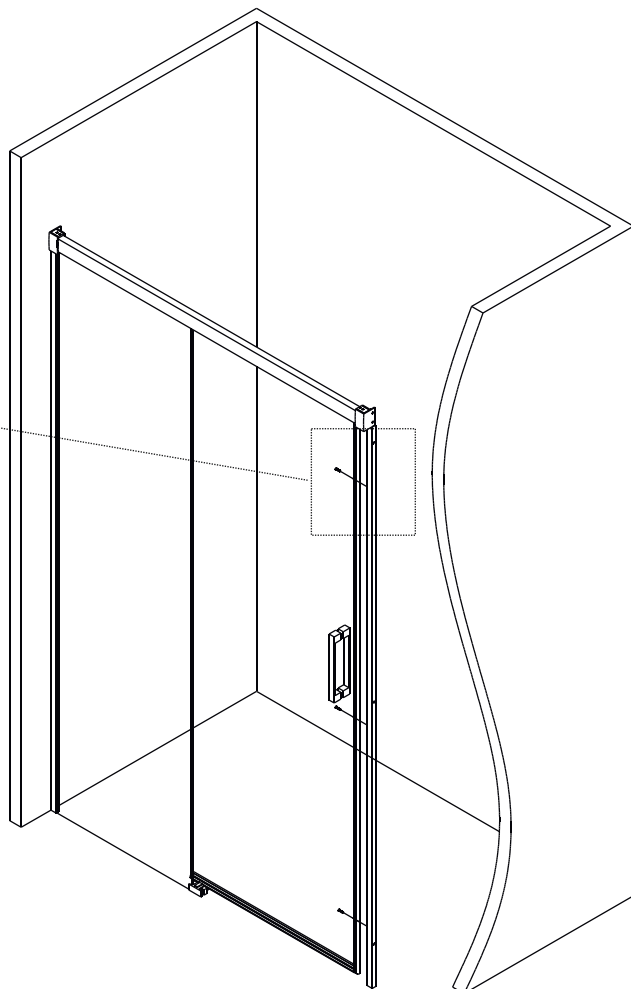
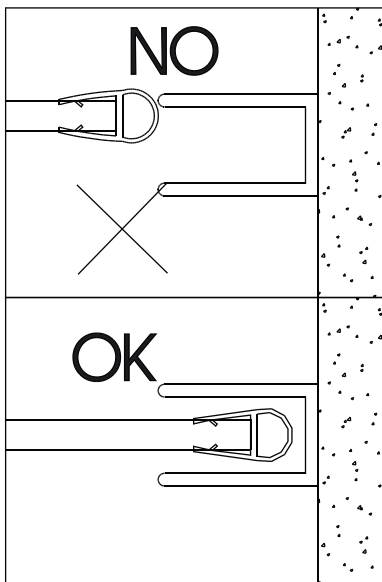
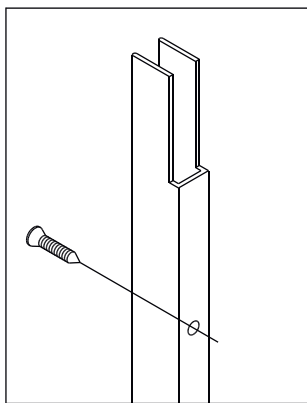

20

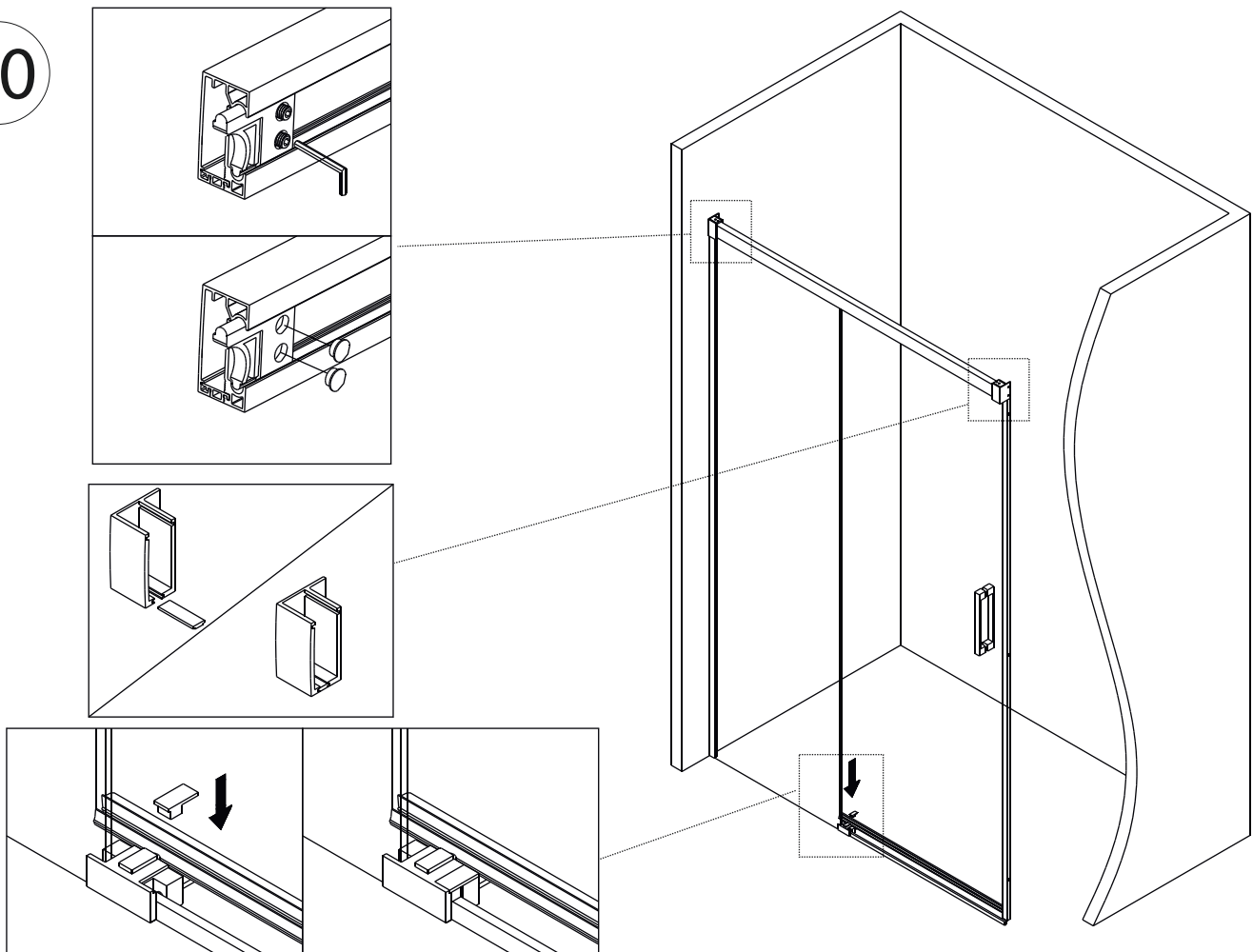

21

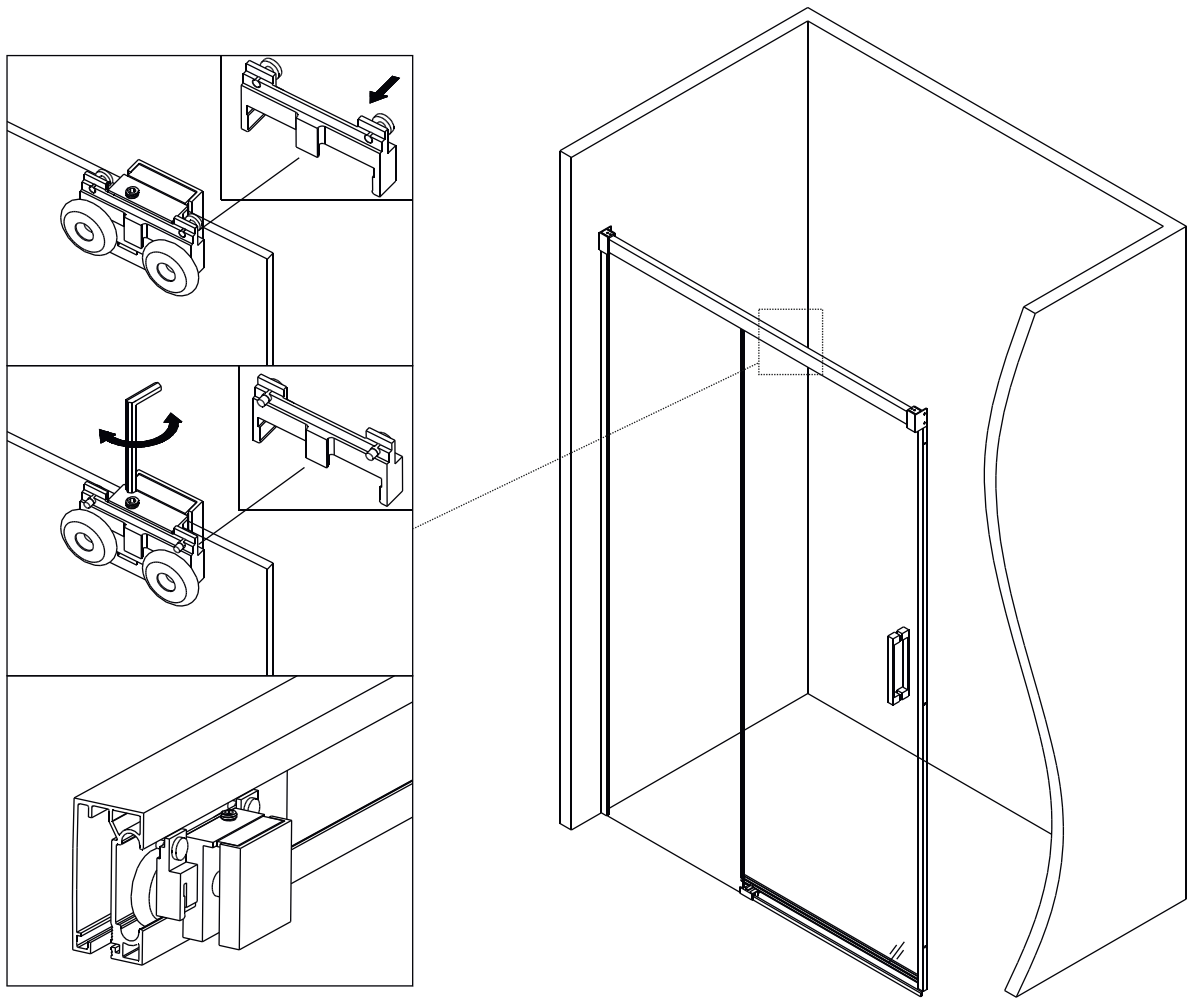

22

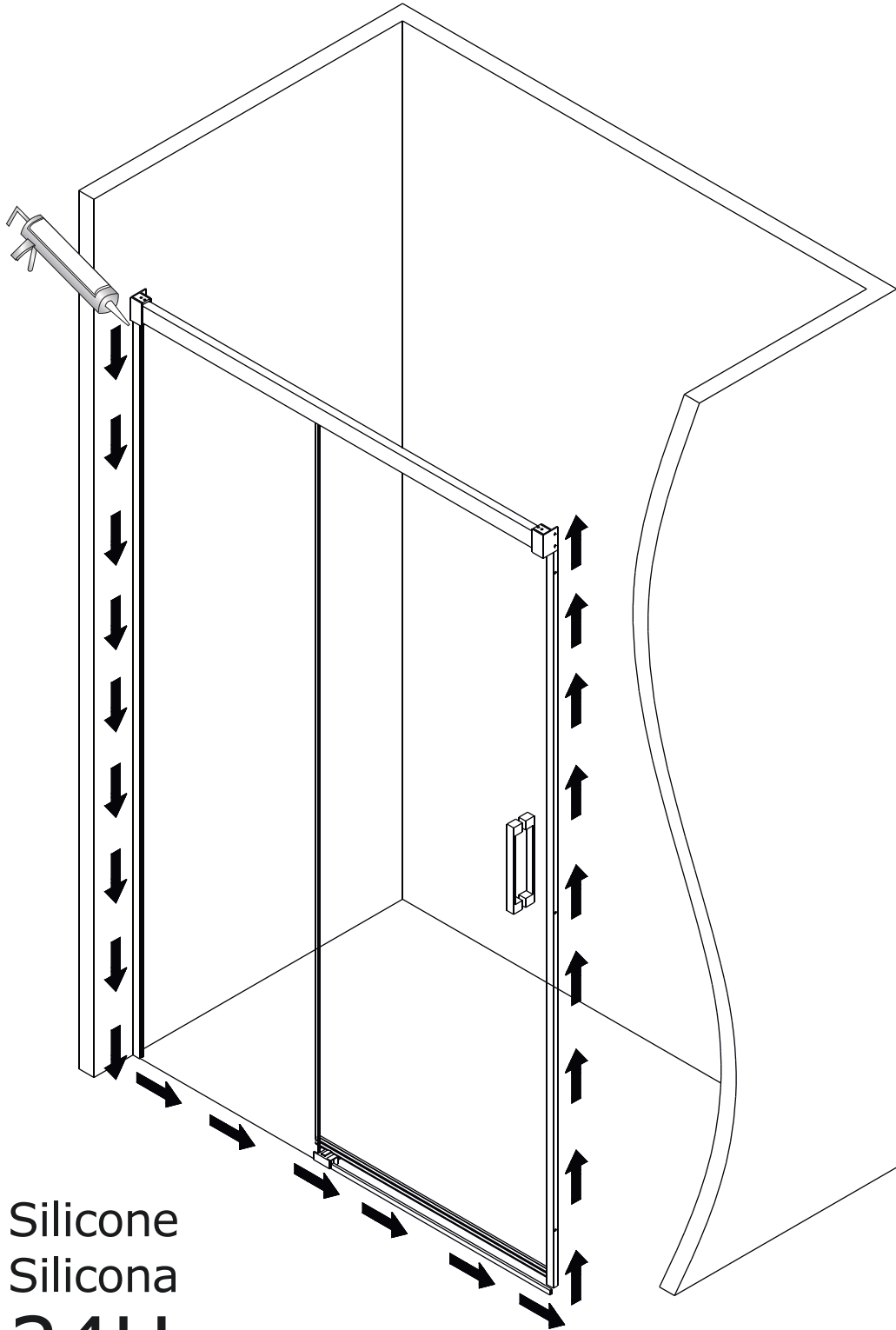

Silicone  
Silicona  
**24H**



GME DIVISION BAÑOS S.L.  
C\Pinadeta 16  
Pq. Ciudad de Mudeco  
46930 - Quart Poblet  
(Valencia) - España

telf. 00 34 96 252 18 55  
fax 00 34 96 252 18 56  
info@gmelorente.com  
www.gmelorente.com

**GME**  
DIVISIÓ**N** BAÑOS