

POWERPLUS
HIGH QUALITY TOOLS



**CASE WITH WHEELS
FOR EASY TRANSPORT**

Kist met wielen voor makkelijk transport
Boîte à roulettes pour un transport facile
Box mit Rädern für einfachen Transport
Caja con ruedas para facilitar el transporte

**FITS
HEX
CONNECTION**

**VIBRATION REDUCTION
SYSTEM**

+ FLAT CHISEL

+ POINTED CHISEL

POWX11861

DEMOLITION HAMMER 1700W

BREKHAMER
MARTEAU PIQUEUR
ABBRUCHHAMMER
MARTILLO DEMOLICIÓN



IMPORTANT FEATURES

**1700
WATT**

**1900
strks/min**

**60J
IMPACT
FORCE**

**3
YEAR
WARRANTY**



- 1 LOCKING BOLT + TOOL CHUCK**
VERGRENDELBOUW + GEREEDSCHAPSHOUDER
BOULON DE VERROUILLAGE + MANDRIN PORTE-OUTIL
VERRIEGELUNGSBOLZEN + AUFNAHME FÜR EINSÄTZE
PERNO DE BLOQUEO + MANDRIL DE HERRAMIENT
- 2 AUXILIARY HANDLE LOCK KNOB**
VERGRENDELKNOP VAN DE HULPHANDGREEP
BOUTON DE BLOCAGE DE LA POIGNÉE SUPPLÉMENTAIRE
VERSCHLUSS FÜR ZUSATZGRIFF
BLOQUEO DEL ASA AUXILIAR
- 3 VIBRATION REDUCTION SYSTEM**
TRILLINGSREDUCTIE
SYSTÈME DE RÉDUCTION DES VIBRATIONS
VIBRATIONSREDUKTIONSSYSTEM
REDUCCIÓN DE LA VIBRACIÓN
- 4 INSPECTION WINDOW / OIL FILLER OPENING**
INSPECTIEVENSTER / OLIEVULOPENING
FENÊTRE D'INSPECTION / ORIFICE DE REMPLISSAGE D'HUILE
SICHTFENSTER / ÖFFNUNG ZUM ÖL AUFFÜLLEN
VENTANA DE INSPECCIÓN / APRETURA DE LLENADO DE ACEITE

geen foto met onderkant

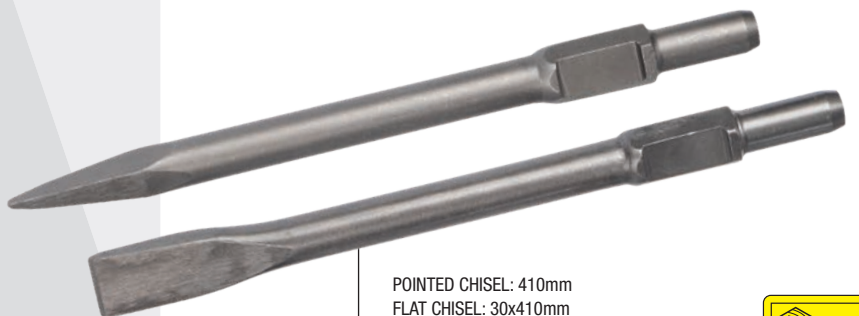

POINTED CHISEL: 410mm
FLAT CHISEL: 30x410mm
(HEX CONNECTION)



POWERPLUS
HIGH QUALITY TOOLS



POWX11861

DEMOLITION HAMMER 1700W

You use this stunning performer from Powerplus to break through concrete, brick and stone. With a 1700W motor and an impact force of 60 joules, your demolition works will progress rapidly. In no time you will have space for the construction of new pipes and cables. Thanks to the Hex connection you easily fix the drill in a drill chuck.

This strong demolition hammer obtains 1.900 strokes per minute. Thanks to the excellent anti-vibration system, you nearly feel any vibration and are able to work very comfortably. So using the POWX11861 is pleasant, even when you continue for a while. Its soft grip makes the device fit perfectly in your hand and the second handle provides even more comfort.

The Powerplus demolition hammer is supplied in a carrying case with wheels, so you can easily store and transport the machine. You will find one pointed and a flat chisel in the case too.



TECHNICAL SPECIFICATIONS POWX11861		Features	Box content	Symbols
Rated voltage - frequency	230-240V~ 50Hz	<ul style="list-style-type: none"> • 1 function: - chiseling • HEX-connection • Auxiliary handle • Vibration reduction system • Soft grip 	1x demolition hammer	
Rated power	1700W		1x auxiliary handle	
Impact force	60J		1x pointed chisel: 410mm	
Max. impact rate	1900 strokes per minute		1x flat chisel: 30x410mm	
Cable	5m		1x grease tube	
			1x wrench	
			1x manual	
			1x BMC with wheels	

KREATOR

THE RIGHT SAFETY ACCESSORIES FOR EVERY JOB

HEARING PROTECTION	SAFETY GLASSES	GLOVES

VARO

VARO - VIC.VAN ROMPUY nv - DIY & GARDEN TOOLS
JOSEPH VAN INSTRAAAT 9 - 2500 LIER - BELGIUM
TEL +32 (0)3 292.92.92 | FAX +32 (0)3 292.92.72
INFO@VARO.COM | WWW.VARO.COM

Box (piece)



Our +50 years of experience guarantee a professional and high quality service.