

SET COMPACT

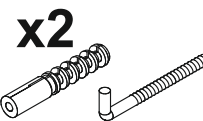
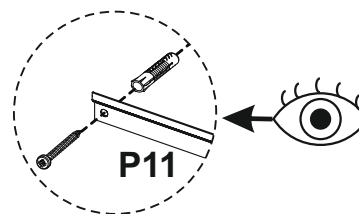
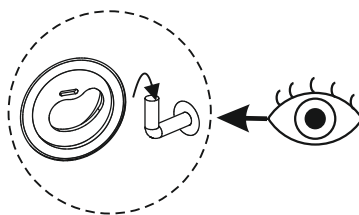
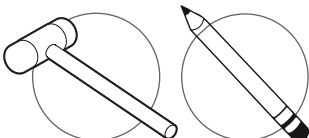
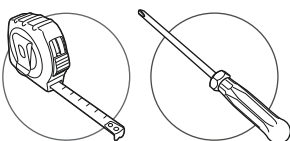
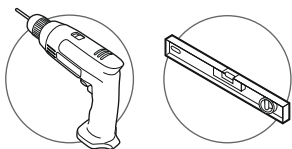
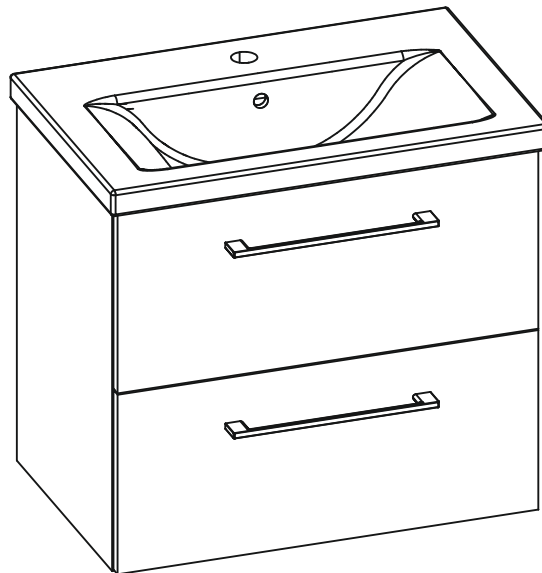
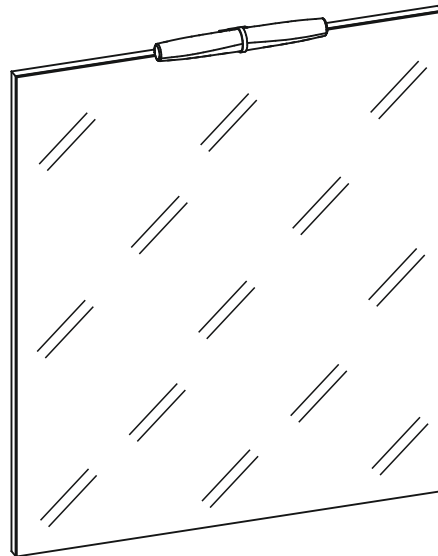

Wybierz / Kup materiał montażowy odpowiedni do rodzaju ściany.

Befestigungsmaterial entsprechend der Wandbeschaffenheit wählen/kaufen.

Choose/Buy mounting material according to the wall texture.

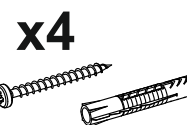





Podczas wiercenia należy stosować odpowiedni sprzęt ochronny (okulary ochronne, ochrona słuchu).

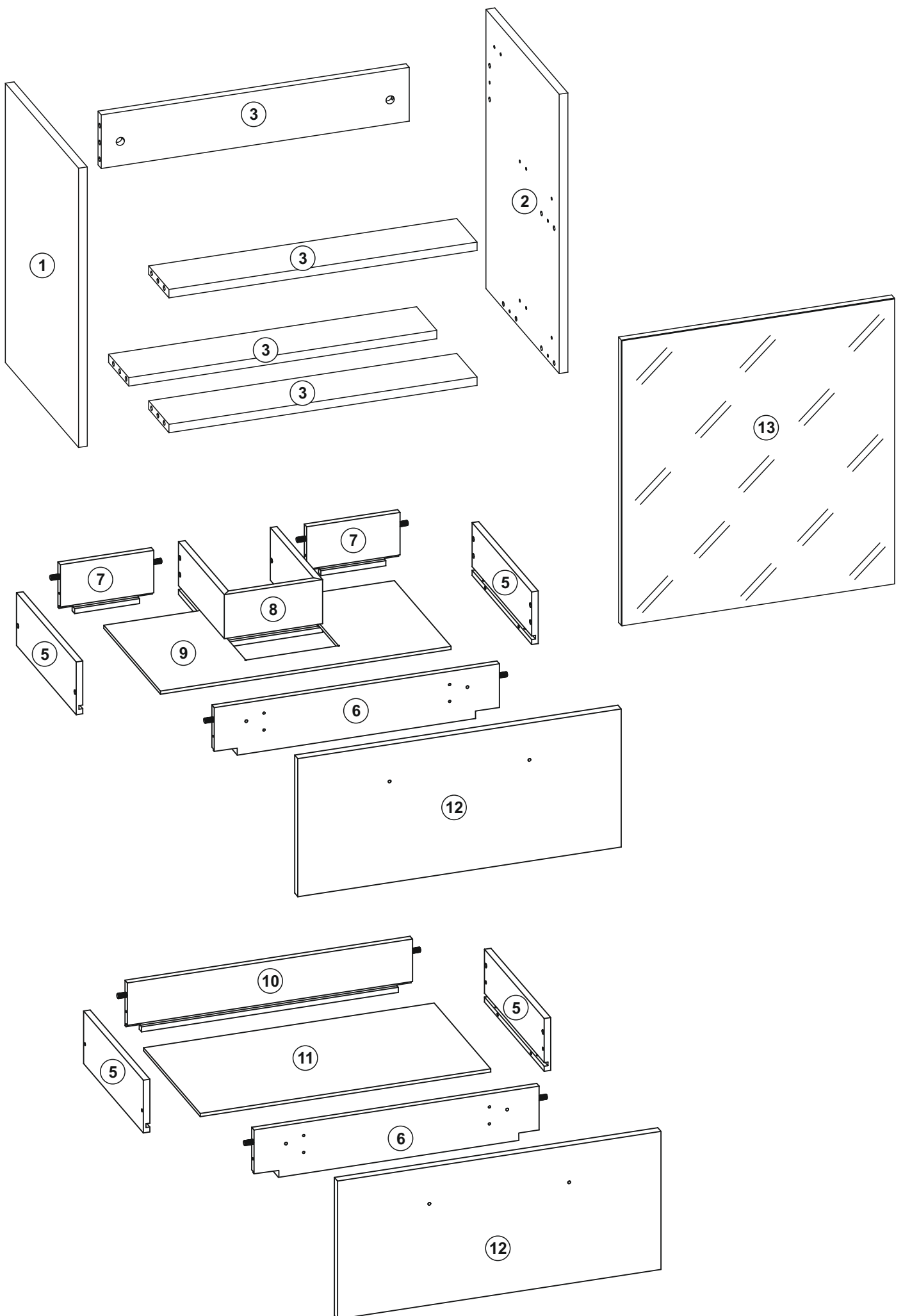

Beim Bohren entsprechende Schutzausrüstung (Schutzbrille, Gehörschutz) tragen.

Wear appropriate protective equipment when drilling (safety goggles, ear protection).

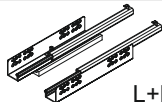



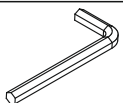



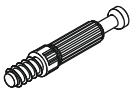

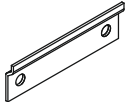
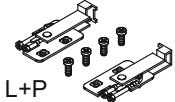

C4	PHQ30	I4
 Euro 6,3x13	 L+P	 UP3x20
x 12	x 2	x 4

M3	G2
	 5 x 40
x 1	x 10

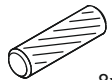
E1	F1
	
x 8	x 8

H	K1
	 M4x22
x 2	x 4

P11	ZR2
	 L+P
x 2	x 1

A1	D1	I10	R4	R8	R9
 8x30		 UP 4x23		 ø8	 11x5
x 16	x 4	x 8	x 4	x 4	x 4

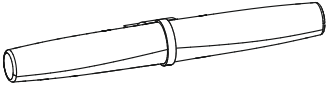
LED	
<p>Zródło światła niniejszej oprawy oświetleniowej jest niewymienne. Die Lichtquelle dieser Leuchte kann nicht ersetzt werden. The light source of this luminaire is not replaceable.</p>	
 UP 3,5x16 x2	
<p>Dieses Produkt enthält eine Lichtquelle der Energieeffizienzklasse F</p>	
x 1	



Urządzenia elektroniczne są odpadami nadającymi się do recyklingu i nie mogą być wyrzucane razem z odpadami domowymi. Na zakończenie użytkowania, produkt należy zutylizować zgodnie z obowiązującymi wytycznymi regulacyjnymi.

Elektronische Geräte sind Wertstoffe und gehören nicht in den Hausmüll. Entsorgen Sie das Produkt am Ende seiner Lebensdauer gemäß den geltenden gesetzlichen Bestimmungen.

Electronic devices are recyclable waste and must not be disposed of in the household waste. At the end of its service life, dispose of the product in accordance with applicable regulatory guideline.

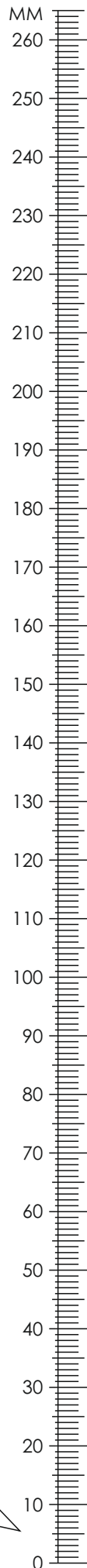
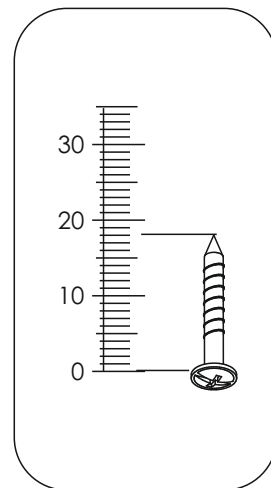

1

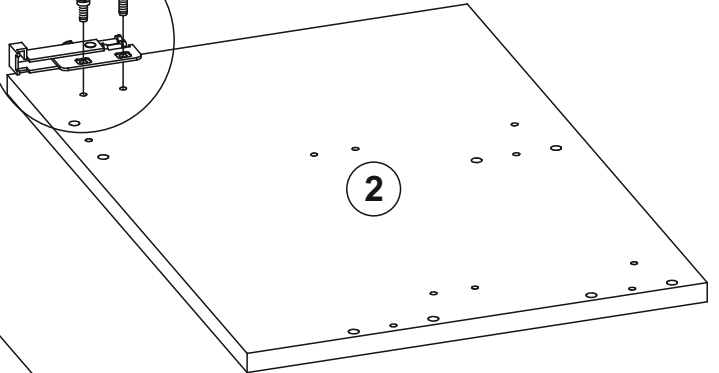
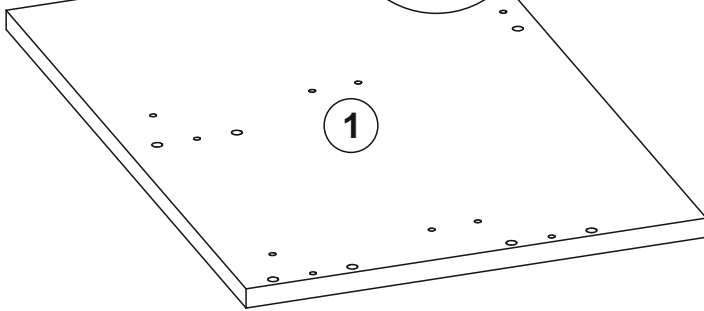
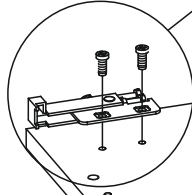
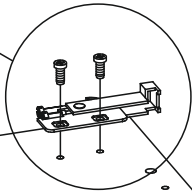
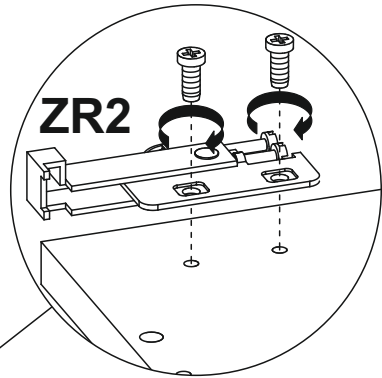
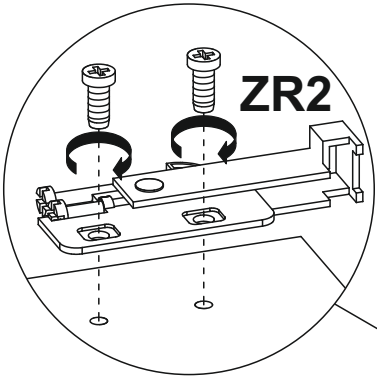
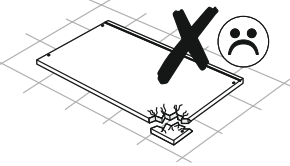
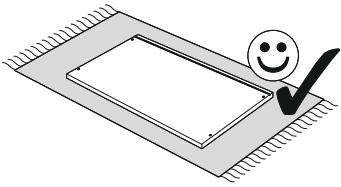

2

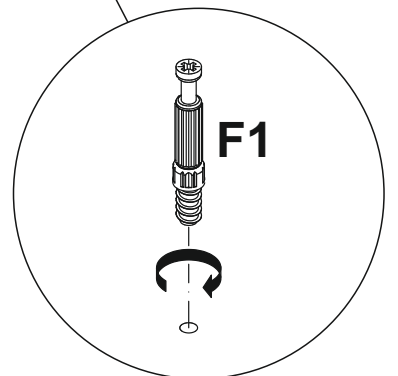
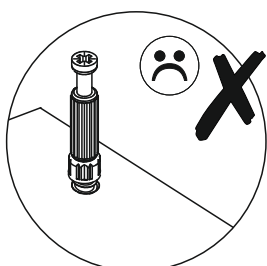
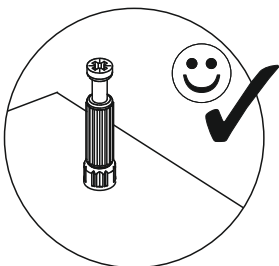
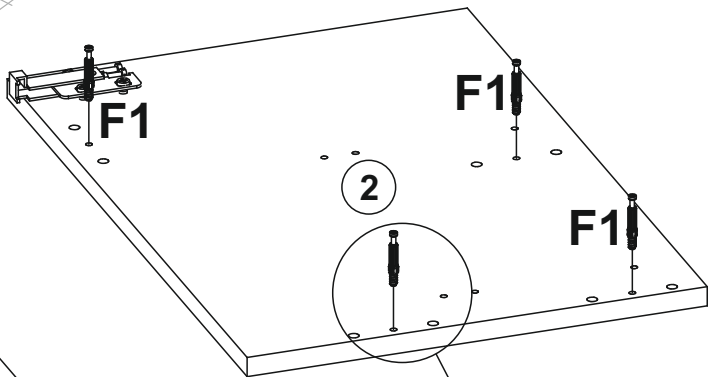
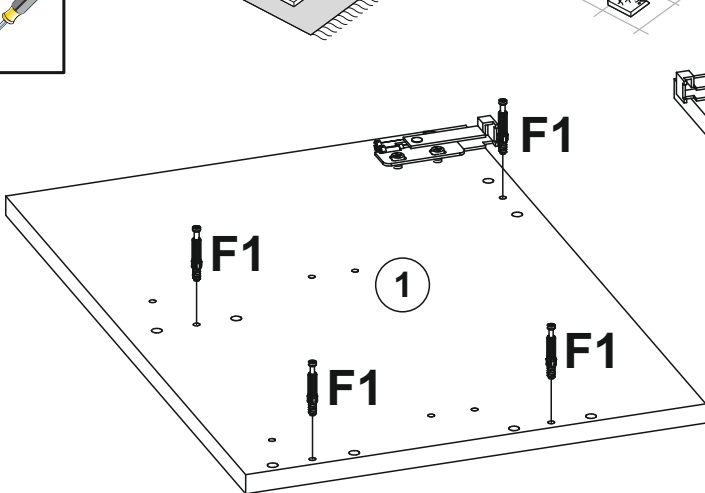
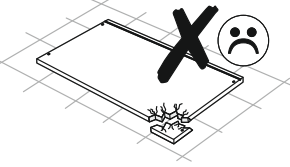
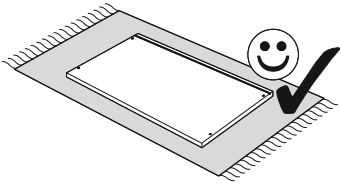

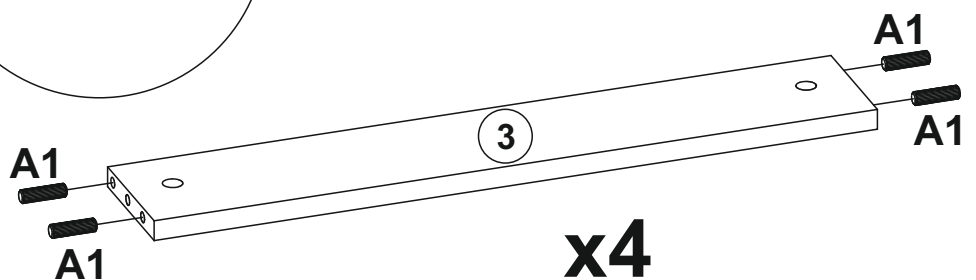
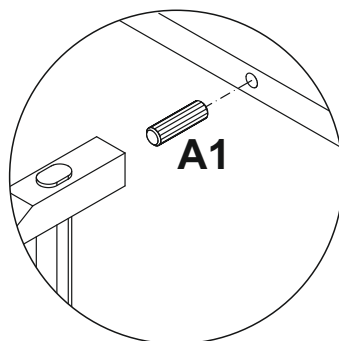
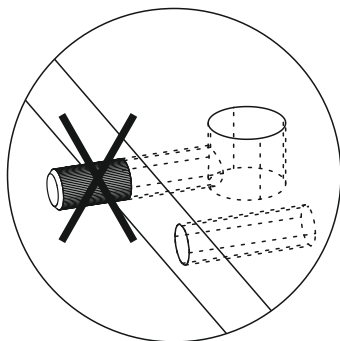
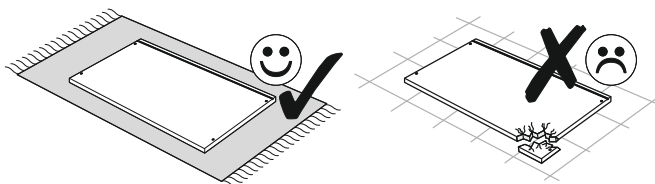
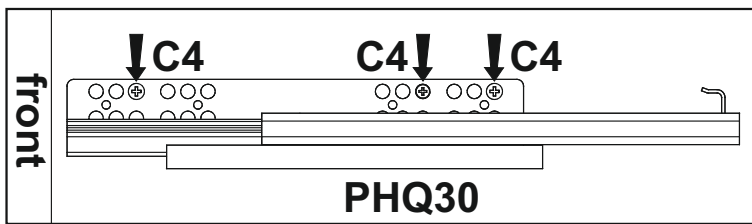
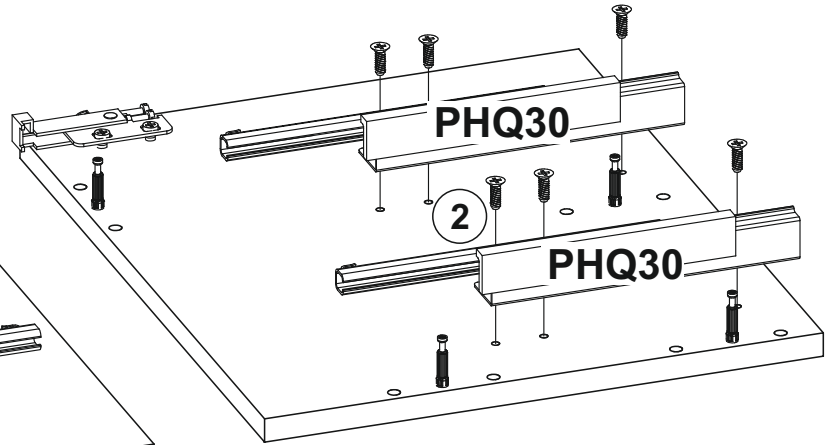
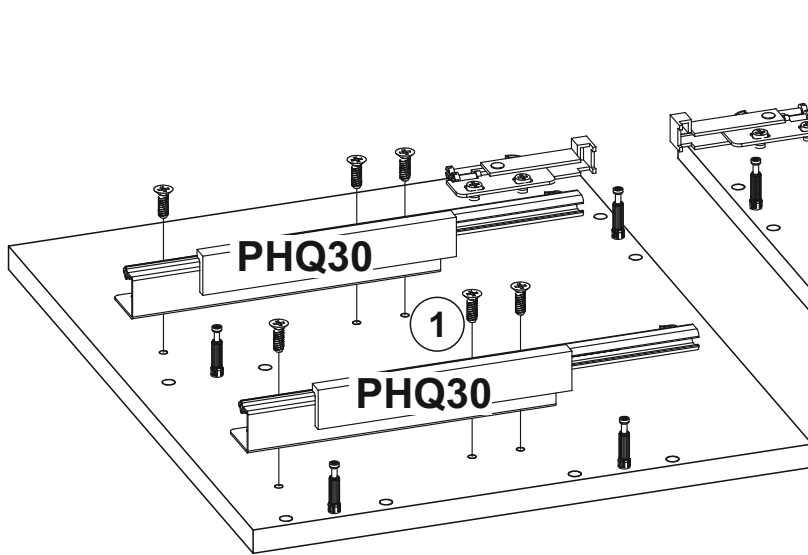
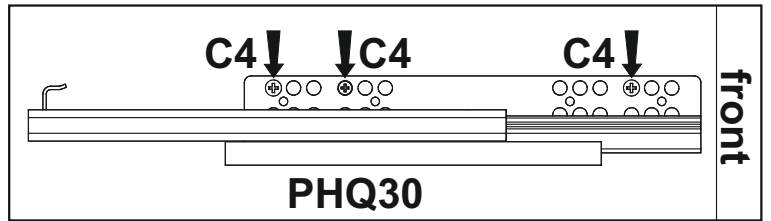
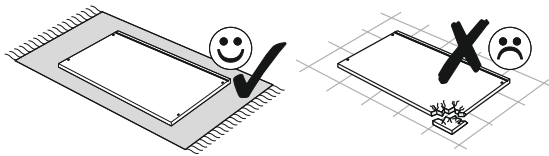

5

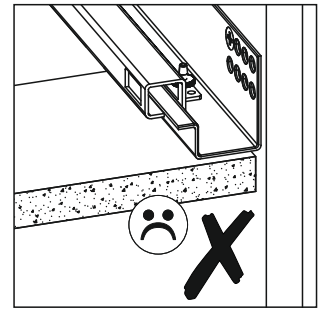
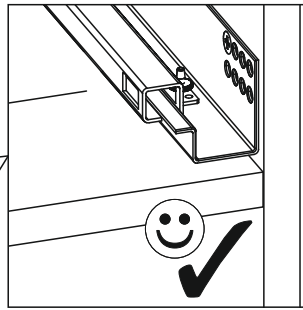
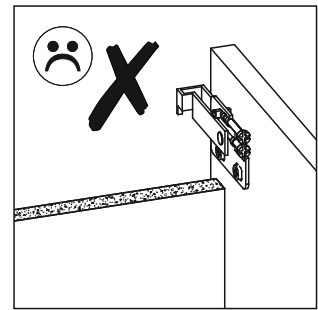
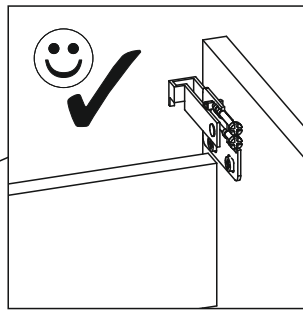
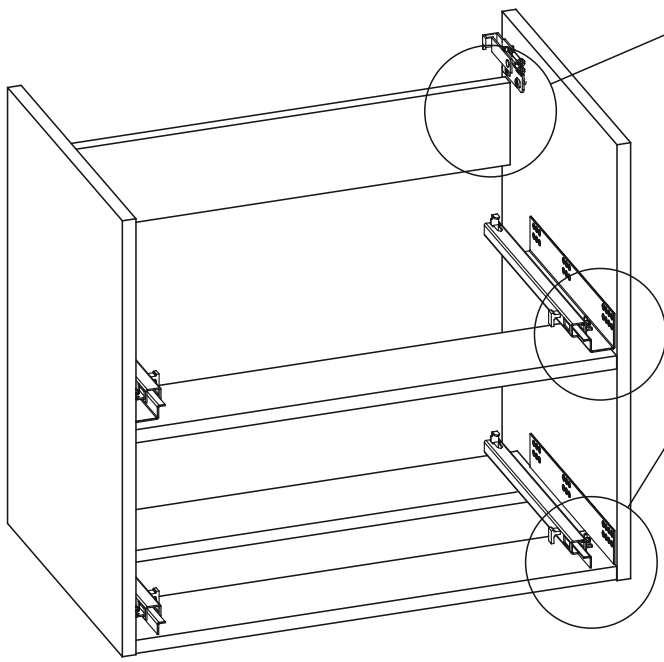

6

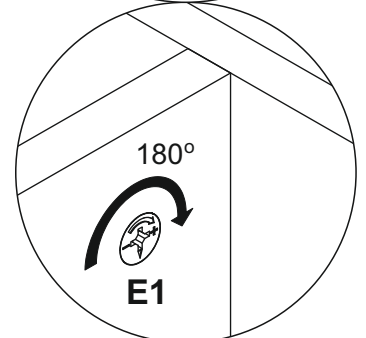
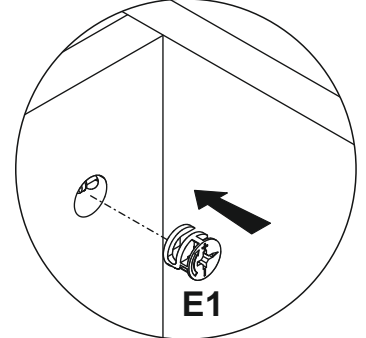
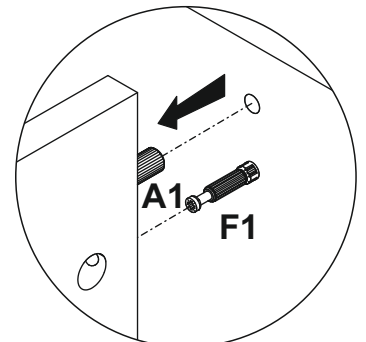
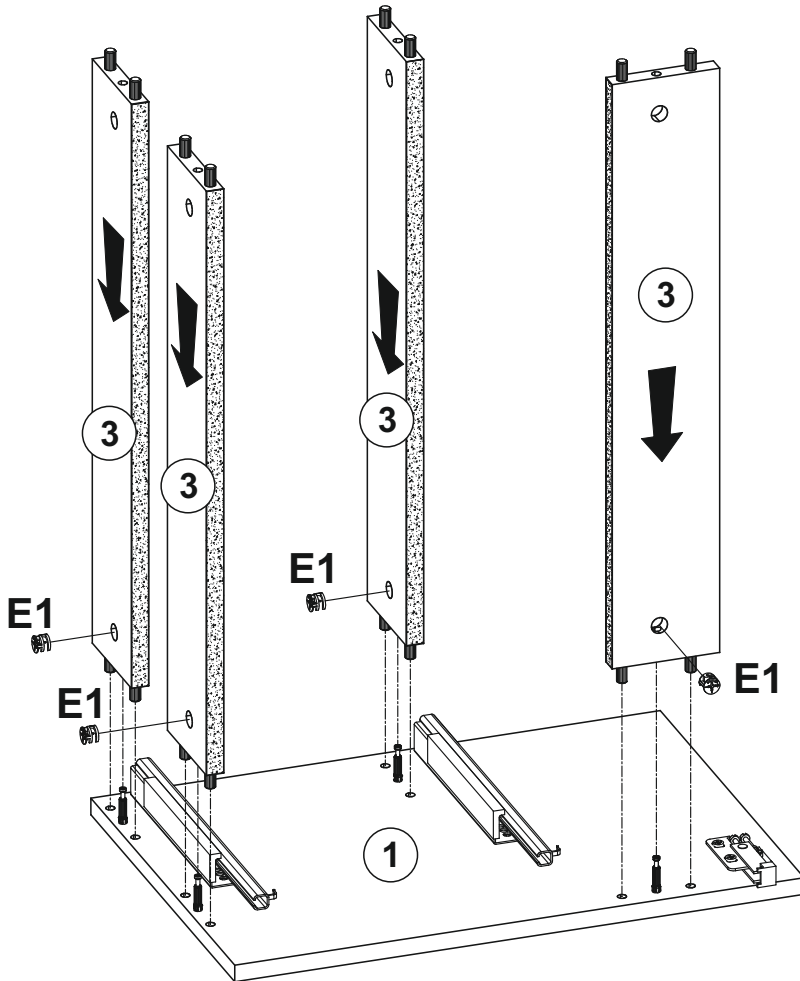
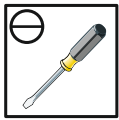

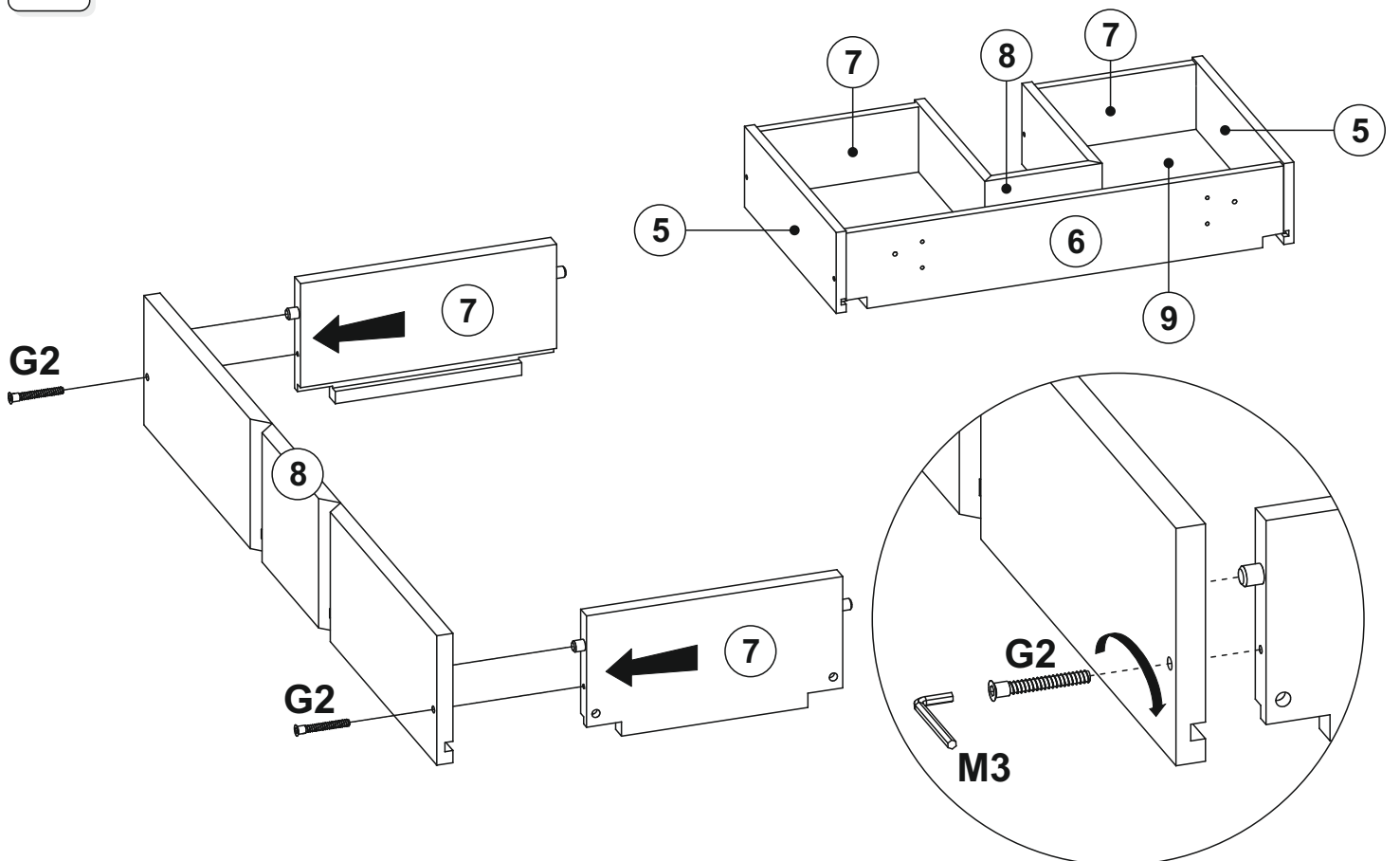
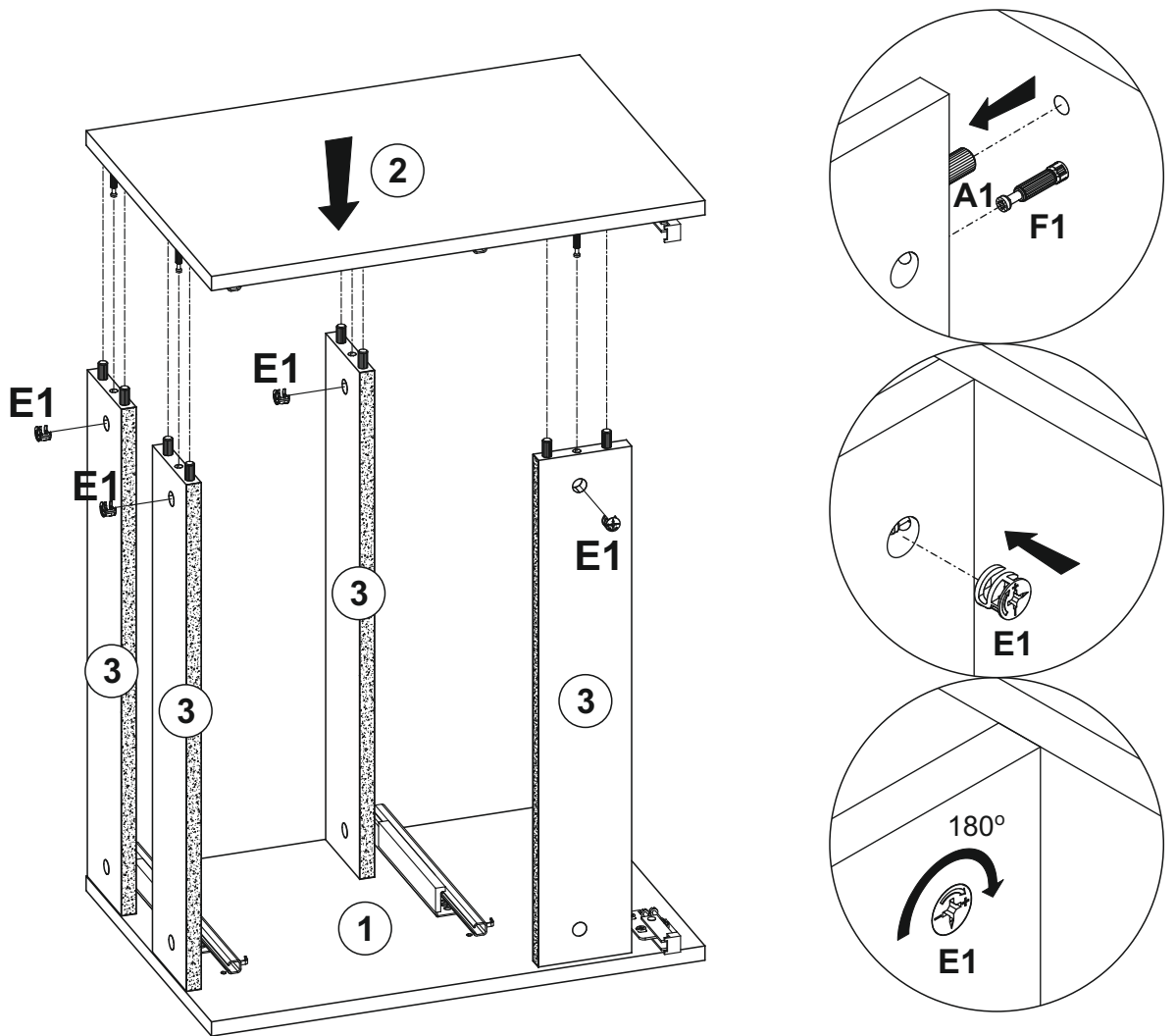
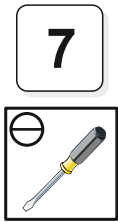

9

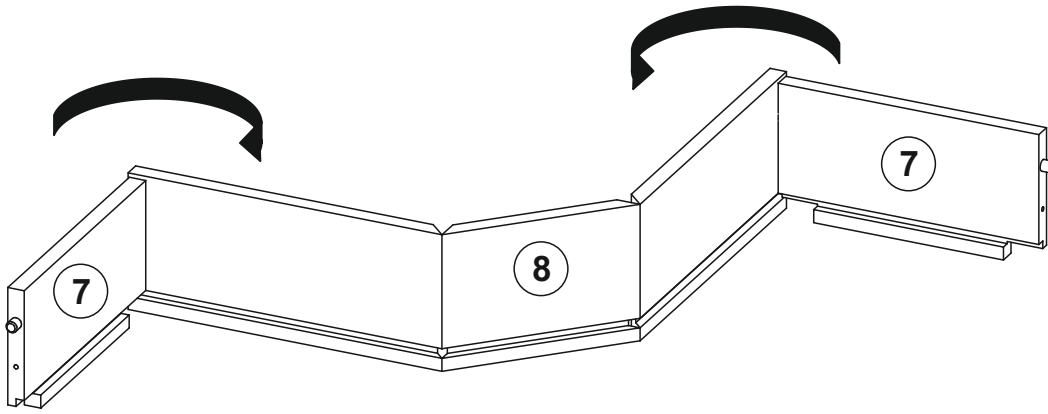

10

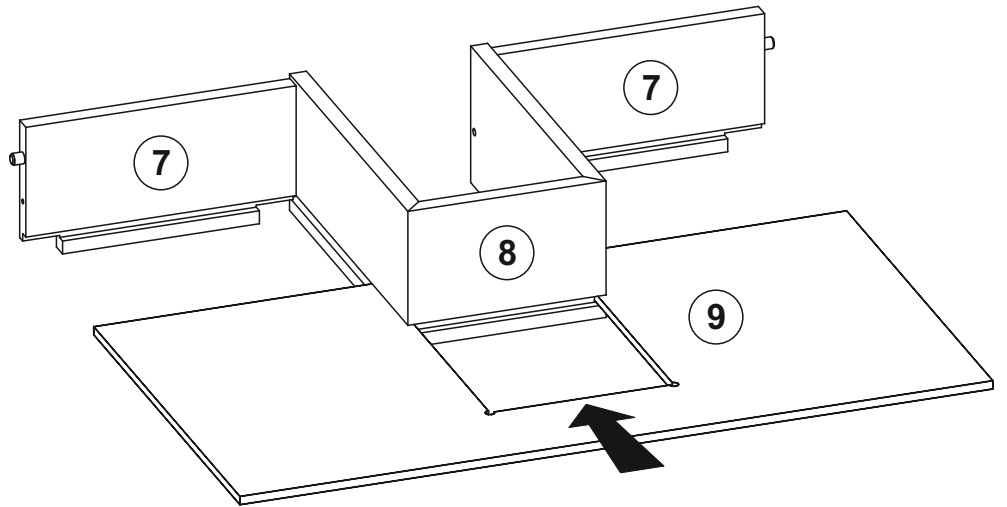

11

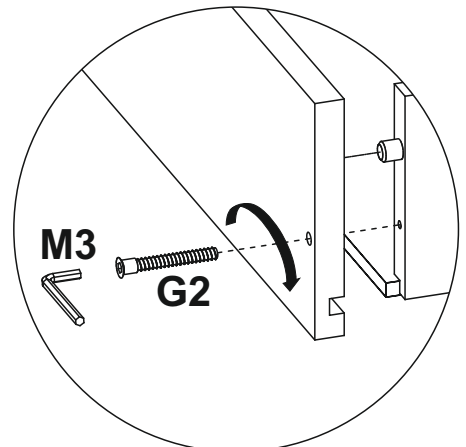
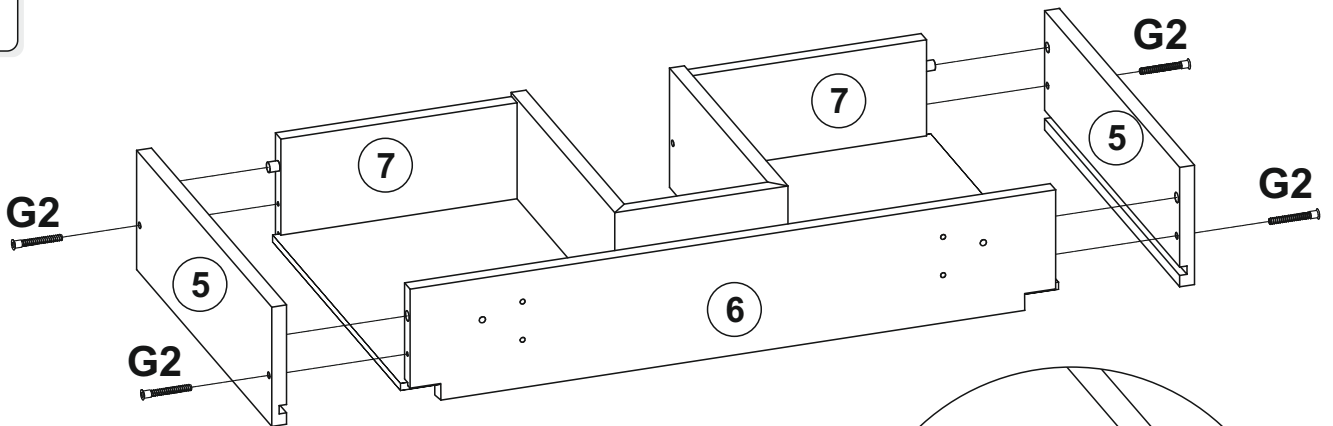

12

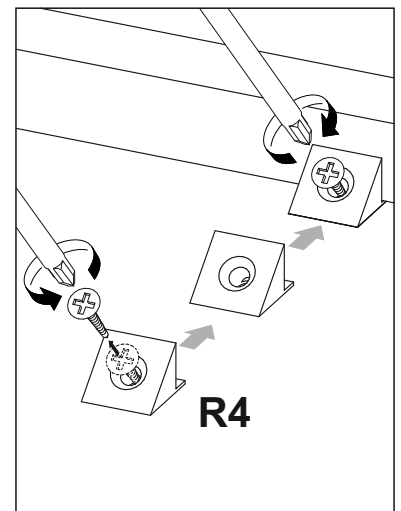
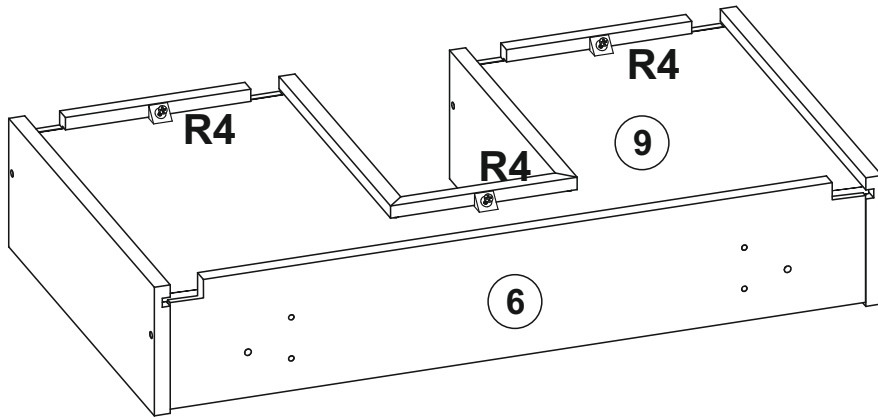
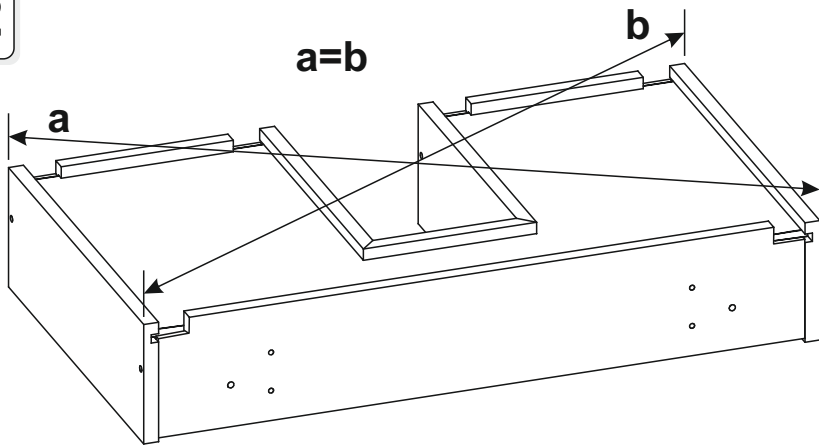

13

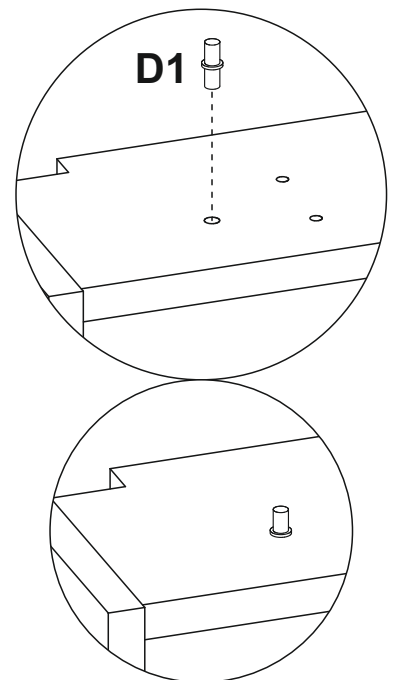
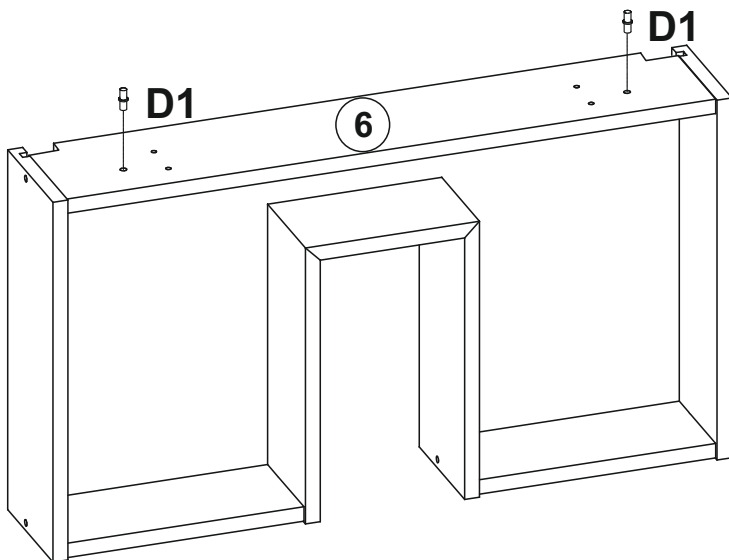

14

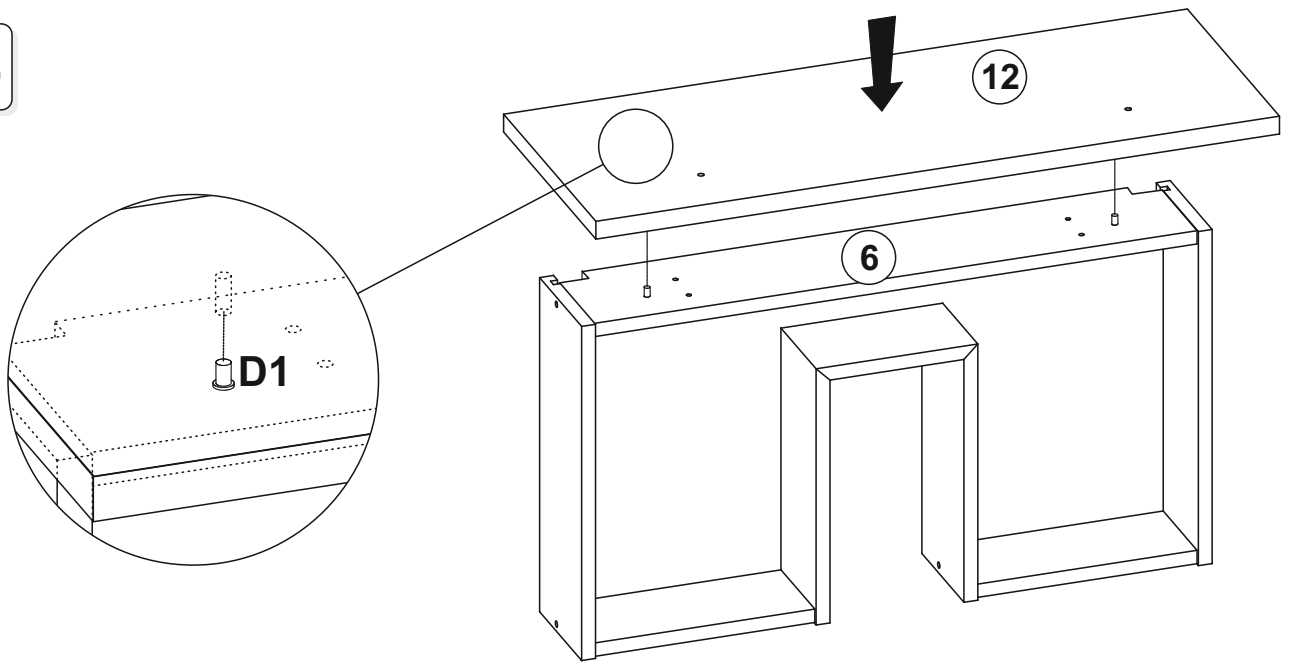

15

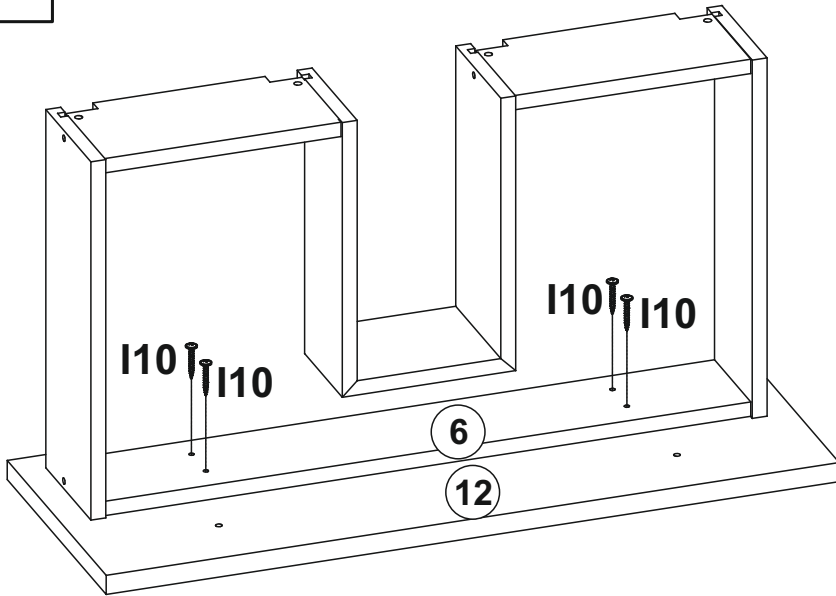
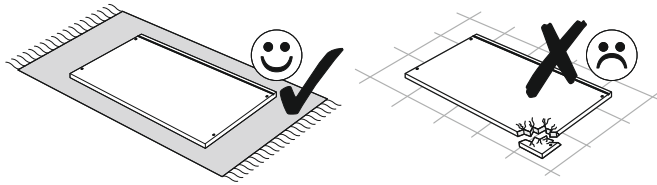

16

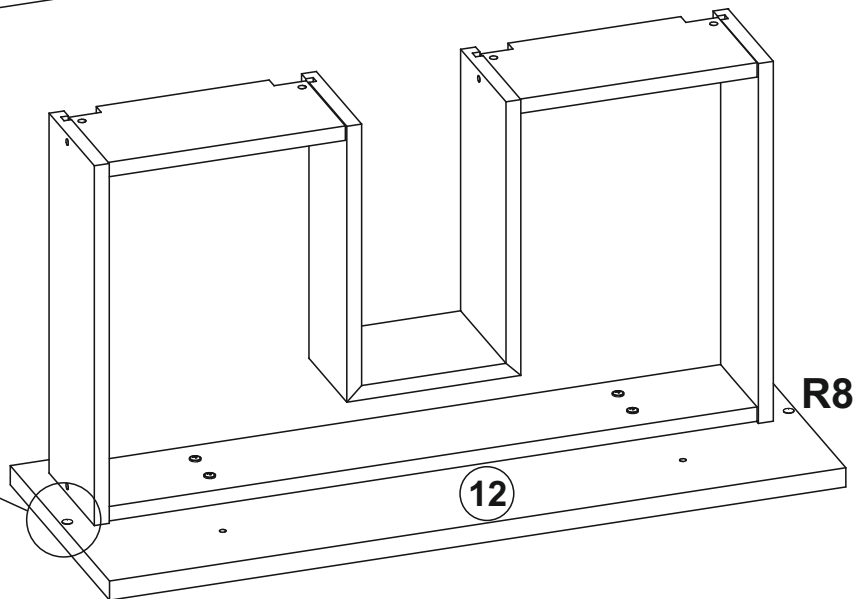
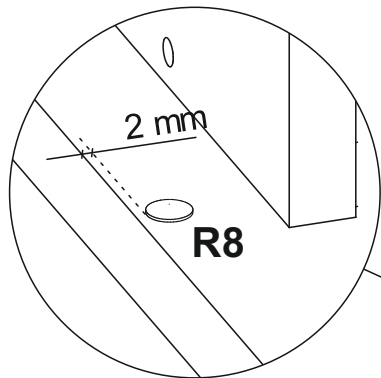

17

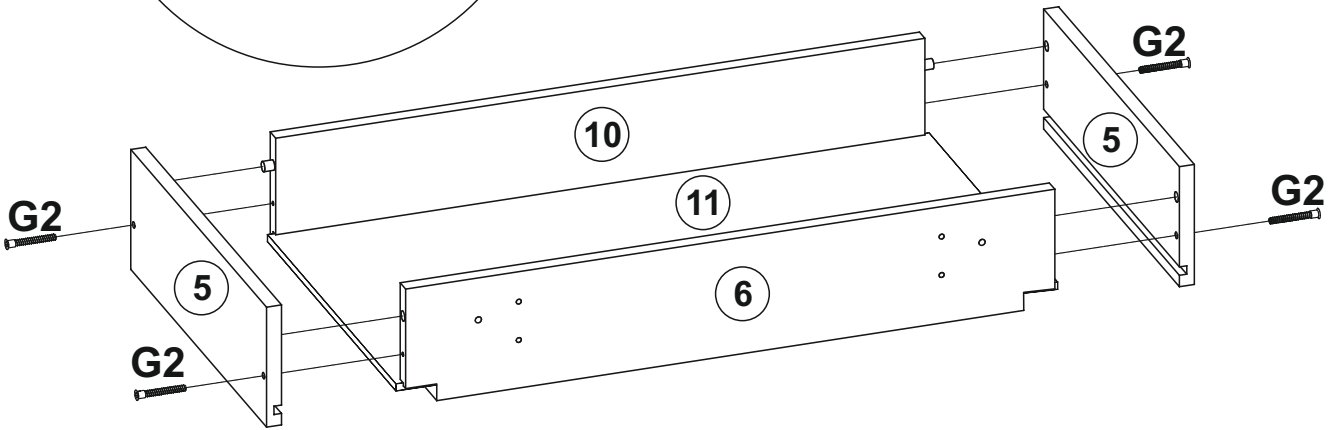
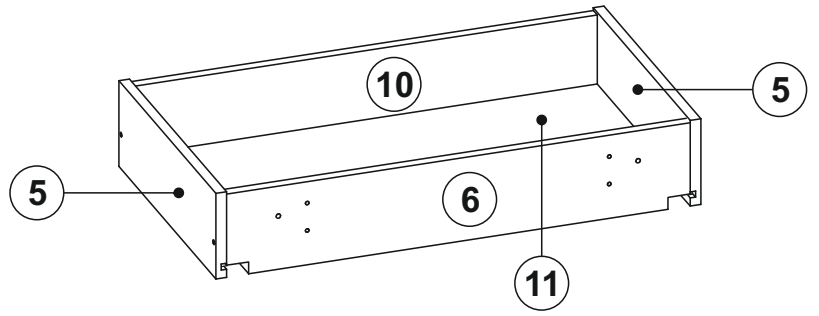
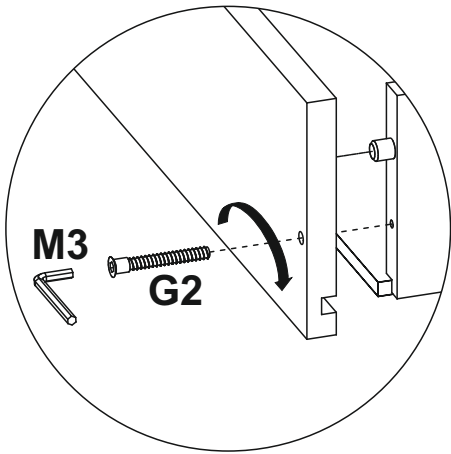

18

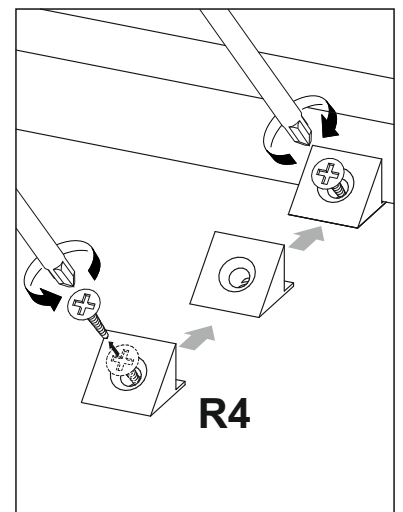
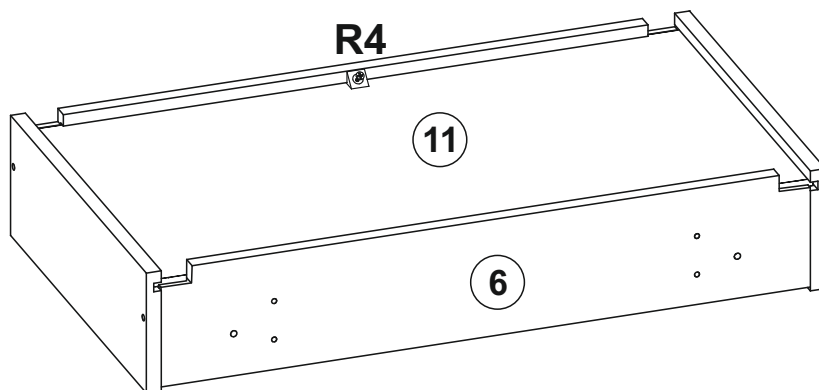
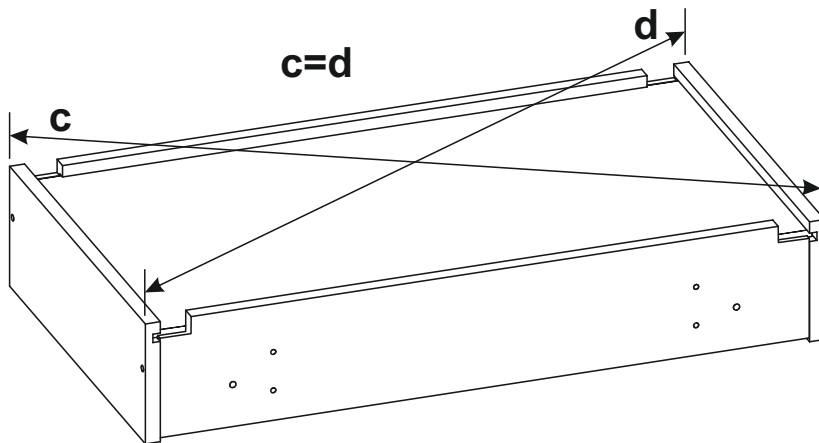

19

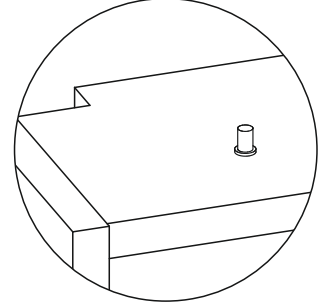
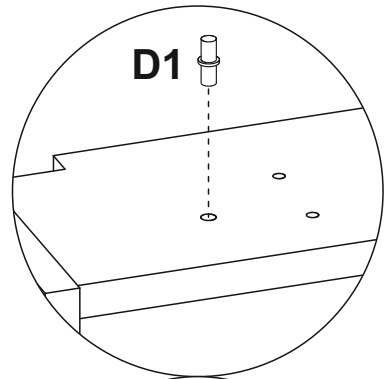
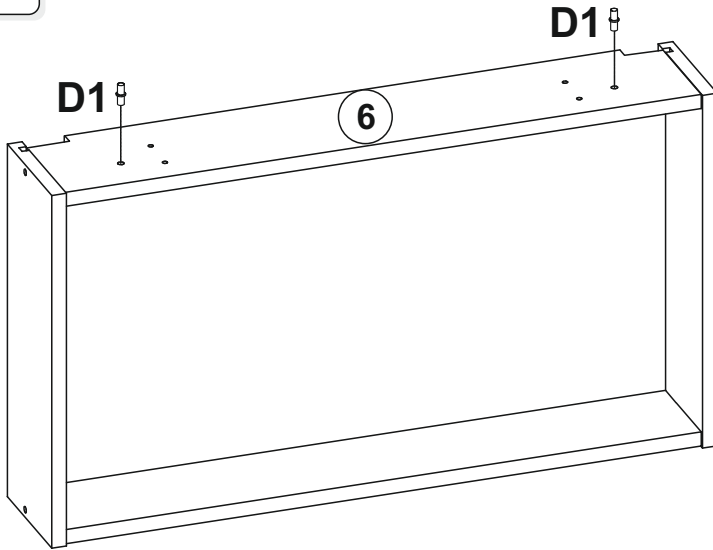

20

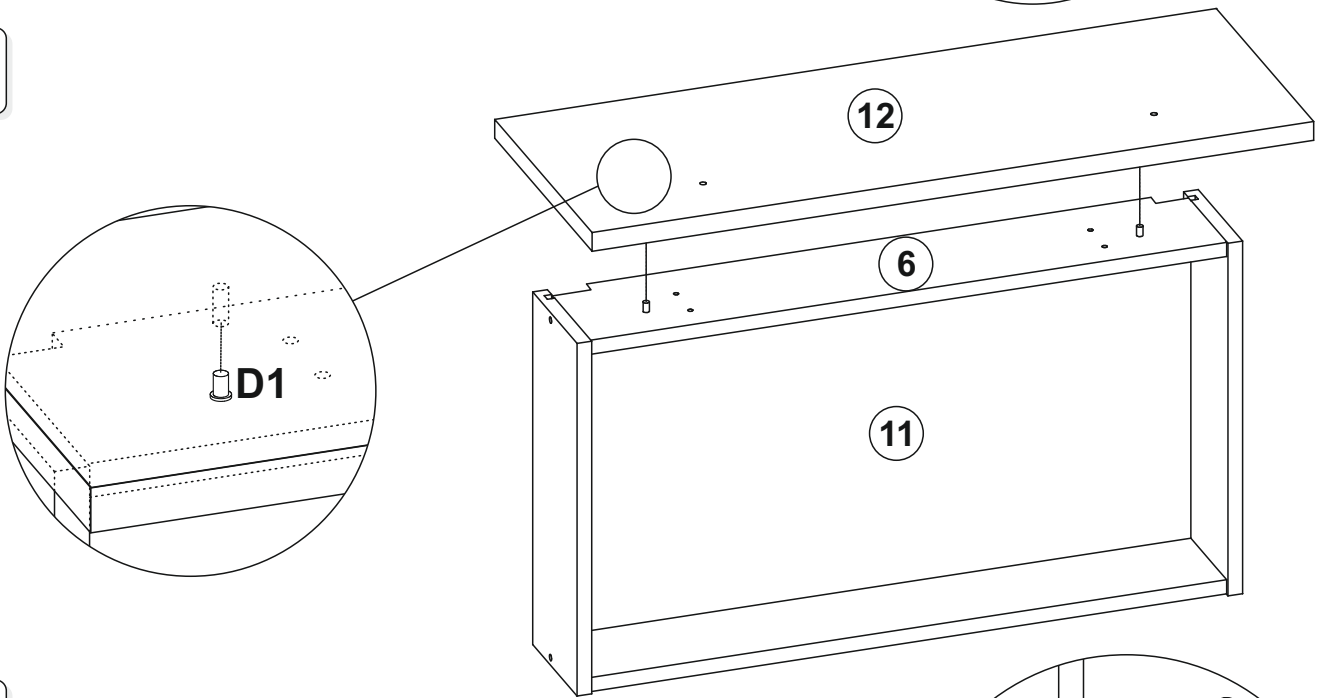

21

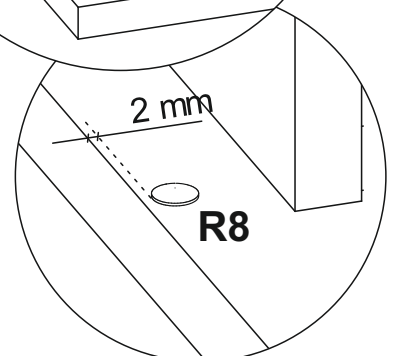
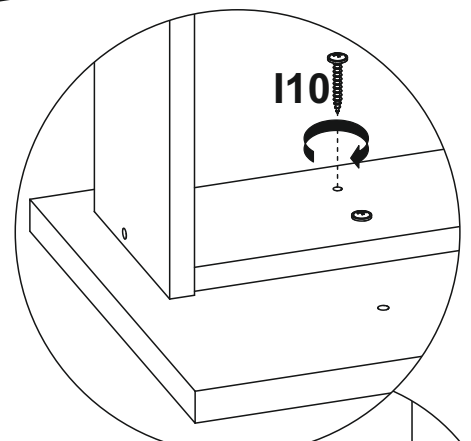
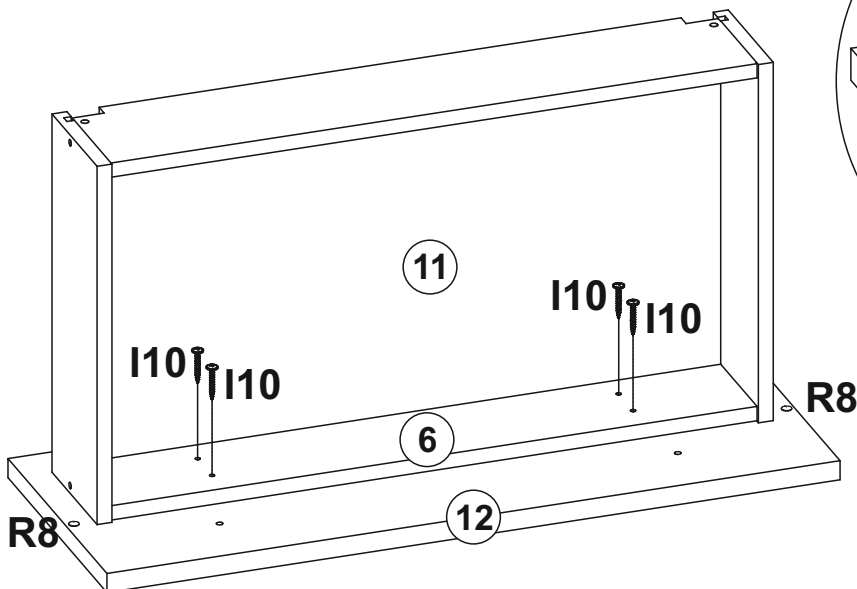

22

SET „60" - 56,4 cm
SET „80" - 76,4 cm

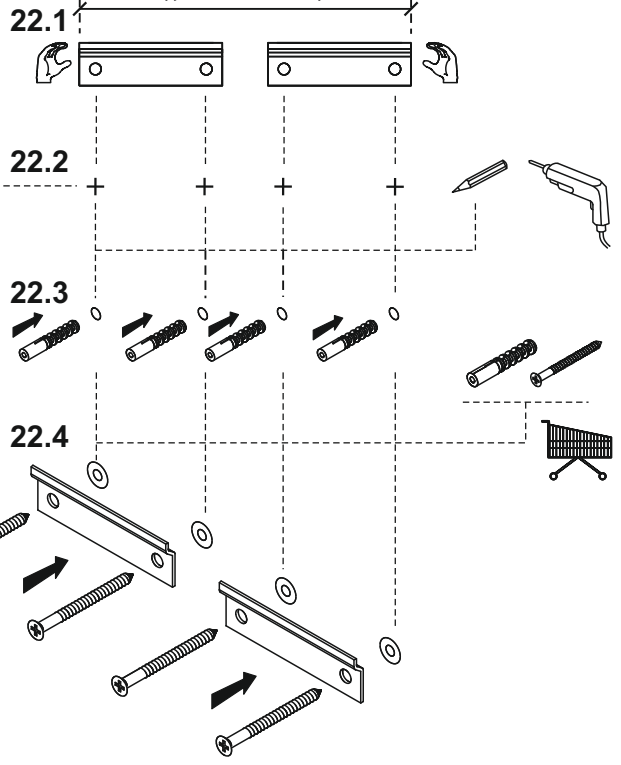
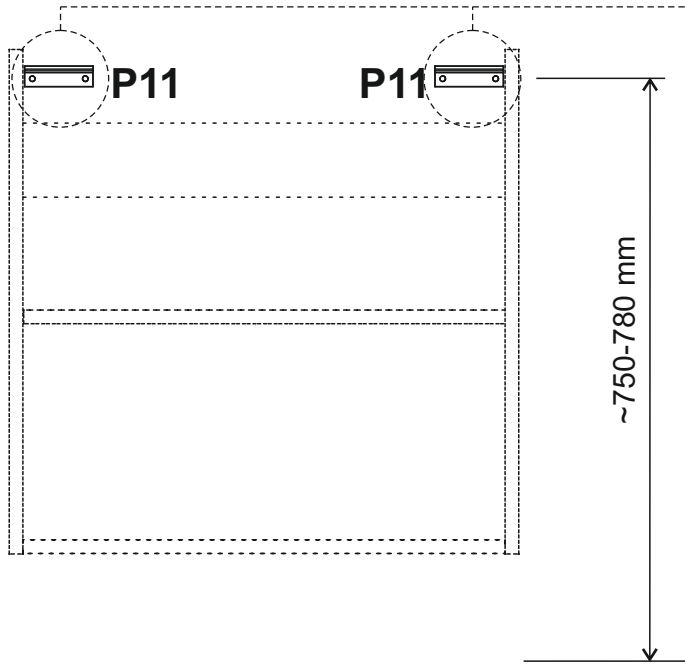

23

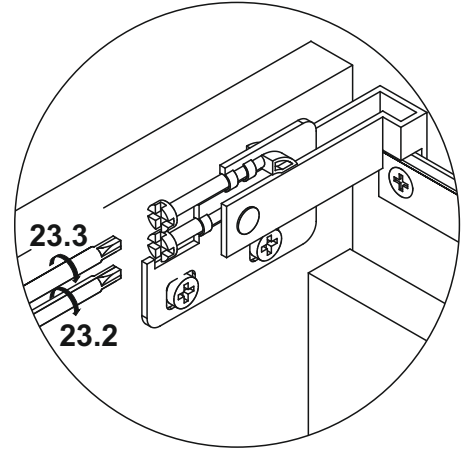
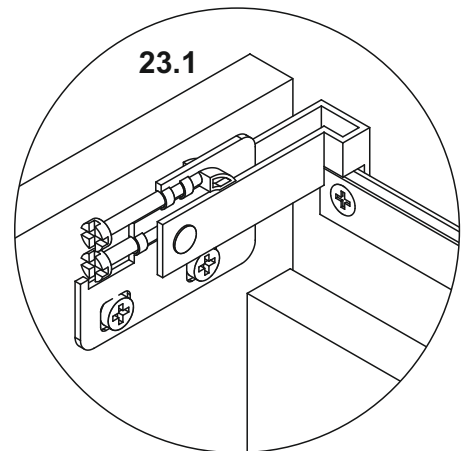
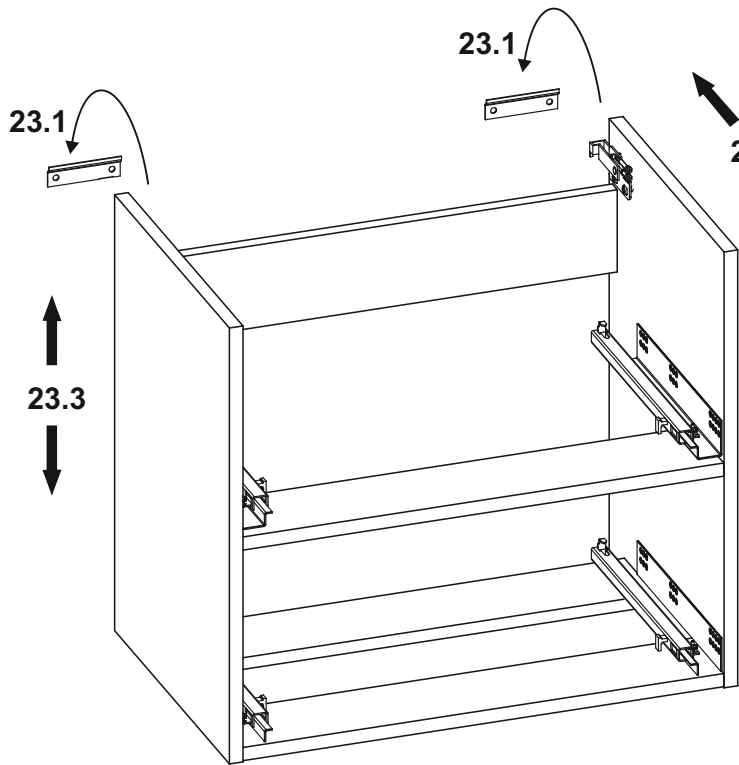

24

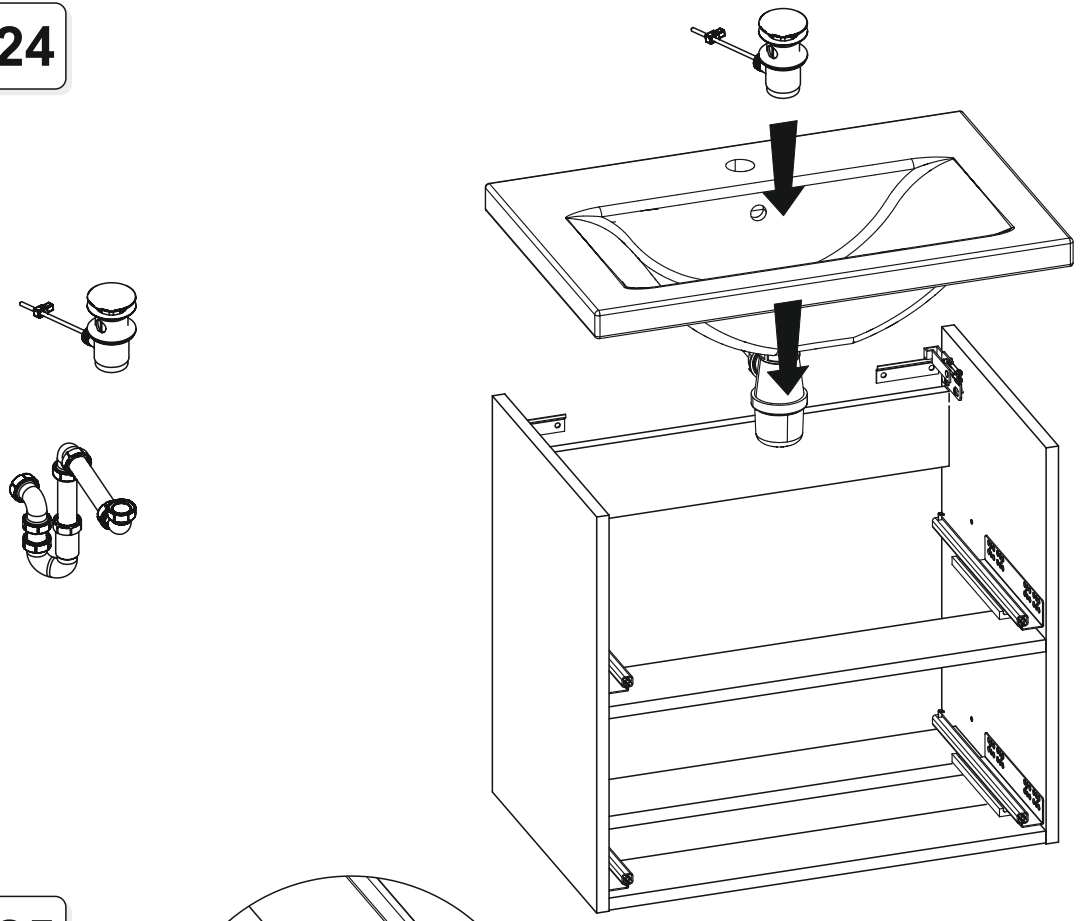

25

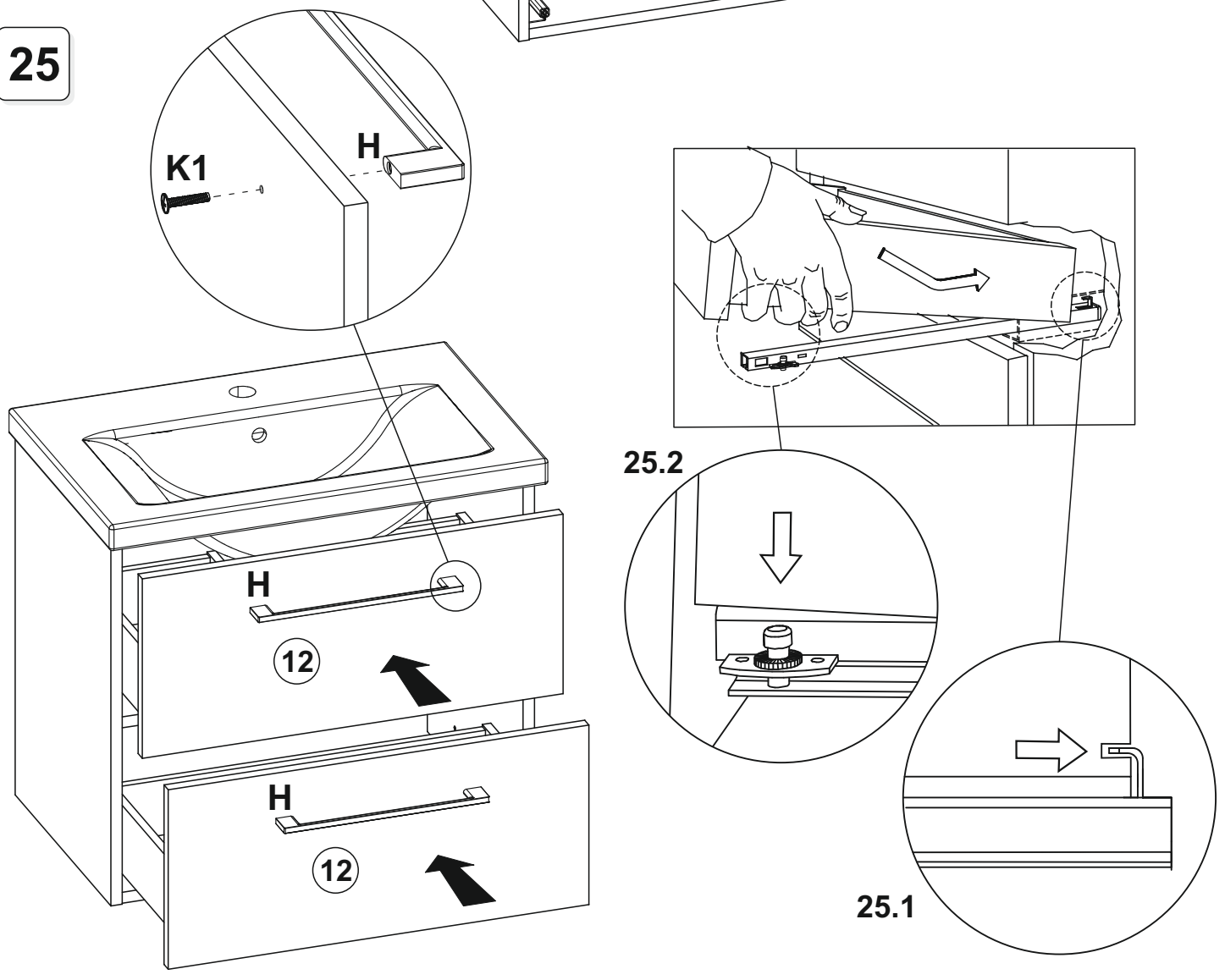

26

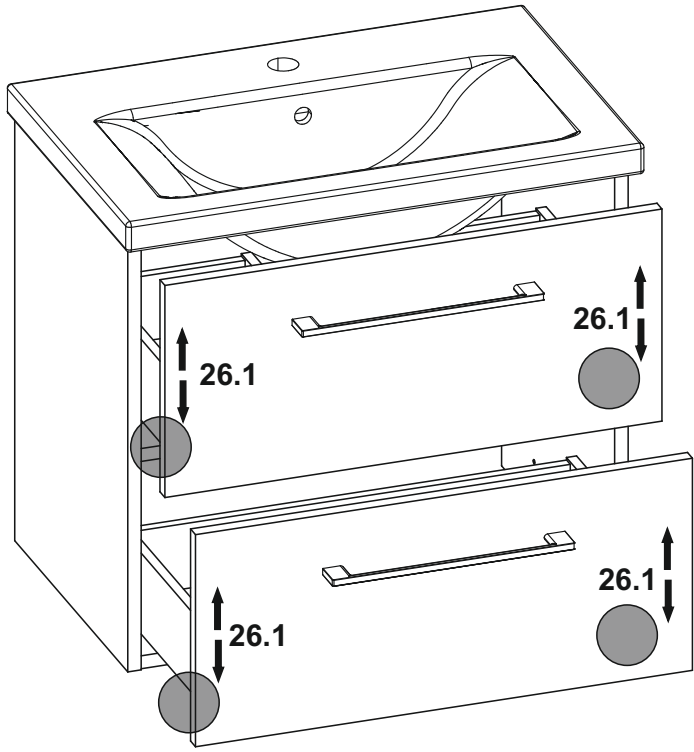

26.1

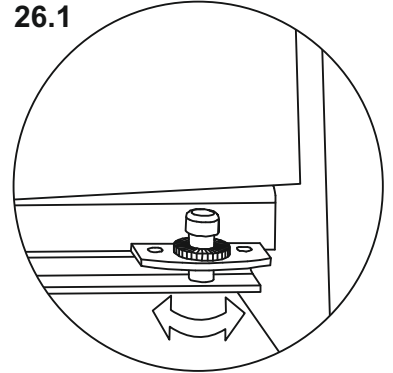

27

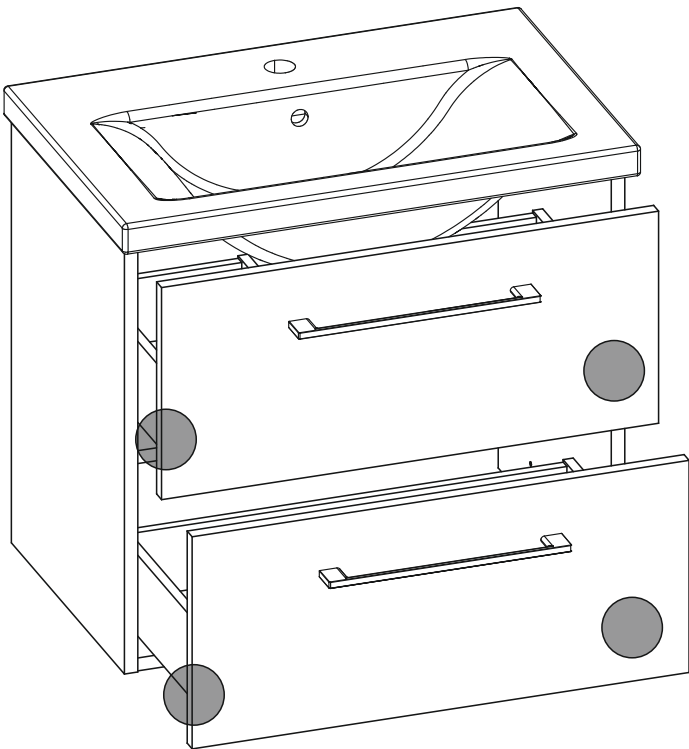

27.1

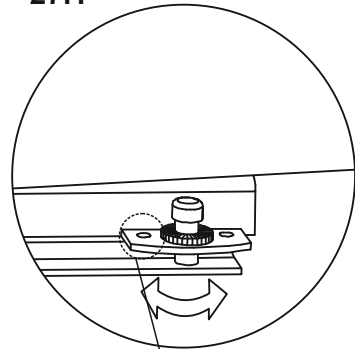

27.2

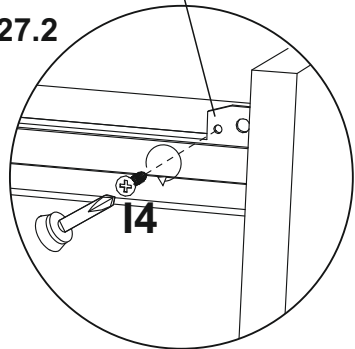

28

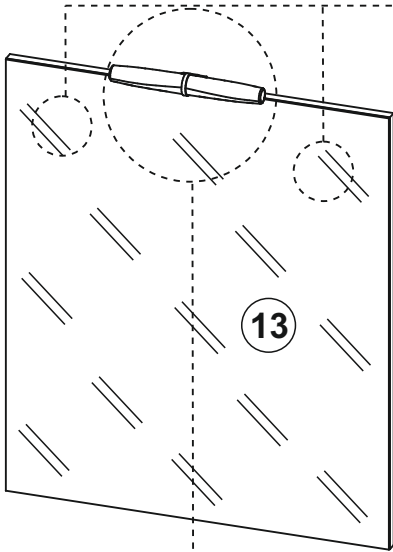

H=150-170 cm

28.1

SET „60” - 40 cm
SET „80” - 60 cm

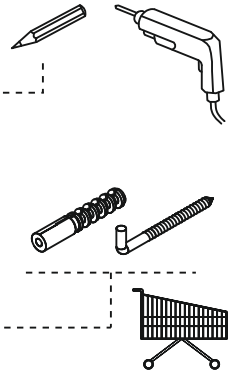
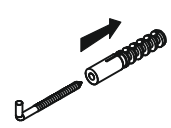
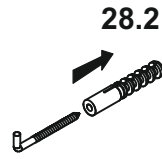

28.3

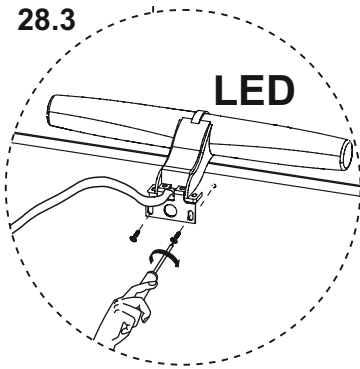

LED

28.2

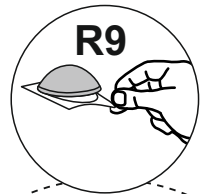
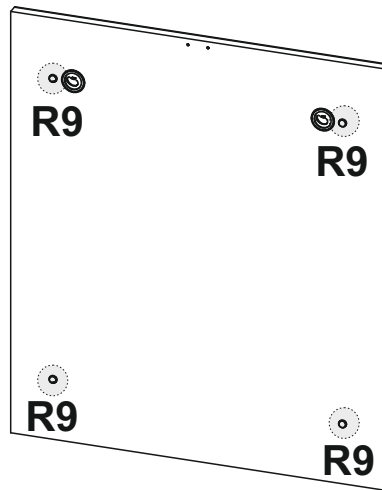

R9

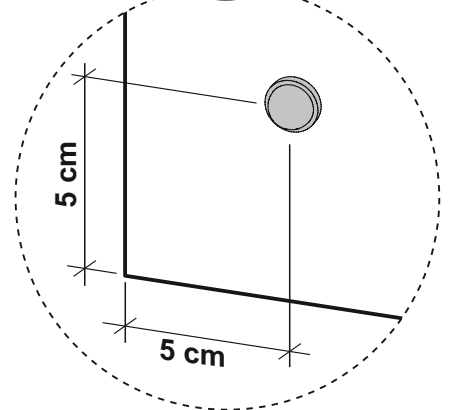

Zawsze odłącz zasilanie obwodu przed rozpoczęciem prac instalacyjnych. Instalację należy przeprowadzić przez autoryzowanego wykonawcę elektrycznego.

Vor der Installation der Beleuchtung den Strom abschalten. Die Installation sollte von einem qualifizierten Elektriker durchgeführt werden.

Always shut off power to the circuit before starting installation work.

The installation shall be carried out by an authorized electrical contractor.

28.4

