

In-Out 2,66×0,98m

47244S000 - B-000070

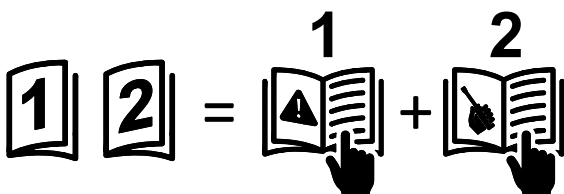

[EN] **Assembly notice - keep for later reference.**  
 [FR] **Notice de montage à conserver pour consultations ultérieures.**  
 [NL] **Te bewaren gebruiksaanwijzingen voor latere raadplegingen.**  
 [DE] **Montageleitung nicht wegwerfen, bewahren Sie diese für später.**  
 [IT] **Manuale di montaggio da conservare per ulteriori consultazioni.**  
 [ES] **Debe conservar las instrucciones de montaje para consultas posteriores.**  
 [PT] **Instruções de montagem a guardar para consultas futuras.**

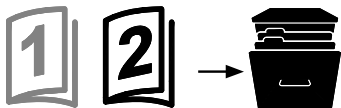
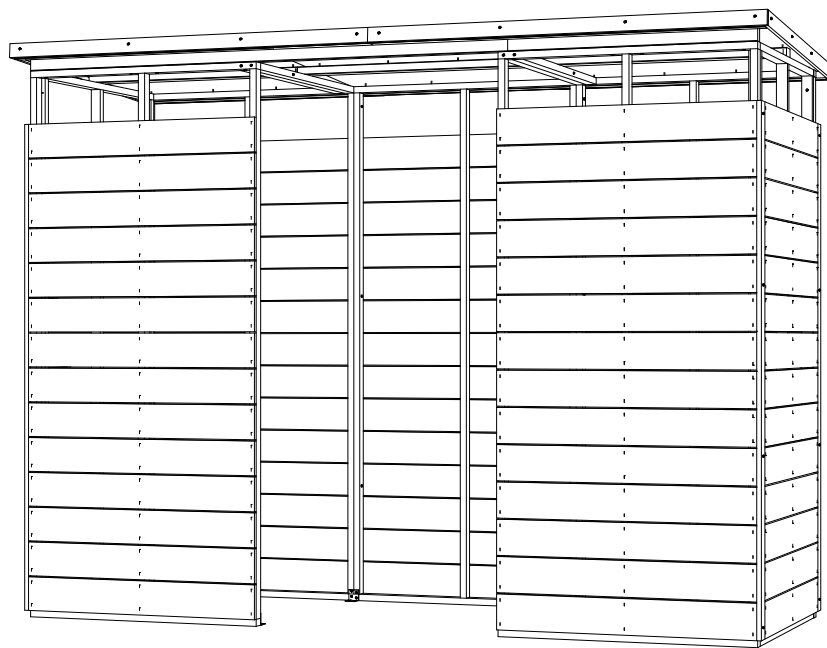
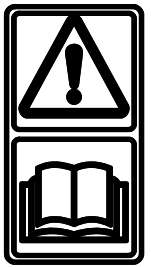

max. 50kg/m<sup>2</sup>

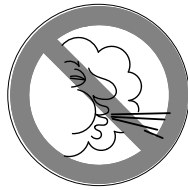

max. 100km/h

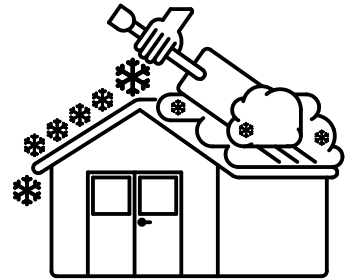

[EN] **Predrill**  
 [FR] **Préforer**  
 [NL] **Voorboren**  
 [DE] **Vorboren**  
 [IT] **Preforare**  
 [ES] **Preforar previamente**  
 [PT] **Perfuração**

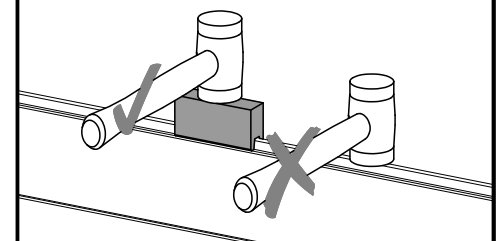
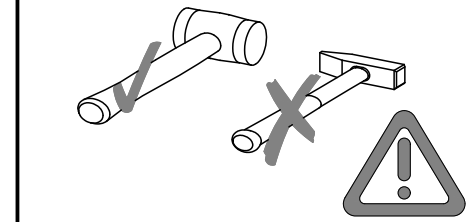
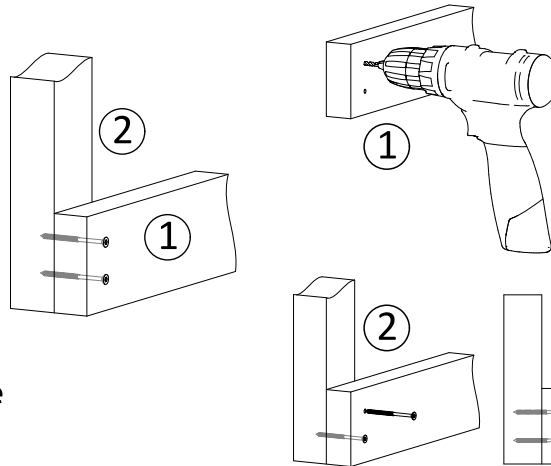

[EN] **Tools needed to provide before assembly.**  
 [FR] **Outils nécessaires à prévoir avant le montage.**  
 [NL] **Te voorziene gereedschappen bij aanvang van de montage.**  
 [DE] **Für die Montage notwendiges Werkzeug vorsehen.**  
 [IT] **Utensili necessari da prevedere prima del montaggio.**  
 [ES] **Preparar herramientas necesarias antes del montaje.**  
 [PT] **Prepare as ferramentas necessárias antes da montagem.**

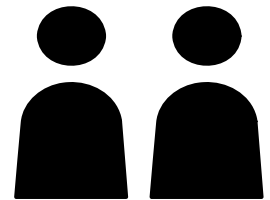
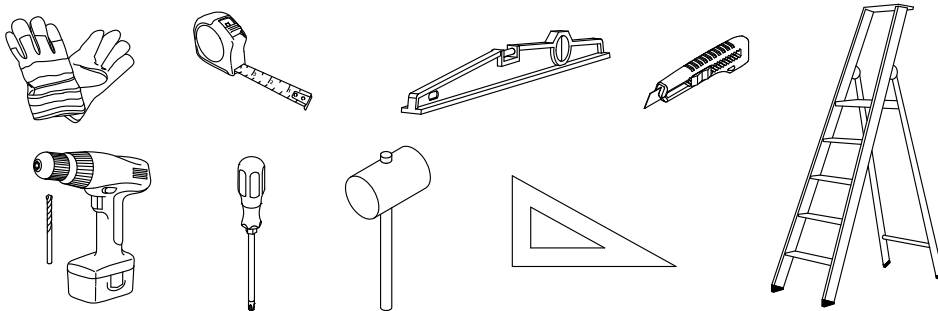

[EN] **2 persons**  
 [FR] **2 personnes**  
 [NL] **2 personen**  
 [DE] **2 Personen**  
 [IT] **2 persone**  
 [ES] **2 personas**  
 [PT] **2 pessoas**

[EN] **Significant complements not included.**  
 [FR] **Compléments importants non inclus.**  
 [NL] **Belangrijke aanvullingen niet inbegrepen.**  
 [DE] **Wichtige Zubehörteile nicht im Lieferumfang**  
 [IT] **Supplementi importanti non inclusi.**  
 [ES] **Complementos importantes no incluidos.**  
 [PT] **Complementos importantes não incluídos.**

Silicone / Mastic

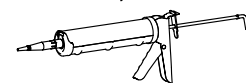

[EN] **Glue for the roof.**  
 [FR] **Colle pour le feutre bitumeux.**  
 [NL] **Lijm voor het dak.**  
 [DE] **Klebstoff für das Dach.**  
 [IT] **Colla per tela bitumata.**  
 [ES] **Pegamento para tela asfáltica.**  
 [PT] **Cola para tecido asfáltico.**

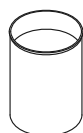

[EN] **Wood preserver for the outside : 2 layers before assembly.**  
 [FR] **Protection pour le bois en extérieur : 2 couches avant montage.**  
 [NL] **Bescherming van het hout: 2 lagen voor de montage.**  
 [DE] **Holzschutz für Aussenanwendung: 2 Lagen vor dem Zusammenbau.**  
 [IT] **Protezione per il legno in esterno : due mani prima del montaggio.**  
 [ES] **Protección para la madera de exteriores: 2 manos antes del montaje.**  
 [PT] **Proteção para madeira exterior: 2 demãos antes da montagem.**

# In-Out 2,66×0,98m

47244S000 - B-000070

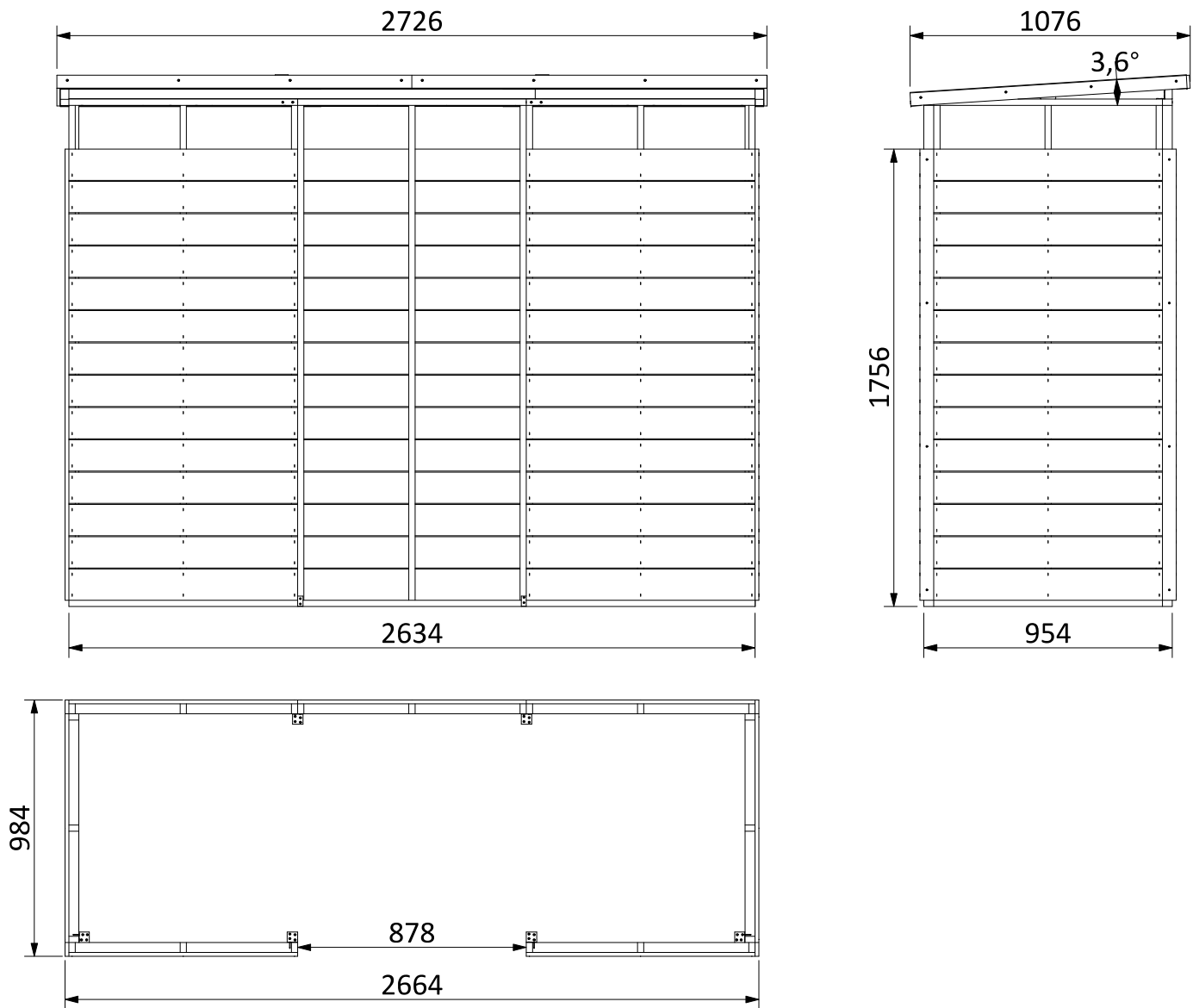

- [EN] Laying on a perfectly flat and level concrete slab (*not included*)
- [FR] Pose sur dalle béton parfaitement plate et de niveau (*non incluse*)
- [NL] Plaatsen op een perfect vlakke betontegel (*niet inbegrepen*)
- [DE] Montage auf einer ebenen, befestigten Fläche (*Material nicht inbegriffen*)
- [IT] Posare su pavimenti in cemento perfettamente in piano e livellato (*non incluso*)
- [ES] Colocar sobre losa de hormigón perfectamente plana y nivelada (*non incluida*)
- [PT] Montagem sobre laje de betão perfeitamente plana e nivelada (*não incluído*)

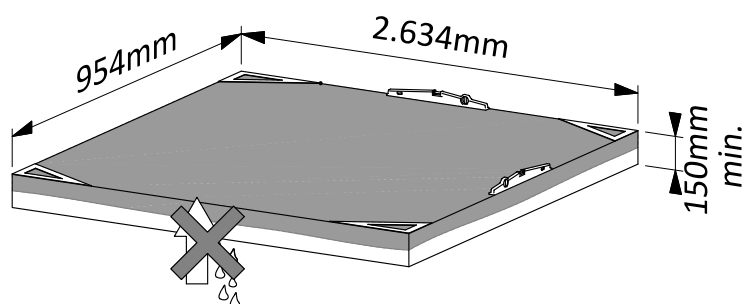

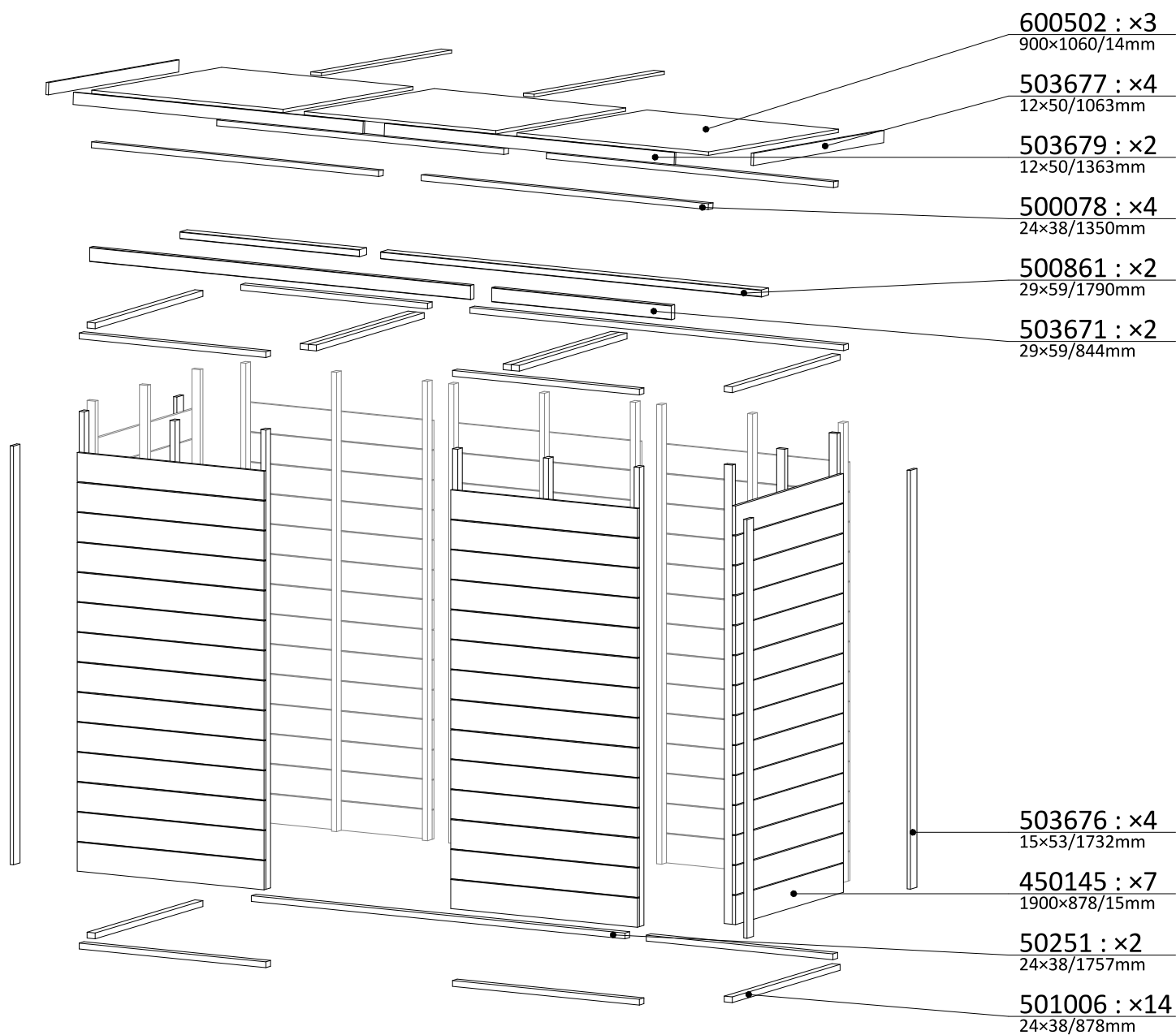

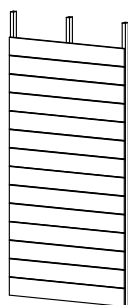

**450145 : 7**  
1900x878/15mm

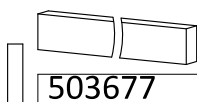



**503677 : 4**  
12x50/1063mm  
**503679 : 2**  
12x50/1363mm  
**503676 : 4**  
15x53/1732mm  
**500078 : 4**  
24x38/1350mm  
**50251 : 2**  
24x38/1757mm  
**501006 : 14**  
24x38/878mm  
**500861 : 2**  
29x59/1790mm  
**503671 : 2**  
29x59/844mm



**600502 : 3**  
900x1060/14mm

**Kit 700370**

	3012	ø3,5x25mm	68
	3014	ø3,5x35mm	20
	3023	ø4x40mm	48
	3025	ø4x50mm	45
	3027	ø4x60mm	86
			
	2915	ø4mm	1

**Kit 700361 : x2**

	2386	15x32x32/2,mm	5
---	------	---------------	---

**Kit 700210 : x3**

	2382	40x40x40/1,5mm	6
---	------	----------------	---

**Kit 700043**

	3810	ø2x15mm	69
---	------	---------	----

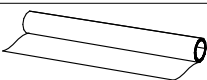
	1,5mm	
800030	1,00x4,50m	1

**1**

450145 : x3  
1900x878/15mm

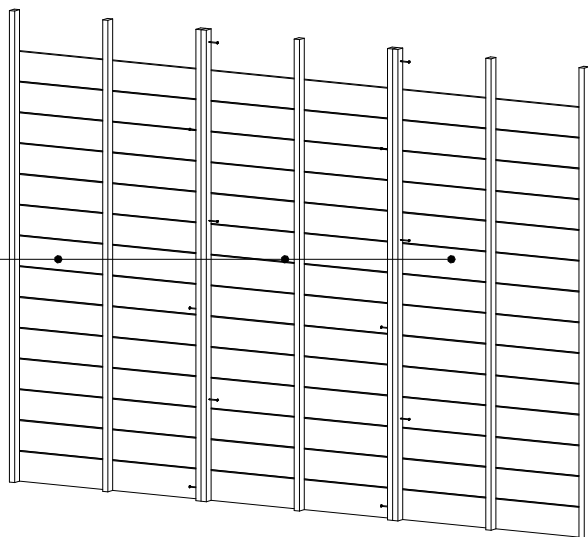

3023 : x3  
ø4x40

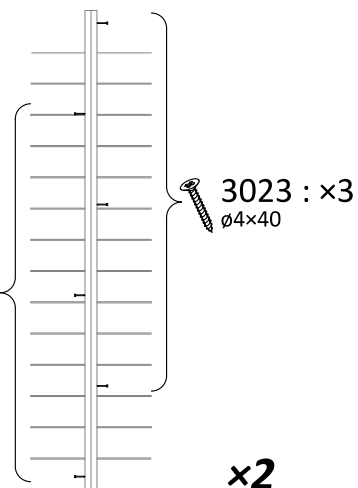

x2

501006  
24x38/878mm  
+ 3027 : x3  
ø4x60

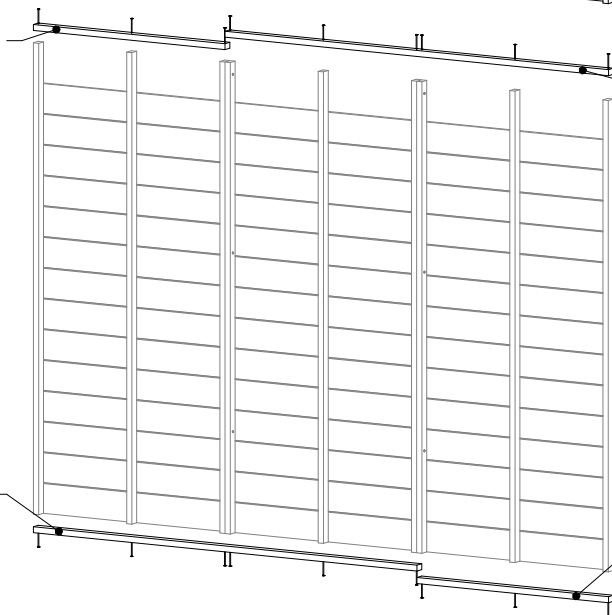

50251  
24x38/1757mm  
+ 3027 : x6  
ø4x60



=A

50251  
24x38/1757mm  
+ 3027 : x6  
ø4x60

501006  
24x38/878mm  
+ 3027 : x3  
ø4x60

**2**



501006  
24x38/878mm  
+ 3027 : x3  
ø4x60

x2

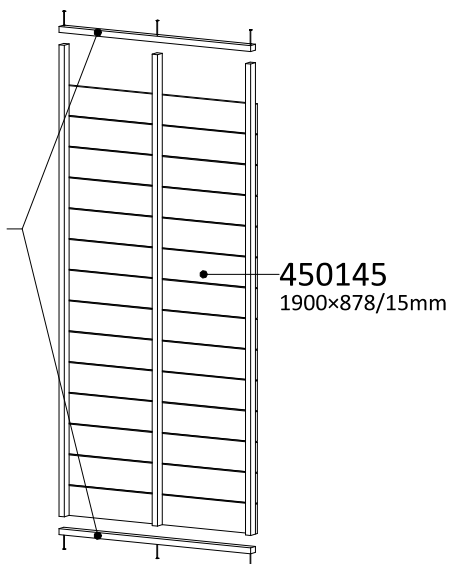

450145  
1900x878/15mm

x4

=B

=C

=D

=E

3

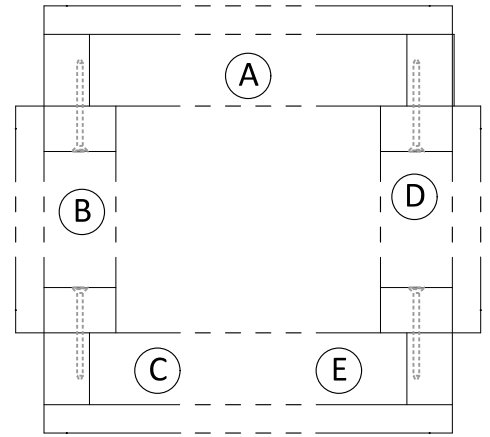
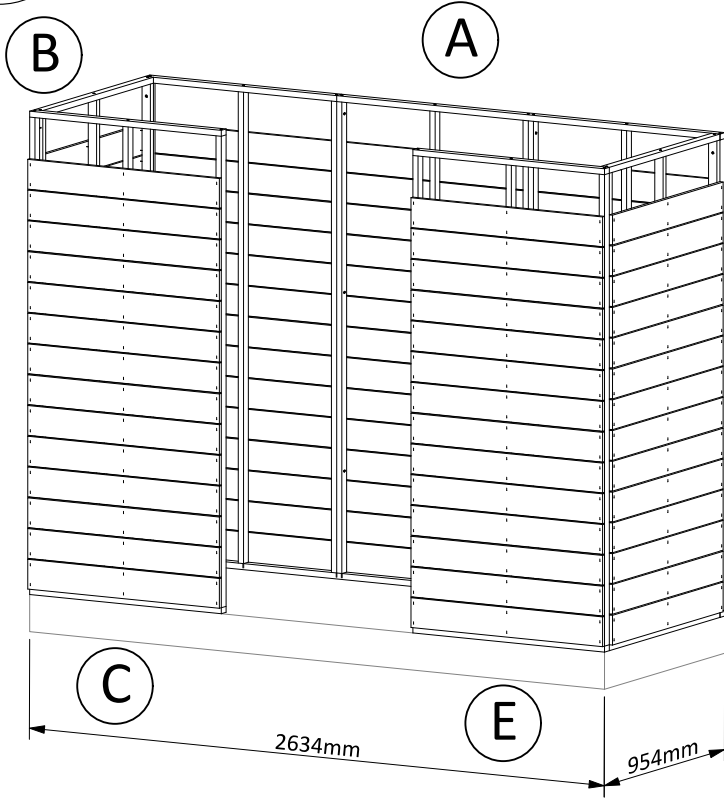

D

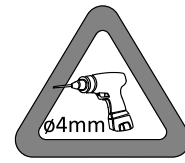

3025 : x6  
 ø4x50

x4

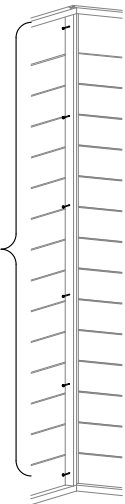

4

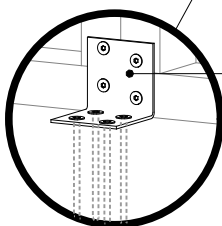
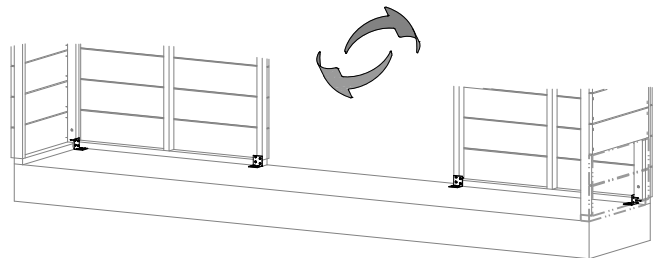
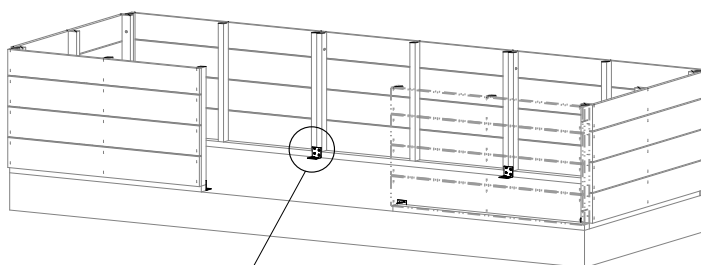
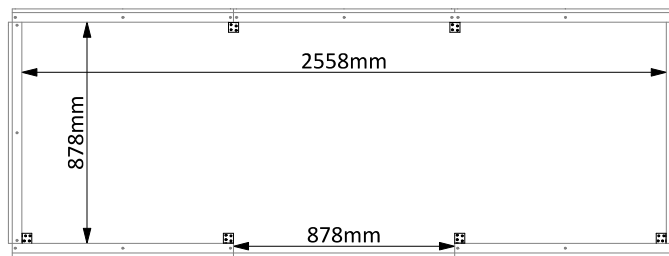

2382

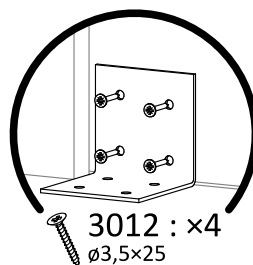

3012 : x4  
 ø3,5x25

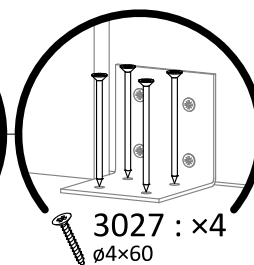

3027 : x4  
 ø4x60



[EN] not included  
 [FR] non incluse  
 [NL] niet inbegrepen  
 [DE] nicht einbegriffen  
 [IT] non incluso  
 [ES] non incluida  
 [PT] não incluído

x6

# 5

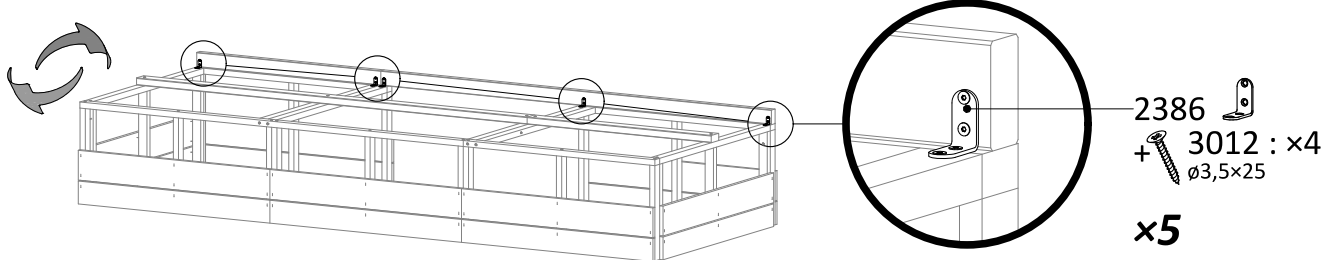
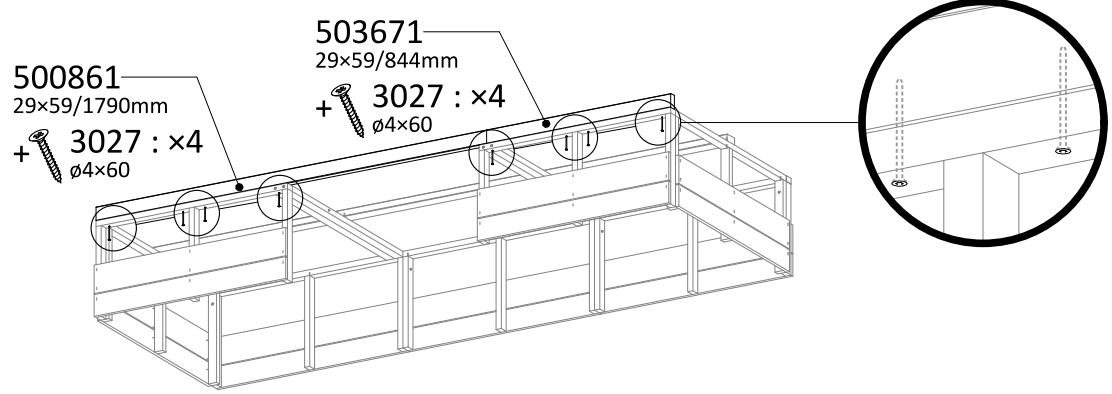
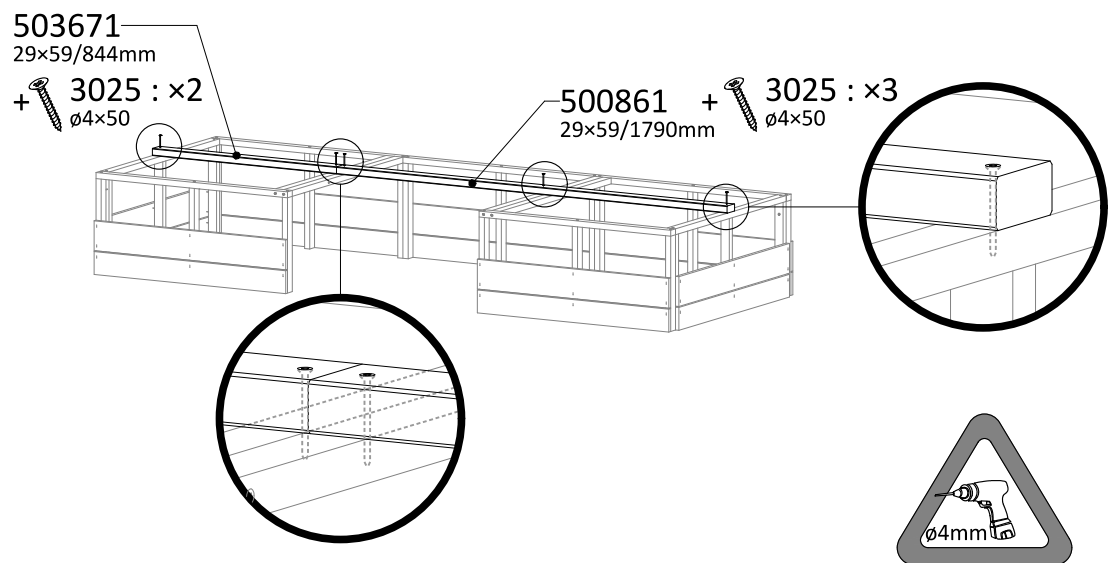
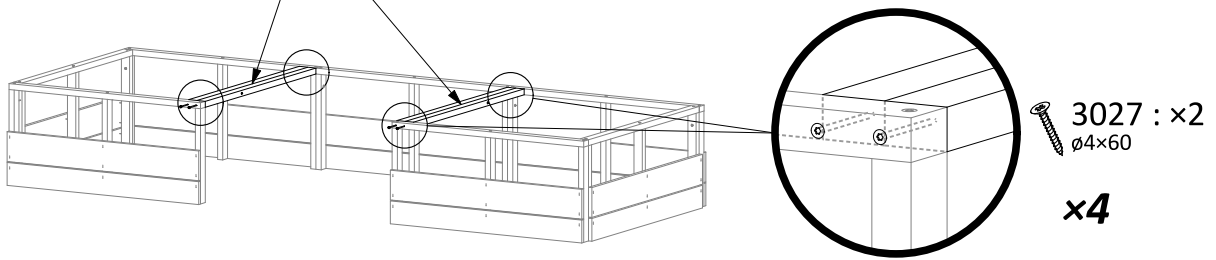
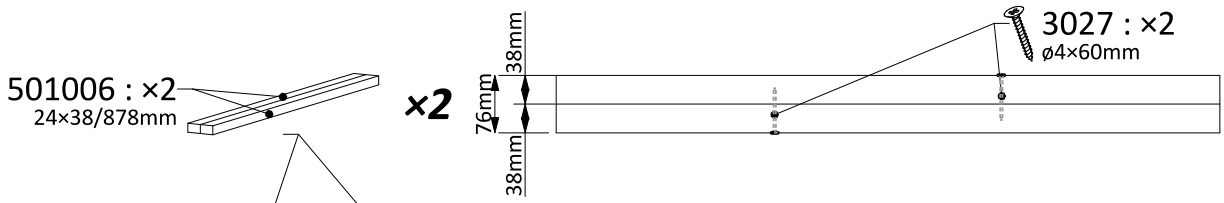



6

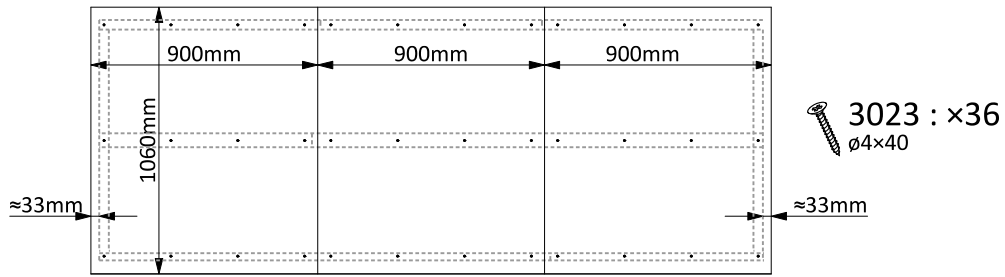
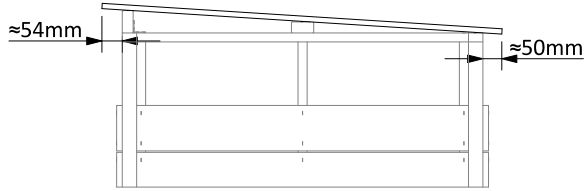
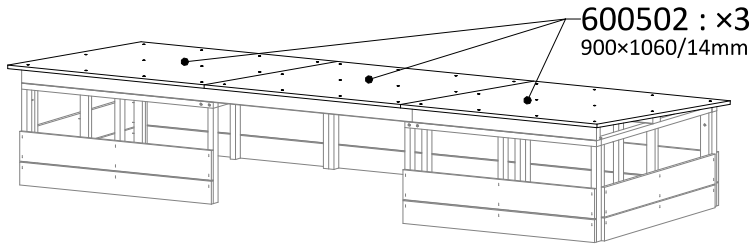

7

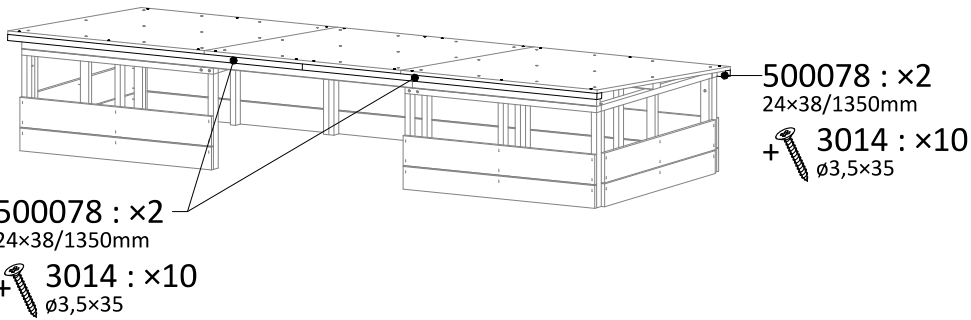

500078 : x2  
24x38/1350mm  
+ 3014 : x10  
ø3,5x35

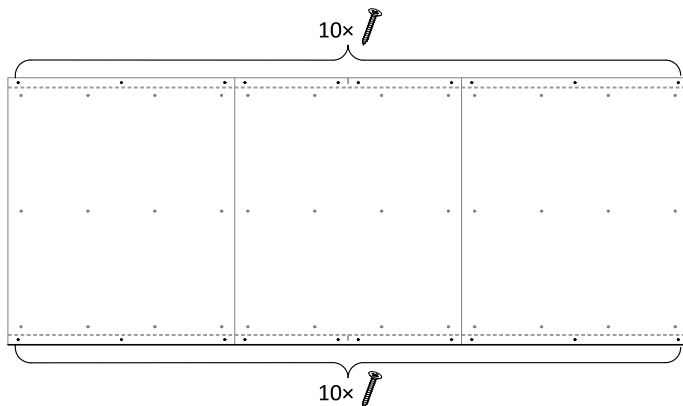

8

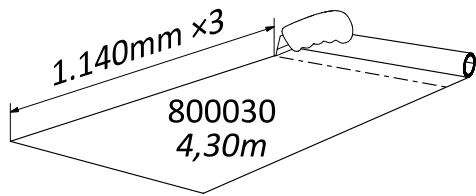

[EN] not included  
[FR] non incluse  
[NL] niet inbegrepen  
[DE] nicht einbegriffen  
[IT] non incluso  
[ES] non incluida  
[PT] não incluído

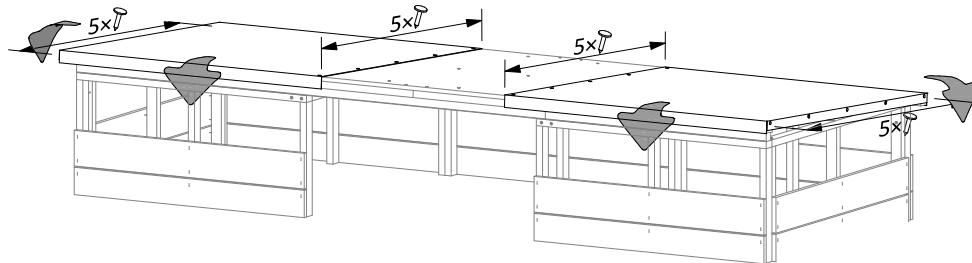

+  3810 : x20  
15mm

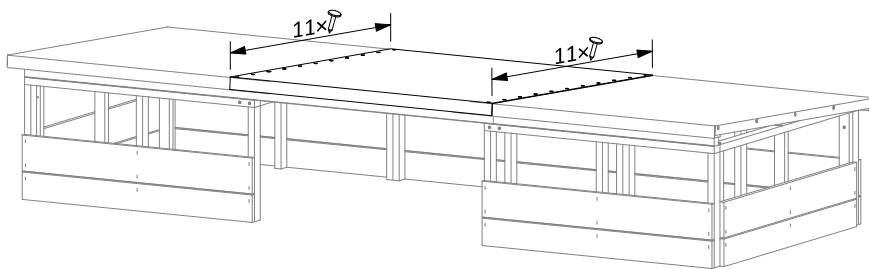

+  3810 : x22  
15mm

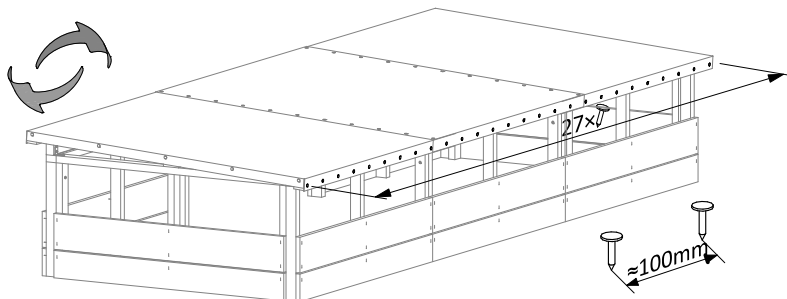

+  3810 : x27  
15mm

= 69 

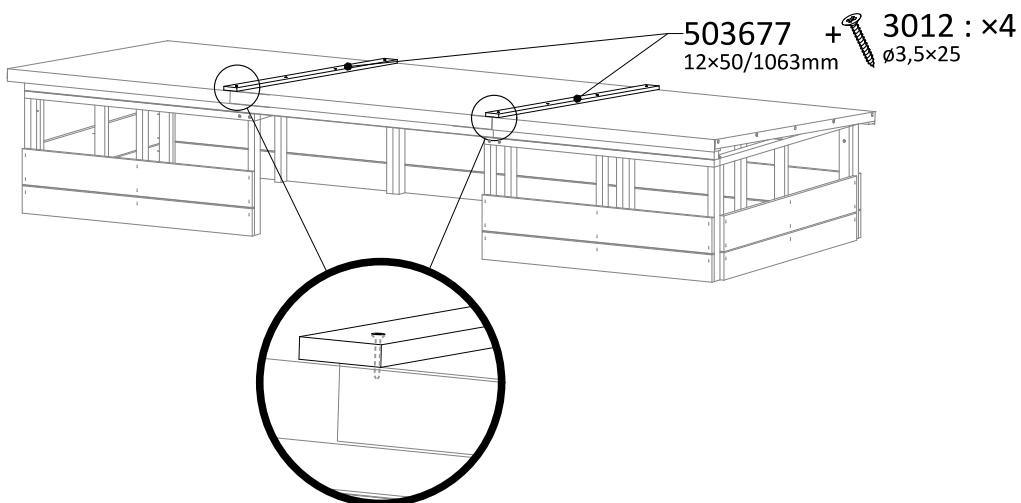

9

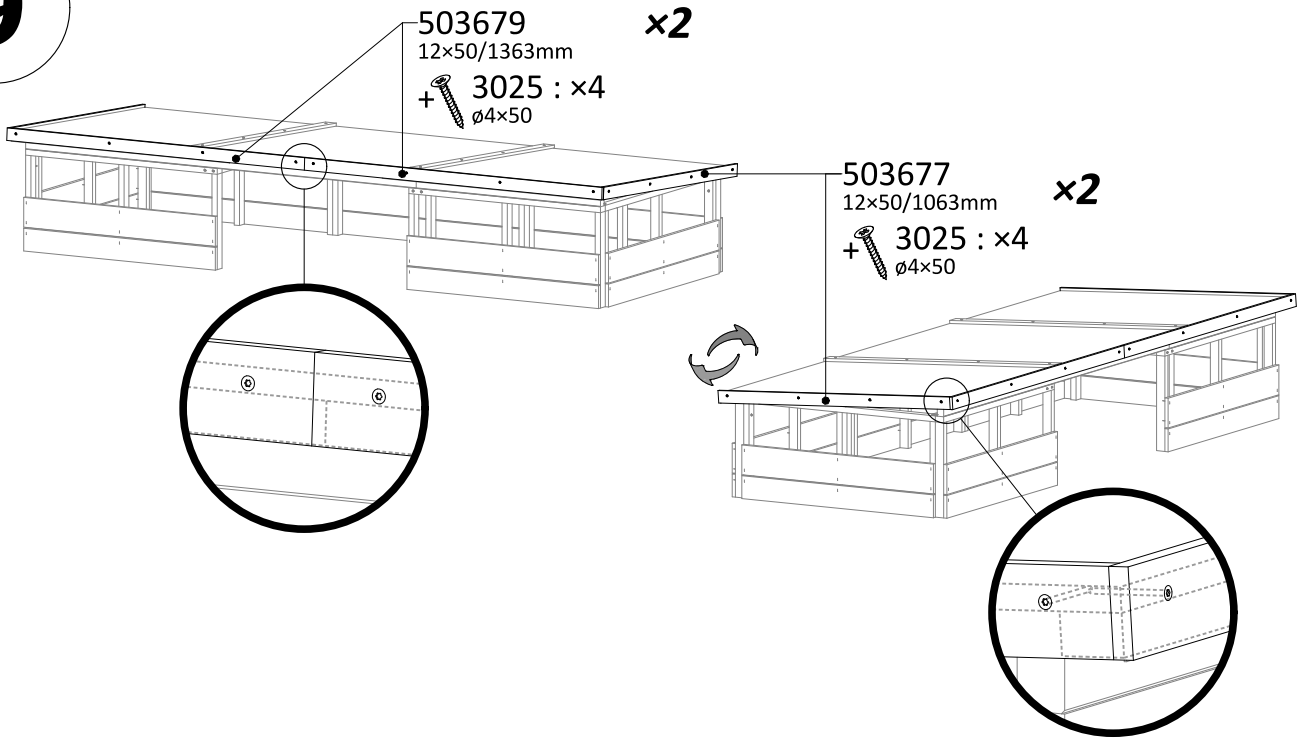

10

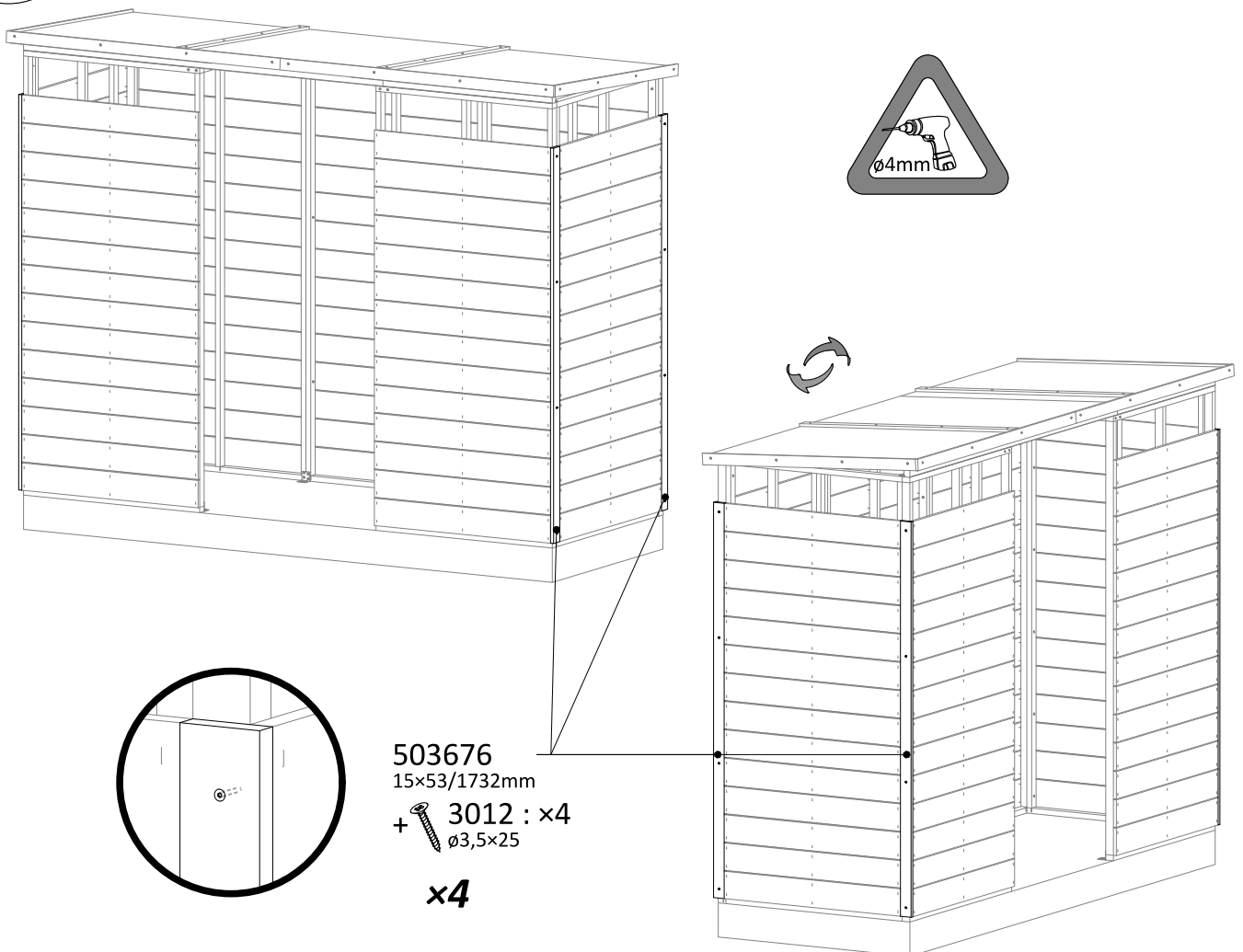

- [EN] **Unique warranty number, must be send for any request.**
- [FR] **Numéro de garantie unique, à transmettre obligatoirement pour toute demande.**
- [NL] **Uniek garantienummer, dat voor alle aanvragen moet worden verstrekt.**
- [DE] **Eindeutige Garantienummer, muss bei jeder Anfrage gesendet werden.**
- [IT] **Numero di garanzia unico, da trasmettere obbligatorio per ogni richiesta.**
- [ES] **Numero único de garantía, se transmitirá obligatoriamente para todas las solicitudes.**
- [PT] **Número de garantia único, será transmitido obrigatoriamente para todas as solicitações.**

Fabriqué par Décor et Jardin  
Parc Industriel - Rue Nazareth 13  
4651 Battice - Belgique  
e-mail : [info@decoretjardin.com](mailto:info@decoretjardin.com)  
website : [www.decoretjardin.com](http://www.decoretjardin.com)

