



PRODUCT DATA SHEET

DGI 02.06.02

REFERENCE

DESCRIPTION

REV

DATE

WR000578

CNX-Li 5220 IQ BATTERY ROBOT - for pool up to 10x5m

0

05/05/2023

CHARACTERISTICS

BAR CODE EAN13: 9317545295800

CLEANER SIZE: 43 x 40 x 30 cm

CLEANER WEIGHT: 9,2 kg

CLEANED WIDTH: ? cm

CYCLE TIME: ?? h FILTRATION: 100 µ

ELECTRIC WEIGHT: ? Kg - TRANSFORMATOR WEIGHT: ?? Kg

BATTERY LIFE: 1 full cycle CHARGING TIME: 7-8 h

POWER SUPPLY: ? - STEERING: ?

SUCTION SYSTEM: MECHANICAL SUCTION : ?

DISPLACEMENT SPEED: ? m/min



PACKAGING

UNITS: 1

PACKAGE SIZE: 32 x 39 x 32 cm

PACKAGE VOLUME: 0,04 m³

GROSS WEIGHT: 18,5 kg

NET WEIGHT: 1,6 kg

BOX WEIGHT: ? kg

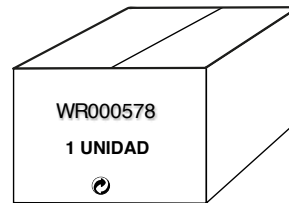

PALETS

PALET SIZE: 112 x 112 x 15 cm

TOTAL SIZE PALET: 112 x 112 x 205 cm

TOTAL VOLUME: 2,57 m³

UNITS PALET: 20

PACKAGES PALET: 20

4 ROWS ON THE PALET x 5 BOXES X ROW

PALET LABEL IDENTIFICATION

TOTAL WEIGHT INCLUDED PALET: 330 kg

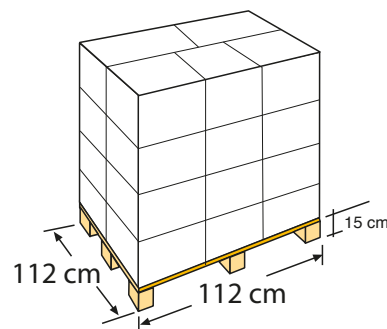

NOTES

iAqualink control: charging info, End-of cycle notification, preset of the cleaning mode, + Smart mode & Waterline only modes