

BACK COVER - 210 mm

FRONT COVER - 210 mm

INNER SIDE - FOLD (BLANK) - 205 mm

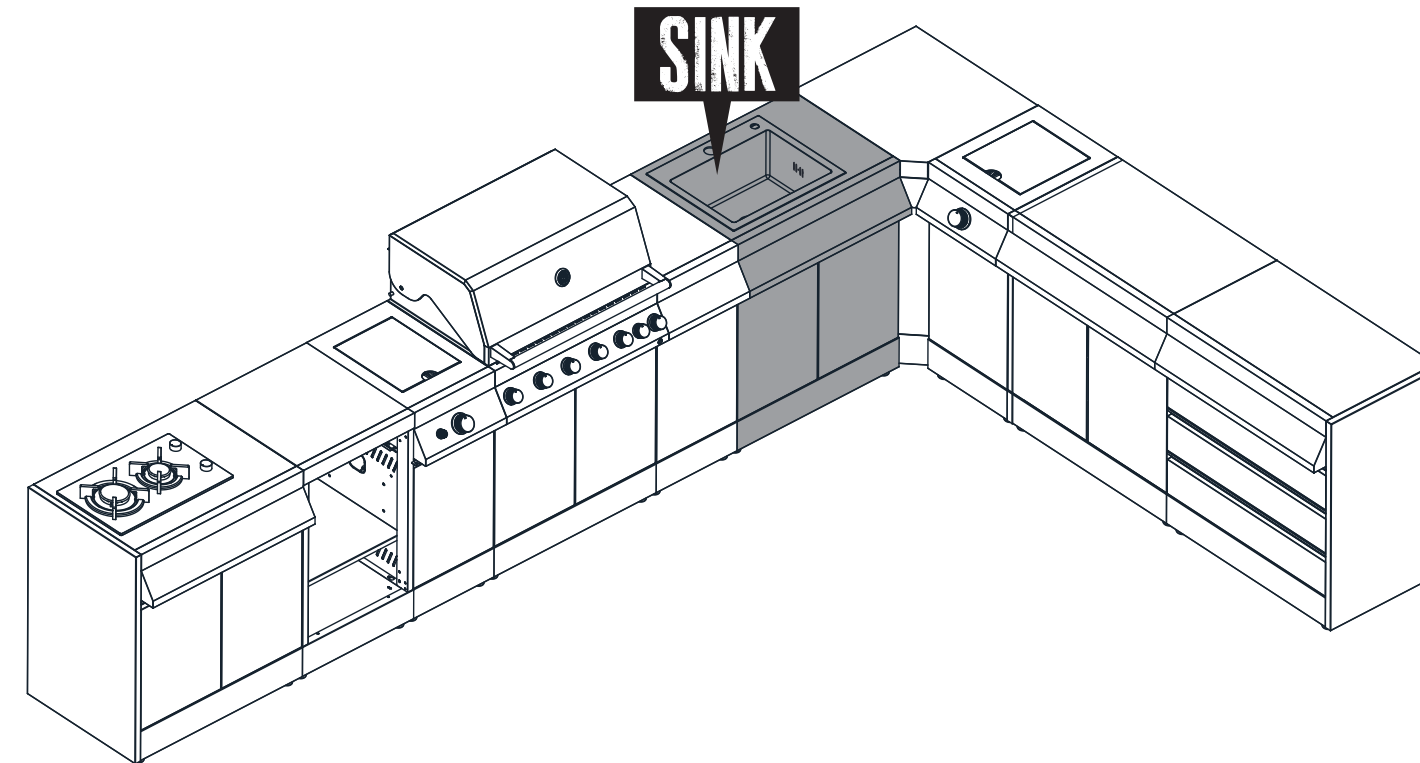

- DE Montageanleitung
- EN Assembly instructions
- NL Montageaanwijzing
- CZ Návod k instalaci
- SK Návod na inštaláciu

- HR Upute za montažu
- SI Navodila za postavitv
- HU Összeszerelési utasítás
- DK Montagevejledning

INSIDE 1 - FOLD (DETAIL DRAWING) - 205 mm

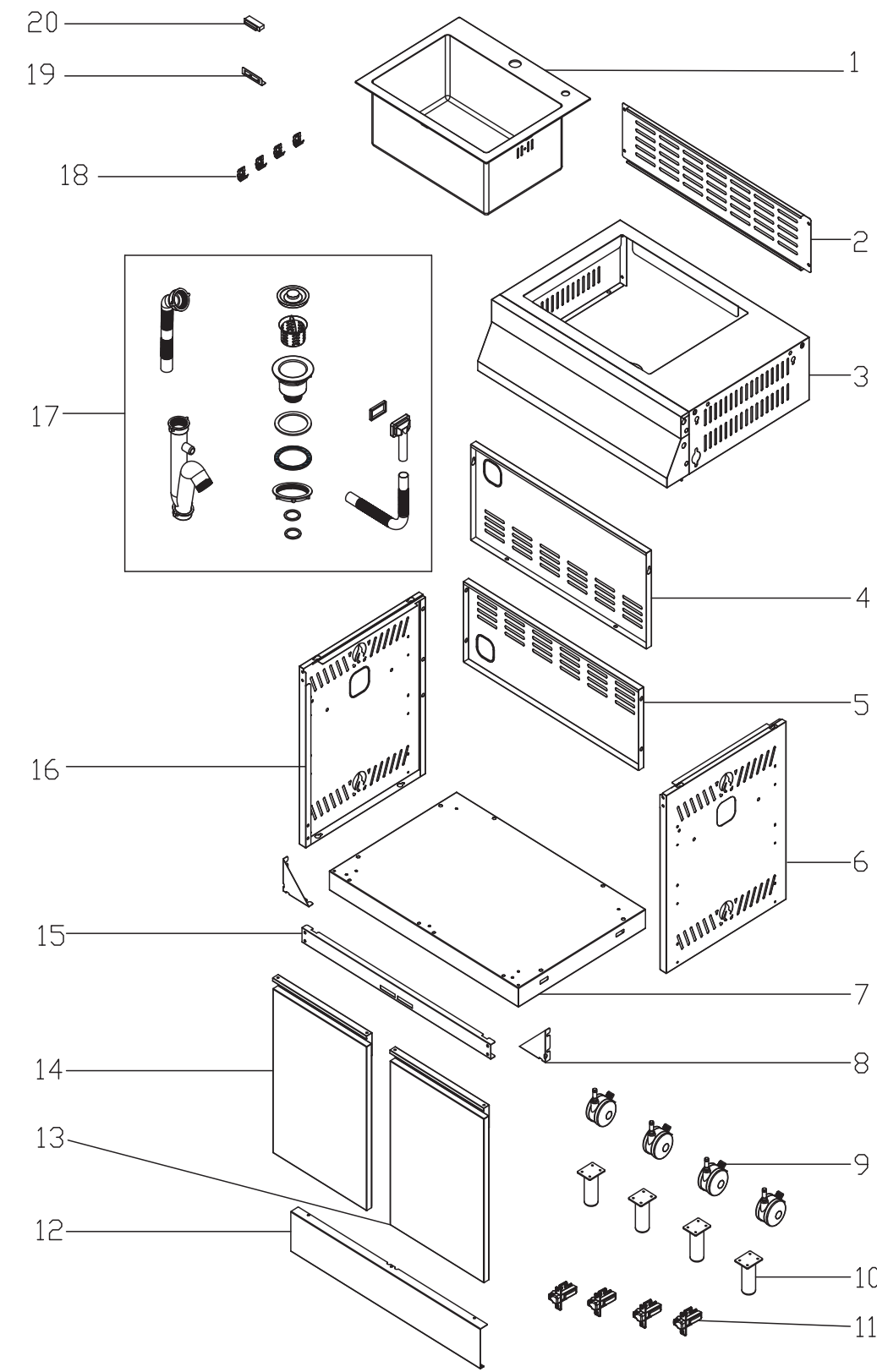

21 (Set)

A	B	C	D	E	F	G	H
10 x 1/4"-20	41 x 5/32"-32 4 x	-	-	2 x 5/32"-32	-	-	2 x 2 x

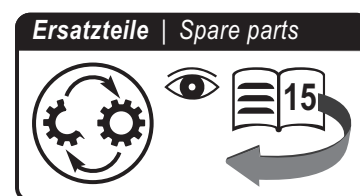

INSIDE 2 - 210 mm

DE

Nr.	Bezeichnung	Menge	Nr.	Bezeichnung	Menge
1	Waschbecken	1	11	Türscharnier	4
2	Rückwand	1	12	Untere Dekorationsleiste	1
3	Arbeitsfläche	1	13	Tür rechts	1
4	Obere Rückwand	1	14	Tür links	1
5	Untere Rückwand	1	15	Rahmen vorne	1
6	Seitenteil, rechts	1	16	Seitenteil, links	1
7	Bodenblech	1	17	Abwasserleitung	1
8	Stabilisierungswinkel	2	18	Befestigungsklammern	4
9	Laufrollen	4	19	Halterung für Türmagnet	1
10	Fuss höhenverstellbar	4	20	Tür-Magnet	1

Stellen Sie sicher, dass Sie Ihren Grill korrekt montiert haben. Befolgen Sie dazu die einzelnen Schritte der detaillierten Montageanleitung.

Achtung: Wir legen großen Wert auf einen möglichst einfachen Montageprozess. Die Metallteile wurden nach der Produktion entgratet, jedoch können scharfe Kanten Verletzungen verursachen. Daher empfehlen wir beim Umgang mit den Teilen während der Montage Schutzhandschuhe zu tragen.

EN

No.	Appellation	Qty	No.	Appellation	Qty
1	Sink	1	11	Door Hinge	4
2	Sink Countertop Rear Seal Plate	1	12	Decorative Frame of Bottom Panel	1
3	Sink Countertop Assembly	1	13	Right Door	1
4	Top Rear Panel of the Body	1	14	Left Door	1
5	Rear Panel of the Body	1	15	Body Front Beam	1
6	Right Side Panel of the Body	1	16	Body Left Side Panel	1
7	Sink Body Bottom Plate	1	17	Sewer Assembly	1
8	Triangle Bracket	2	18	Sink Fixing Tab	4
9	Brake Wheel	4	19	Door Suction Seat	1
10	Foot Support	4	20	Door Magnet	1

Make sure your grill is assembled properly. Detailed assembly instructions are packed with each grill giving specific assembly procedures for each model. Follow these instructions carefully to ensure the correct and safe assembly of the grill.

Caution: Although we take every effort to ensure that the assembly process is as easy as possible, it is inherent with fabricated steel parts that corners and edged can cause cuts if improperly handled during assembly procedures. Be careful while handling any parts during assembly. It is strongly recommended that you protect hands with a pair of work gloves.

Made for:
garbou GmbH
Dornaper Strasse 18
42327 Wuppertal
Germany

INSIDE 3 - LAST PAGE (DECLARATION OF CONFORMITY) - 210 mm



NL

Nr.	Omschrijving	Aantal	Nr.	Omschrijving	Aantal
1	Wasbak	1	11	Deurscharnier	4
2	Achterwand	1	12	Onderste decoratiestrip	1
3	Werkblad	1	13	Deur rechts	1
4	Bovenste achterwand	1	14	Deur links	1
5	Onderste achterwand	1	15	Frame, vooraan	1
6	Zij-element, rechts	1	16	Zij-element, links	1
7	Bodemplaat	1	17	Afvalwaterleiding	1
8	Stabilisatie-hoekelement	2	18	Bevestigingsklemmen	4
9	Wieltjes	4	19	Houder voor deurmagneet	1
10	Poot in hoogte verstelbaar	4	20	Deurmagneet	1

Verzekert U, dat U Uw grill correct heeft gemonteerd.

Volgt U daarvoor de afzonderlijke stappen van de gedetailleerde montageaanwijzing op.

Opgelet: Wij hechten grote waarde aan een zo mogelijk eenvoudig montageproces.

De metaaldelen werden na de productie ontbraamd, echter kunnen scherpe kanten blessures veroorzaken.

Daarom raden wij bij de omgang met de delen gedurende de montage het dragen van veiligheidshandschoenen aan.

CZ

Č.	Název	Množství	Č.	Název	Množství
1	Umyvadlo	1	11	Závěs dveří	4
2	Zadní stěna	1	12	Spodní dekorační lišta	1
3	Pracovní plocha	1	13	Dveře vpravo	1
4	Horní zadní stěna	1	14	Dveře vlevo	1
5	Spodní zadní stěna	1	15	Rám vpředu	1
6	Boční díl, vpravo	1	16	Boční díl, vlevo	1
7	Spodní plech	1	17	Kanalizační potrubí	1
8	Stabilizační úhelník	2	18	Upevňovací svorky	4
9	Kolečka	4	19	Držák pro magnet dveří	1
10	Výškově nastavitelná noha	4	20	Magnet dveří	1

Ujistěte se, že Váš grill byl smontován správně. K tomu respektujte jednotlivé kroky detailního návodu na montáž.

Pozor: Velký důraz klademe na co možná jednoduchý montážní proces.

Kovové díly byly po výrobě zbaveny otřepů, avšak ostré hrany mohou způsobit zranění.

Proto doporučujeme při zacházení s díly během montáže nosit ochranné rukavice.

Made for:
garbou GmbH
Dornaper Strasse 18
42327 Wuppertal
Germany

SK

Č. dielu	Označenie	Množstvo	Č. dielu	Označenie	Množstvo
1	Umývadlo	1	11	Záves dvierok	4
2	Zadná stena	1	12	Spodná dekoračná lišta	1
3	Pracovná plocha	1	13	Dvierka vpravo	1
4	Horná zadná stena	1	14	Dvierka vľavo	1
5	Spodná zadná stena	1	15	Rám, vpredu	1
6	Bočný diel, vpravo	1	16	Bočný diel, vľavo	1
7	Plech dna	1	17	Odtokové potrubie	1
8	Stabilizačný uholník	2	18	Upevňovacie svorky	4
9	Pojazdné kolieska	4	19	Držiak pre dverový magnet	1
10	Noha výškovo nastaviteľná	4	20	Dverový magnet	1

Uistite sa, že bol Váš gril zmontovaný správne. K tomu rešpektujte jednotlivé kroky detailného návodu na montáž.

Pozor: Veľký dôraz kladieme na čo najjednoduchší montážny proces.

Kovové diely boli po výrobe zbavené ostrapkov, avšak ostré hrany môžu spôsobiť zranenia.

Preto odporúčame pri zaobchádzaní s dielmi počas montáže nosiť ochranné rukavice.

HR

Br.	Oznaka	Količina	Br.	Oznaka	Količina
1	Umivaonik	1	11	Šarka za vrata	4
2	Stražnja stjenka	1	12	Donja dekoracijska letva	1
3	Radna ploča	1	13	Vrata desno	1
4	Gornja stražnja stjenka	1	14	Vrata lijevo	1
5	Donja stražnja stjenka	1	15	Okvir sprijeda	1
6	Bočni dio, desno	1	16	Bočni dio, lijevo	1
7	Podni lim	1	17	Odvod za otpadnu vodu	1
8	Stabilizirajući kutnik	2	18	Stezaljke za pričvršćivanje	4
9	Kotačići za kretanje	4	19	Držać magneta za vrata	1
10	Nožica podesiva po visini	4	20	Magnet za vrata	1

Uvjerite se da je Vaš plinski roštilj ispravno montirali.

Slijedite u tu svrhu pojedinačne korake detaljnih uputa za montažu.

Oprez: Veliko značenje pridajemo što jednostavnijem postupku montaže. Metalni dijelovi su nakon proizvodnje bili izgladeni, ipak oštri rubovi mogu prouzročiti ozljede. Stoga preporučujemo kod rukovanja s dijelovima tijekom montaže nositi zaštitne rukavice.

Made for:
garbou GmbH
Dornaper Strasse 18
42327 Wuppertal
Germany

SI

Št.	Ime	Količina	Št.	Ime	Količina
1	Korito	1	11	Tečaj za vrata	4
2	Hrbtna stena	1	12	Spodnja dekorativna letev	1
3	Delovna površina	1	13	Vrata desno	1
4	Zgornja hrbtna stena	1	14	Vrata levo	1
5	Spodnja hrbtna stena	1	15	Okvir, spredaj	1
6	Stranski del, desno	1	16	Stranski del, levo	1
7	Talna plošča	1	17	Cev za odpadno vodo	1
8	Stabilizacijski kotnik	2	18	Pritrdilne sponke	4
9	Kolesca	4	19	Držalo za magnet za vrata	1
10	Noga, višinsko nastavljiva	4	20	Magnet za vrata	1

Prepričajte se, da ste pravilno namestili žar. Sledite posameznim korakom podrobnih navodil za namestitvev.

Pozor: Velik pomen pripisujemo čim enostavnejšemu postopku namestitve.

Kovinski deli so bili po proizvodnji obrušeni, vendar lahko ostri robovi povzročijo poškodbe.

Zato priporočamo, da pri rokovanju z deli med montažo nosite zaščitne rokavice.

HU

Cikkszám	Megnevezés	Mennyiség	Cikkszám	Megnevezés	Mennyiség
1	Mosdókagyló	1	11	Ajtópánt	4
2	Hátfal	1	12	Alsó dekorációs lécz	1
3	Munkalap	1	13	Jobb ajtó	1
4	Felső hátfal	1	14	Bal ajtó	1
5	Alsó hátfal	1	15	Keret elől	1
6	Jobb oldalsó rész	1	16	Bal oldalsó rész	1
7	Fenéklemez	1	17	Szennyvízvezeték	1
8	Stabilizáló kengyel	2	18	Rögzítő kapcsok	4
9	Görgők	4	19	Az ajtómagnes tartója	1
10	Magasságában állítható láb	4	20	Ajtómagnes	1

Ügyeljen arra, hogy a grillt megfelelően szerelje össze.

Kövesse ehhez az összeszerelési útmutatás egyes lépéseit.

Figyelem: Nagy gondot fordítunk az összeszerelés lehető legegyszerűbb folyamatára.

A gyártás után az acélarabok sárjázva lettek, de éles sarkok sérülést okozhatnak.

Emiatt a készülék összeszerelése során kesztyű használata ajánlott.

Made for:
garbou GmbH
Dornaper Strasse 18
42327 Wuppertal
Germany



Nr.	Betegnelse	Antal	Nr.	Betegnelse	Antal
1	Vask	1	11	Hængsel	4
2	Bagvæg	1	12	Pynteliste fornedet	1
3	Arbejdsflade	1	13	Låge, højre	1
4	Øverste bagvæg	1	14	Låge, venstre	1
5	Nederste bagvæg	1	15	Ramme, foran	1
6	Sidedel, højre	1	16	Sidedel, venstre	1
7	Bundplade	1	17	Spildevandsledning	1
8	Stabiliseringsvinkel	2	18	Fastgørelsesklemmer	4
9	Hjul	4	19	Holder til dørmagnet	1
10	Fod, højdejusterbar	4	20	Dørmagnet	1

Kontroller, at du har monteret grillen korrekt.

Følg de enkelte anvisninger i den detaljerede montagevejledning.

Advarsel: Vi lægger stor vægt på, for at gøre montage så nem som muligt.

Metaldelene blev udglattet efter produktion, kan dog skarpe kanter forårsage skader.

Derfor anbefales det ved behandling af dele at bruge beskyttelseshandsker under montage.

1.



Option A

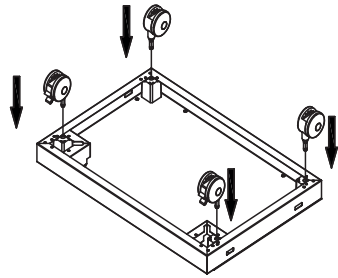

Hinweis: Bei der Montage von Laufrollen ist es später nicht möglich die unteren und seitlichen Blenden zu montieren, da sich die Rollen nicht frei drehen könnten.

Note: When mounting the caster wheels, it will not be possible to mount the bottom decoration panels and side decoration panels later on, as the wheels would not be able to rotate freely.

Option B

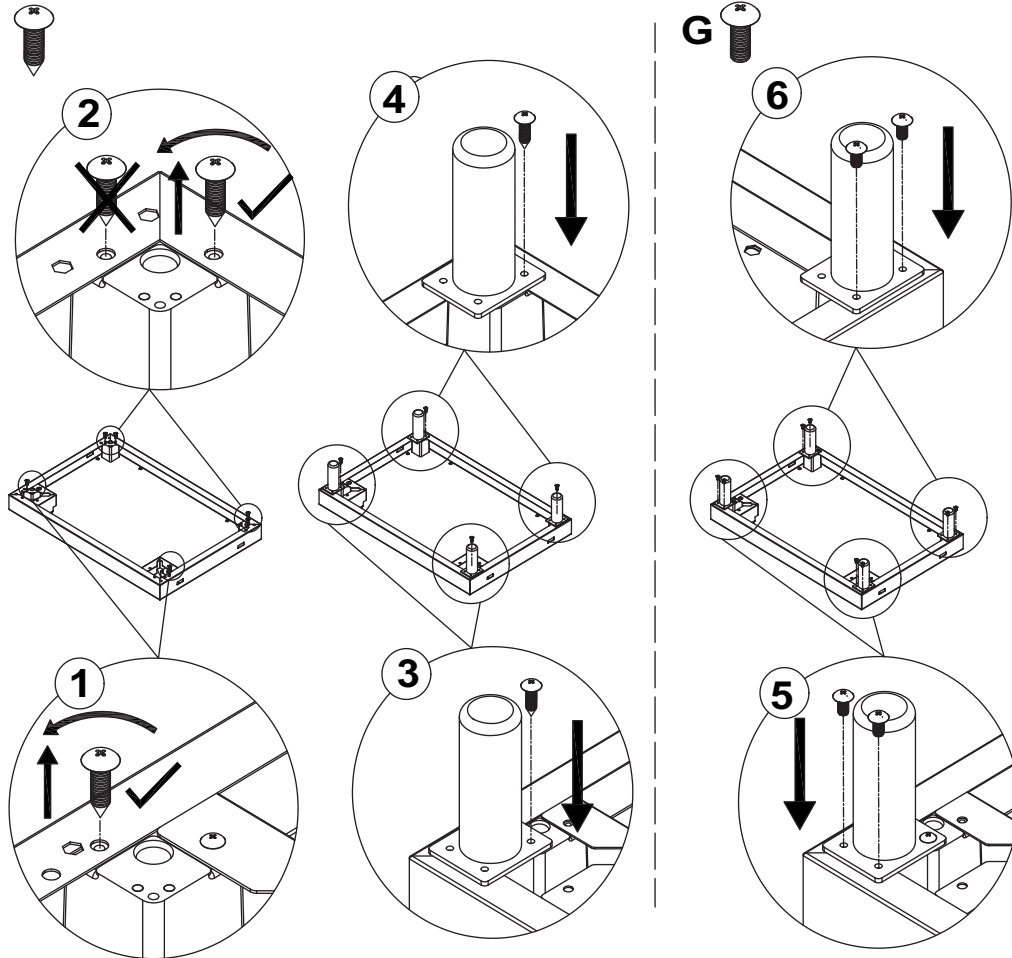

2.

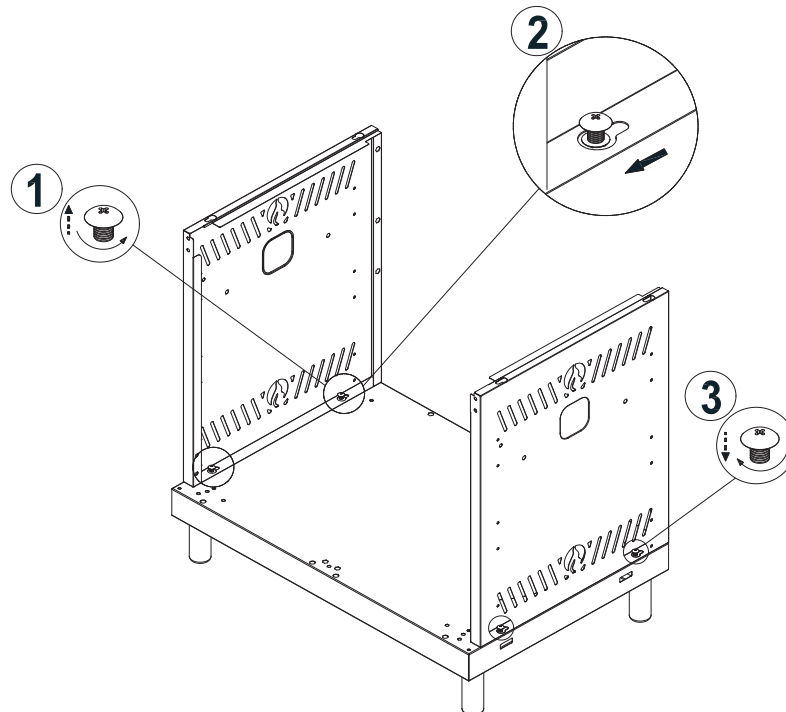

3.

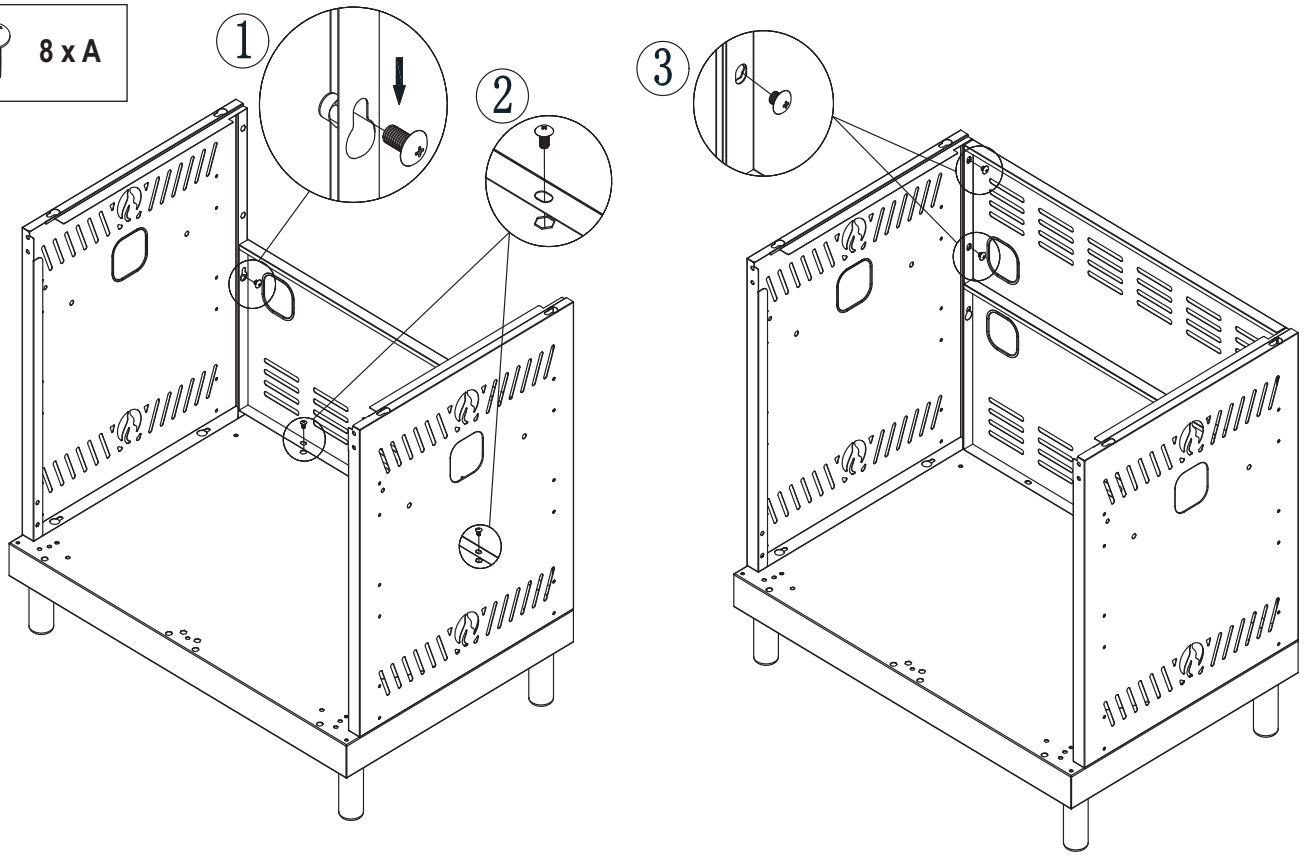

4.

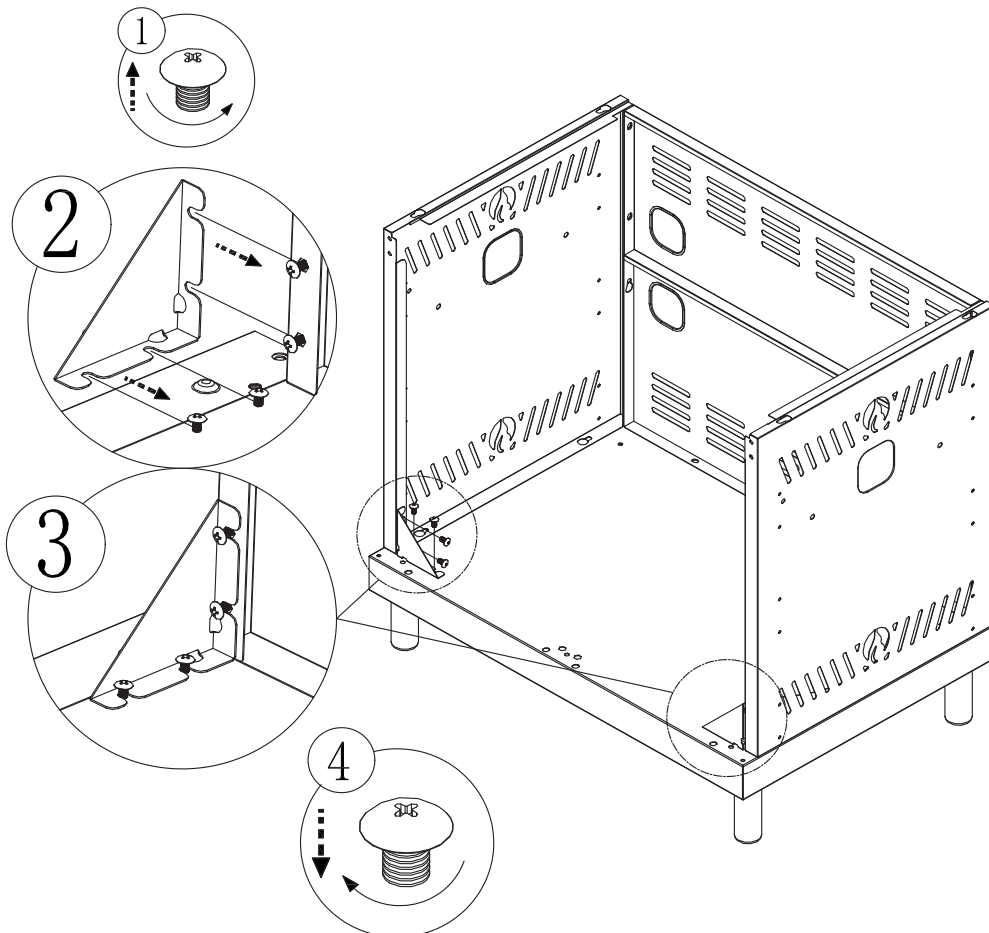

5.

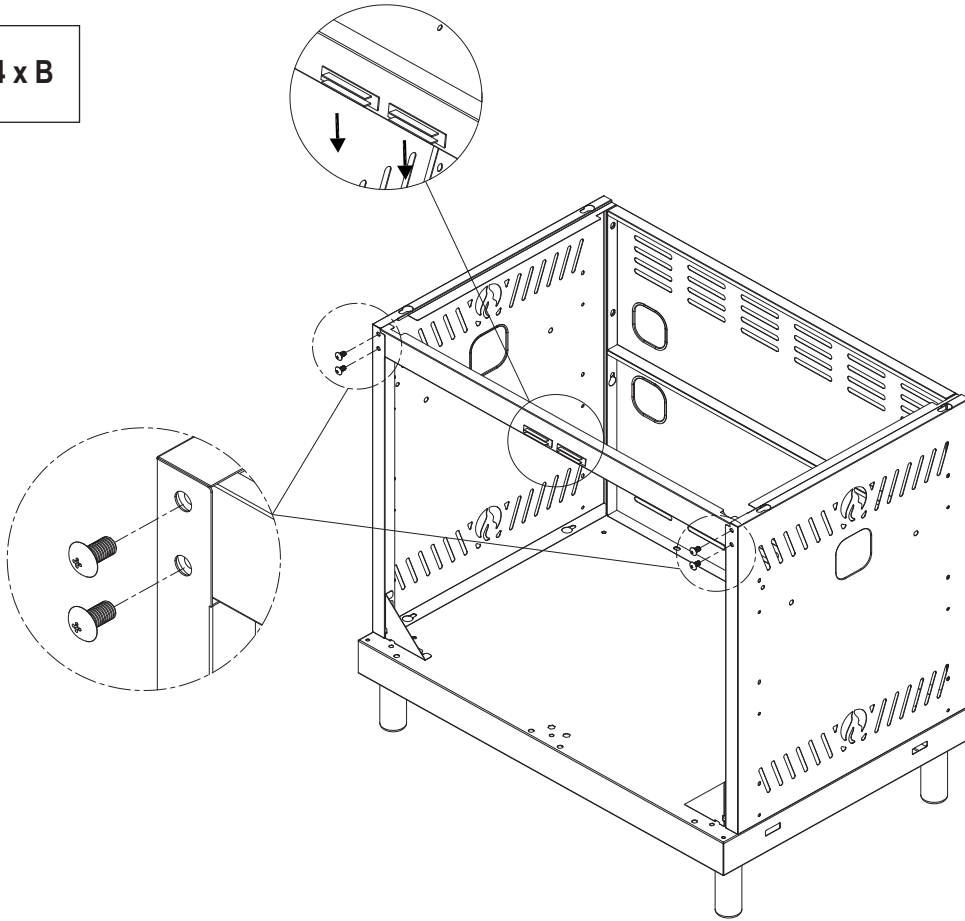

6.

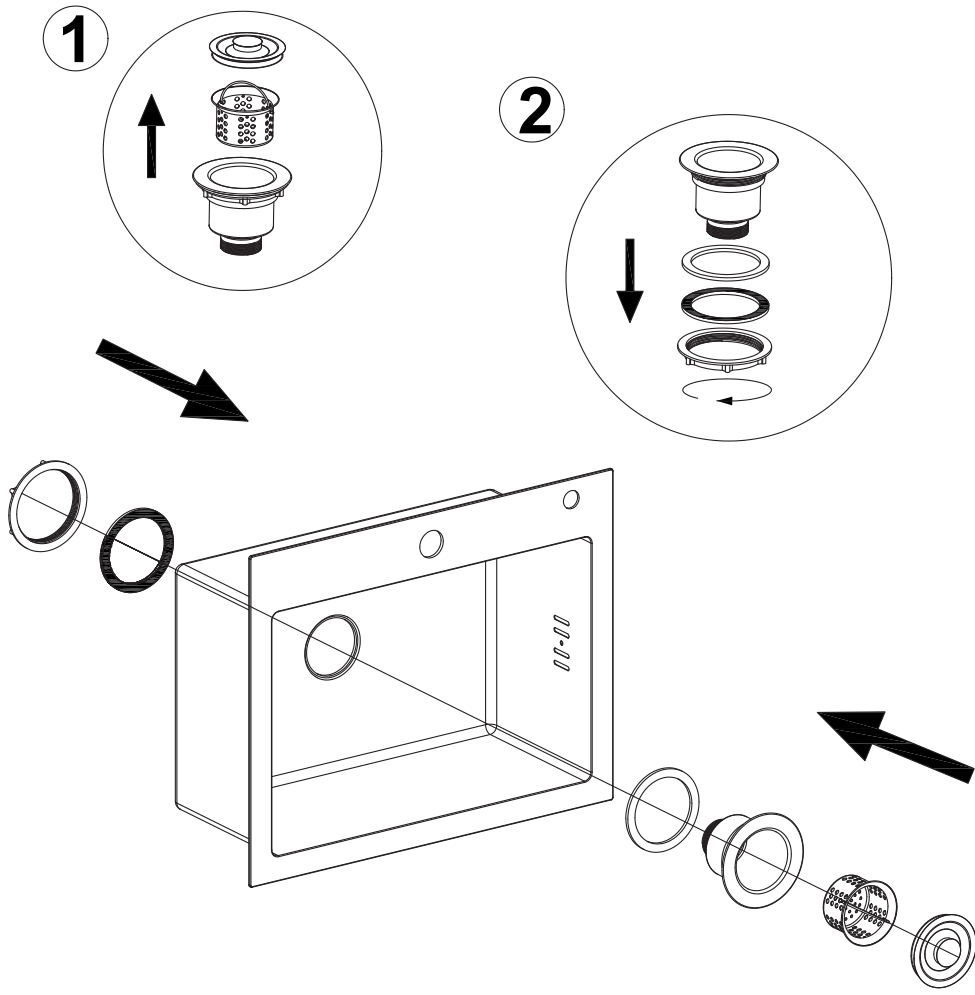

7.

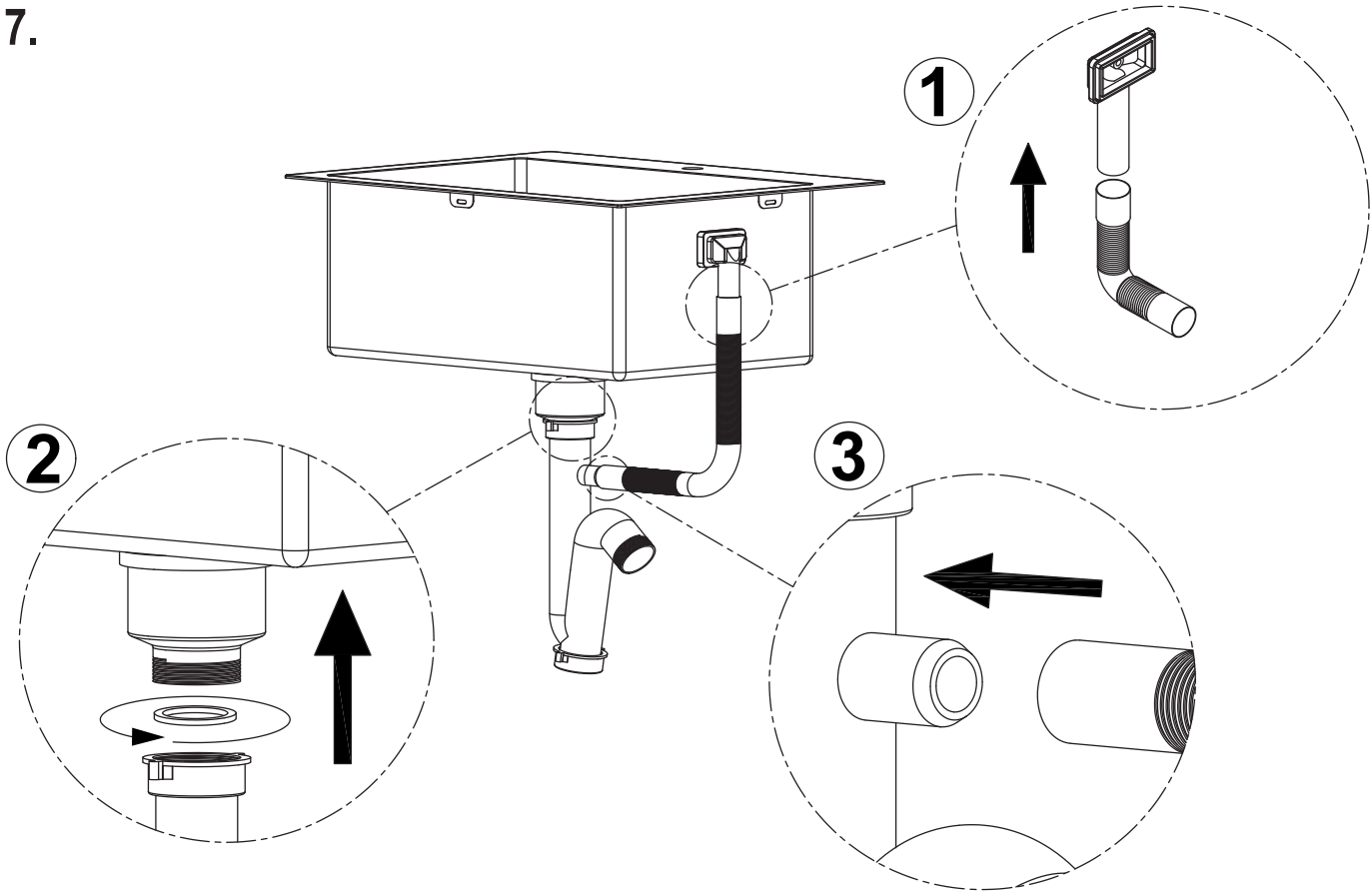

8.

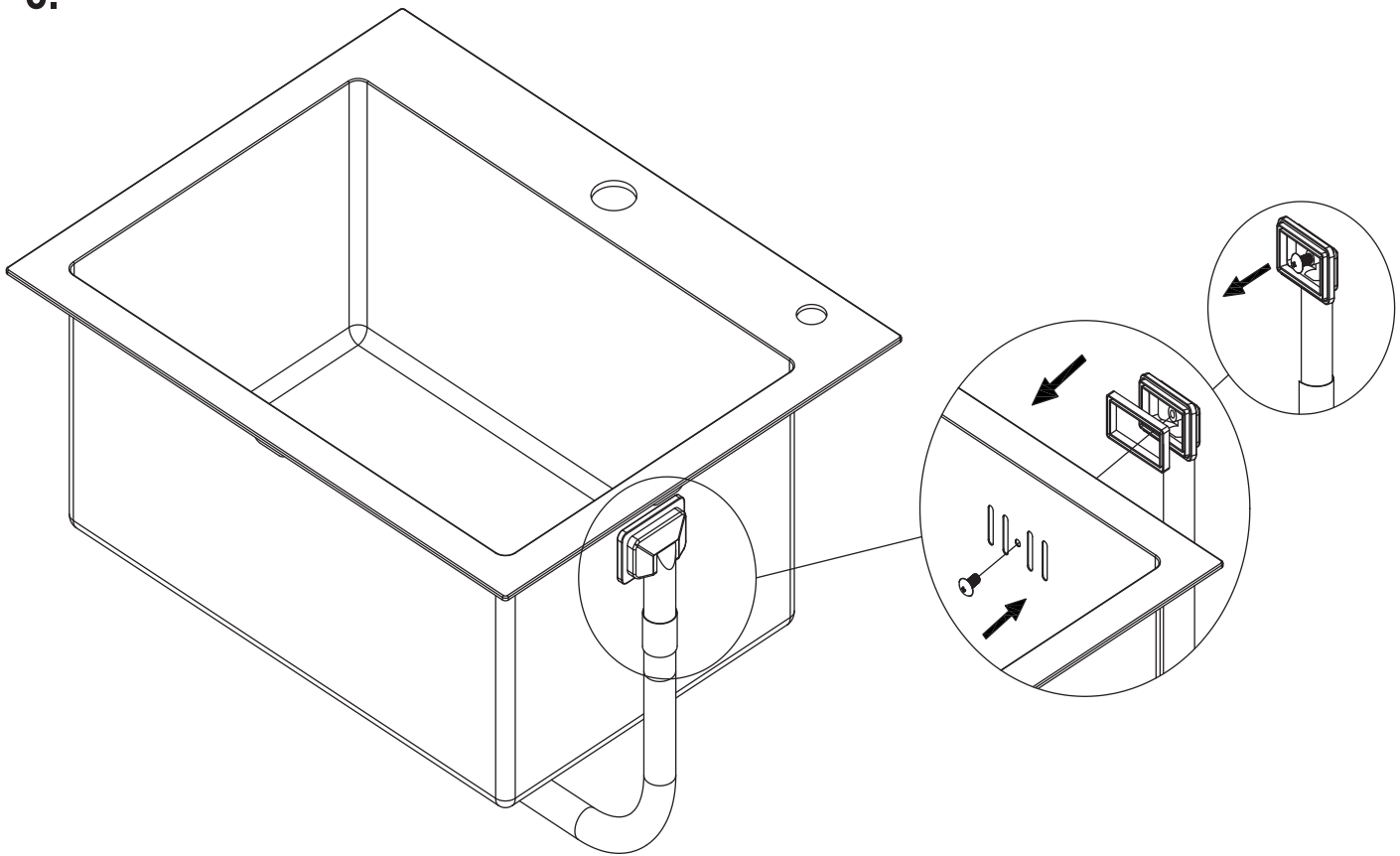

9.

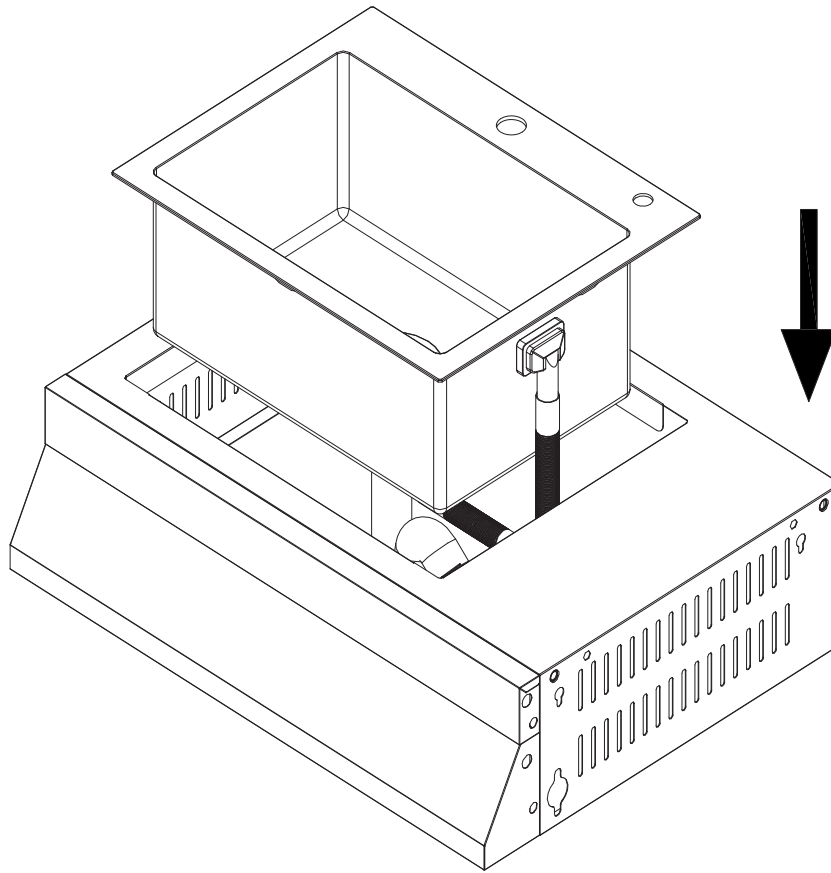

10.

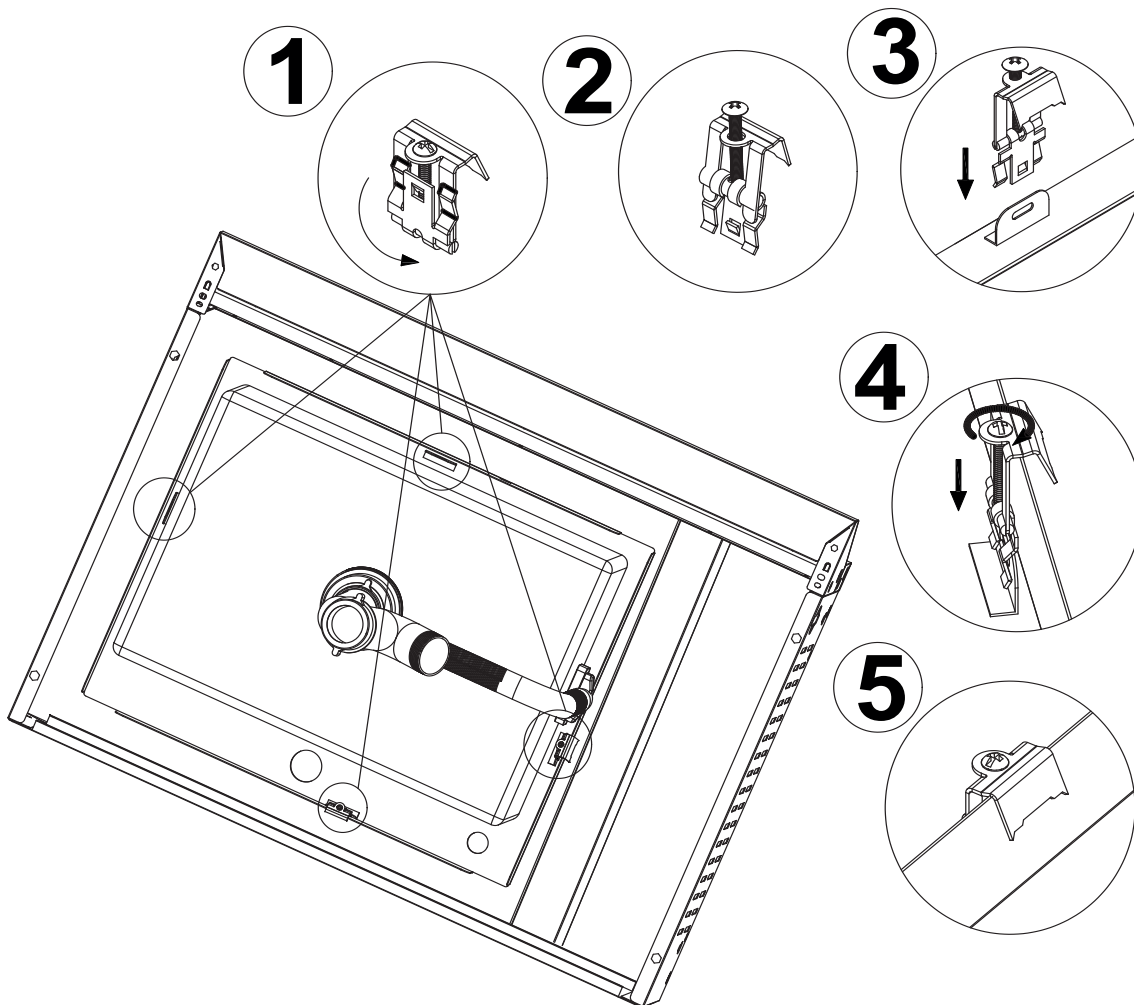

11.

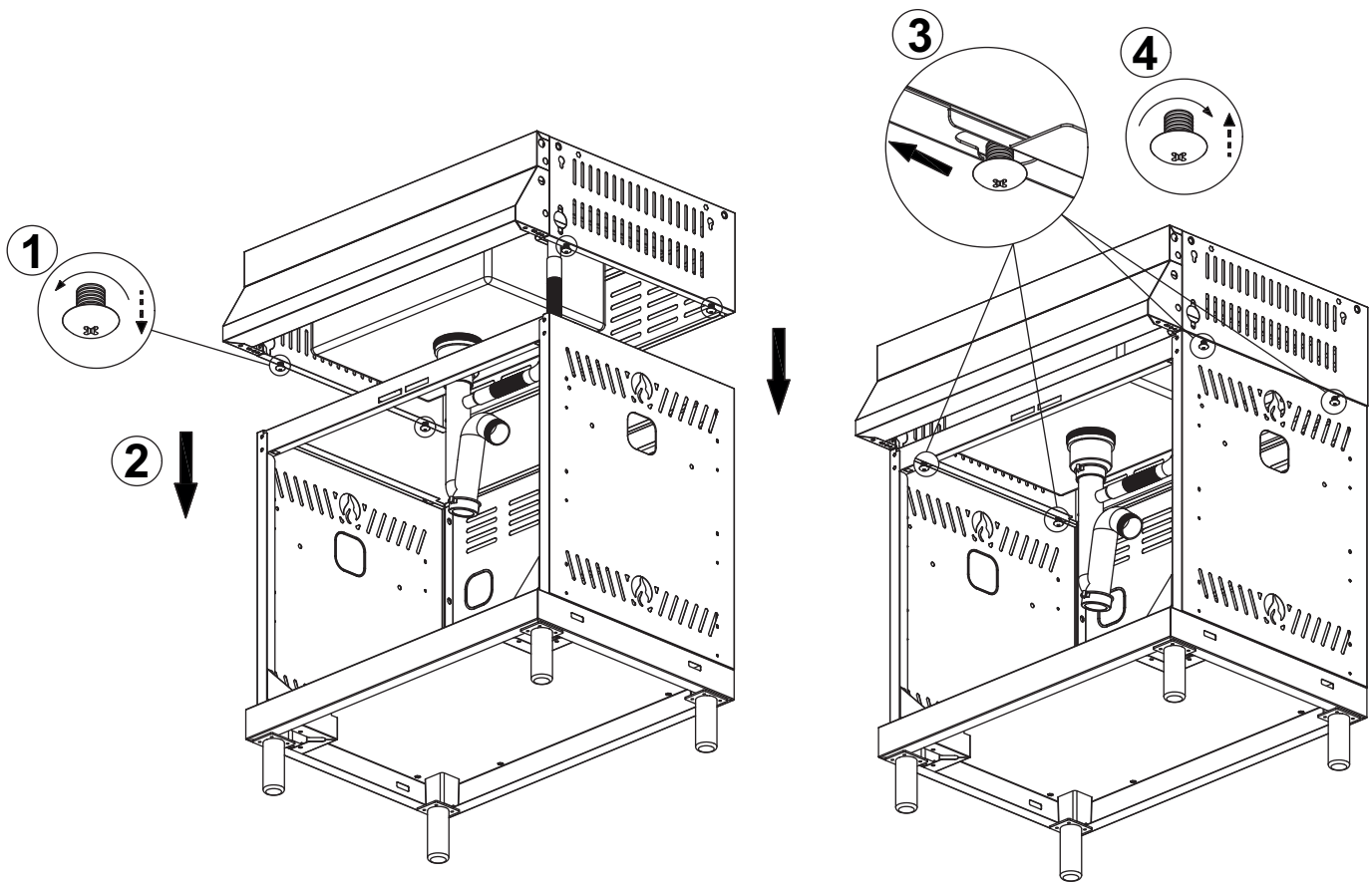

12.

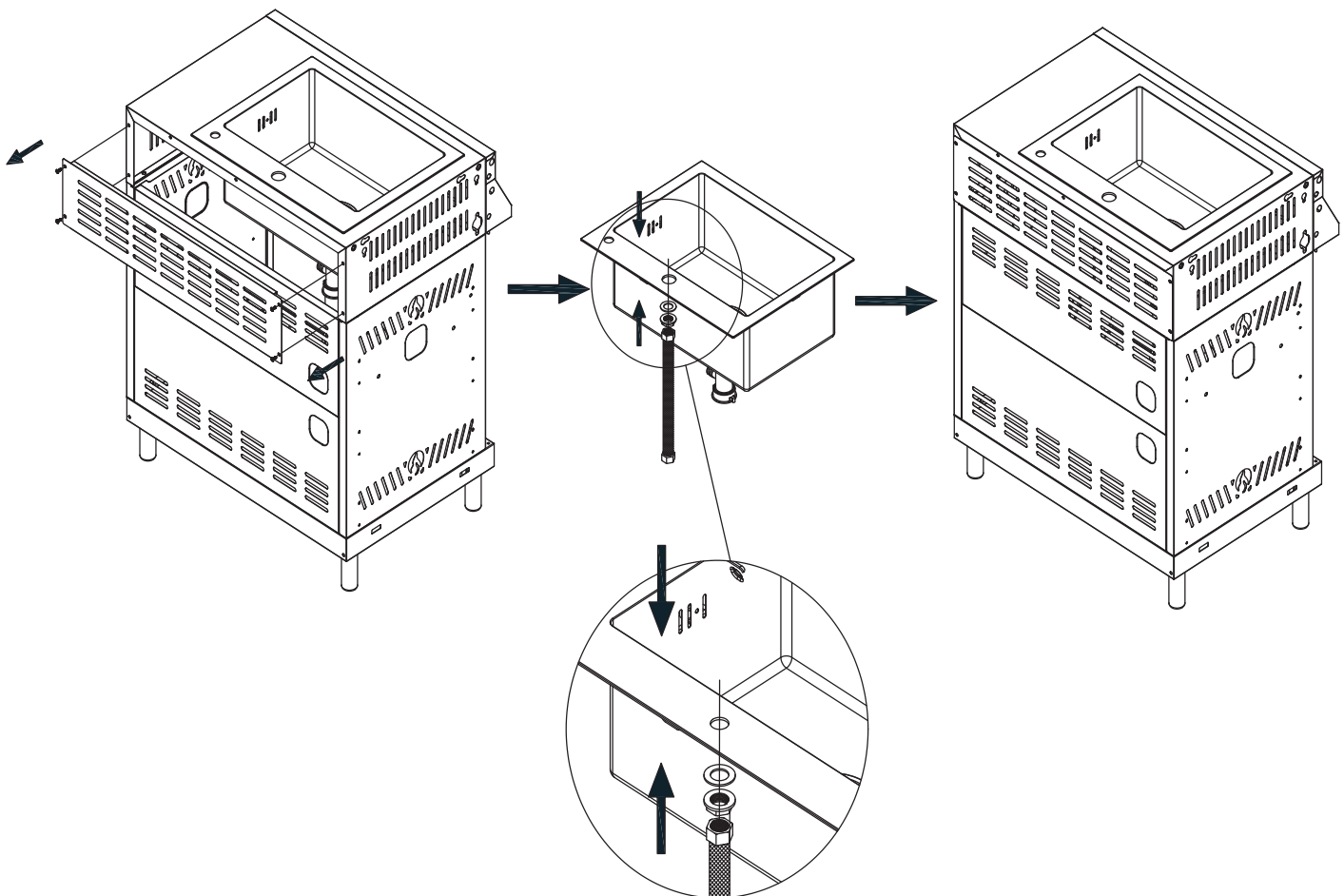

13.

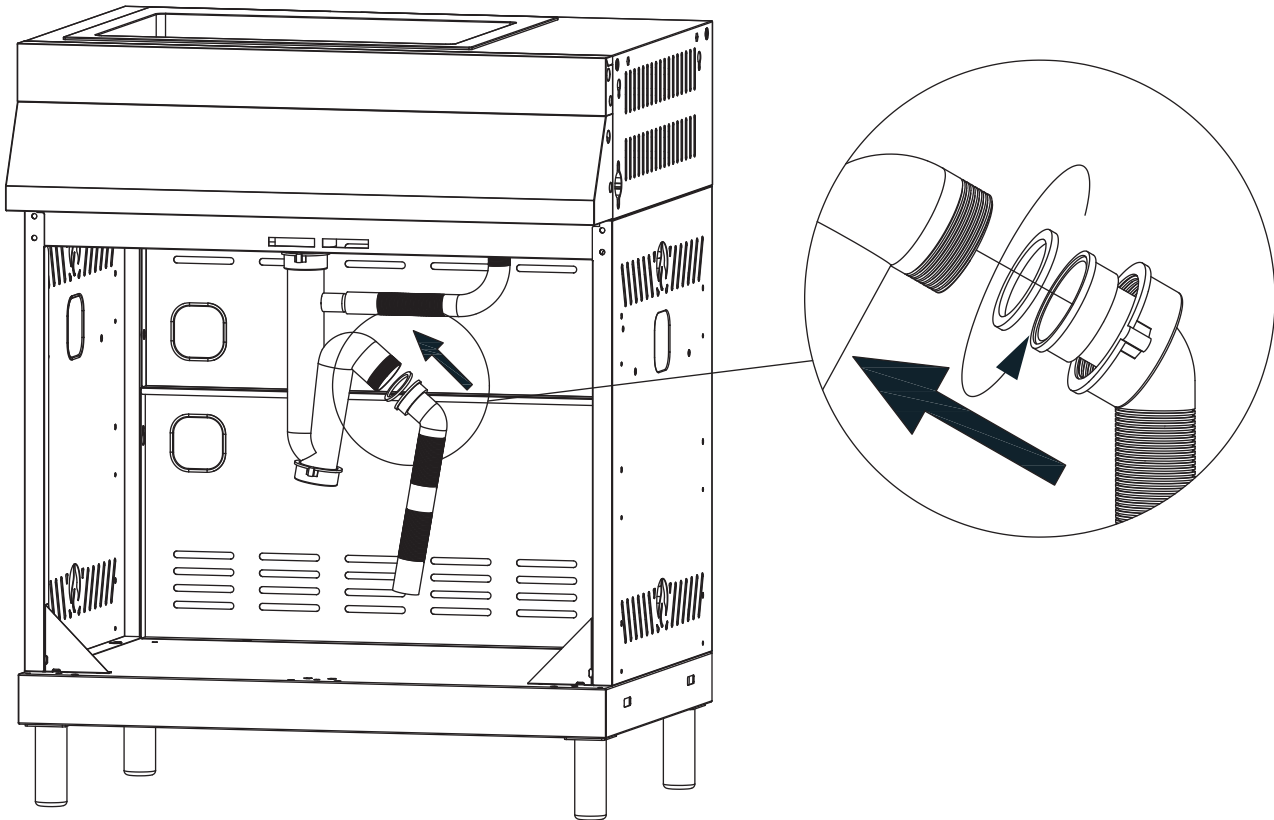

14.

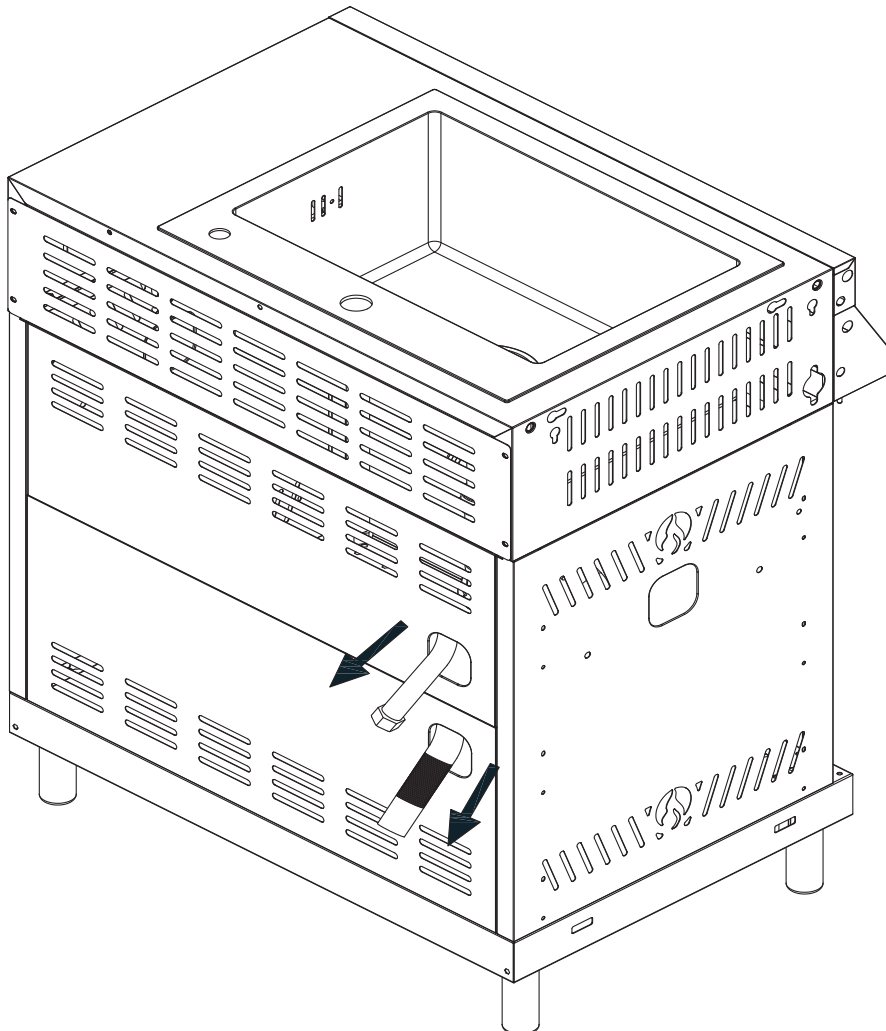

15.



Hinweis: Diese Teile erst nach Verbindung und Höhenanpassung mit weiteren Modulen montieren, siehe ab Seite 16. Die Blende darf nicht bei der Version mit Laufrollen montiert werden.
Note: Please assemble these parts after finishing the connection with other modules and leveling the same height, see from page 16. The bottom decoration can not be mounted on the version with casters.

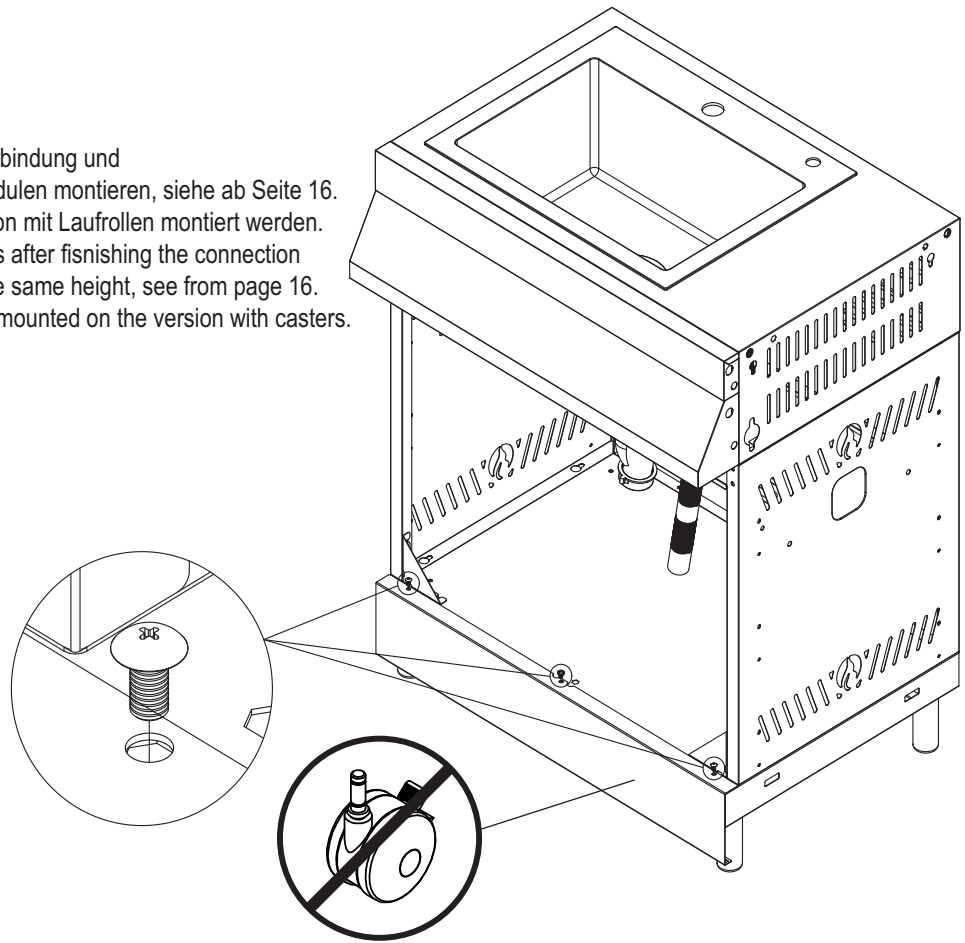

16.



Hinweis: Sollten Sie vorhaben ein weiteres Modul an der rechten Seite zu platzieren, montieren Sie dieses Teil erst nach der Verbindung der beiden Module, siehe ab Seite 16.
Note: If you plan to mount another module on the right side, install this part after connecting the two modules, see from page 16.

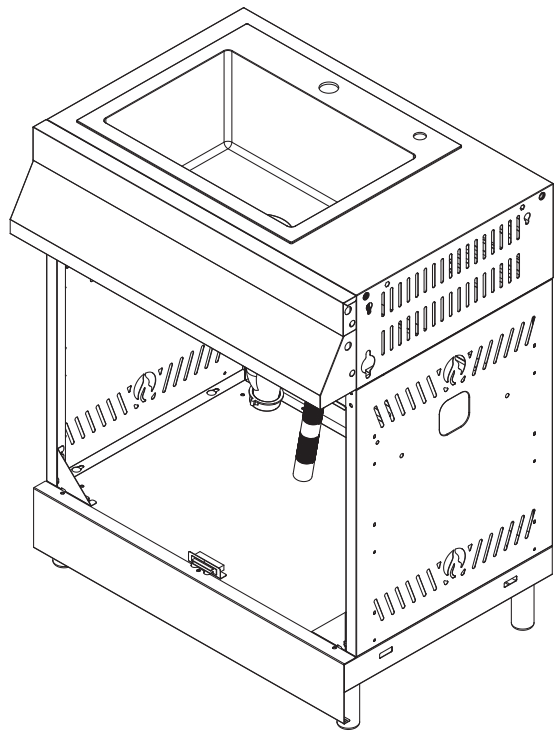
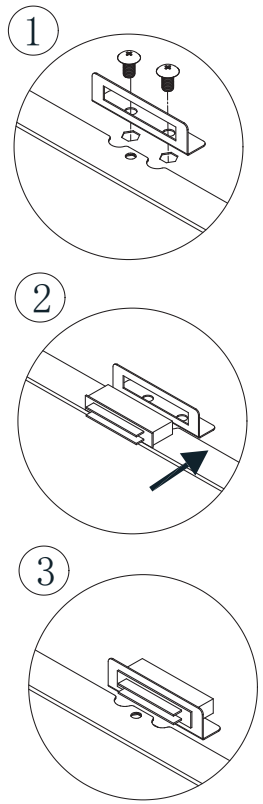

- 17.** **Hinweis:** Dieses Teil erst nach Verbindung und Höhenanpassung mit weiteren Modulen montieren.
Note: Please assemble this part after finishing the connection with other modules and leveling the same height.

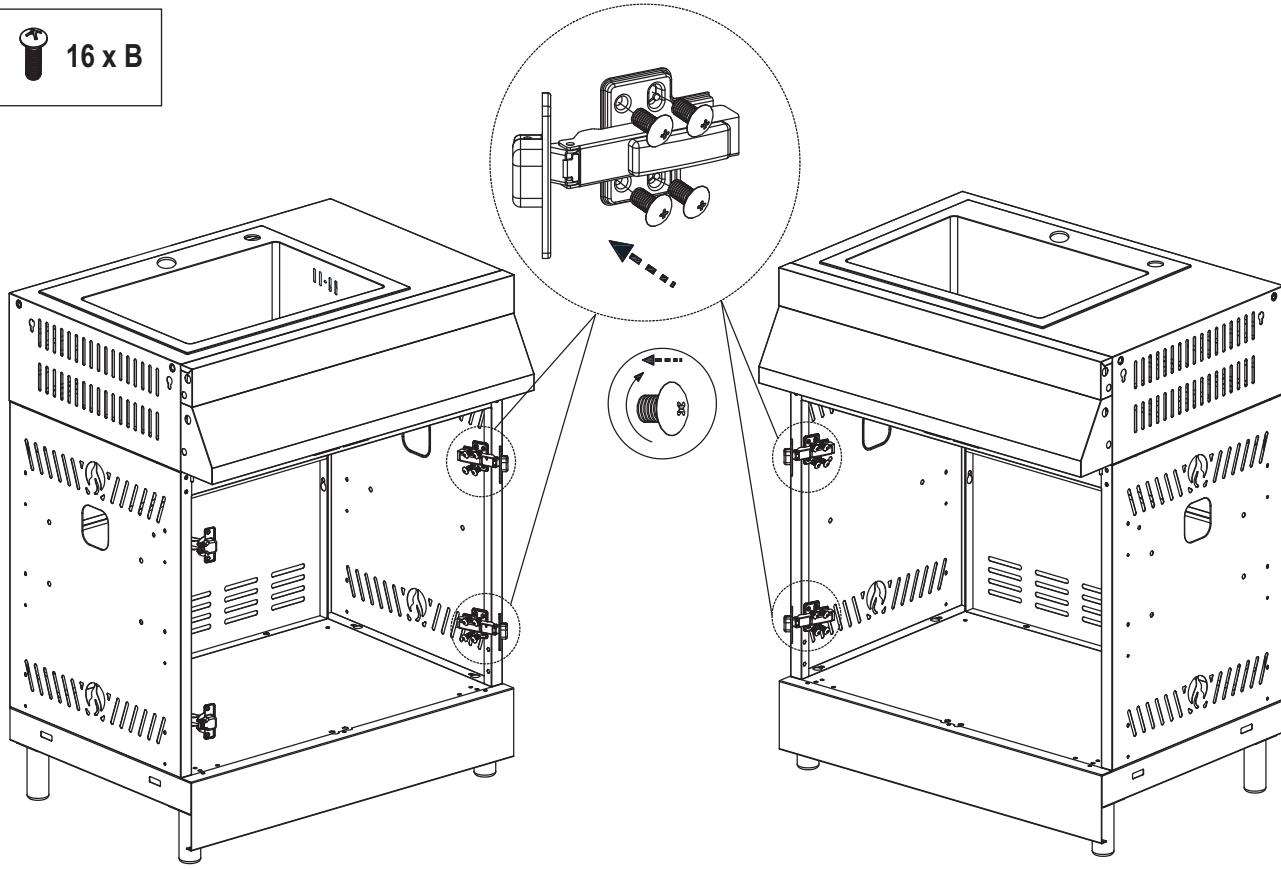

- 18.** **Hinweis:** Dieses Teil erst nach Verbindung und Höhenanpassung mit weiteren Modulen montieren.
Note: Please assemble this part after finishing the connection with other modules and leveling the same height.

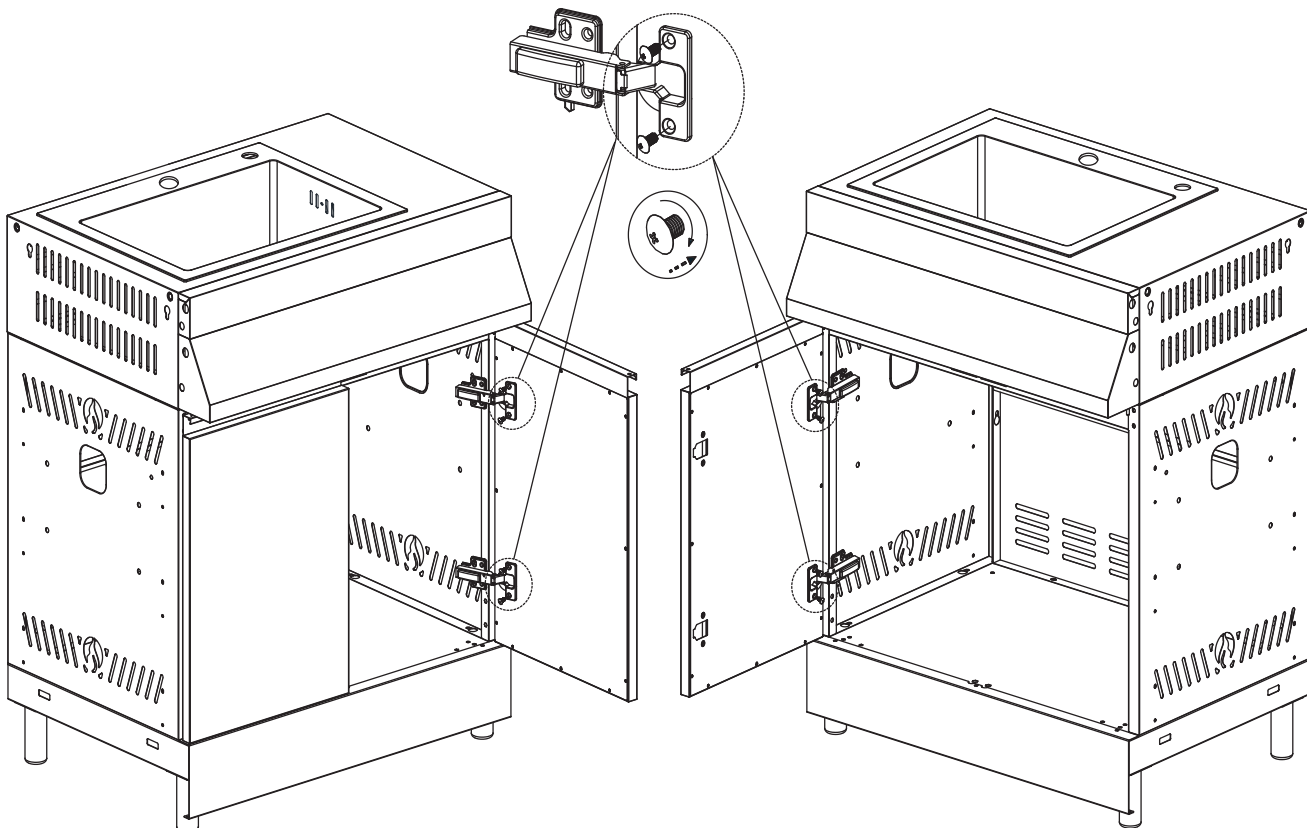

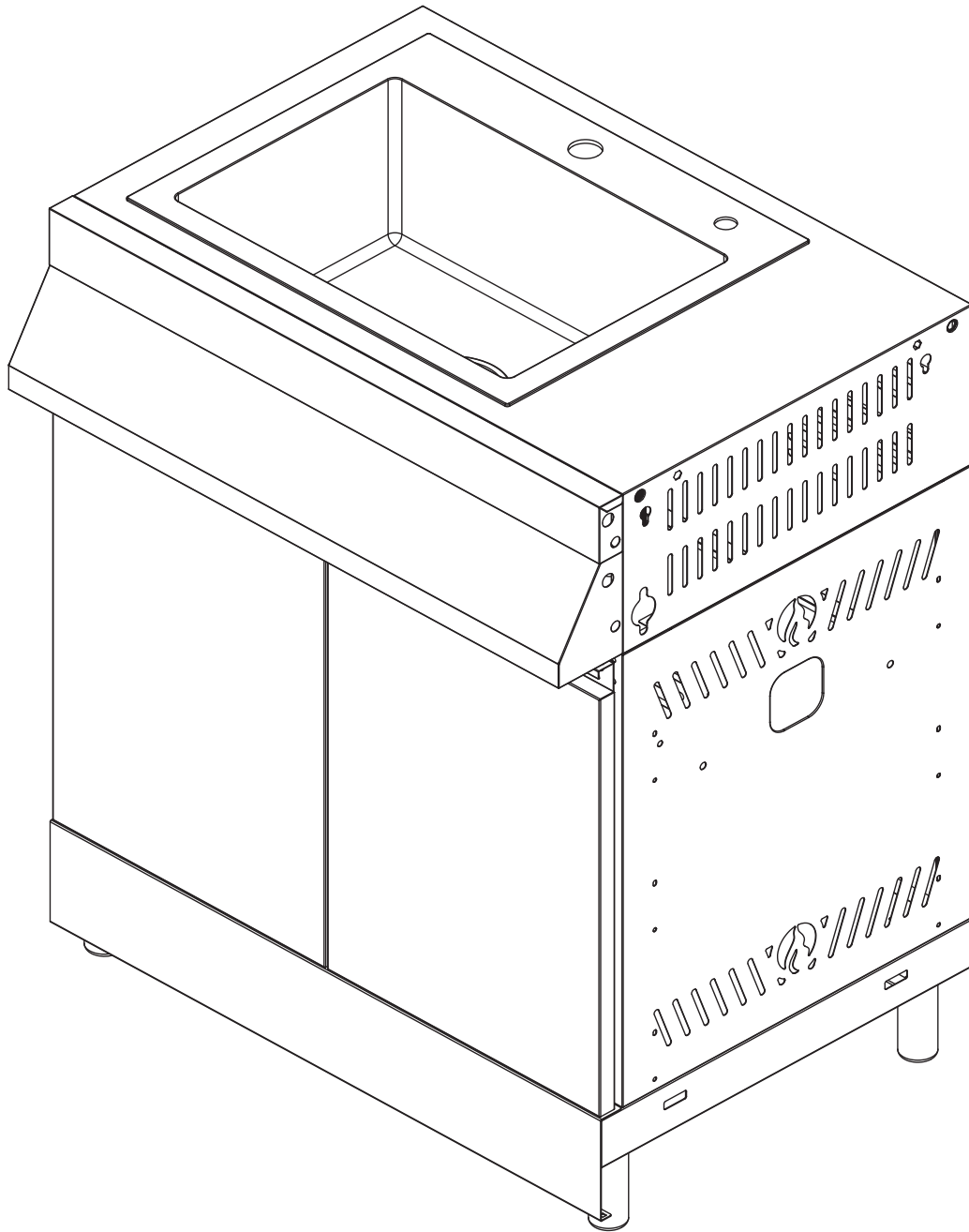



Spare parts

No.	Appellation	Art.-No.	No.	Appellation	Art.-No.
1	Sink	9080050	11	Door Hinge	9080038
2	Sink Countertop Rear Seal Plate	9080051	12	Decorative Frame of Bottom Panel	9083014
3	Sink Countertop Assembly	9080052	13	Right Door	9080036
4	Top Rear Panel of the Body	9080053	14	Left Door	9080037
5	Rear Panel of the Body	9080054	15	Body Front Beam	9080013
6	Right Side Panel of the Body	9080009	16	Body Left Side Panel	9080008
7	Sink Body Bottom Plate	9085306	17	Sewer Assembly	9080055
8	Triangle Bracket	9920032	18	Sink Fixing Tab	9080056
9	Brake Wheel	9200044	19	Door Suction Seat	9080032
10	Foot Support	9080011	20	Door Magnet	9200031

Verbinden von Modulen zur Outdoor-Grillküche Connecting modules to an outdoor barbecue kitchen

1.

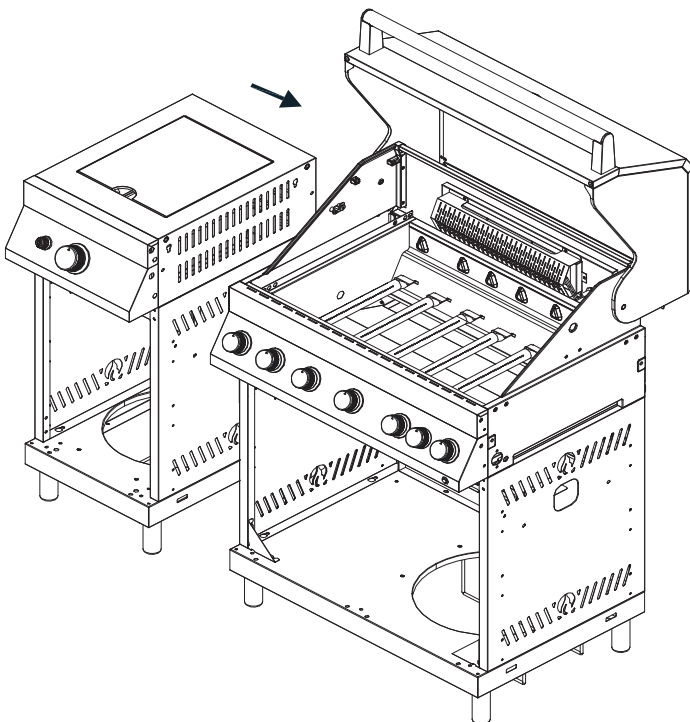

2a. Hinweis: Bei der Verwendung von Grillrosten aus Edelstahl montieren Sie das linke Abschirmblech bitte wie abgebildet.
Notice: Please mount the left insulation plate as shown when using the stainless steel grids.

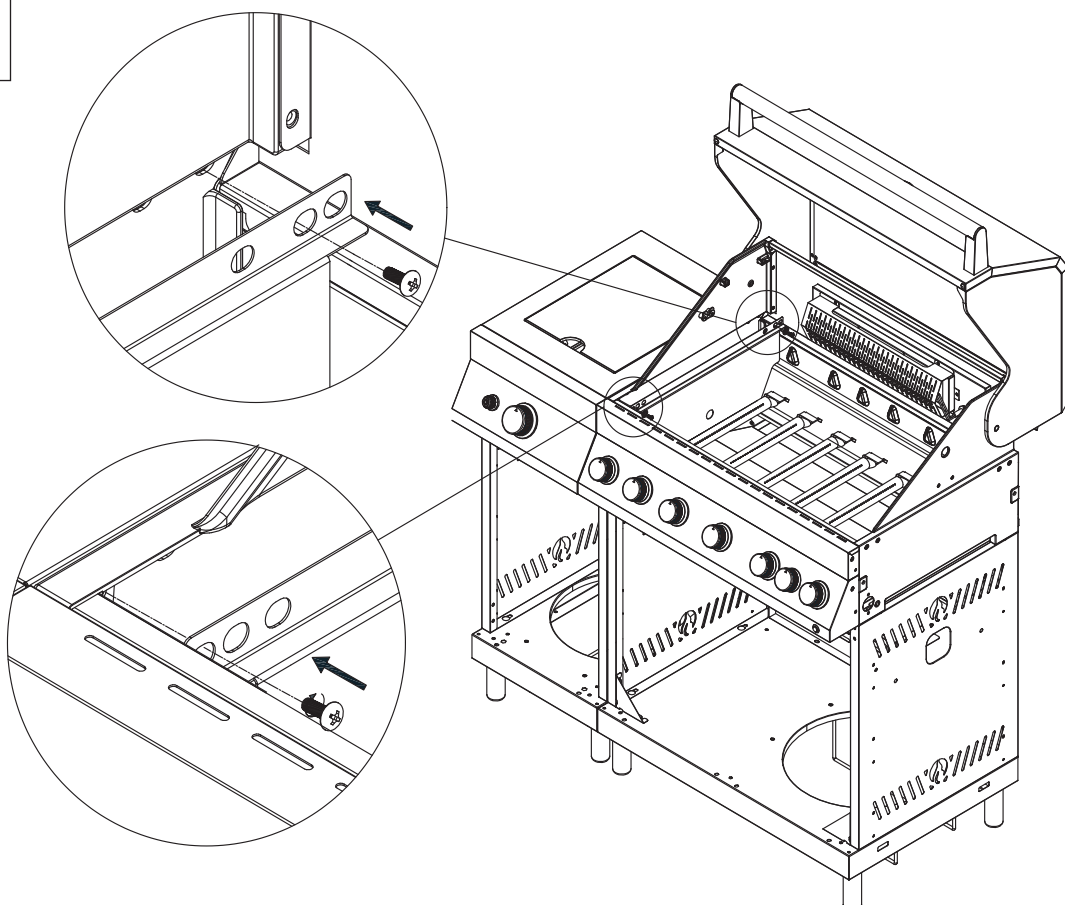

2b. Hinweis: Bei der Verwendung von Grillrosten aus Gusseisen montieren Sie das linke Abschirmblech bitte wie abgebildet.
 Notice: Please mount the left insulation plate as shown when using the cast iron grids.

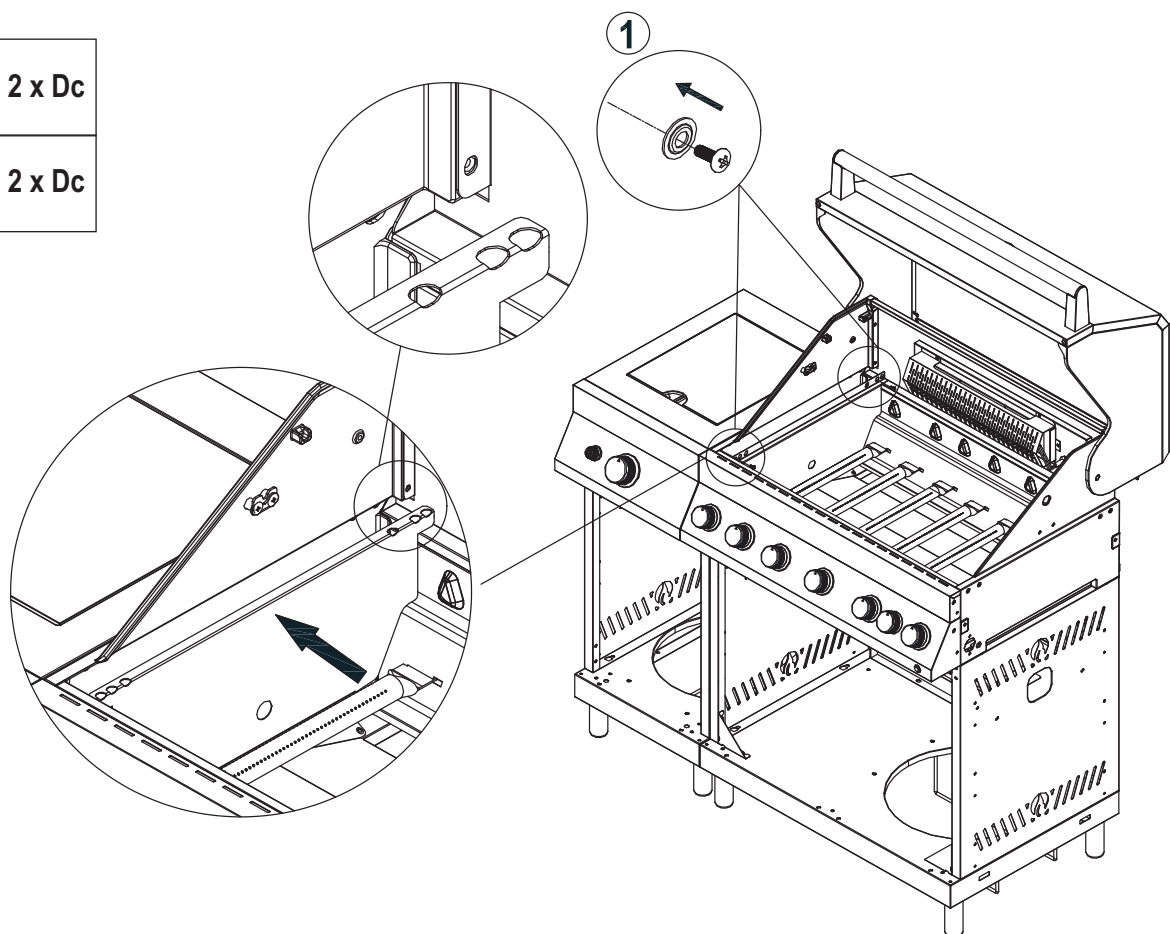
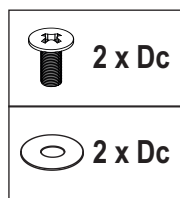

3.

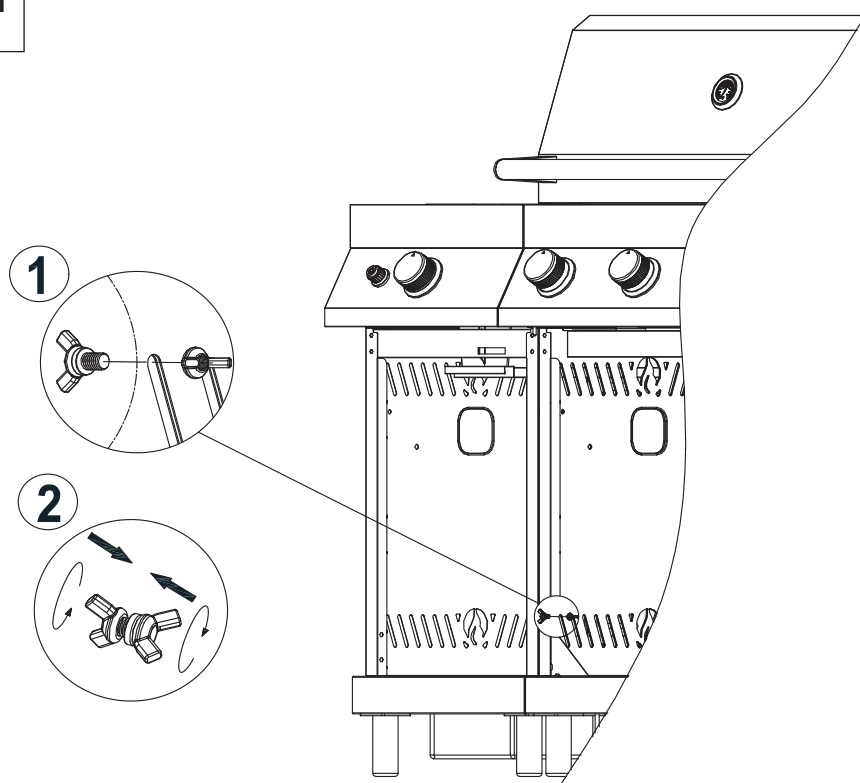
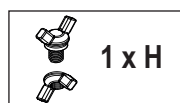

4.

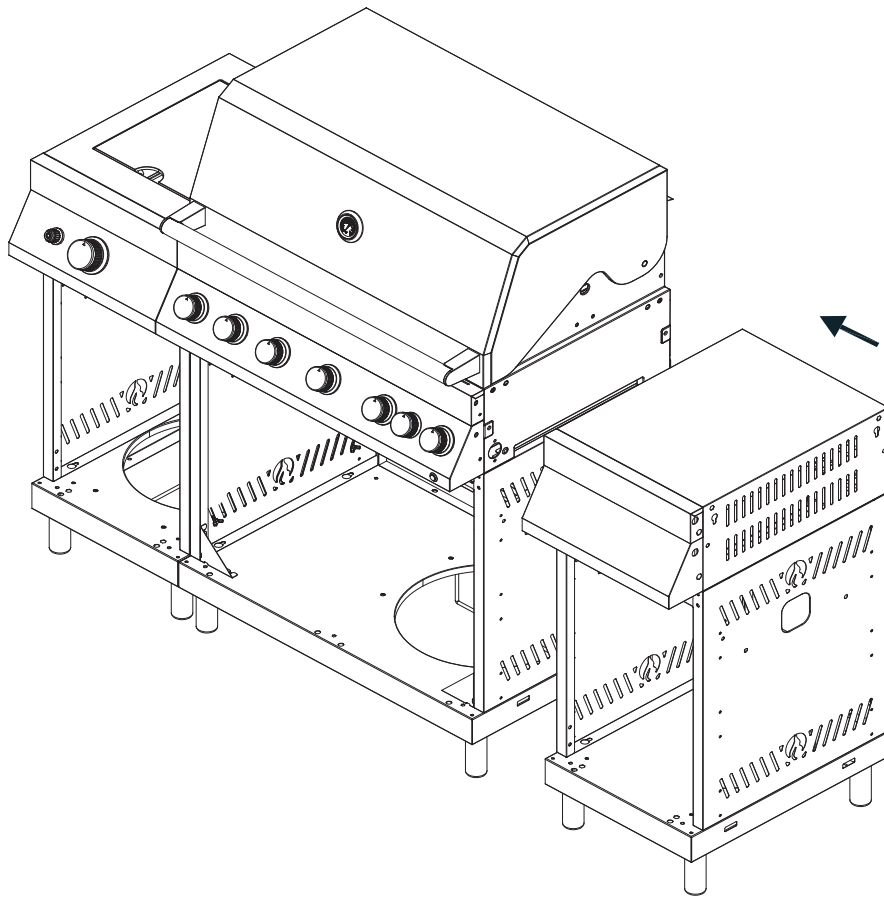

5a. Hinweis: Bei der Verwendung von Grillrosten aus Edelstahl montieren Sie das rechte Abschirmblech bitte wie abgebildet.
 Notice: Please mount the right insulation plate as shown when using the stainless steel grids.

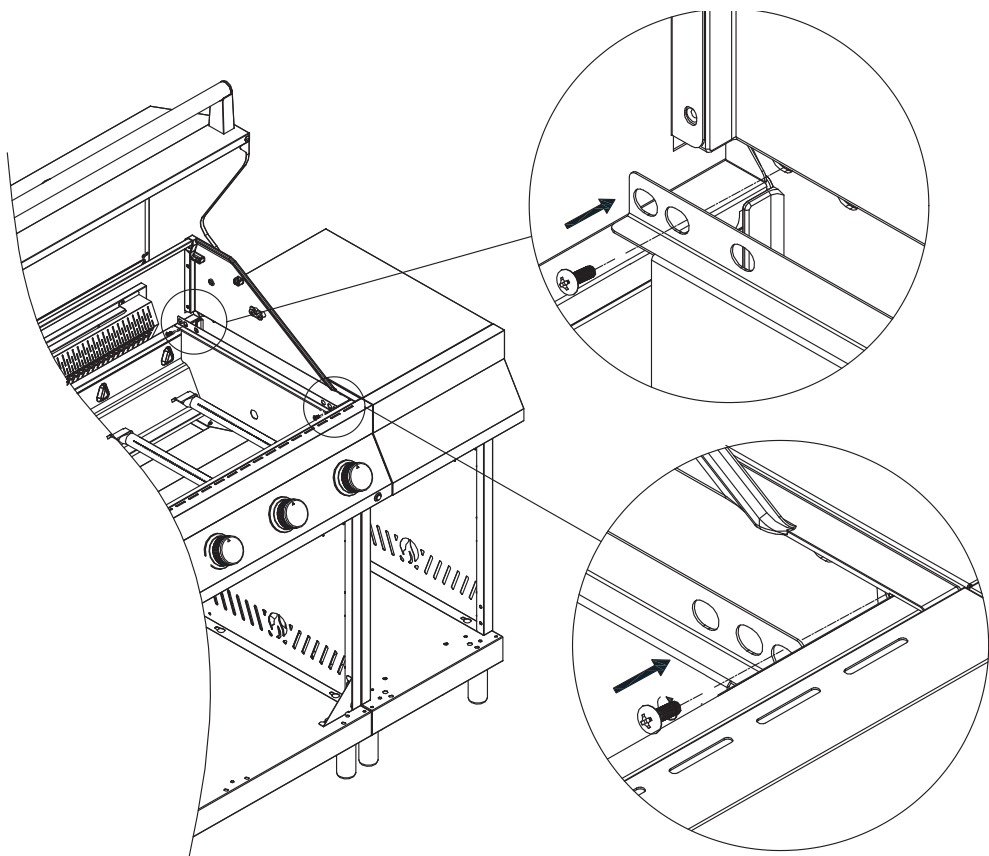

5b. Hinweis: Bei der Verwendung von Grillrosten aus Gusseisen montieren Sie das rechte Abschirmblech bitte wie abgebildet.
 Notice: Please mount the right insulation plate as shown when using the cast iron grids.

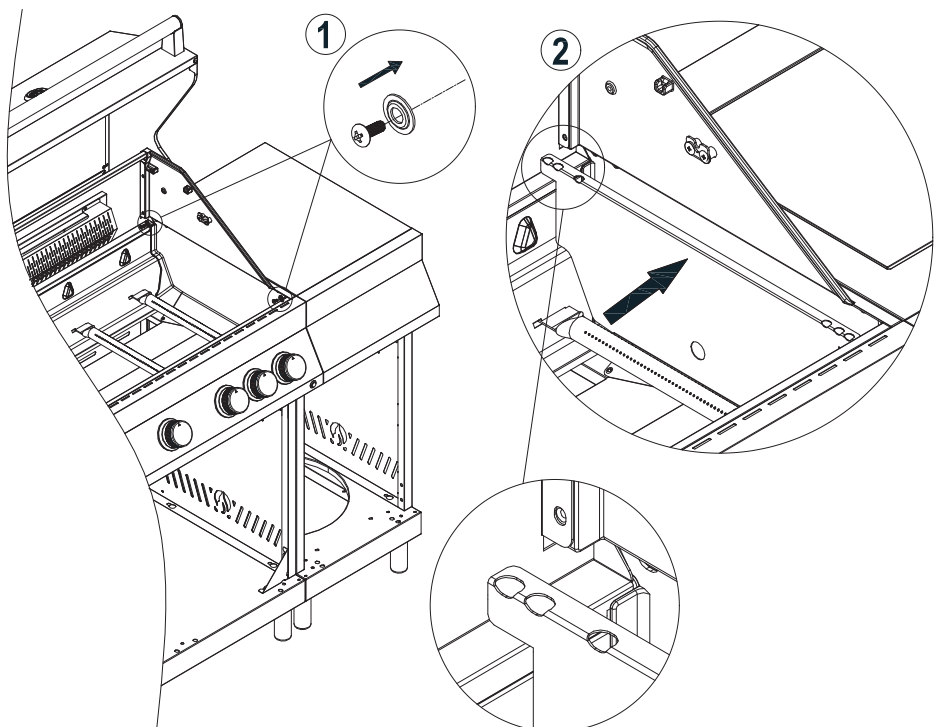
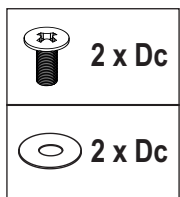

6.

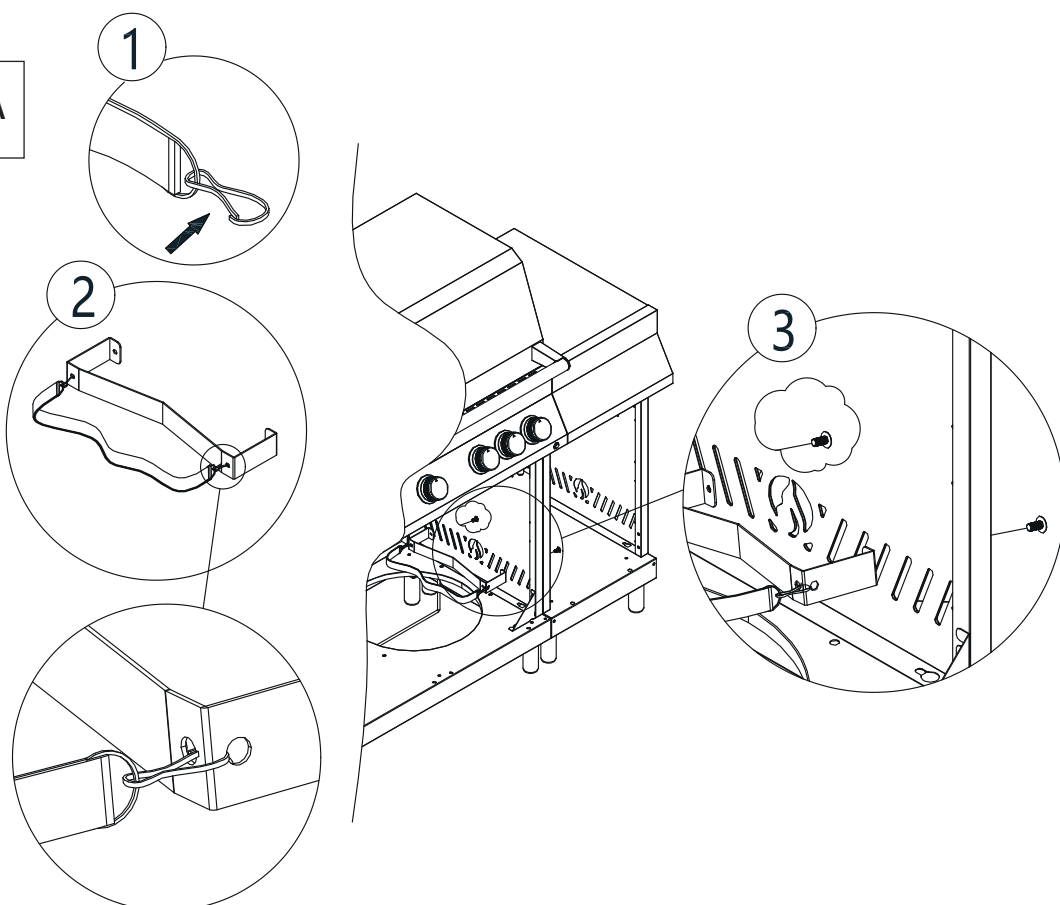
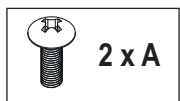

7.

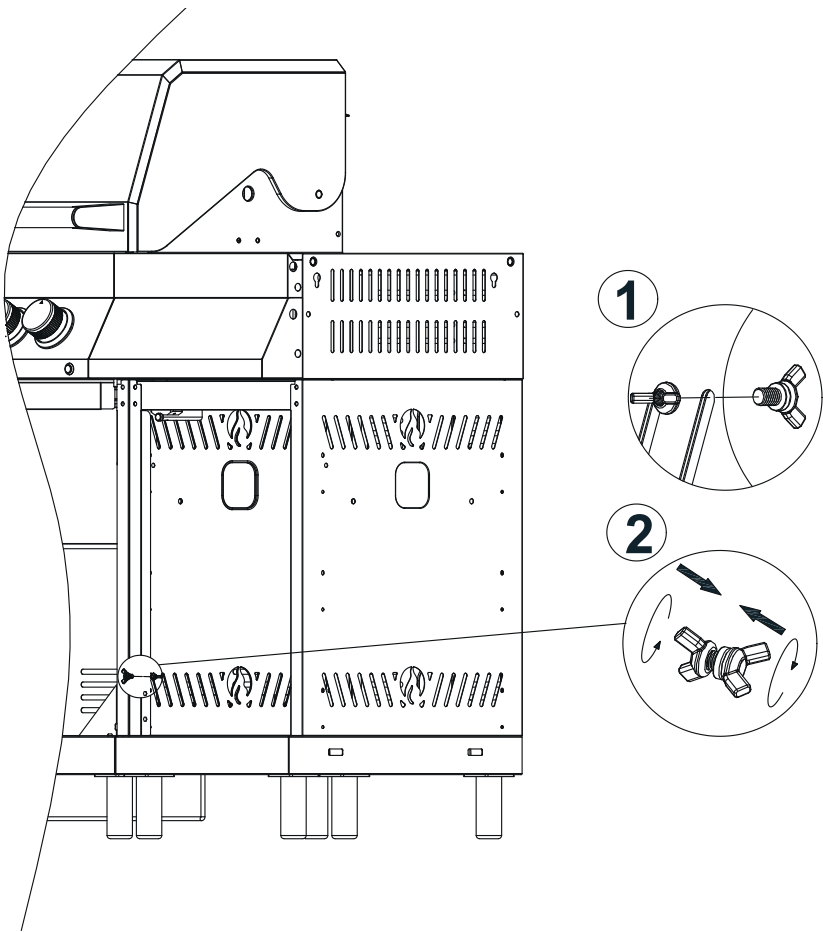

8.

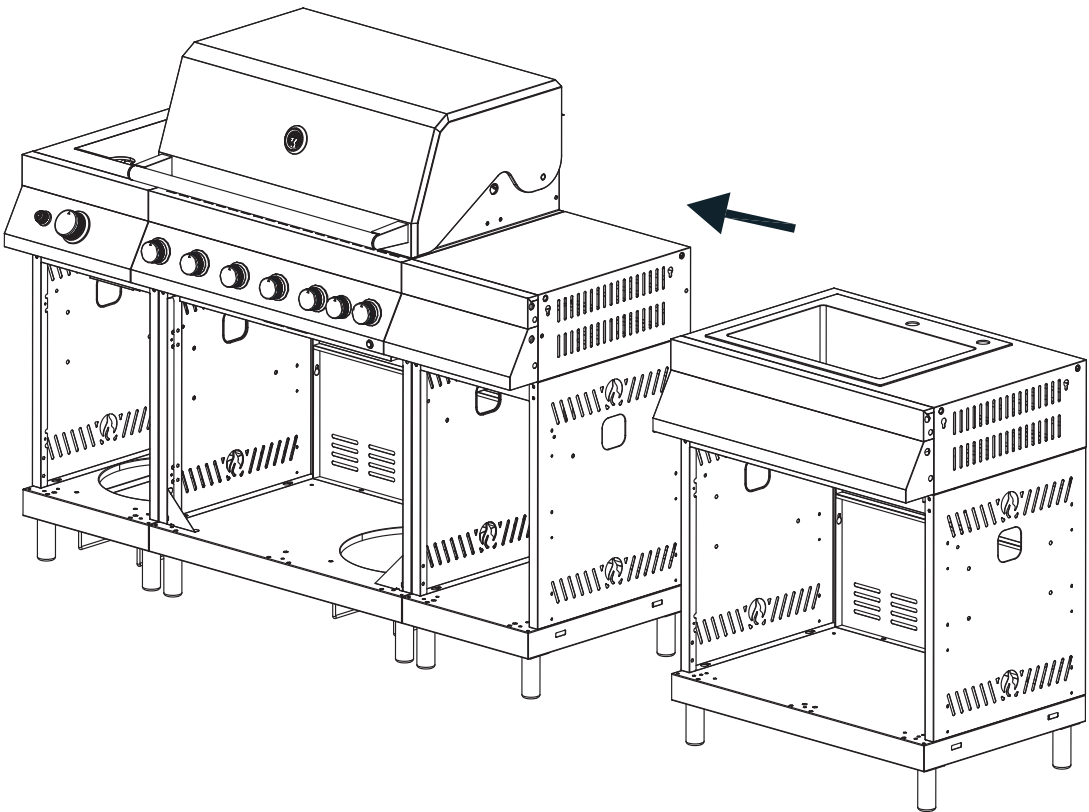

9.

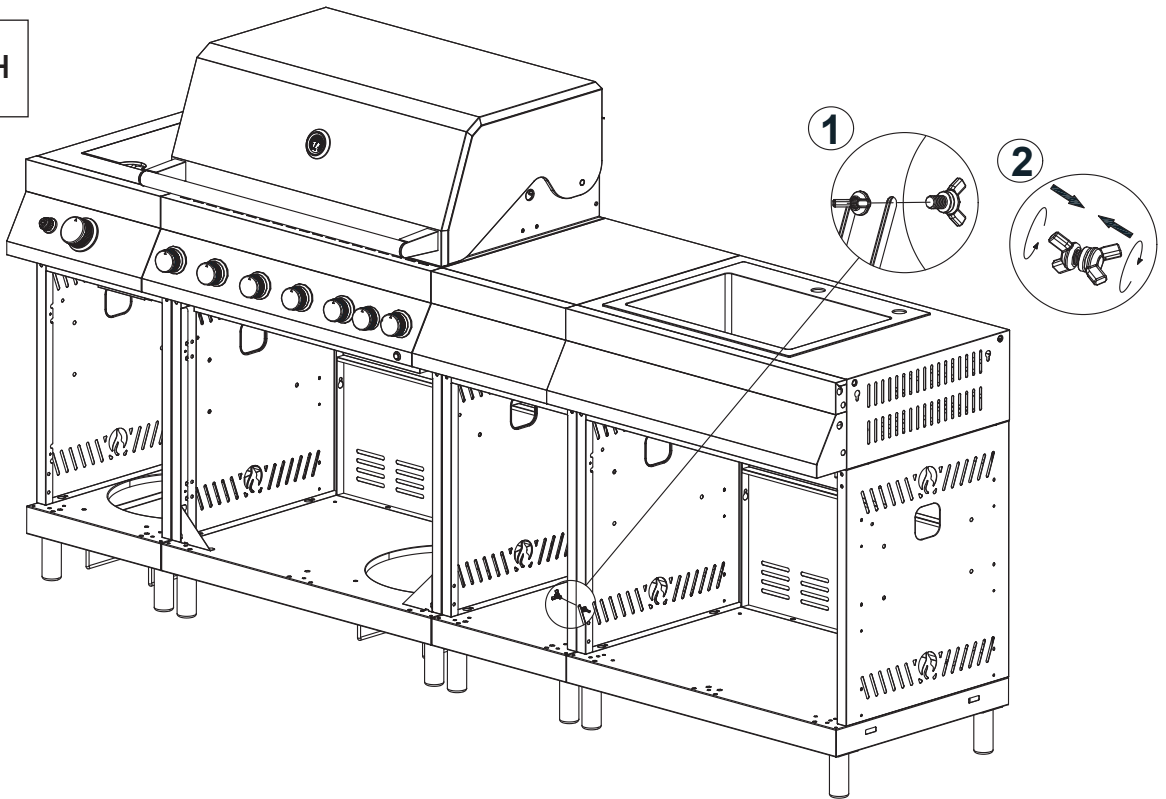

10.

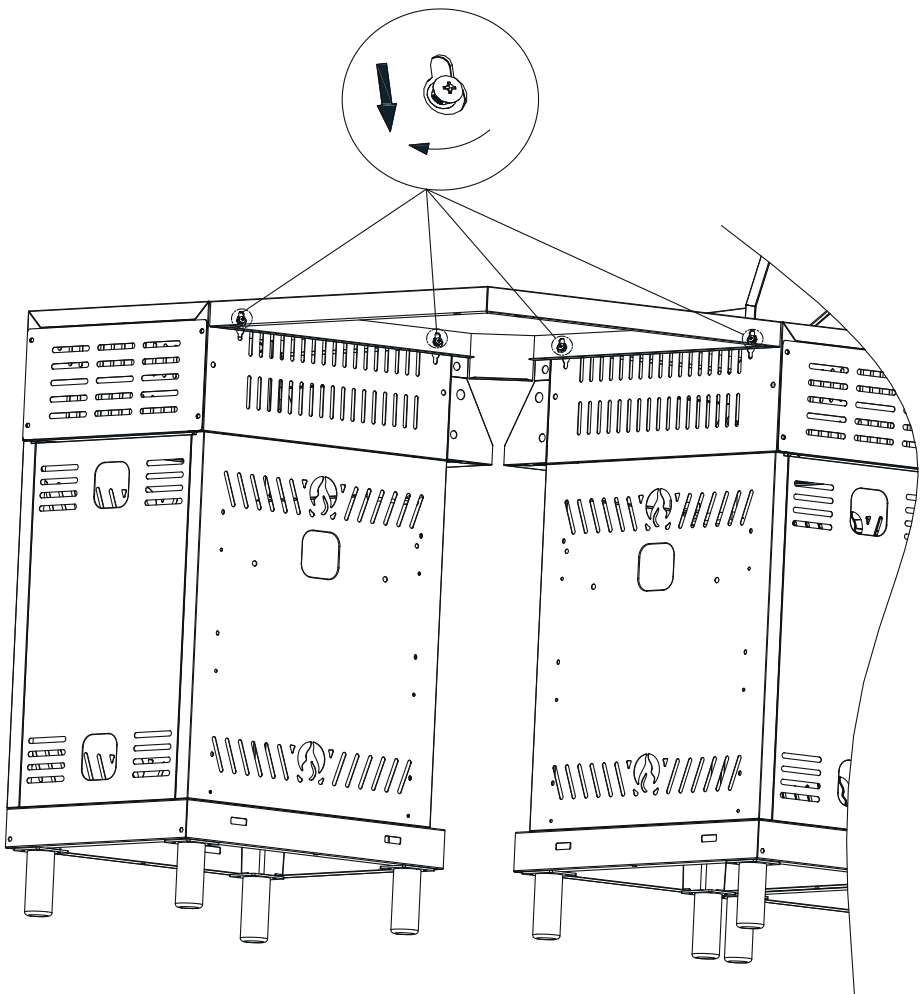
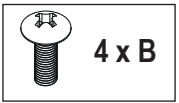

11.

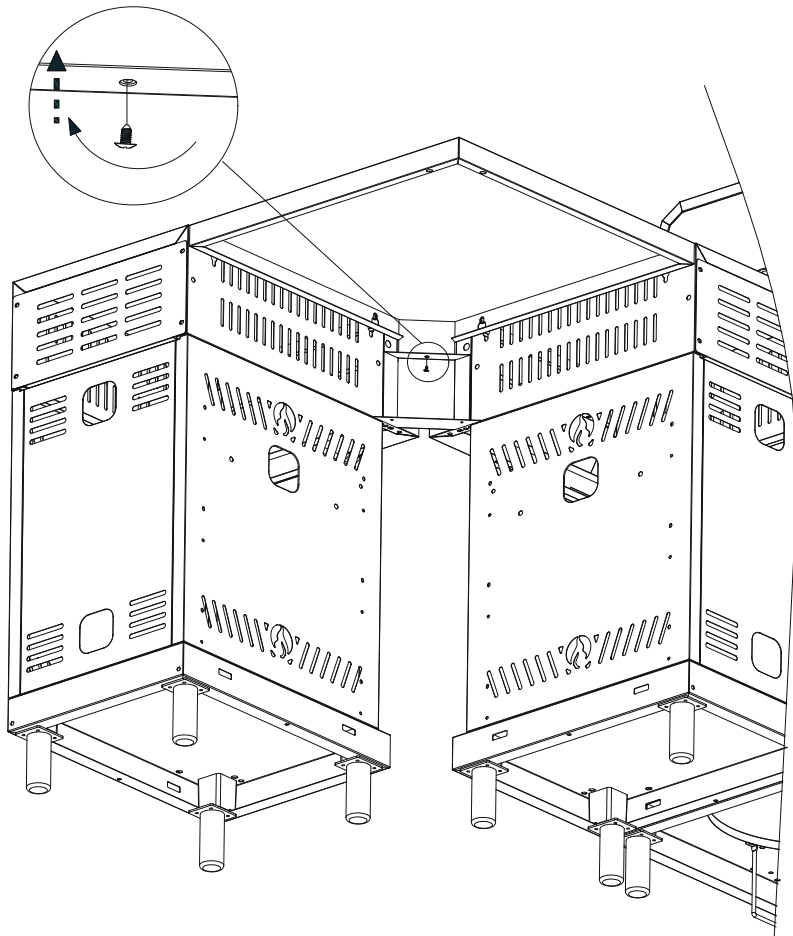

12.

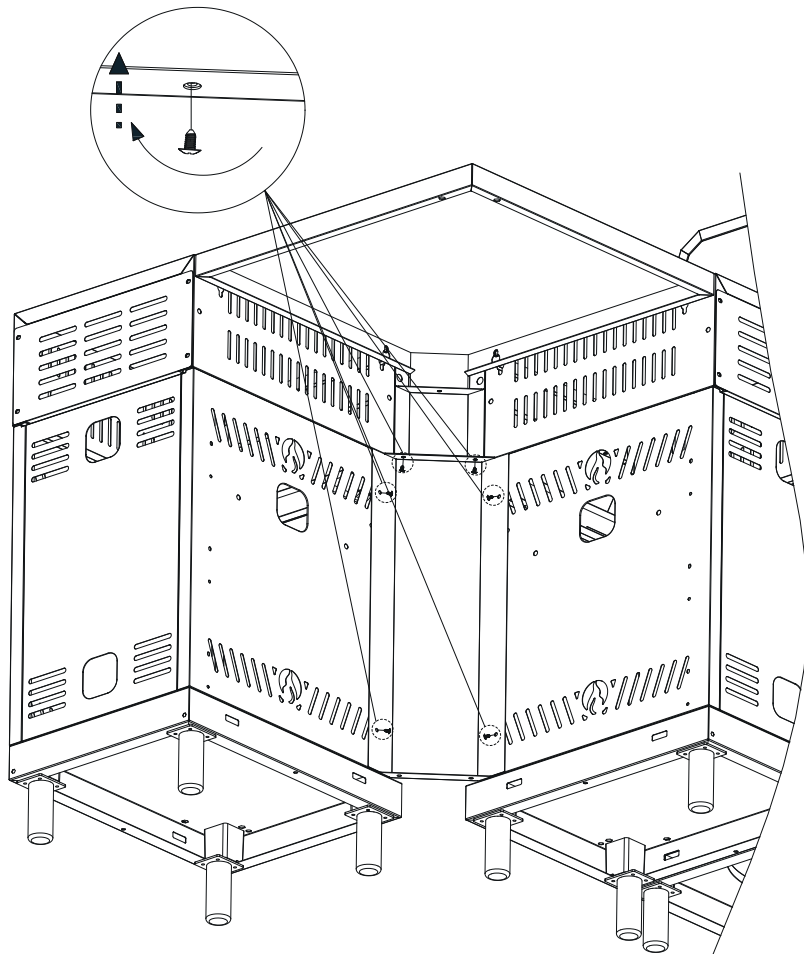
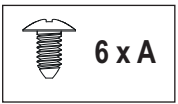

13.

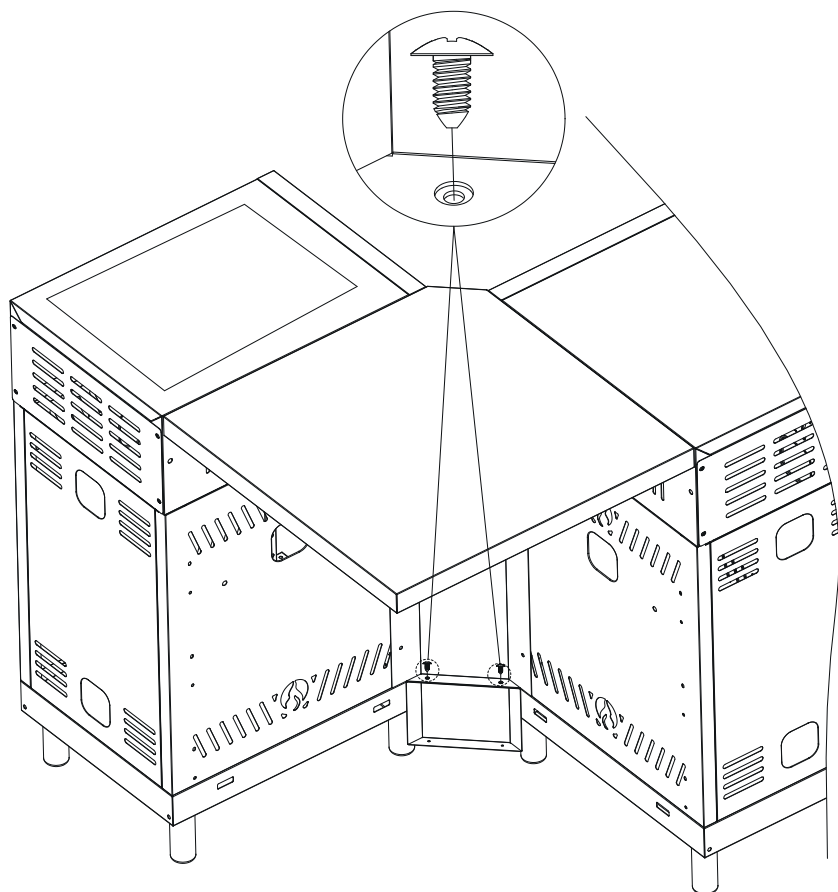

14.

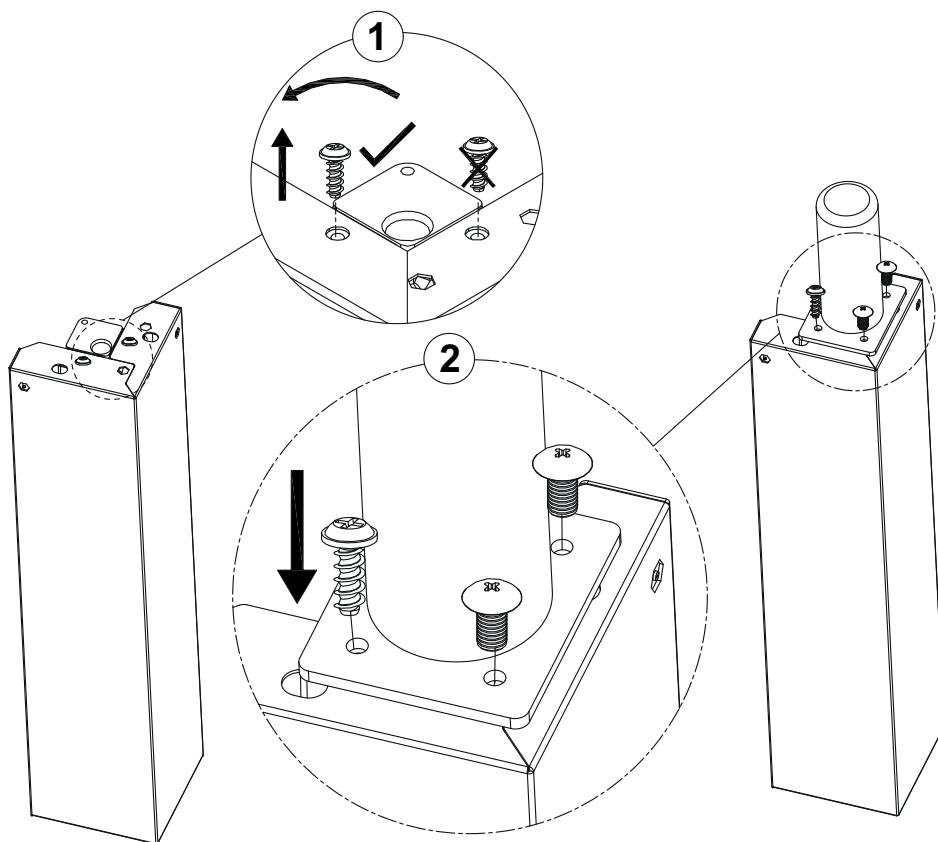

15.

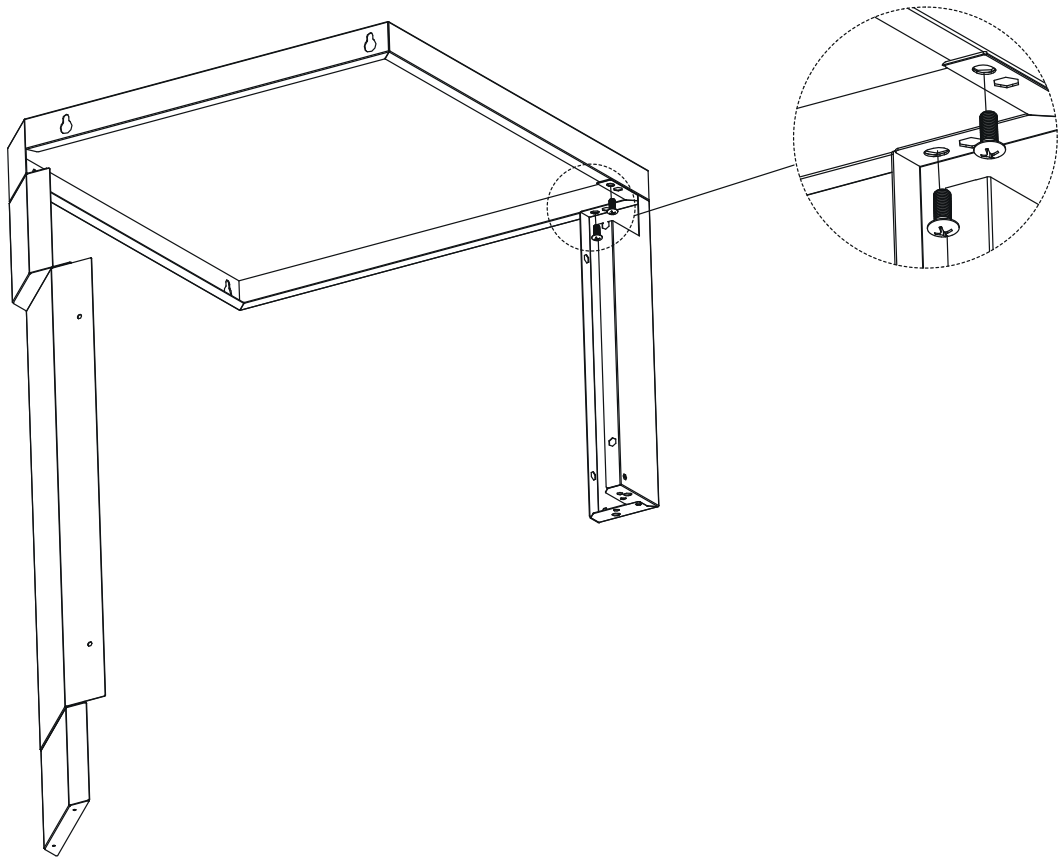
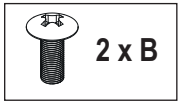

16.

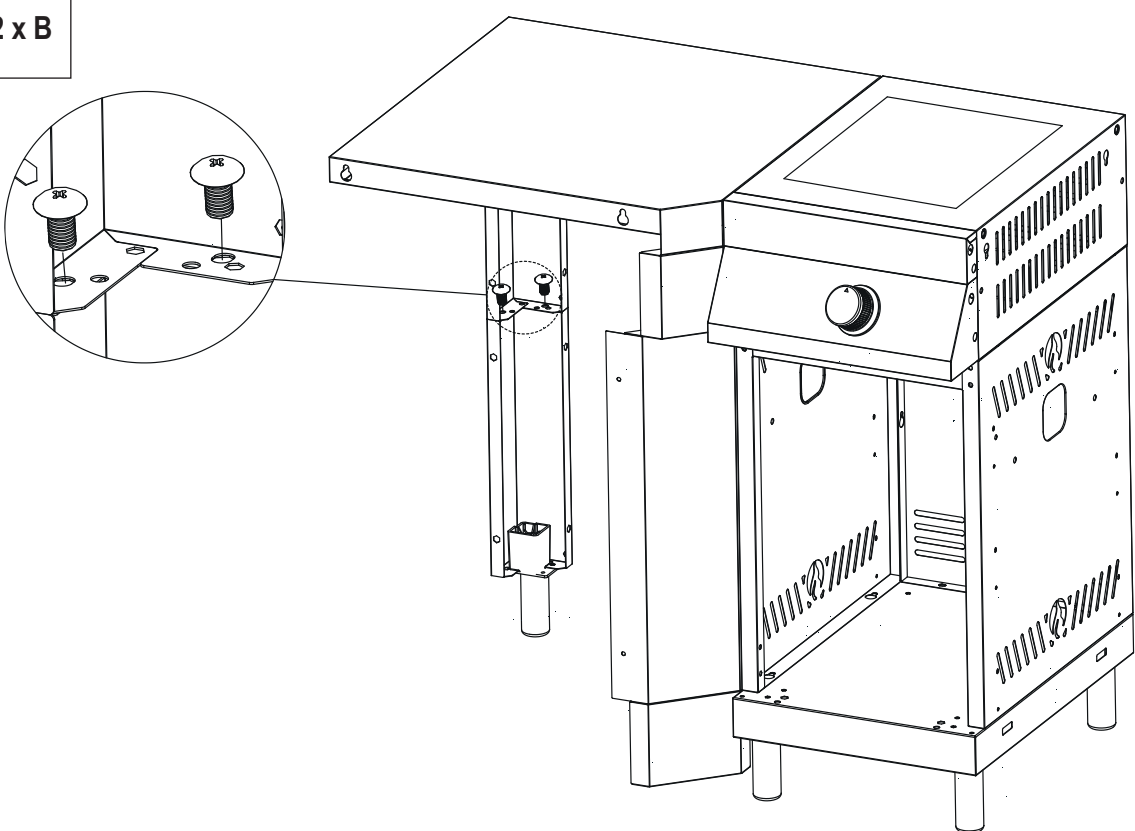
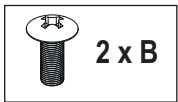

17.

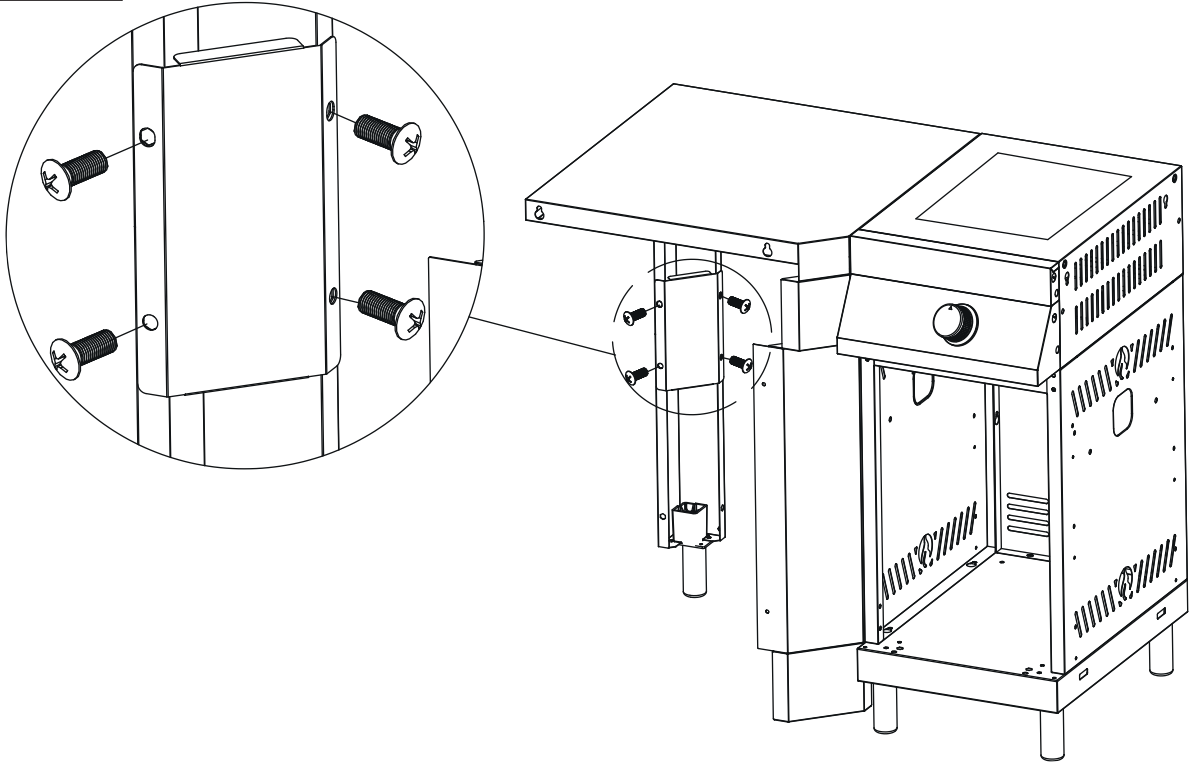

18.

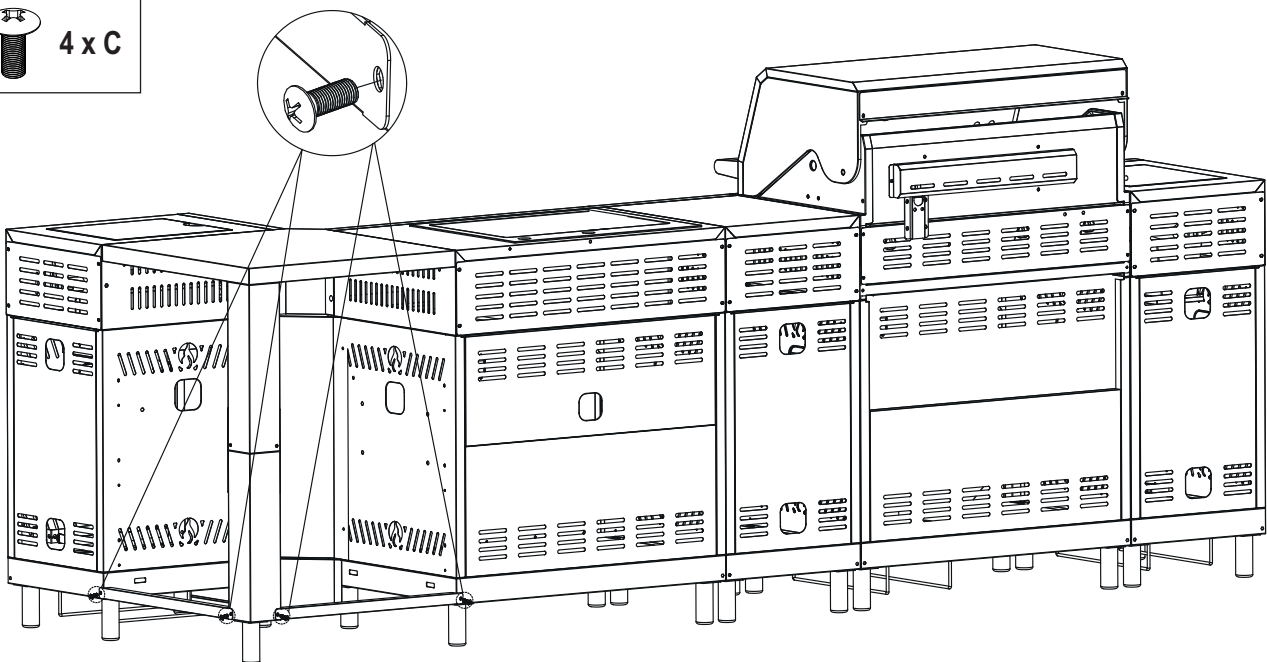
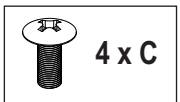

19.

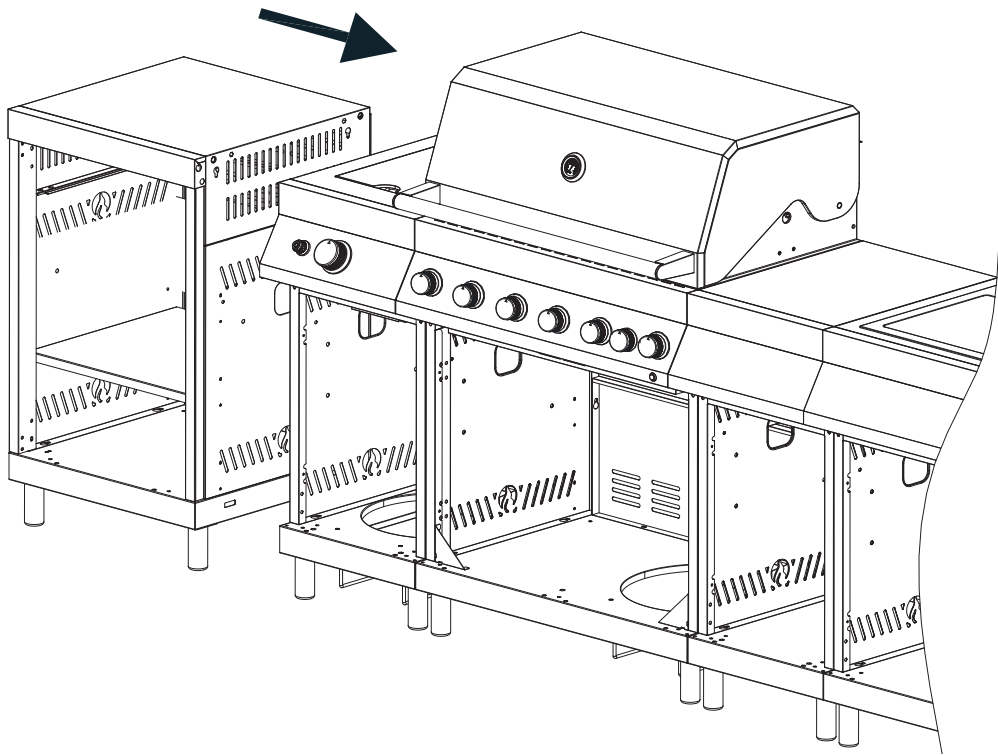

20.

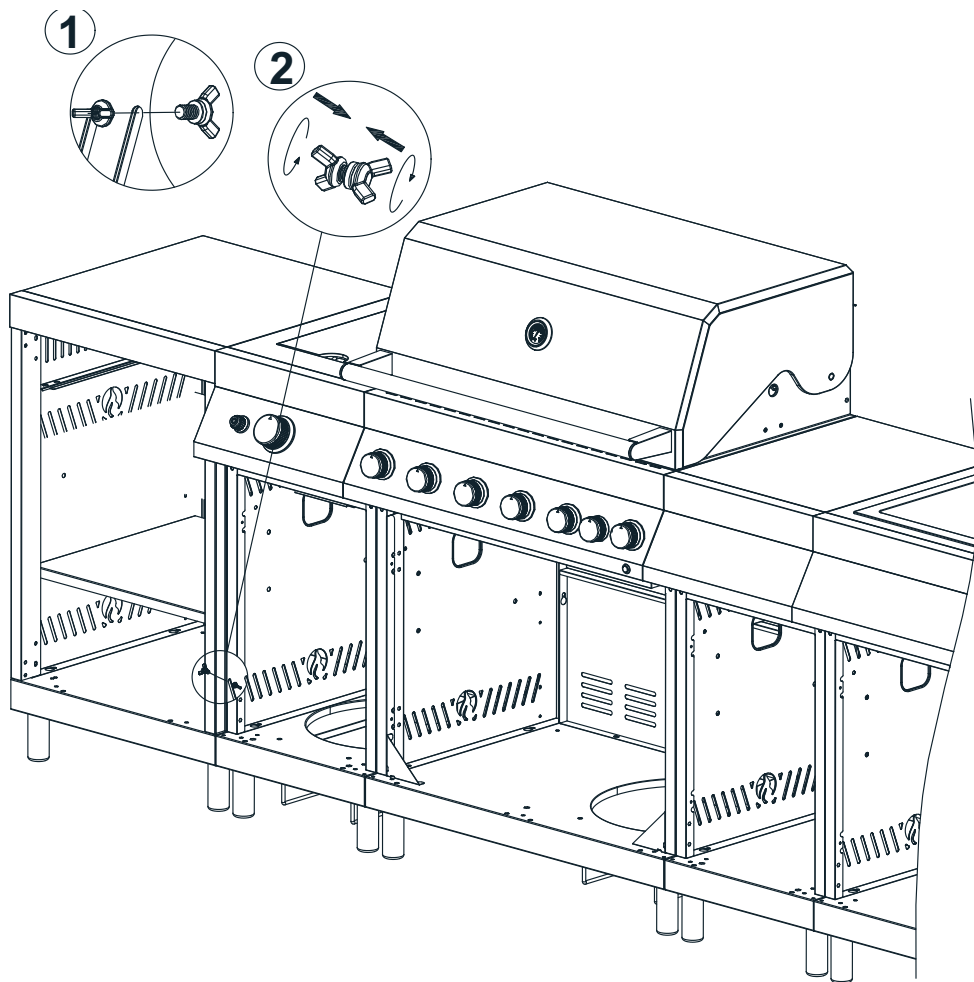

21.

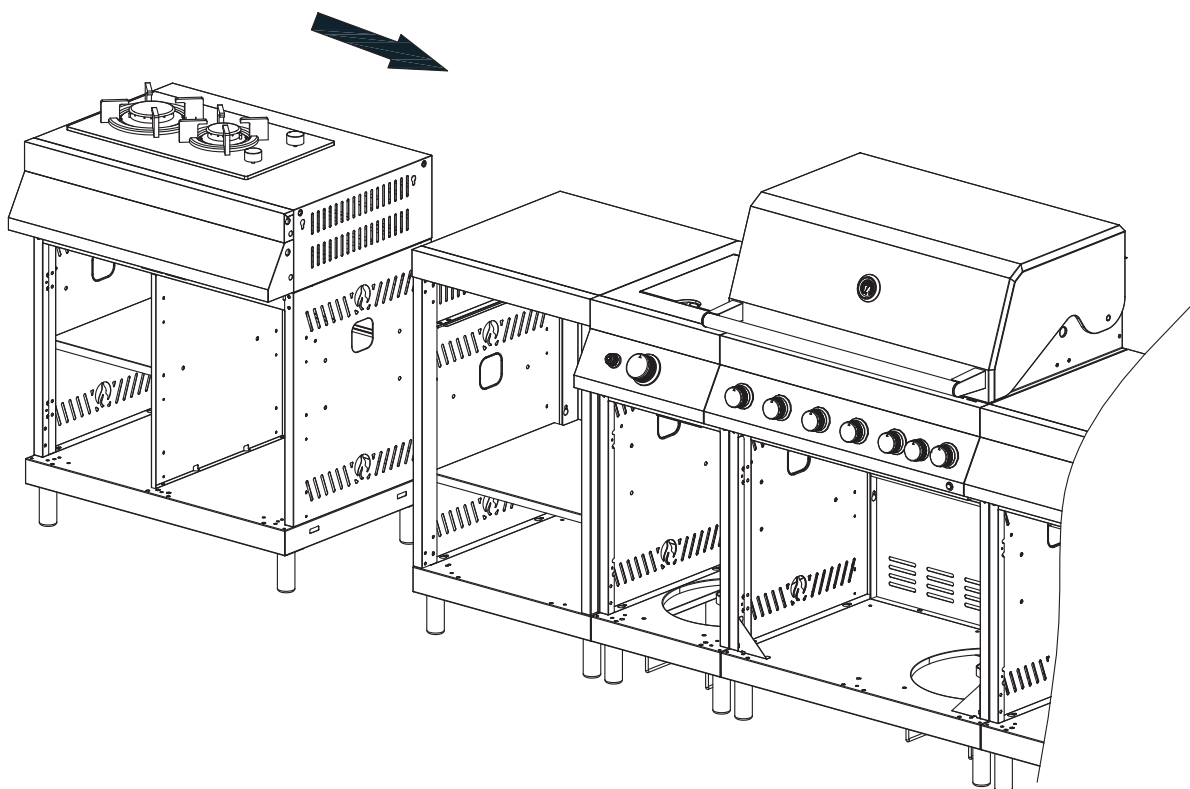

22.

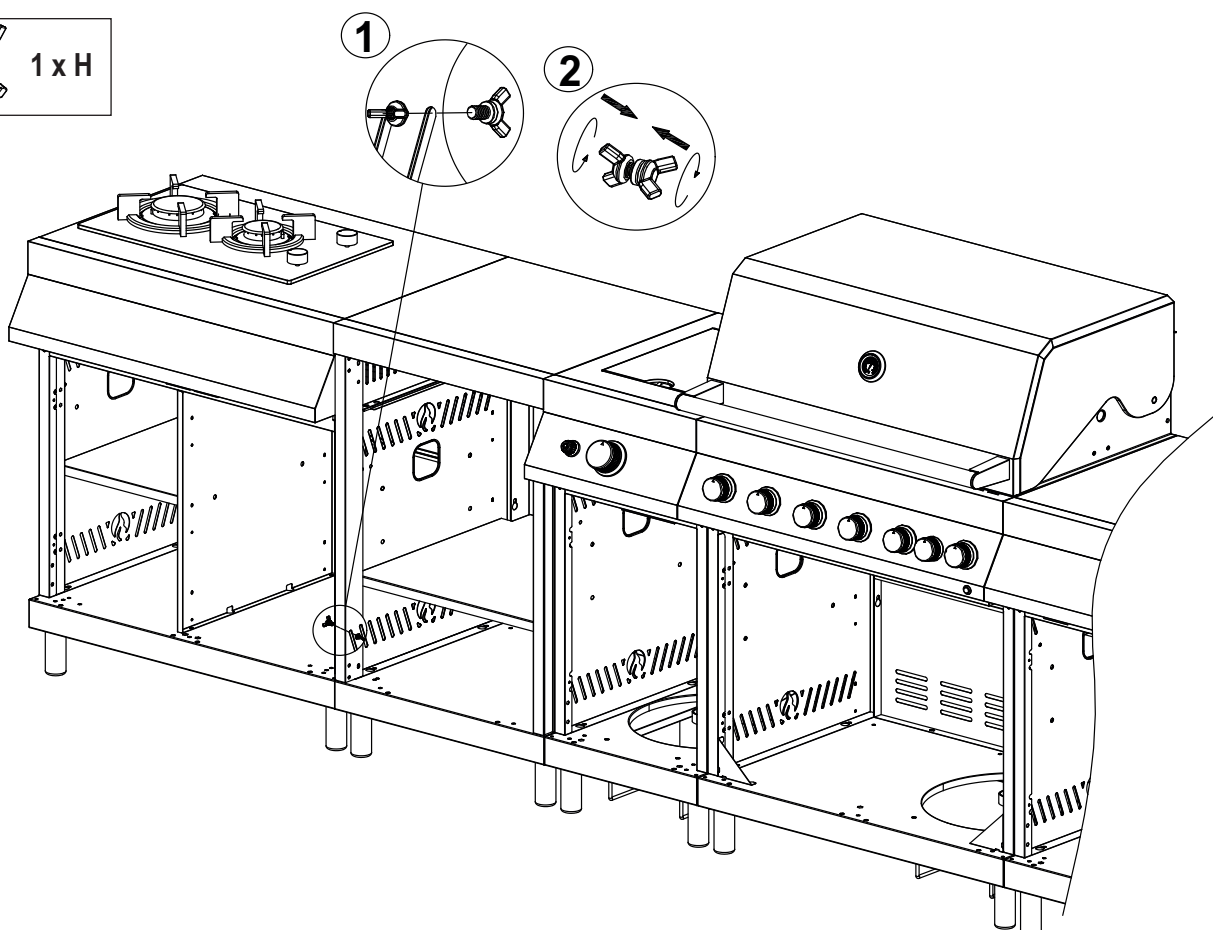
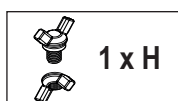

23.

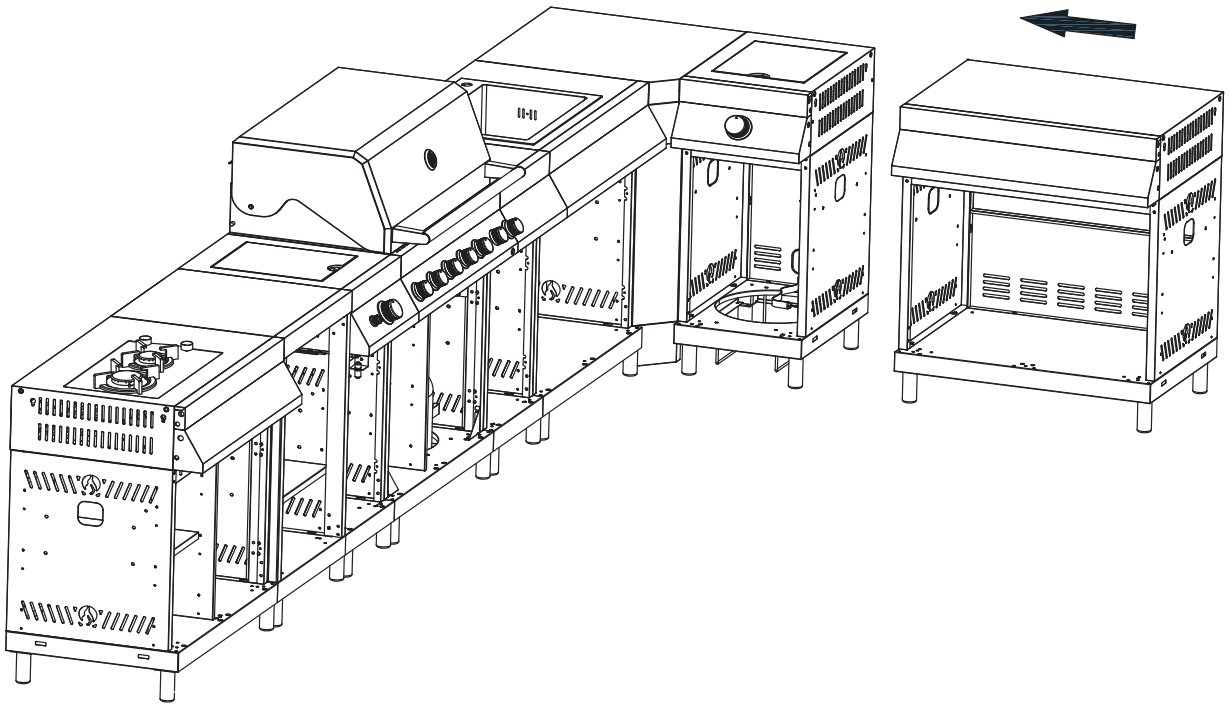

24.

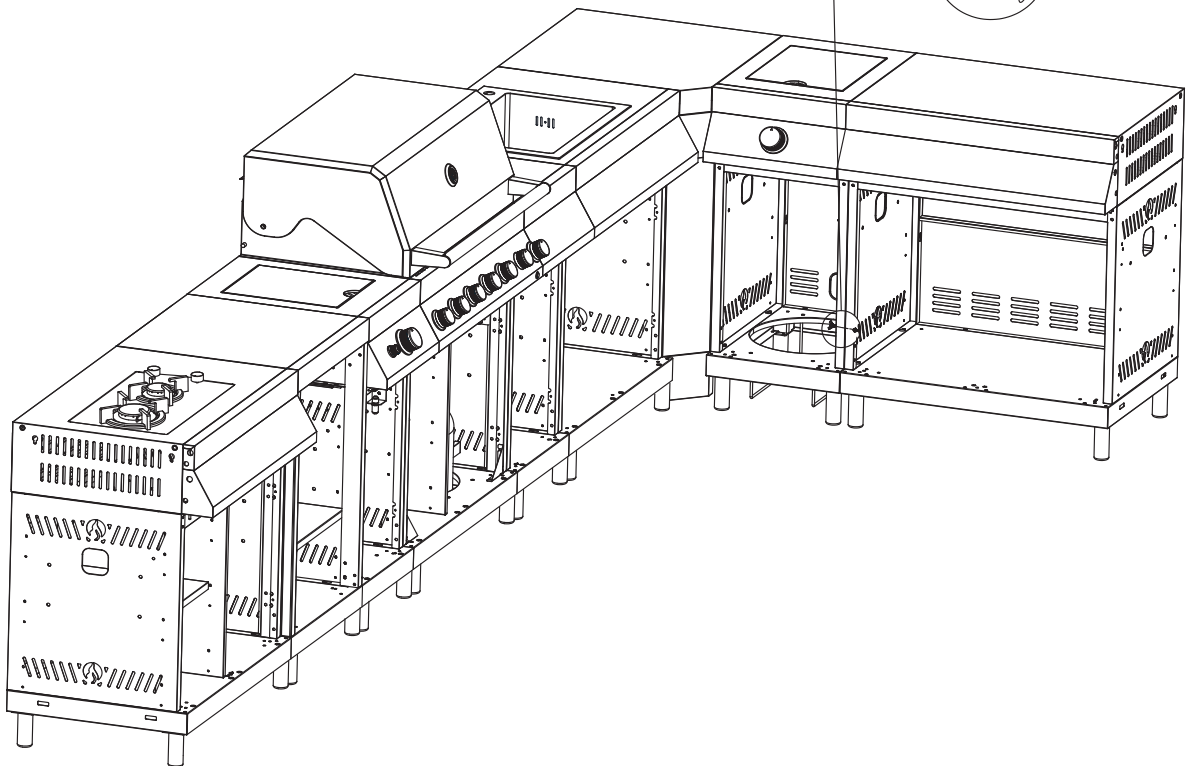
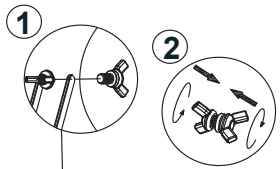

25.

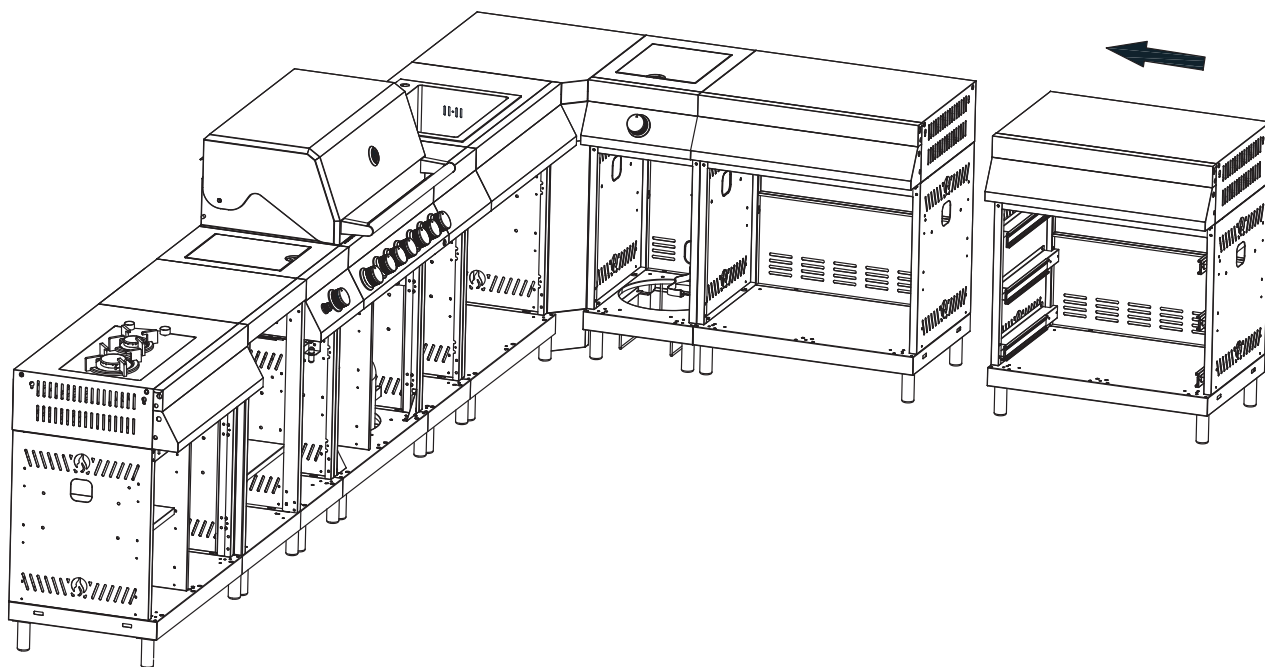

26.

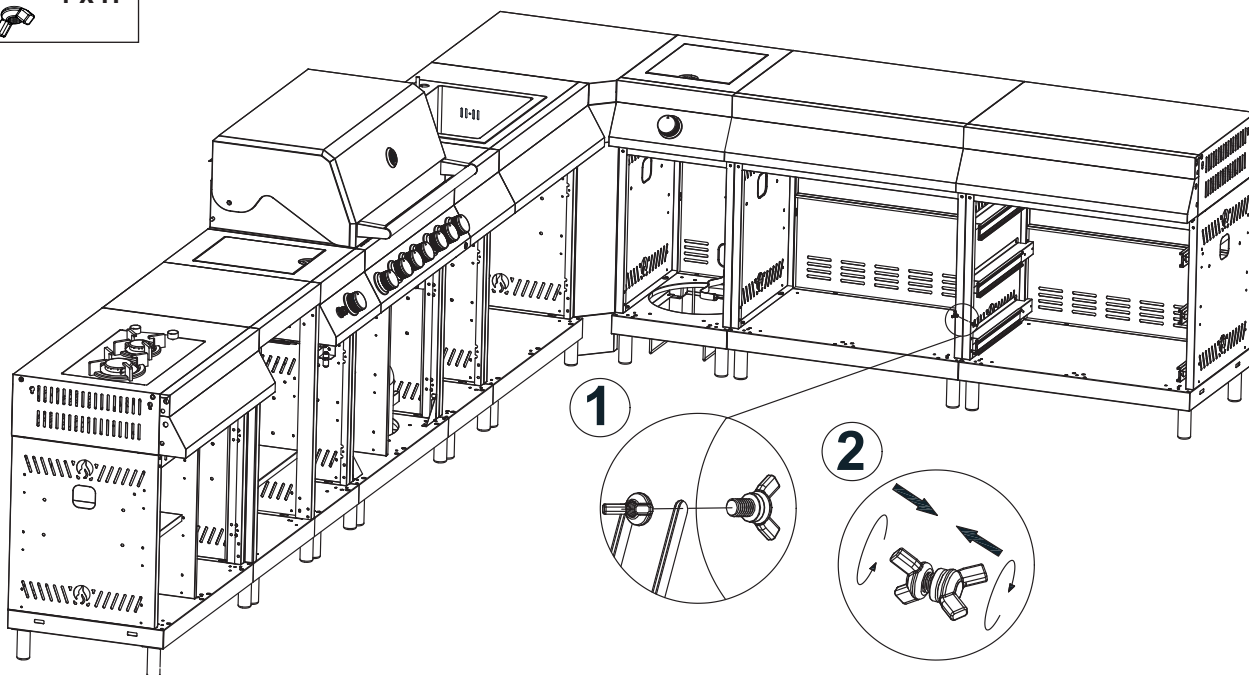
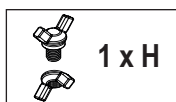

27.

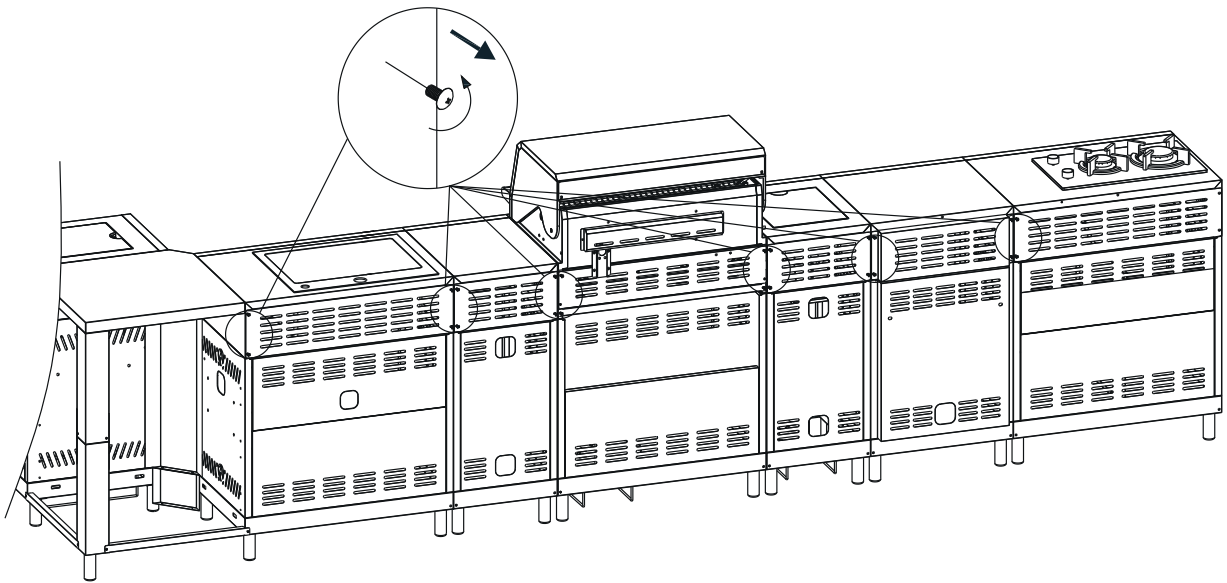

28.

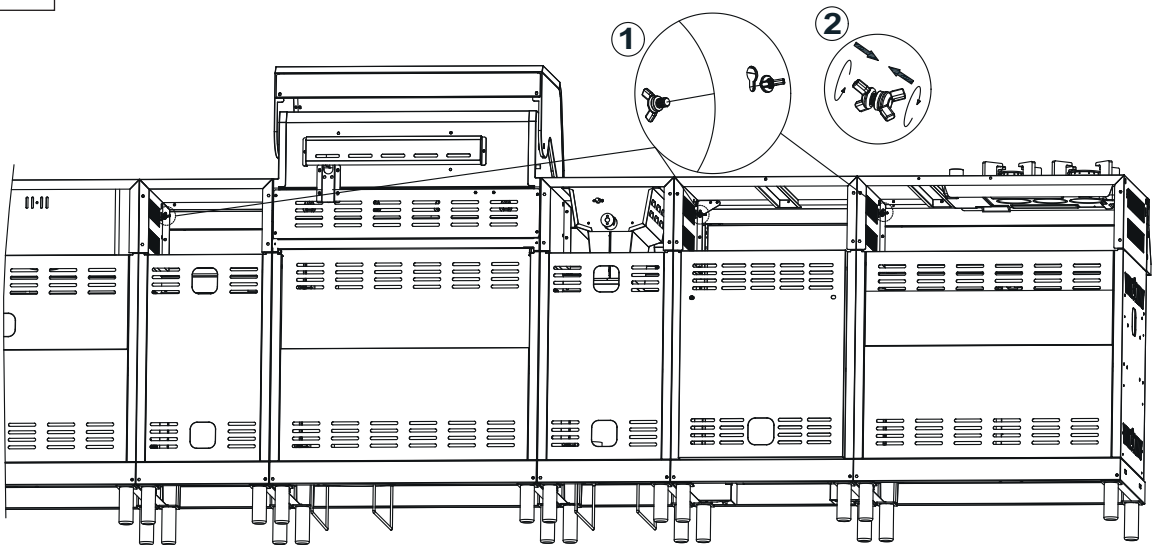

29.

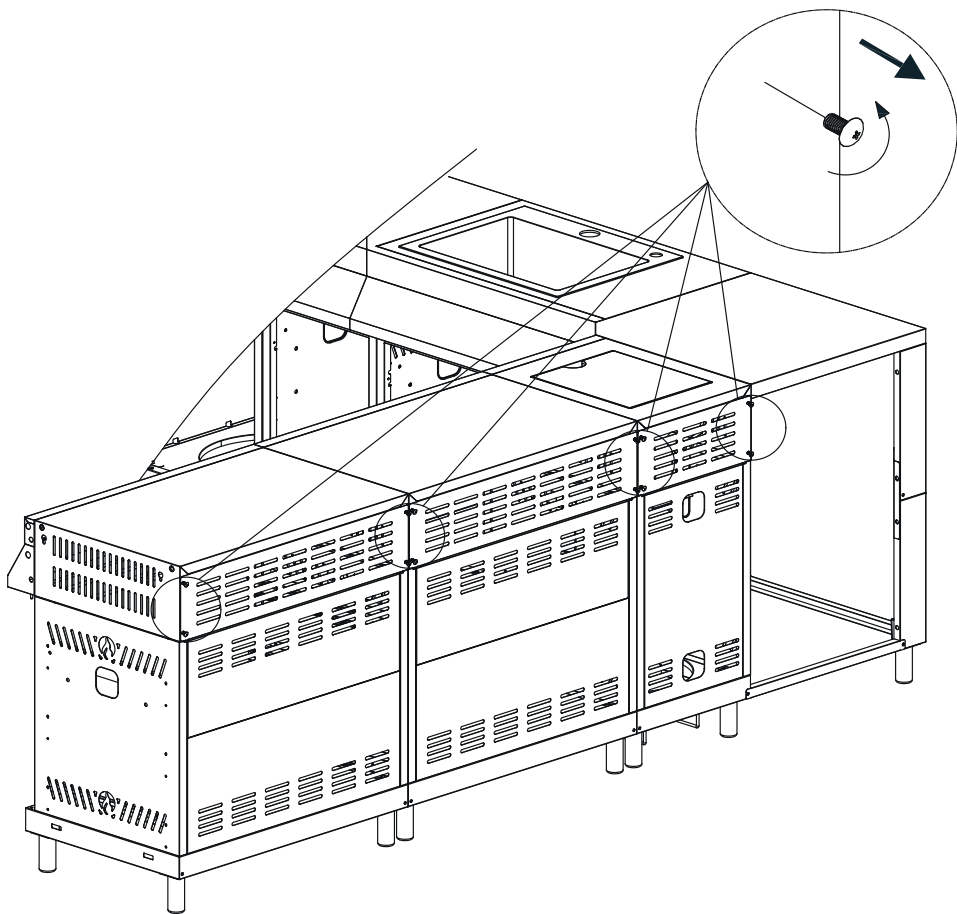

30.

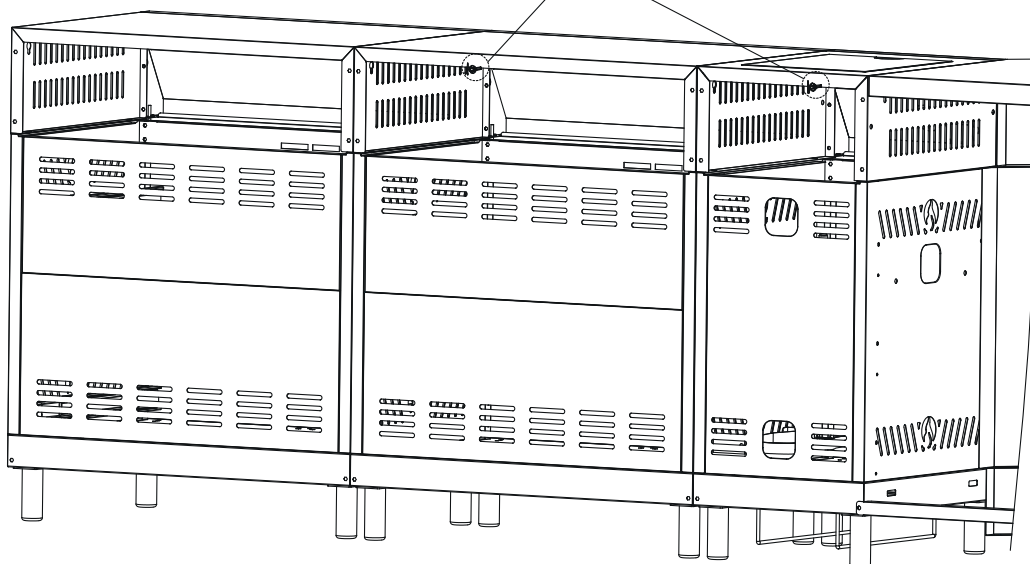
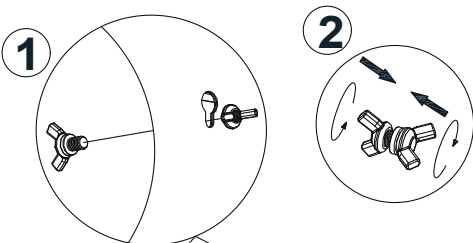
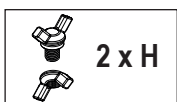

31.

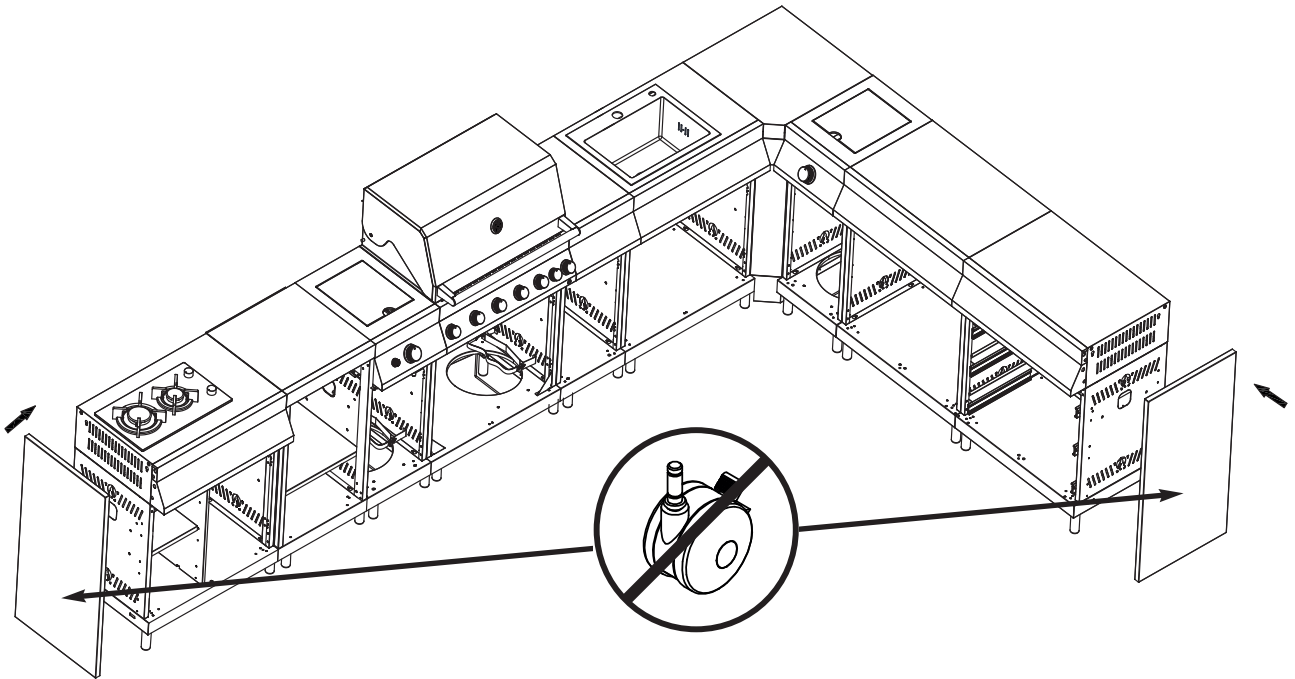

32. Hinweis: Sollten Sie Laufrollen montiert haben, ist es nicht möglich die seitliche Blende zu montieren. Die Laufrollen könnten sich nicht frei drehen.
Note: If you have mounted the wheels, it is not possible to mount the side decoration panels. The caster wheels would not be able to rotate freely.

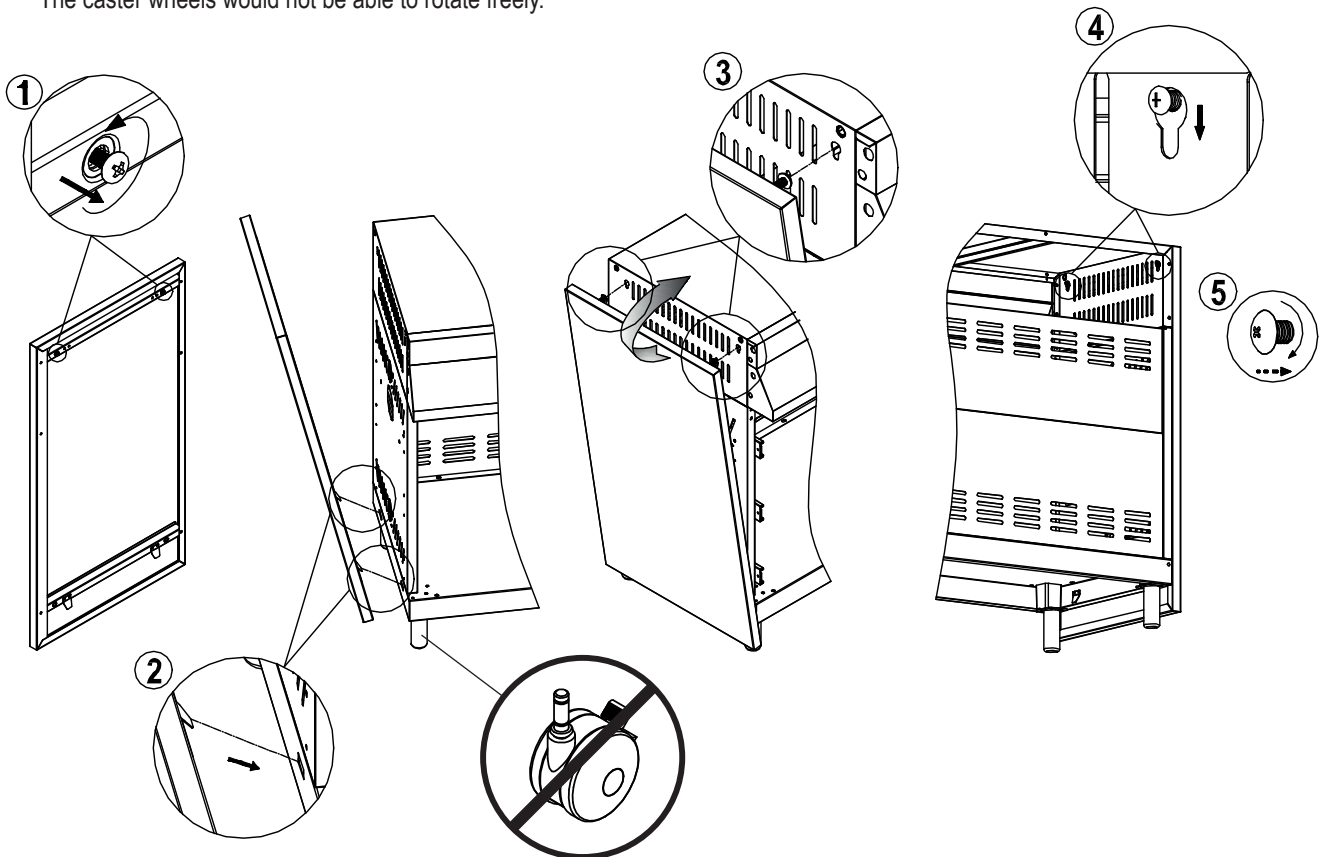

33.

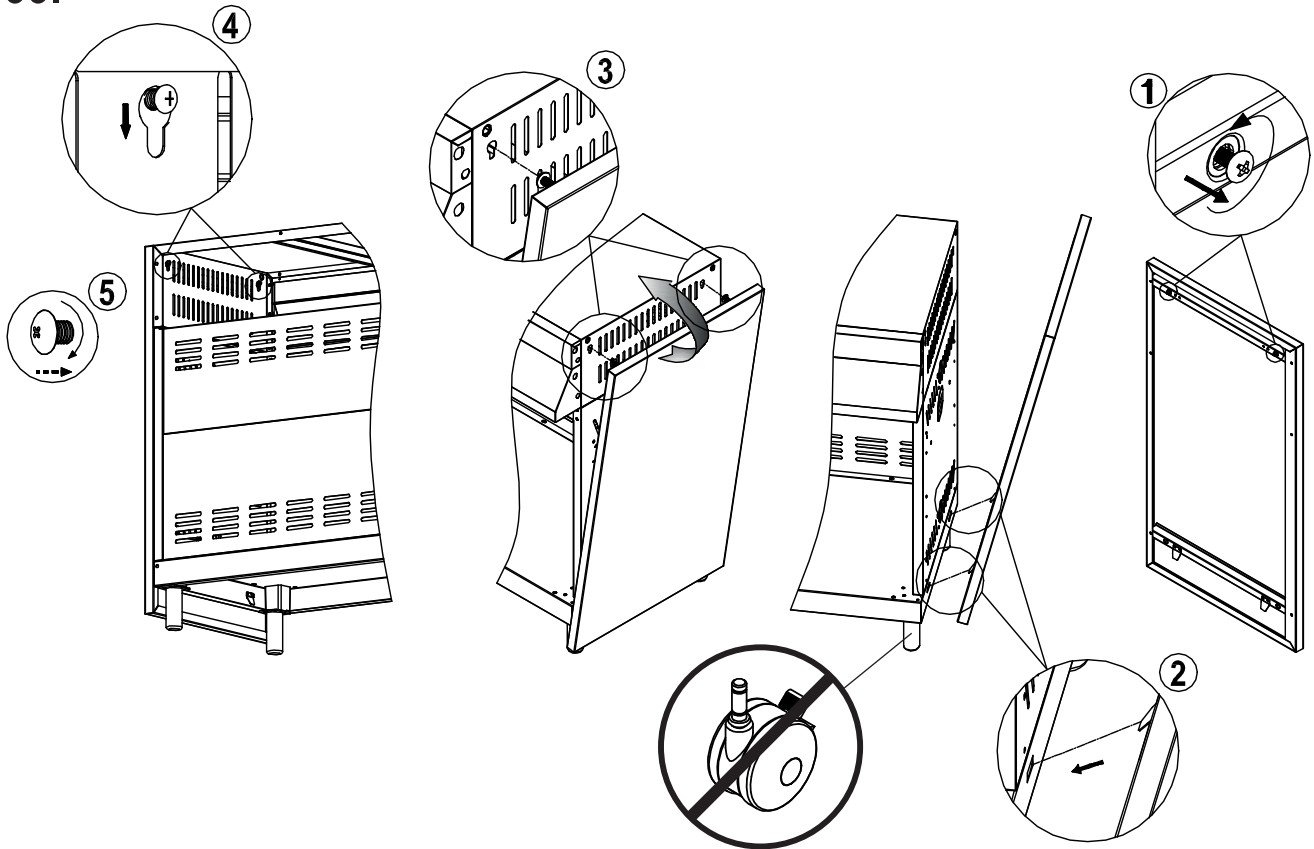

34.

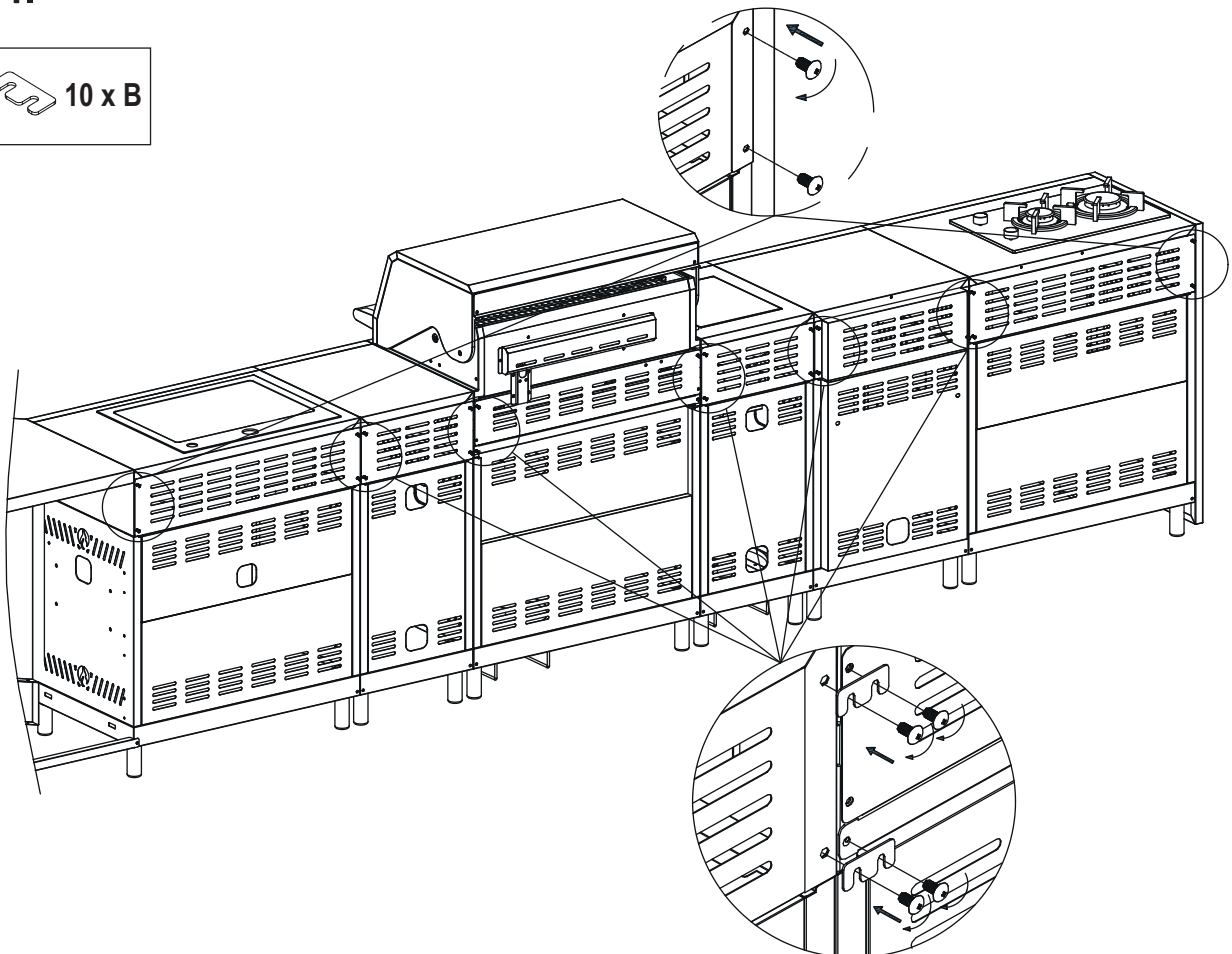
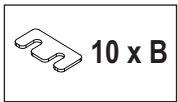

35.

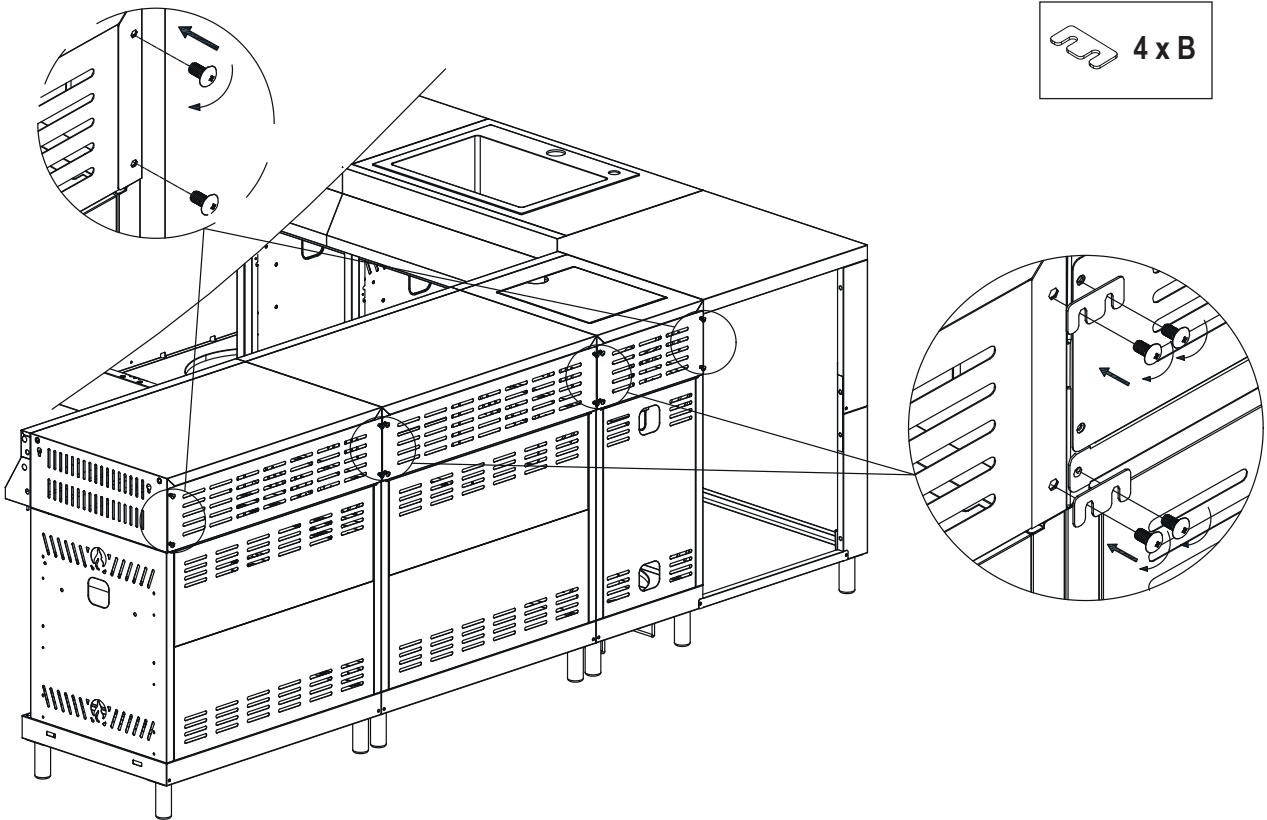

36.

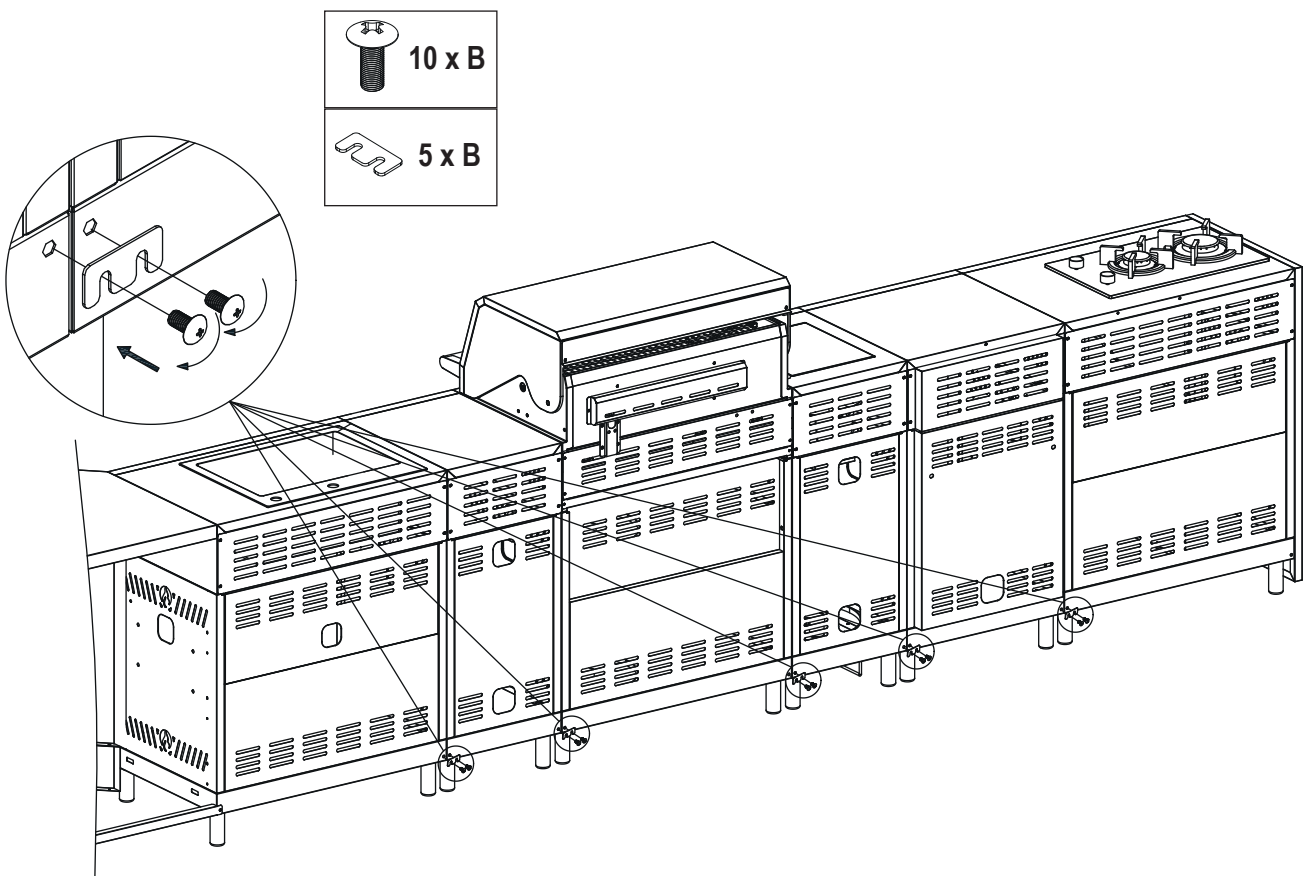

37.

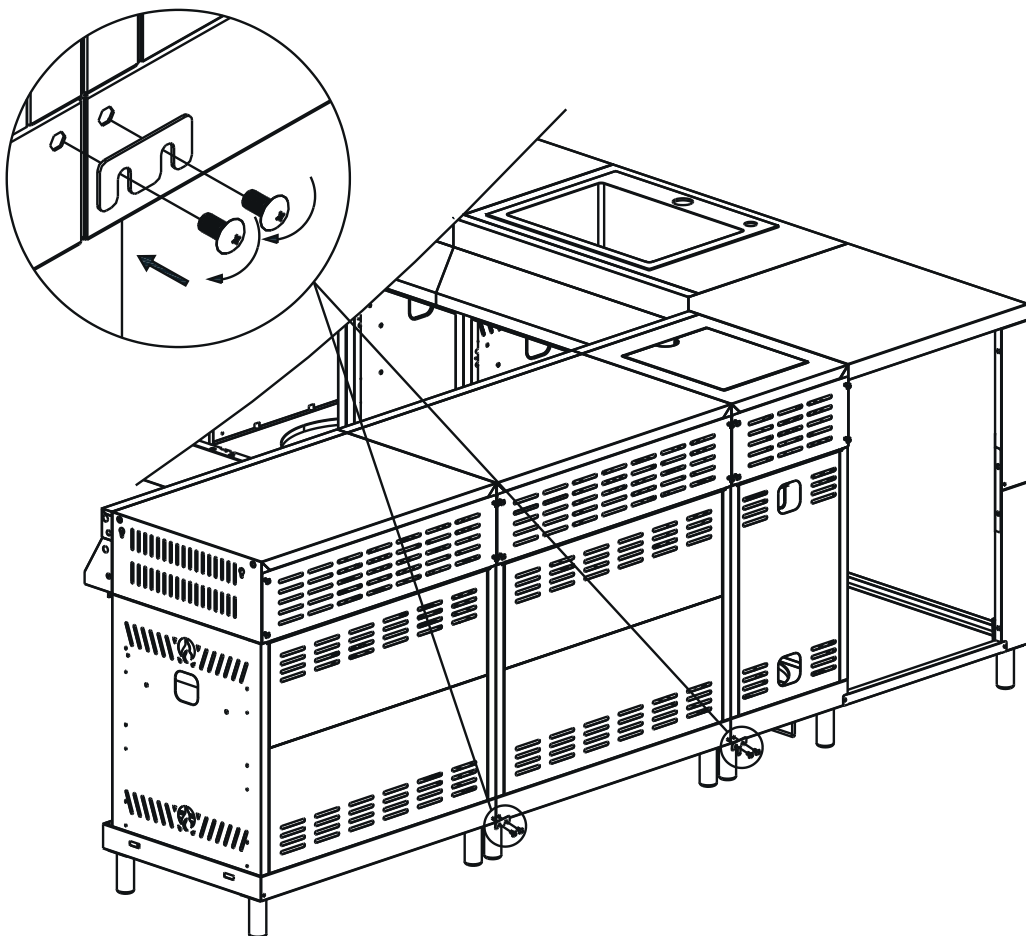
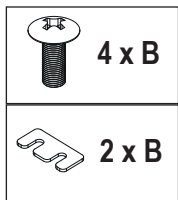

38.

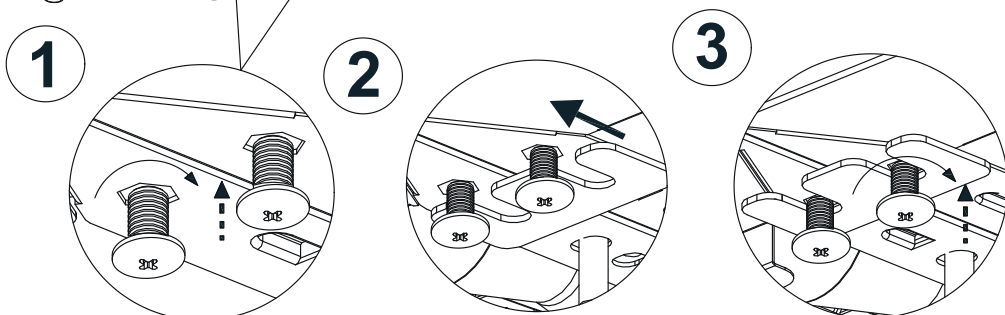
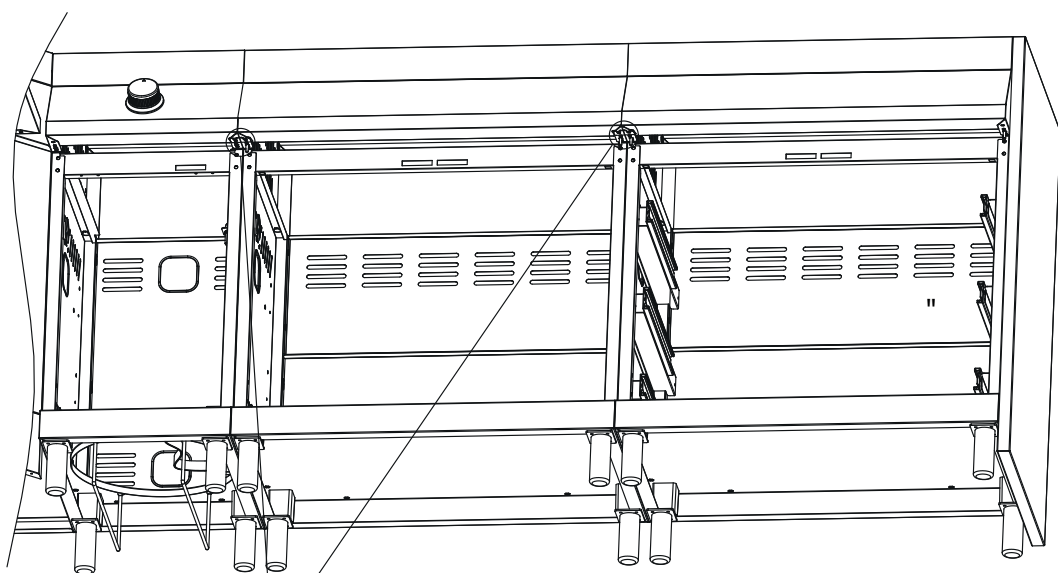
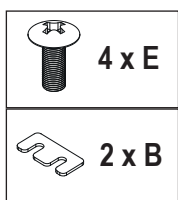

39. Hinweis: Gleichen Sie die Höhe aller Module durch hinein- oder hinausdrehen der Standfüße an.
 Notice: Level the height of all modules to the same height by adjusting the legs.

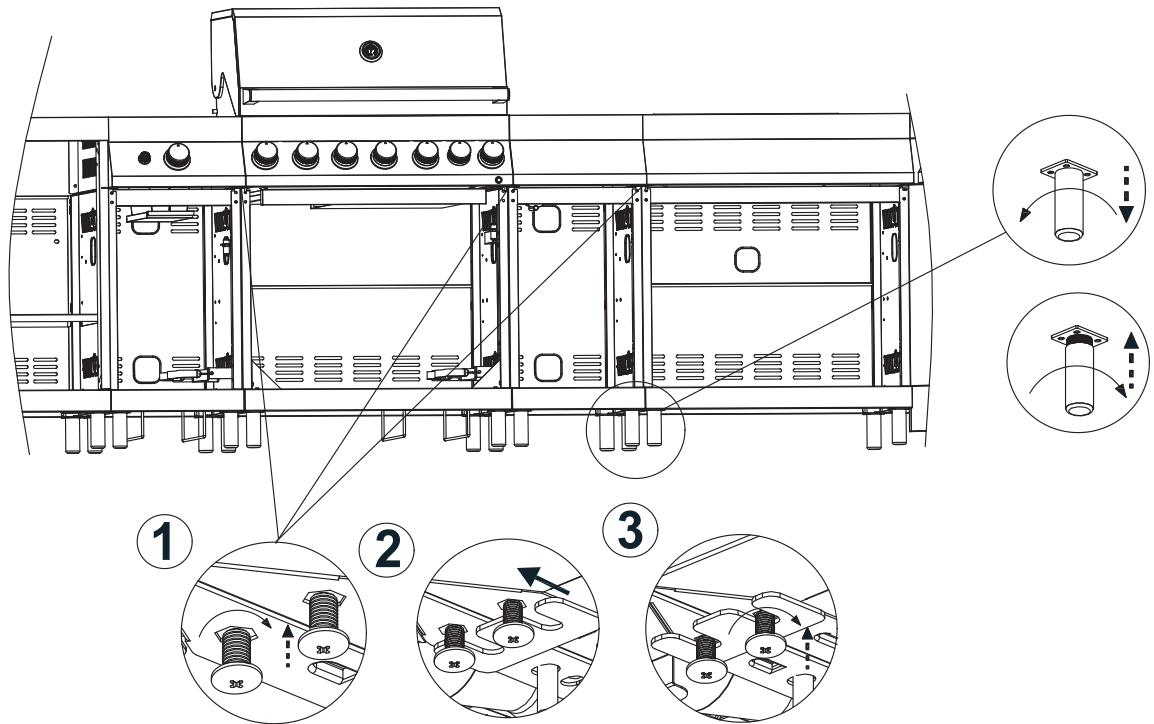
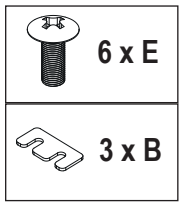

40.

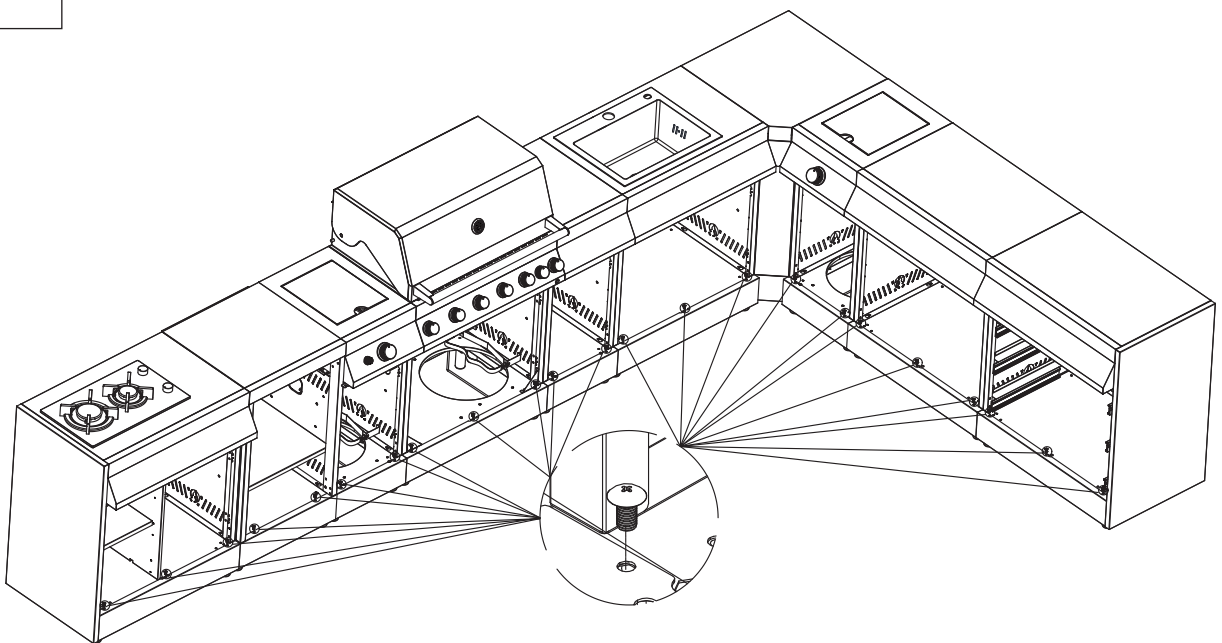
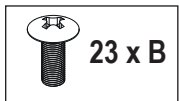

41.

6 x A

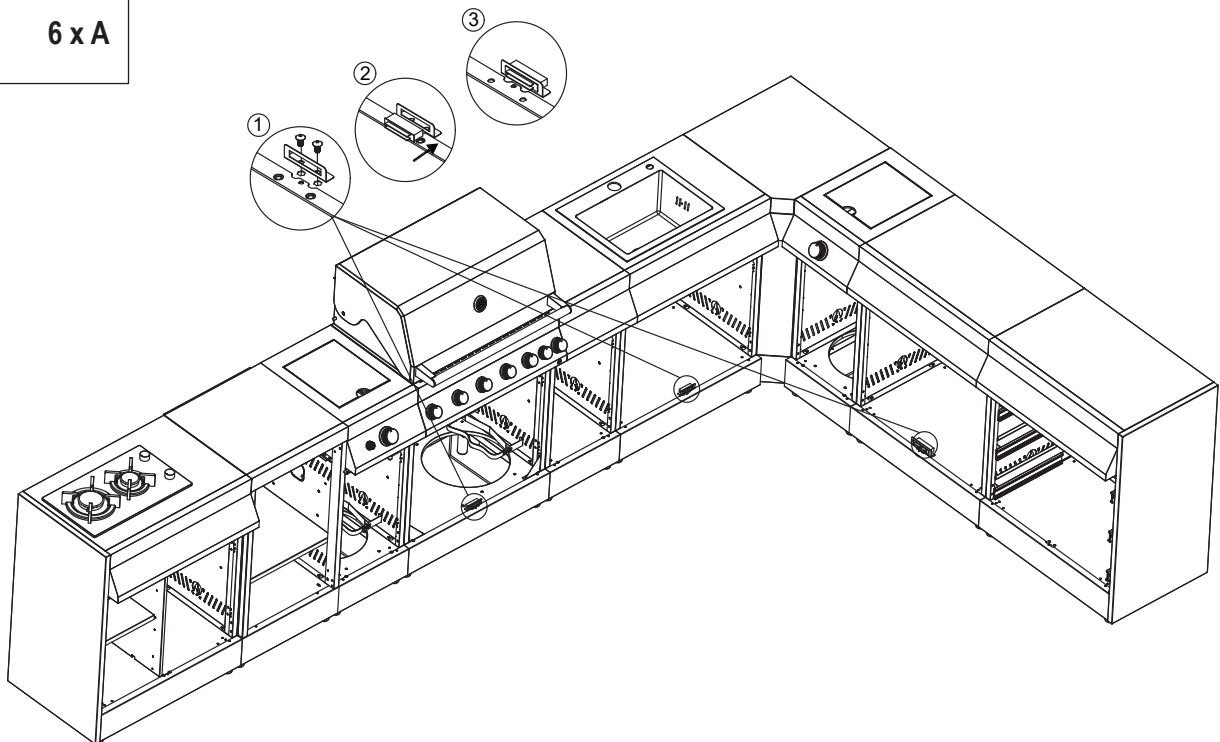

42.

12 x B

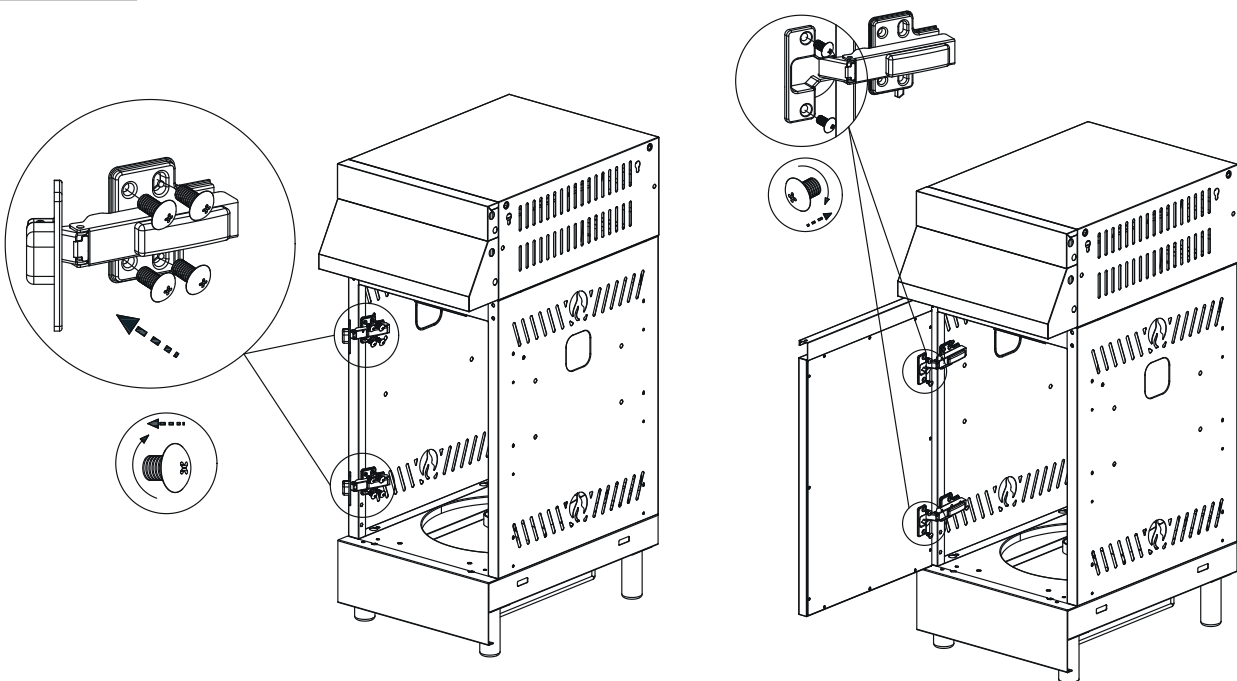

43.

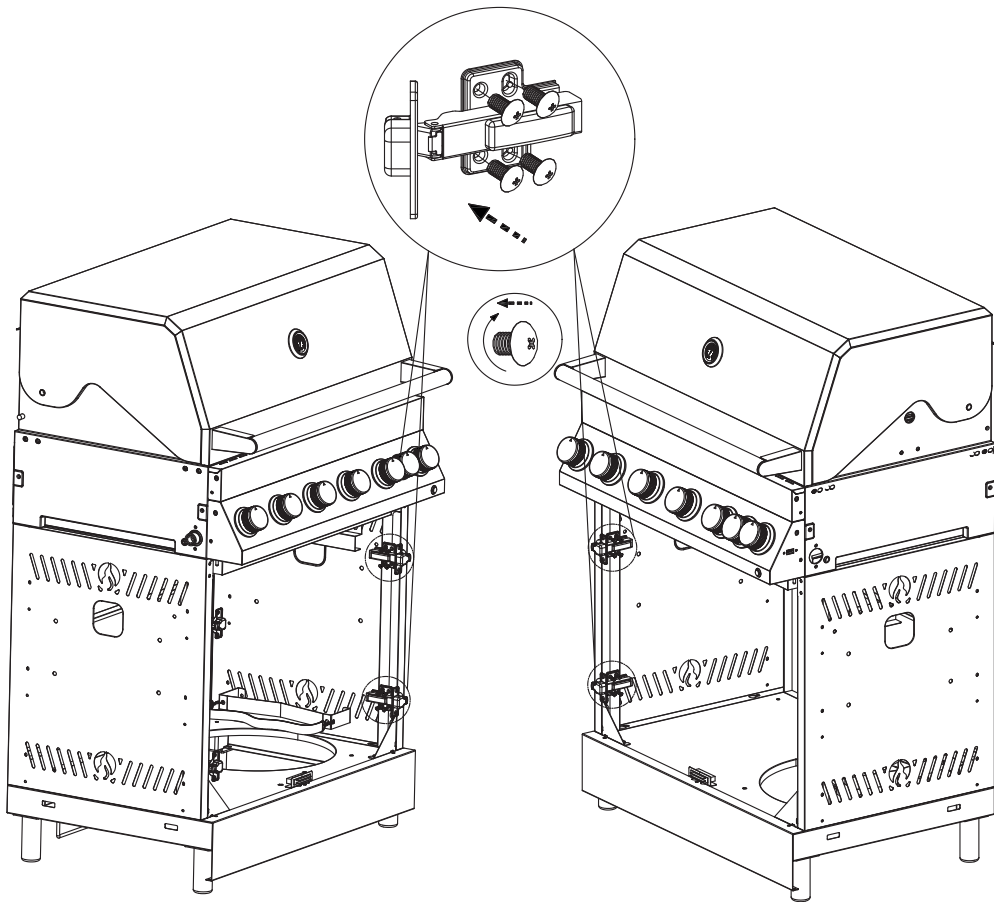

44.

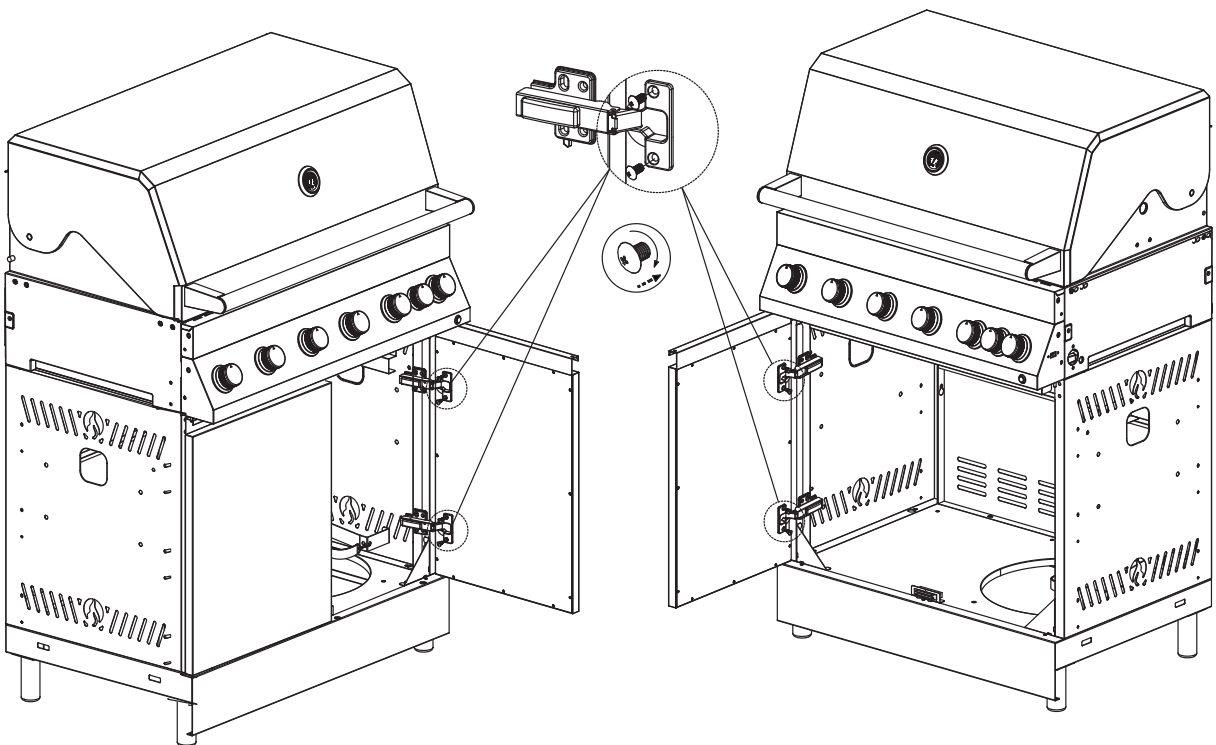

Tips :

If there is a large gap in the door and one side is warped, it is necessary to open the door and tighten or loosen the outer tooth screws to adjust the gap between the doors. Then close the door to confirm whether there is still the problem, if there is a need to repeat the adjustment until there is no problem.

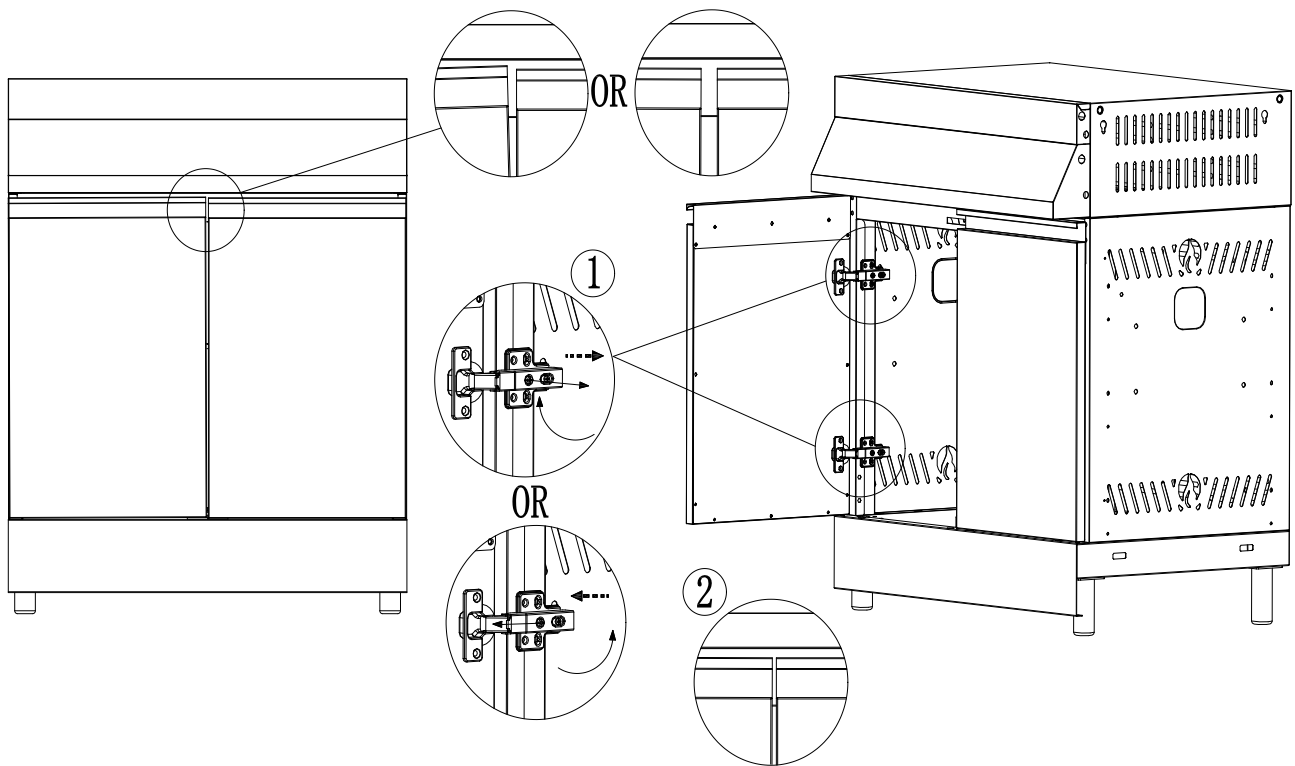

If there's a gap between the door and the front beam, please open the door, tighten or loosen the screws, push the door to the front and back, adjust to the proper position, tighten the screws. Then close the door to confirm whether there is still the problem, if there is a need to repeat the adjustment until there is no problem.

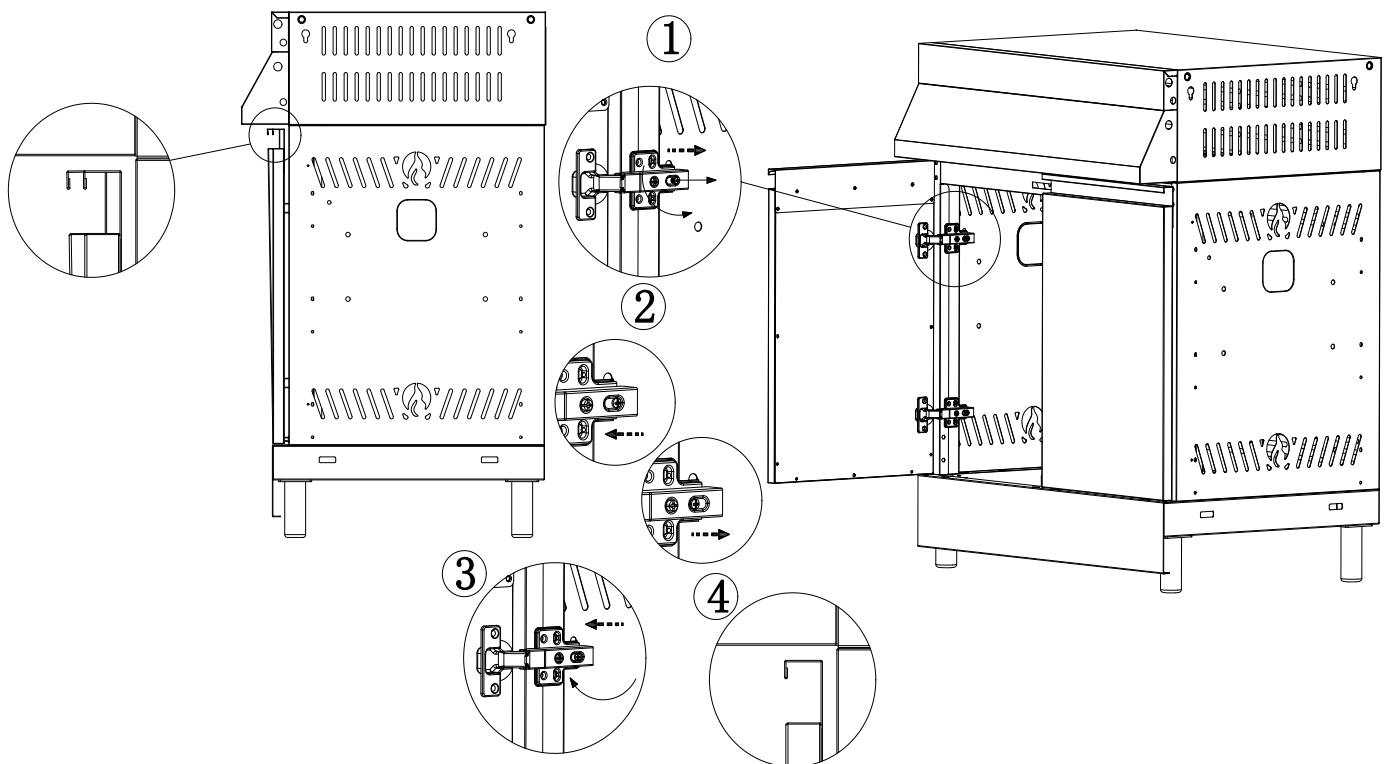

45.

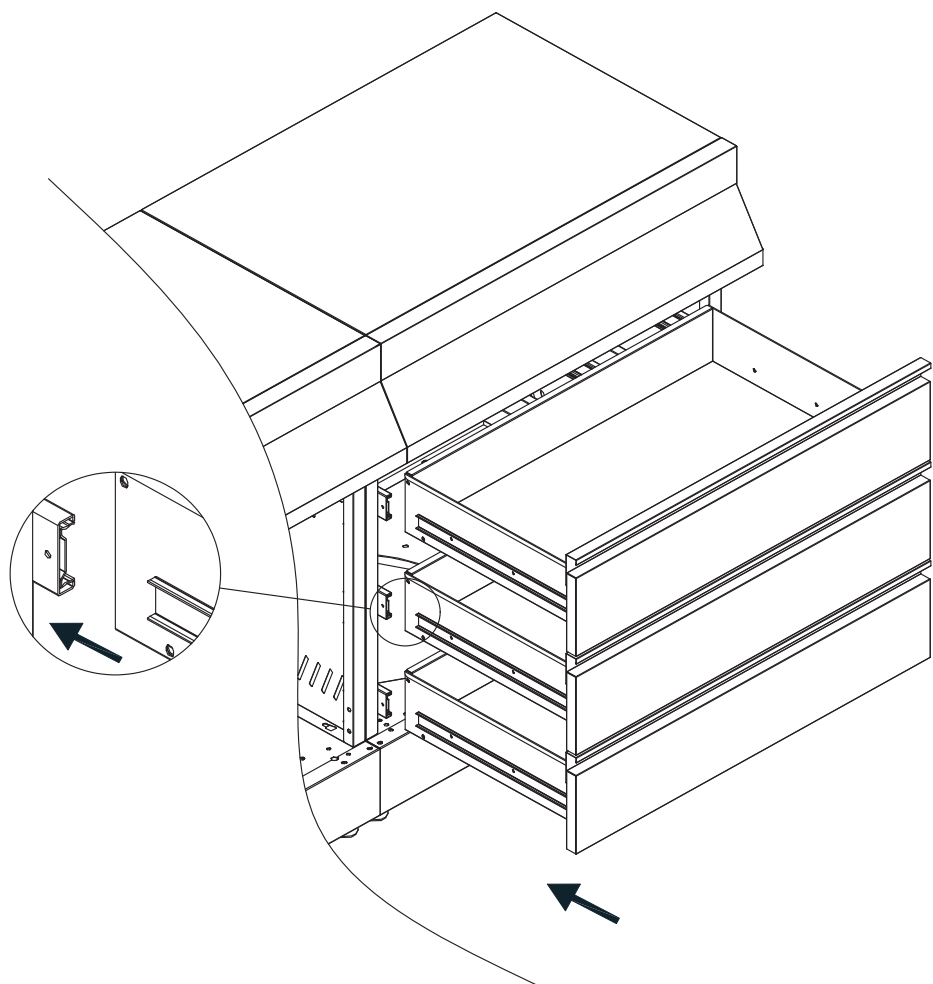

46.

