





	FICHA TÉCNICA	REFERENCIA: F19011-F1012	Última revisión: 12/06/2023																				
DESCRIPCION: JUEGO BANDEJAS GIRATORIAS 180º MODULAR DIAM. 75 / 85																							
COMPOSICIÓN DEL ARTÍCULO																							
PARÁMERTOS	DETALLE																						
EMBALAJE	-1 Ud. por caja - Embolsada																						
ETIQUETADO	- Referencia - Descripción - Unidades - Diametro - Acabado - Código de barras	<div data-bbox="831 1014 1412 1070" style="background-color: #008080; color: white; padding: 2px;"> JUEGO BANDEJAS GIRATORIAS 180º </div> <div data-bbox="874 1079 1085 1111"> Semicircular trays 180º </div> <div data-bbox="852 1142 1090 1391">  </div> <div data-bbox="1141 1097 1412 1417"> <table border="1" style="width: 100%; border-collapse: collapse;"> <tr> <td style="width: 10%;">REF.:</td> <td style="font-weight: bold; font-size: 1.2em;">F19011</td> </tr> <tr> <td>DIÁMETRO / DIAMETER:</td> <td>Ø 75 mm.</td> </tr> <tr> <td>ACABADO / FINISH:</td> <td>Cromo</td> </tr> <tr> <td>EMBALAJE / PACKAGING:</td> <td>1 set</td> </tr> <tr> <td colspan="2" style="text-align: center;">  8 435568 730748 </td> </tr> </table> </div> <div data-bbox="831 1451 1412 1507" style="background-color: #008080; color: white; padding: 2px;"> JUEGO BANDEJAS GIRATORIAS 180º </div> <div data-bbox="874 1516 1085 1547"> Semicircular trays 180º </div> <div data-bbox="852 1568 1090 1816">  </div> <div data-bbox="1141 1534 1412 1854"> <table border="1" style="width: 100%; border-collapse: collapse;"> <tr> <td style="width: 10%;">REF.:</td> <td style="font-weight: bold; font-size: 1.2em;">F19012</td> </tr> <tr> <td>DIÁMETRO / DIAMETER:</td> <td>Ø 85 mm.</td> </tr> <tr> <td>ACABADO / FINISH:</td> <td>Cromo</td> </tr> <tr> <td>EMBALAJE / PACKAGING:</td> <td>1 set</td> </tr> <tr> <td colspan="2" style="text-align: center;">  8 435568 730755 </td> </tr> </table> </div>		REF.:	F19011	DIÁMETRO / DIAMETER:	Ø 75 mm.	ACABADO / FINISH:	Cromo	EMBALAJE / PACKAGING:	1 set	 8 435568 730748		REF.:	F19012	DIÁMETRO / DIAMETER:	Ø 85 mm.	ACABADO / FINISH:	Cromo	EMBALAJE / PACKAGING:	1 set	 8 435568 730755	
REF.:	F19011																						
DIÁMETRO / DIAMETER:	Ø 75 mm.																						
ACABADO / FINISH:	Cromo																						
EMBALAJE / PACKAGING:	1 set																						
 8 435568 730748																							
REF.:	F19012																						
DIÁMETRO / DIAMETER:	Ø 85 mm.																						
ACABADO / FINISH:	Cromo																						
EMBALAJE / PACKAGING:	1 set																						
 8 435568 730755																							
REFERENCIAS	F19011 F19012	<table border="1" style="width: 100%; border-collapse: collapse; font-size: 0.8em;"> <tr> <td style="width: 10%; text-align: center;">Cromo</td> <td style="width: 10%; text-align: center;">180º</td> <td style="width: 20%;"></td> <td style="width: 20%; text-align: center; color: #008080;">Mod. 75</td> <td style="width: 20%; text-align: center; color: #008080;">Mod. 85</td> </tr> <tr> <td>Juego Bandejas</td> <td>Ref.</td> <td style="background-color: #e0e0e0;">F19011</td> <td style="background-color: #e0e0e0;">F19012</td> <td></td> </tr> <tr> <td>SET Bases PS.</td> <td>Ref.</td> <td style="background-color: #e0e0e0;">F19311</td> <td style="background-color: #e0e0e0;">F19312</td> <td></td> </tr> <tr> <td>Embalaje</td> <td></td> <td colspan="3" style="text-align: center;">1 Juego/Set</td> </tr> </table>		Cromo	180º		Mod. 75	Mod. 85	Juego Bandejas	Ref.	F19011	F19012		SET Bases PS.	Ref.	F19311	F19312		Embalaje		1 Juego/Set		
Cromo	180º		Mod. 75	Mod. 85																			
Juego Bandejas	Ref.	F19011	F19012																				
SET Bases PS.	Ref.	F19311	F19312																				
Embalaje		1 Juego/Set																					



ACABADO	- Cromo	Comprobar con muestra
LONGITUD Y MEDIDAS	- Longitud total: 800 – 900 mm (± 1 mm)	-Según referencia
	- Altura total: 700 – 800 mm (± 1 mm)	- Según referencia
	- Diámetro: 750 – 850 mm (± 1 mm)	- Según referencia
	- Diámetro varilla horizontal exterior: 8 mm (± 0.1 mm)	
	- Diámetro varilla horizontal interior: 3 mm (± 0.1 mm)	
	- Diámetro varilla lateral: 5 mm (± 0.1 mm)	

IMAGEN DEL PRODUCTO



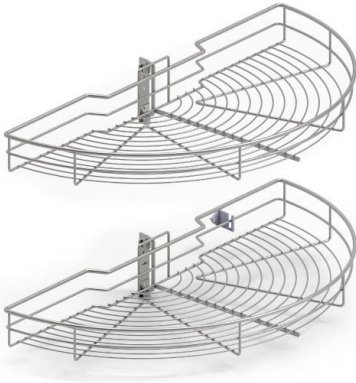
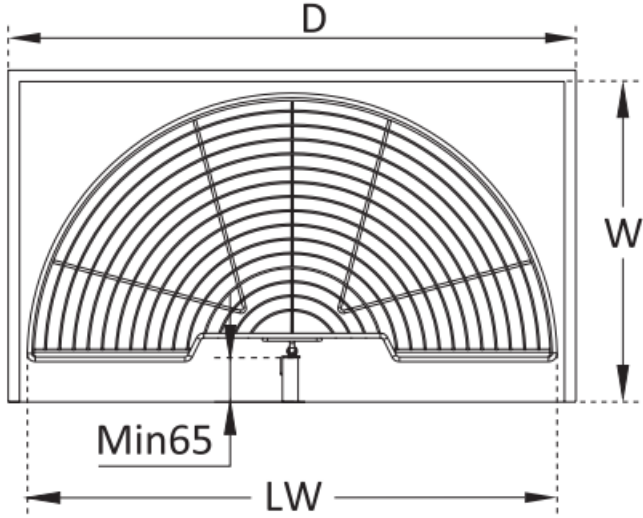

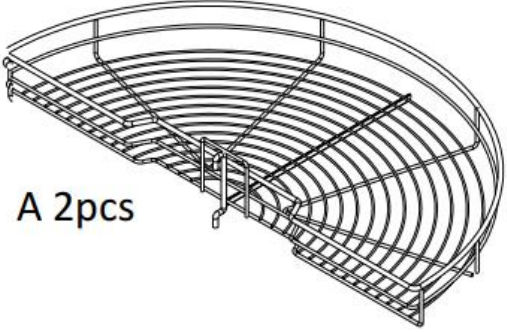
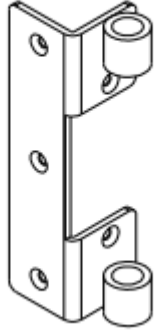
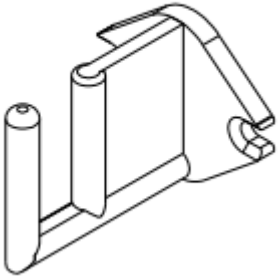
IMAGEN CATÁLOGO	IMAGEN TÉCNICA
	

MEDIDAS APLICABLES AL MÓDULO
APPLICABLE DIMENSIONS OF THE CABINET

REF.	Ø	H ALTURA HEIGHT	D ANCHO MÍNIMO WIDTH MINIMUM	PUERTA MÍNIMA DOOR MINIMUM	W FONDO MÍNIMO DEPTH MINIMUM	LW INTERIOR MÓDULO INSIDE MODULE
F19011	75	700-800	800	400	470	764
F19012	85	700-800	900	450	510	864

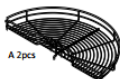
ELEMENTOS QUE COMPONEN EL PRODUCTO			
REF.	DESCRIPCIÓN	UDS.	IMAGEN
-	Bandeja Semicircular	2	<p>A 2pcs</p> 
-	Elemento fijacion Bandeja - Modulo	2	<p>B 2pcs</p> 
-	Agarre Modulo movil – Bandeja	1	<p>C 1pcs</p> 
-	Tapones Embellecedor	4	<p>D 4pcs</p> 

-	Tornillos 4 x 16	12	<p>E 12pcs</p>  <p>ST4*16</p>
---	------------------	----	--

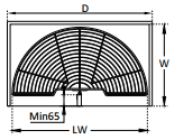
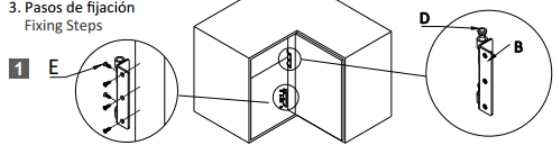
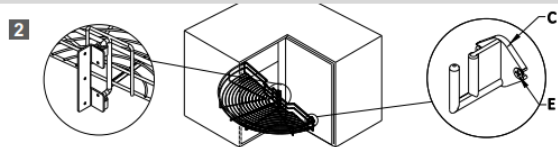
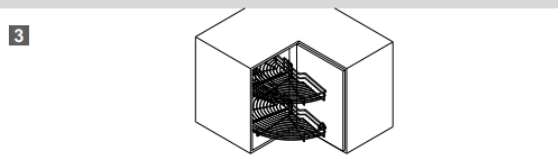
-	<p>Hoja Instrucciones de montaje</p> <ul style="list-style-type: none"> • Español • Inglés 	1	<p>Juego Bandejas Giratorias 180° 180° REVOLVING BASKET 2 LEVELS F19011-F19012</p> <p>INSTRUCCIONES DE MONTAJE / ASSEMBLY INSTRUCTIONS</p> <p>1. Componentes Components</p> <p>A 2pcs B 2pcs C 1pcs D 4pcs E 12pcs</p>      <p>2. Medidas módulo (Derecha/Izquierda): Cabinet Size (can fix on left or right):</p>  <p>Bisagra / Hinge 110°</p> <table border="1"> <thead> <tr> <th colspan="7">MEDIDAS APPLICABLES AL MÓDULO APPLICABLE DIMENSIONS OF THE CABINET</th> </tr> <tr> <th>IND.</th> <th>SP.</th> <th>ANCHO WIDTH</th> <th>PROFUND. DEPTH</th> <th>ALTEZA DOOR HEIGHT</th> <th>ANCHO DOOR WIDTH</th> <th>ANCHO Módulo CABINET</th> </tr> </thead> <tbody> <tr> <td>F19011</td> <td>75</td> <td>700-800</td> <td>800</td> <td>400</td> <td>470</td> <td>764</td> </tr> <tr> <td>F19012</td> <td>85</td> <td>700-800</td> <td>900</td> <td>450</td> <td>510</td> <td>864</td> </tr> </tbody> </table> <p>3. Pasos de fijación Fixing Steps</p>   	MEDIDAS APPLICABLES AL MÓDULO APPLICABLE DIMENSIONS OF THE CABINET							IND.	SP.	ANCHO WIDTH	PROFUND. DEPTH	ALTEZA DOOR HEIGHT	ANCHO DOOR WIDTH	ANCHO Módulo CABINET	F19011	75	700-800	800	400	470	764	F19012	85	700-800	900	450	510	864
MEDIDAS APPLICABLES AL MÓDULO APPLICABLE DIMENSIONS OF THE CABINET																															
IND.	SP.	ANCHO WIDTH	PROFUND. DEPTH	ALTEZA DOOR HEIGHT	ANCHO DOOR WIDTH	ANCHO Módulo CABINET																									
F19011	75	700-800	800	400	470	764																									
F19012	85	700-800	900	450	510	864																									

OBSERVACIONES

CADA BANDEJA SOPORTA 12 KG



**Bisagra / Hinge
110°**