

RAIL EN APPLIQUE · RAIL · SCHIENE · KOĽAJNICA · PŘEKRYVNÁ KOLEJNICE  
 Porte coulissante · Sliding door · Schiebetür · Posuvné dvere · Posuvné dveře

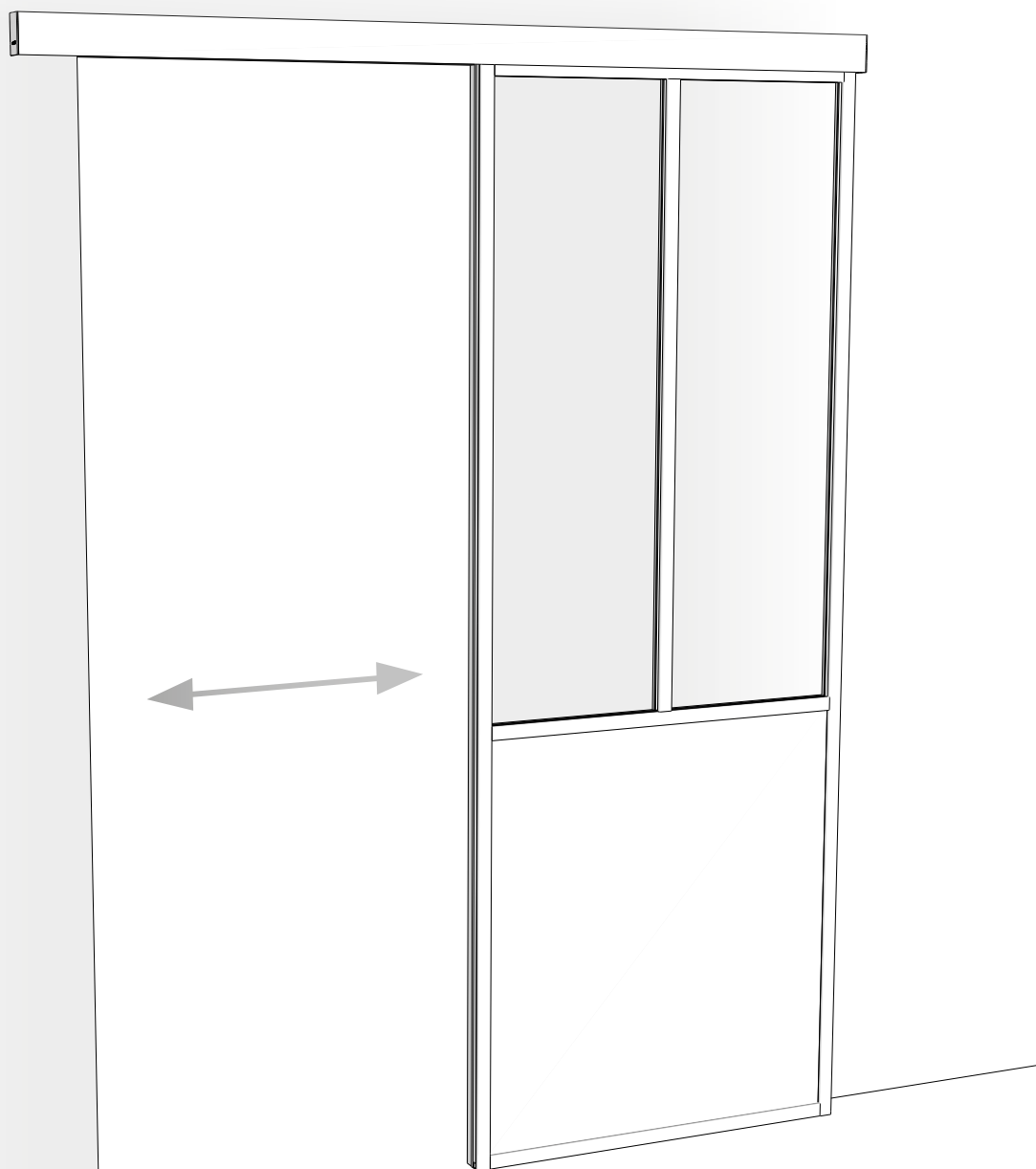

**MATÉRIEL NÉCESSAIRE / NEEDED TOOLS / BENÖTIGTE WERKZEUGE / POTREBNÝ MATERIÁL / POTŘEBNÉ MATERIÁLY**  
 (non fourni / not provided / nicht im Lieferumfang enthalten / nedodáva sa / nedodává se)

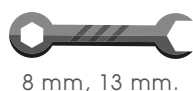
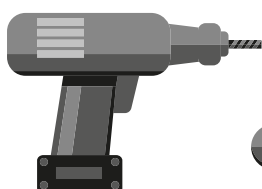

8 mm, 13 mm.



3 mm  
4 mm



Maillet  
Rubber mallet  
Gummihammer  
Palička  
Palička

COMPOSITION DE VOTRE COLIS / INCLUDED IN THE PACKAGE / PAKETINHALT /  
ZLOŽENIE VÁŠHO BALÍKA / OBSAH VAŠEHO BALÍČKU

A  
X1



B  
X1



C  
X2

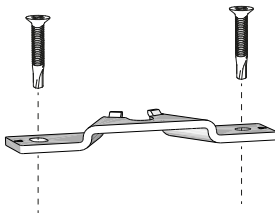

D  
X5

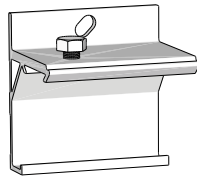

E  
X2

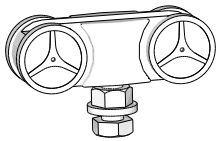

F  
X2

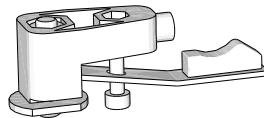

G  
X3



H  
X1

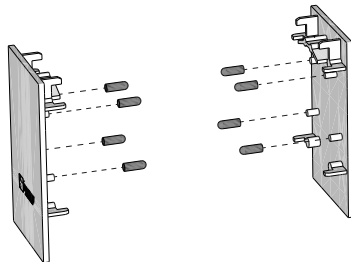

I  
X1

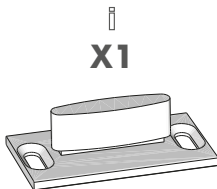

J  
X1



ÉTAPE 1 - STEP 1 - SCHRITT 1 - FÁZA 1 - KROK 1

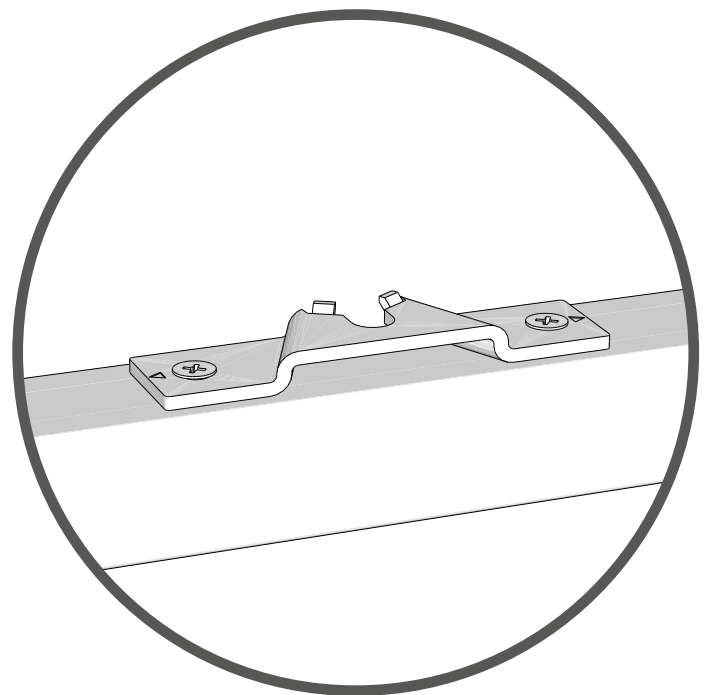
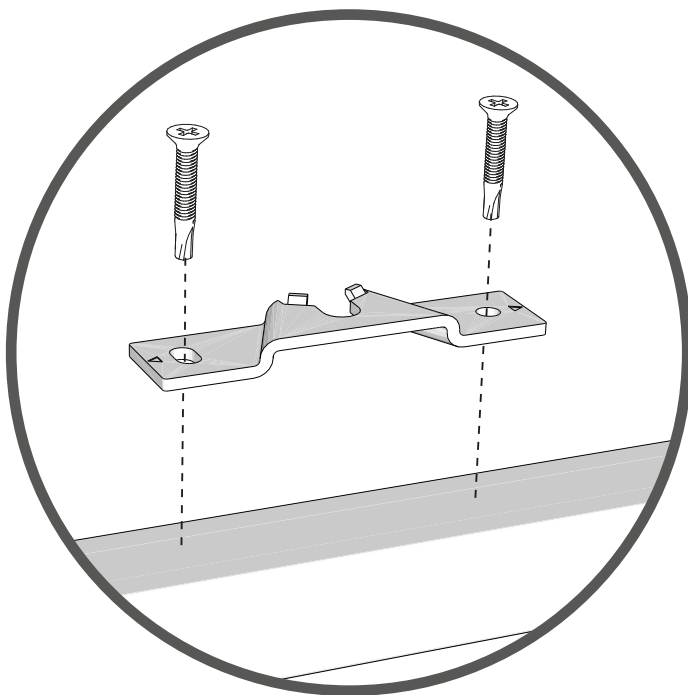
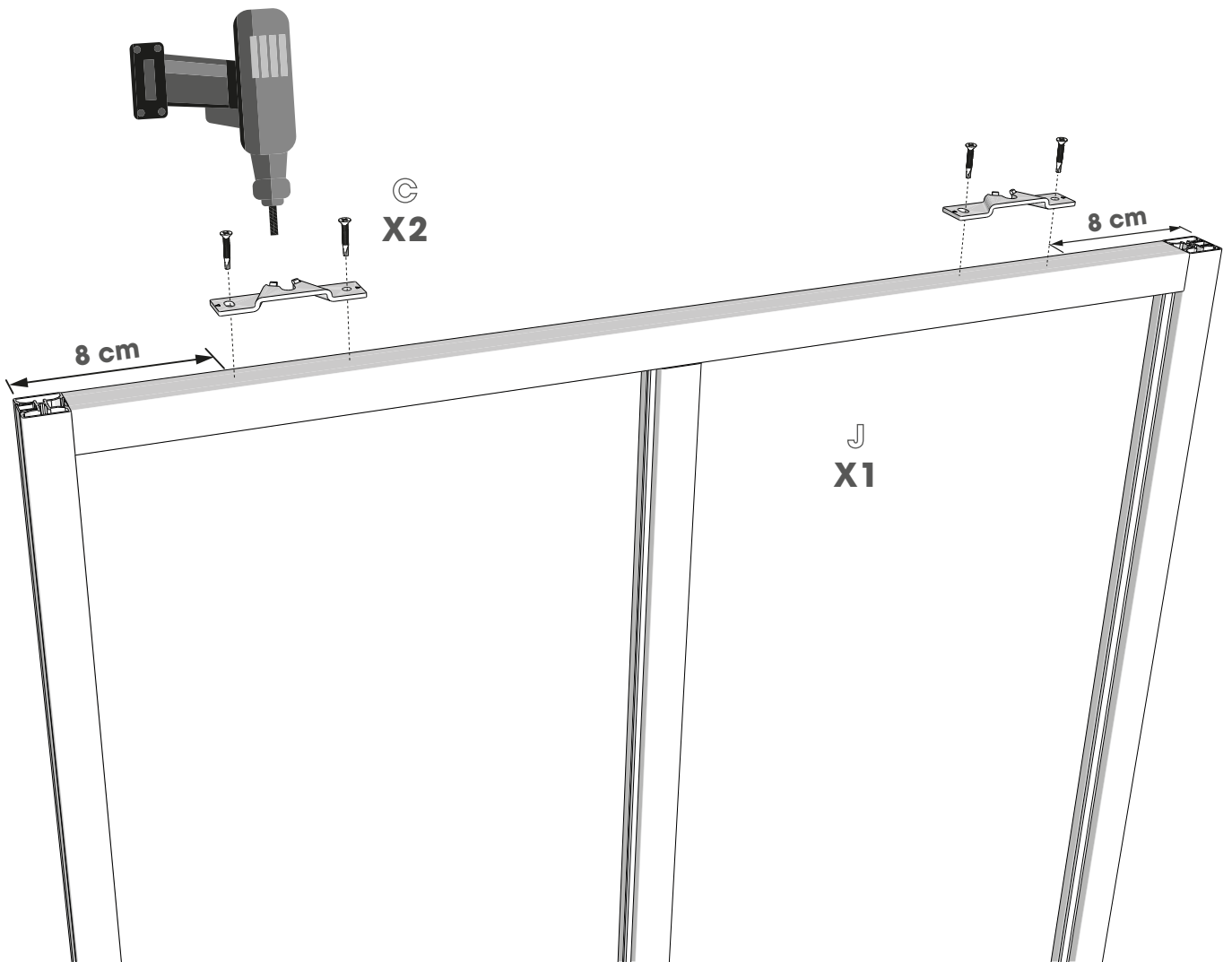
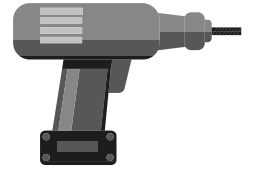

ÉTAPE 2 - STEP 2 - SCHRITT 2 - FÁZA 2 - KROK 2



8 mm

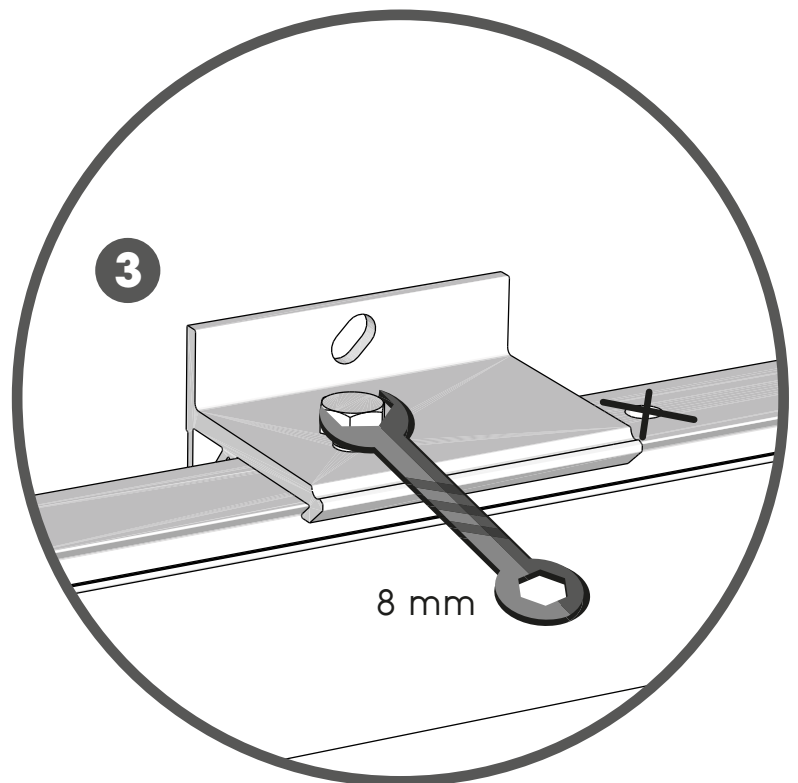
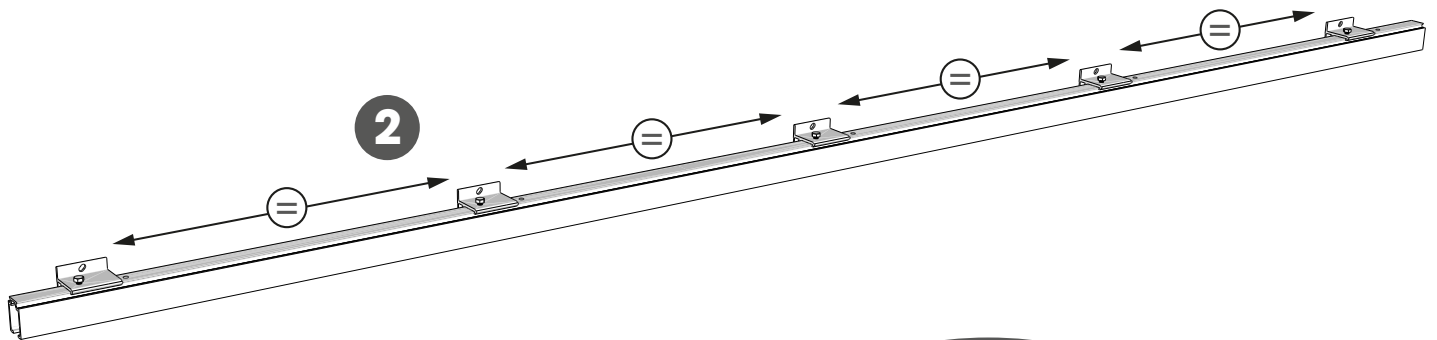
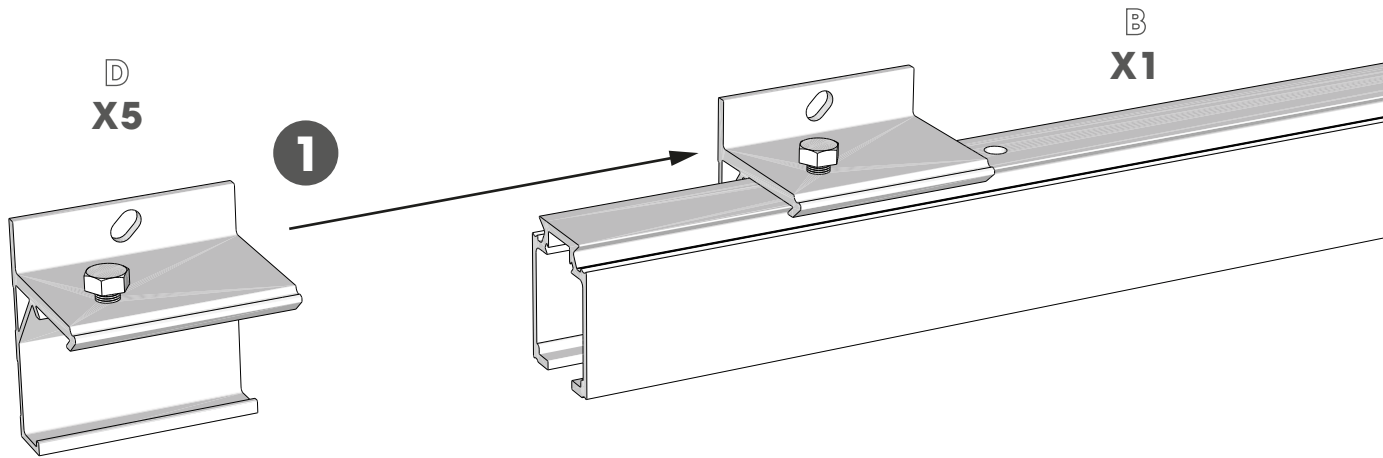

# ÉTAPE 2 - STEP 2 - SCHRITT 2 - FÁZA 2 - KROK 2

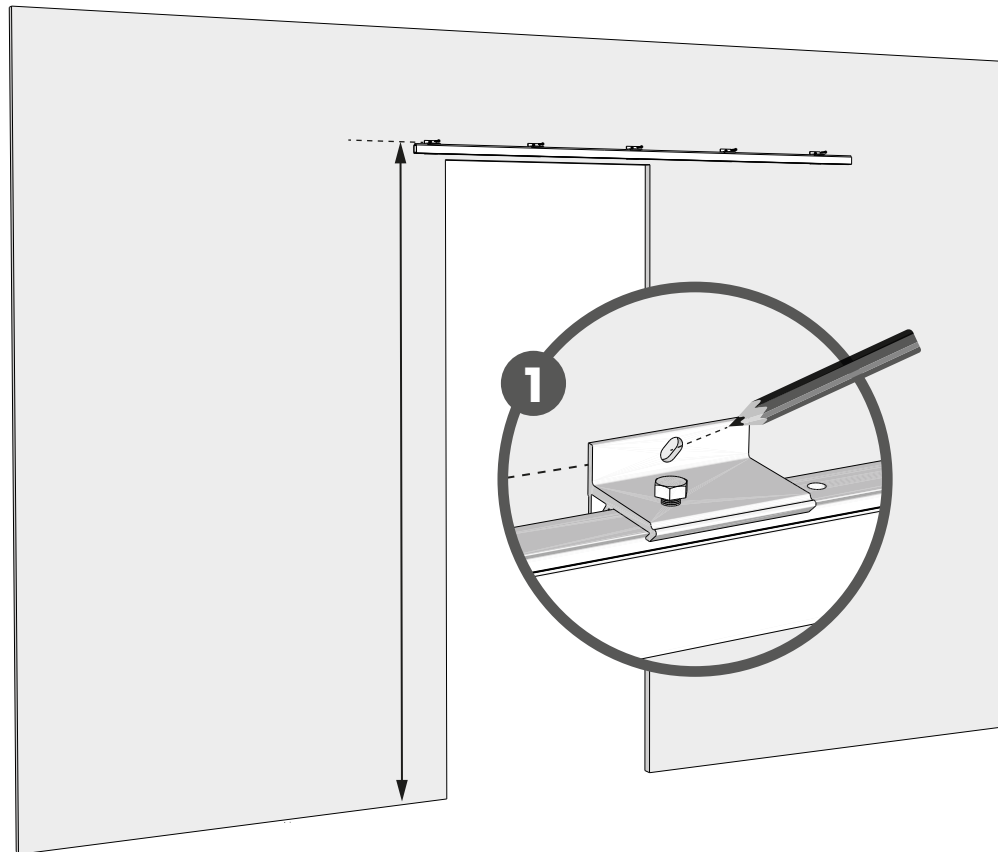
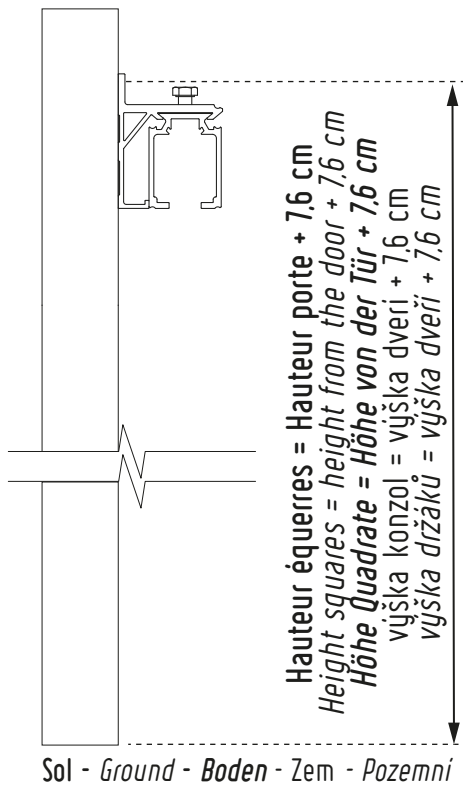
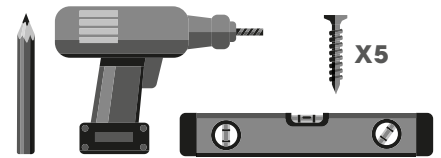

Fixation non fournie, à adapter à votre support.  
 Screw (not provided) to adapt accordingly to your support.  
 Befestigungsmaterial ist nicht im Lieferumfang enthalten und muss separat erworben werden.  
 Upevňovacie prvky nie sú súčasťou dodávky, je potrebné ich prispôbiť vašej podpore.  
 Upevňovací prvky nejsou součástí dodávky, je třeba je přizpůsobit vaší podpěře.

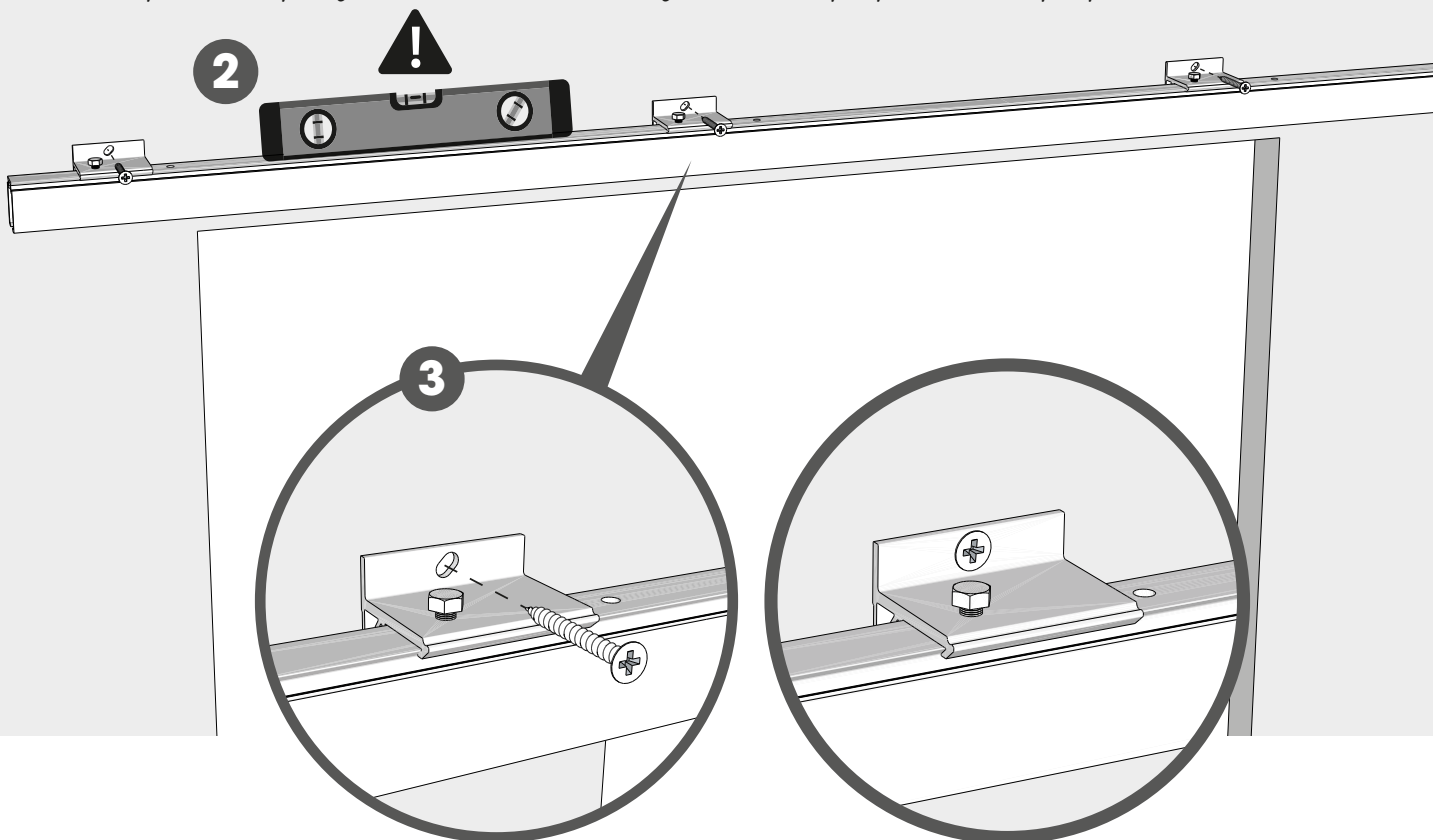

ÉTAPE 4 - STEP 4 - SCHRITT 4 - FÁZA 4 - KROK 4



13 mm

E  
X2

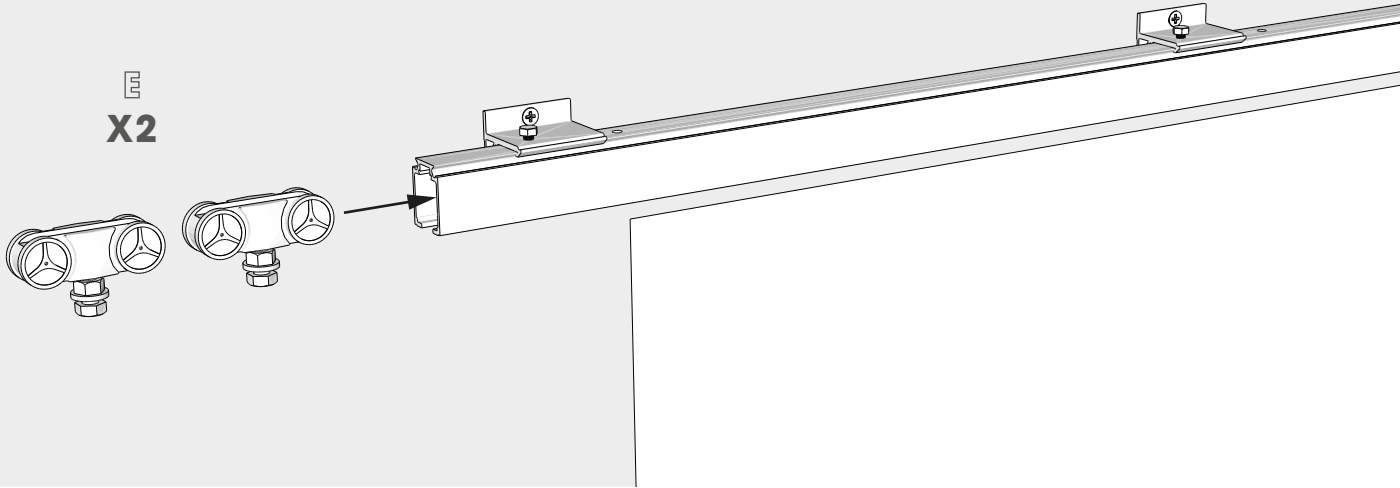

J  
X1

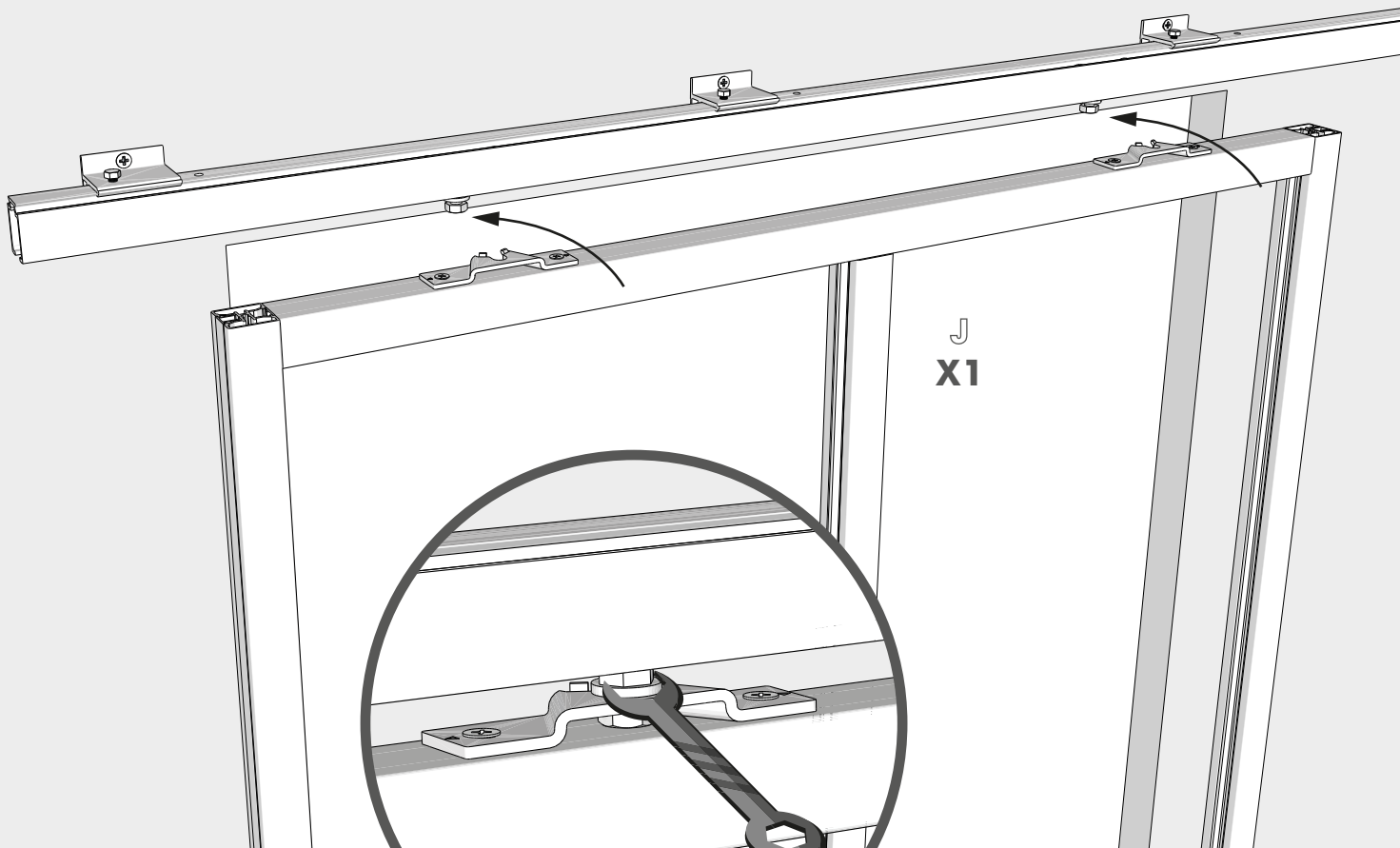

13 mm

# ÉTAPE 5 - STEP 5 - SCHRITT 5 - FÁZA 5 - KROK 5

3 mm  
4 mm

F  
X1

1

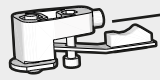

Porte en position fermée  
Door closed position  
Position der Tür geschlossen  
Dvere v zatvorenej polohe  
Dveře v zavřené poloze

2

Porte en position fermée  
Door closed position  
Position der Tür geschlossen  
Dvere v zatvorenej polohe  
Dveře v zavřené poloze

3

4 mm 3 mm

Ouvrez la porte pour serrer la butée.  
Open the door to tighten the stop.  
Öffnen Sie die Tür um den Anschlag fest zu ziehen.  
Otvorte dvere a utiahnite zarážku.  
Otevřete dveře a utáhněte zarážku.

ÉTAPE 6 - STEP 6 - SCHRITT 6 - FÁZA 6 - KROK 6

3 mm  
4 mm

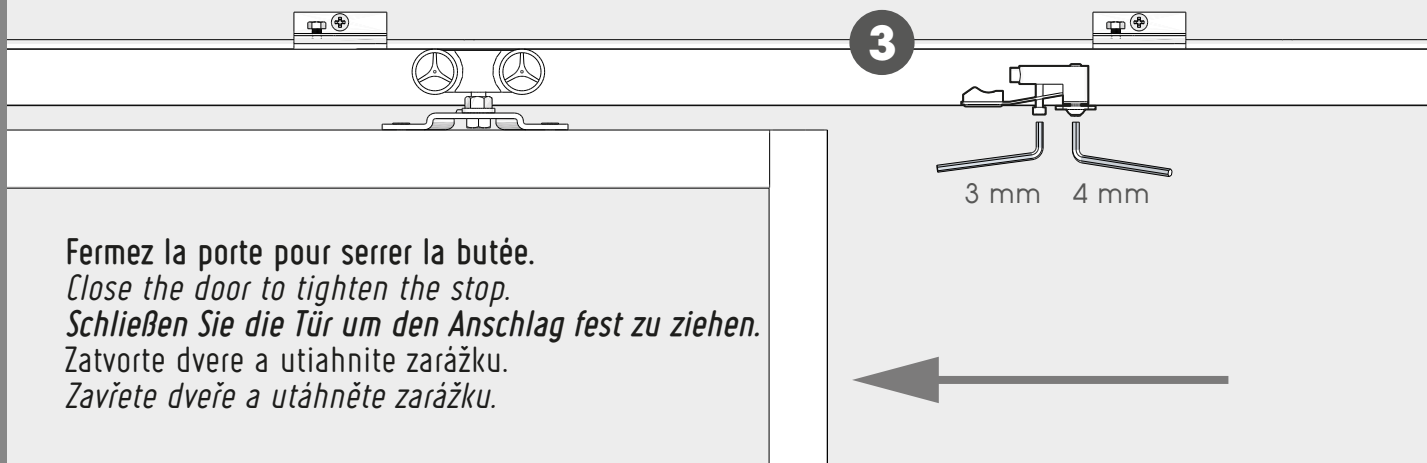
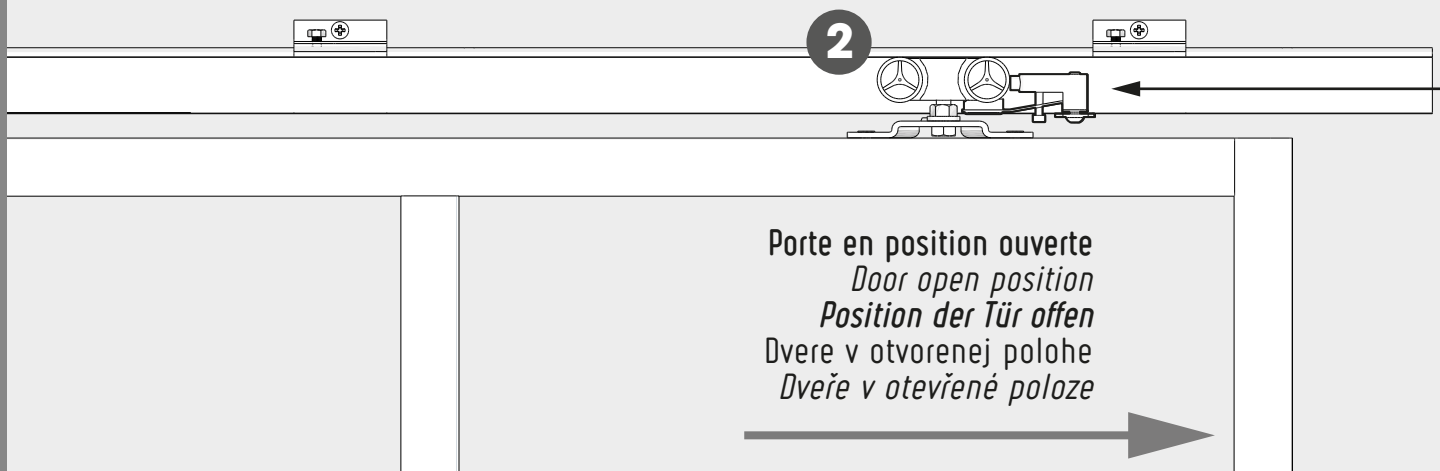
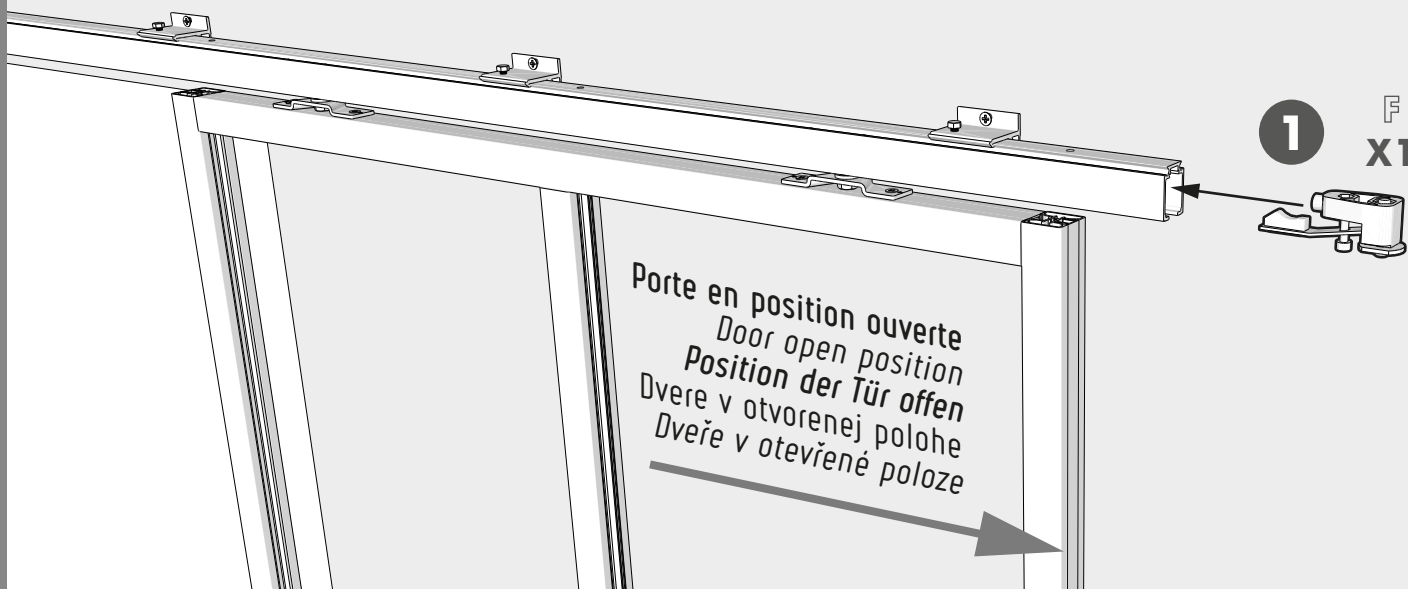



ÉTAPE 7 - STEP 7 - SCHRITT 7 - FÁZA 7 - KROK 7

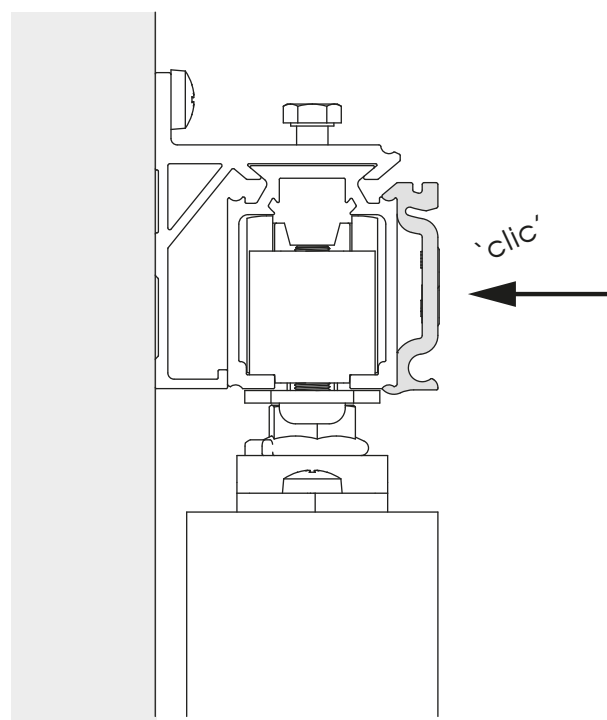
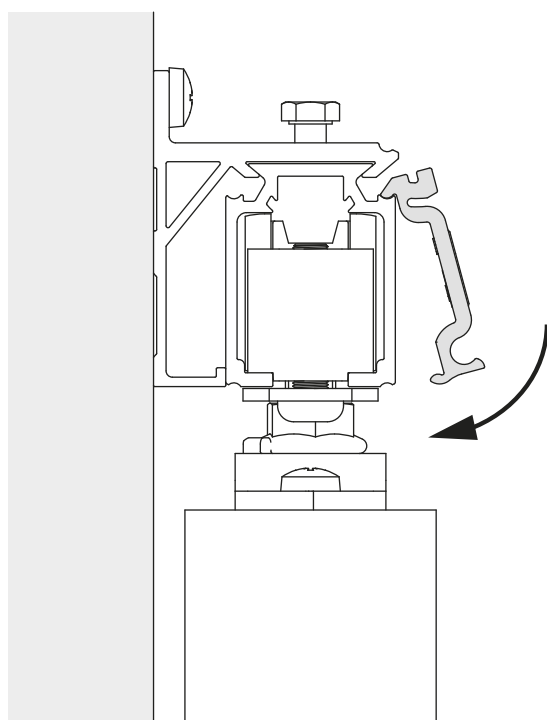
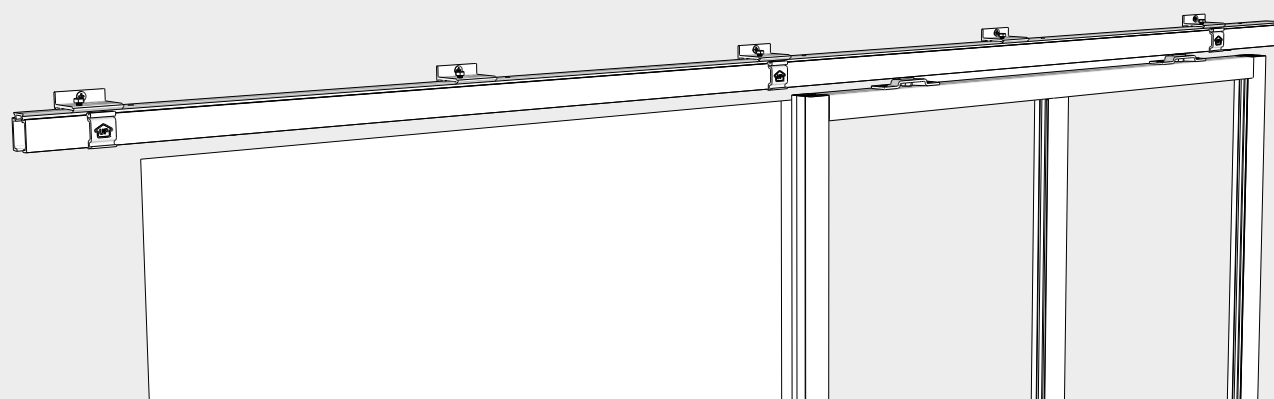
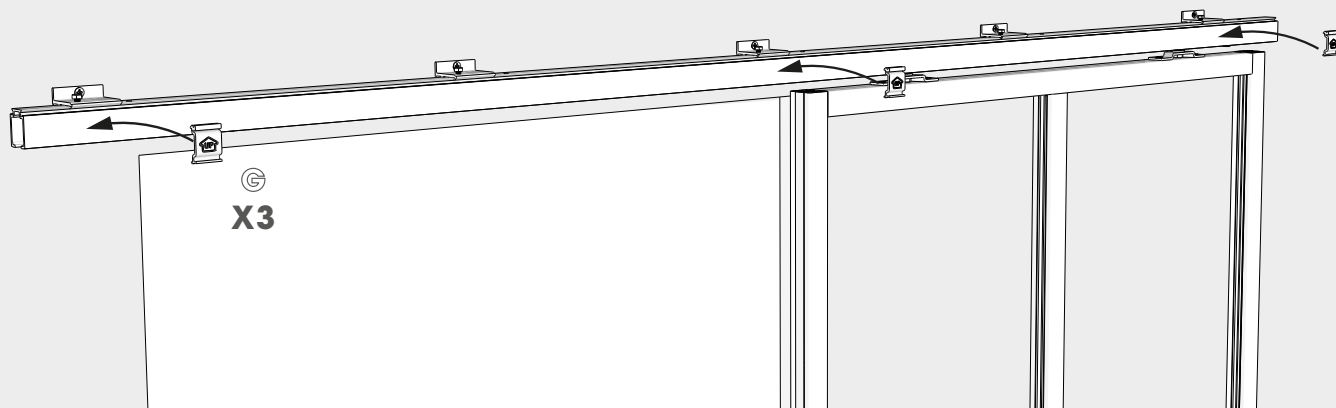

ÉTAPE 8 - STEP 8 - SCHRITT 8 - FÁZA 8 - KROK 8

A  
X1

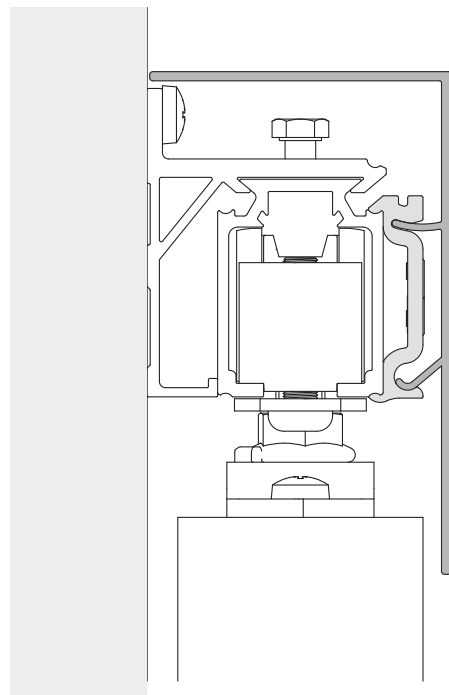
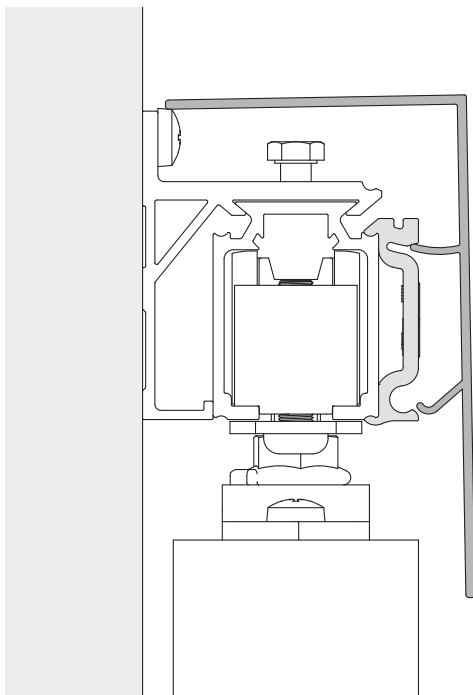
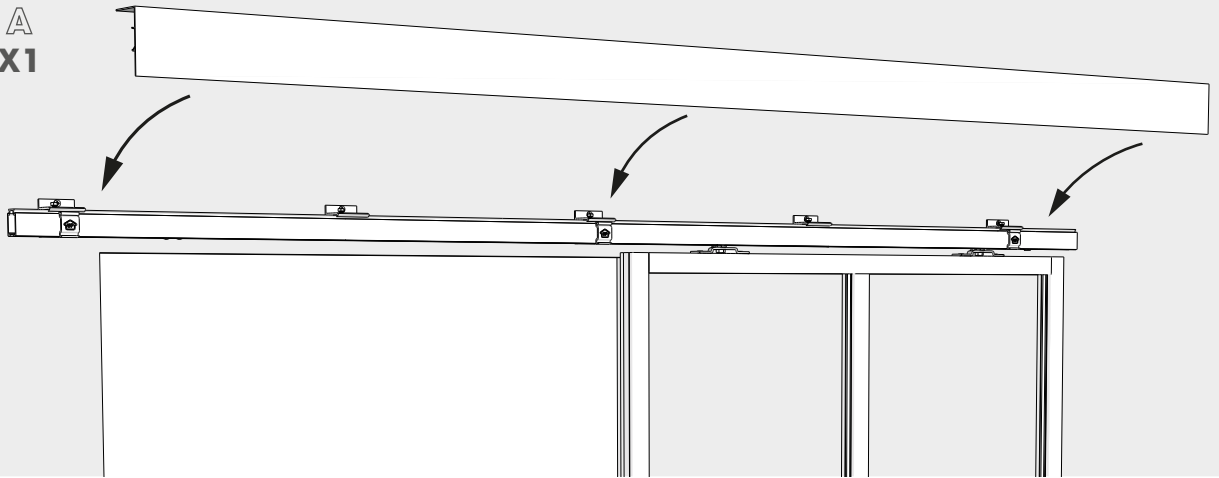

'clac'



# ÉTAPE 9 - STEP 9 - SCHRITT 9 - FÁZA 9 - KROK 9

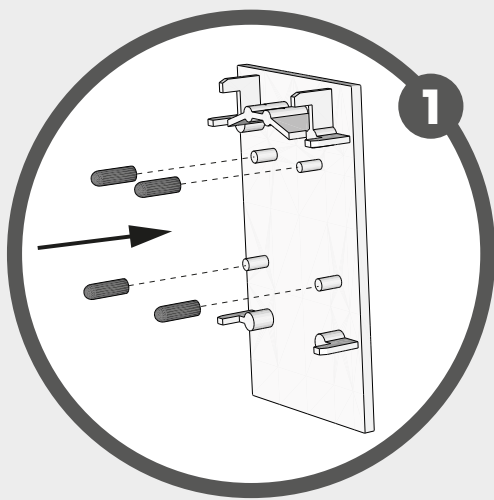

H  
X1

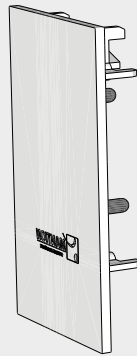

2

Répétez ces opérations pour le cache de droite.  
 Repeat these operations for the right side.  
 Wiederholen Sie die Vorgehensweise für die rechte Seite.  
 Tieto kroky zopakujte pre pravý kryt.  
 Zopakujte tyto kroky pro pravý kryt.

# ÉTAPE 10 - STEP 10 - SCHRITT 10 - FÁZA 10 - KROK 10

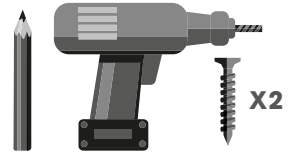

Porte en position ouverte  
 Door open position  
 Position der Tür offen  
 Dvere v otvorenej polohe  
 Dveře v otevřené poloze



1  
X1

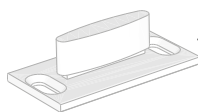

Porte en position fermée  
 Door closed position  
 Position der Tür geschlossen  
 Dvere v zatvorenej polohe  
 Dveře v zavřené poloze



2

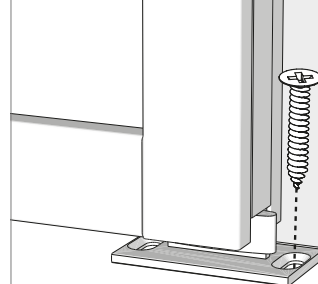

Fixation non fournie, à adapter à votre support.  
 Fixation (not provided) to adapt accordingly to your support.  
 Befestigungsmaterial ist nicht im Lieferumfang enthalten und muss separat erworben werden.  
 Upevňovacie prvky nie sú súčasťou dodávky, je potrebné ich prispôsobiť vašej podpore.  
 Upevňovací prvky nejsou součástí dodávky, je třeba je přizpůsobit vaší podpoře.

