

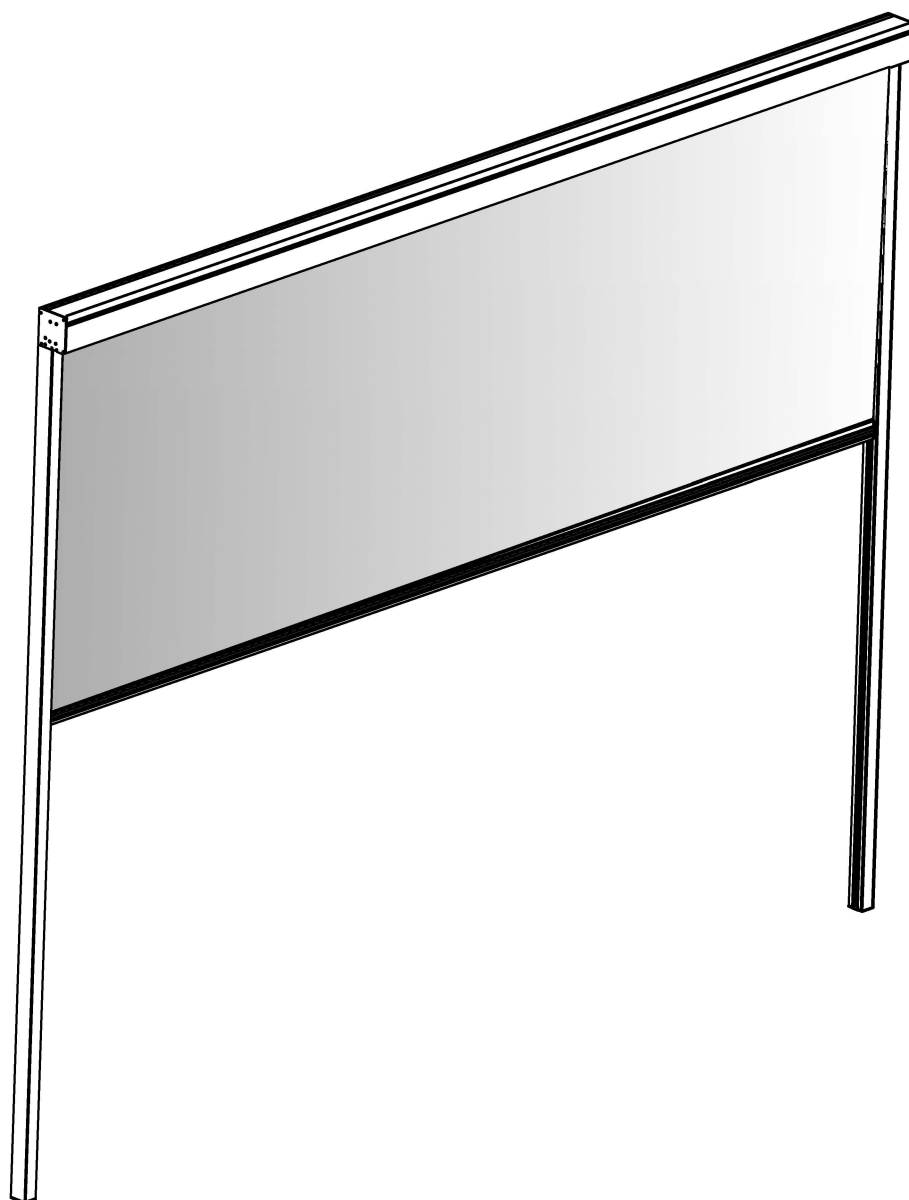







GFA32020P

BAHAG:31985453

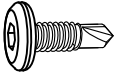

| | | | | |
|--|----|---|----|--|
| | | | | |
| | A |  | 1 | |
| | B1 |  | 1 | |
| | B2 |  | 1 | |
| | C |  | 1 | |
| | D |  M5*15 | 15 | |
| | E |  | 1 | |

DE: Halten Sie für den Aufbau bitte Folgendes bereit

BG: Моля, подгответе следните материали за монтажа

BA: Molimo pripremite sljedeće za montažu

CZ: Pro montáž si prosím připravte následující

DK: Hav venligst følgende klar til montering

ES: Prepárese para el ensamblaje

CA: Si us plau, tingueu el següent a punt per a l'assemblatge

EE: Kokkupanekuks on vaja

FI: Pidä seuraavat valmiina kokoamista varten

FR: S'il vous plaît, préparez les éléments suivants pour le montage

GB: Please have the following ready for assembly

HR: Za sastavljanje pripremite sljedeće

HU: Kérjük, készítse elő az alábbiakat az összeszereléshez

IS: Vinsamlega hafðu eftirfarandi tilbúið fyrir samsetningu

IT: Si prega di tenere pronto l'occorrente per l'assemblaggio

NO: Vennligst ha følgende klar for montering

RS: Пожалуйста, подготовьте следующее для сборки

SI: Pripravite naslednje stvari za montažo

SE: Ha följande redo att monteras

TR: Lütfen aşağıdakileri montaj için hazır bulundurun

NL: Houd het volgende gereed voor montage

SK: Na montáž si pripravte nasledovné

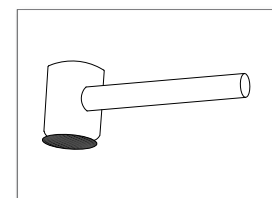
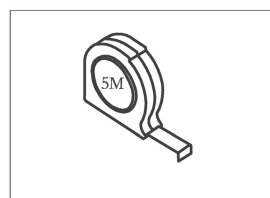
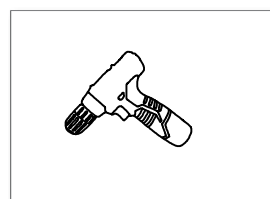
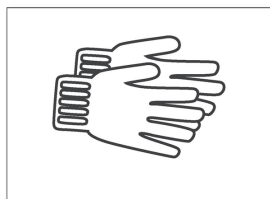

01

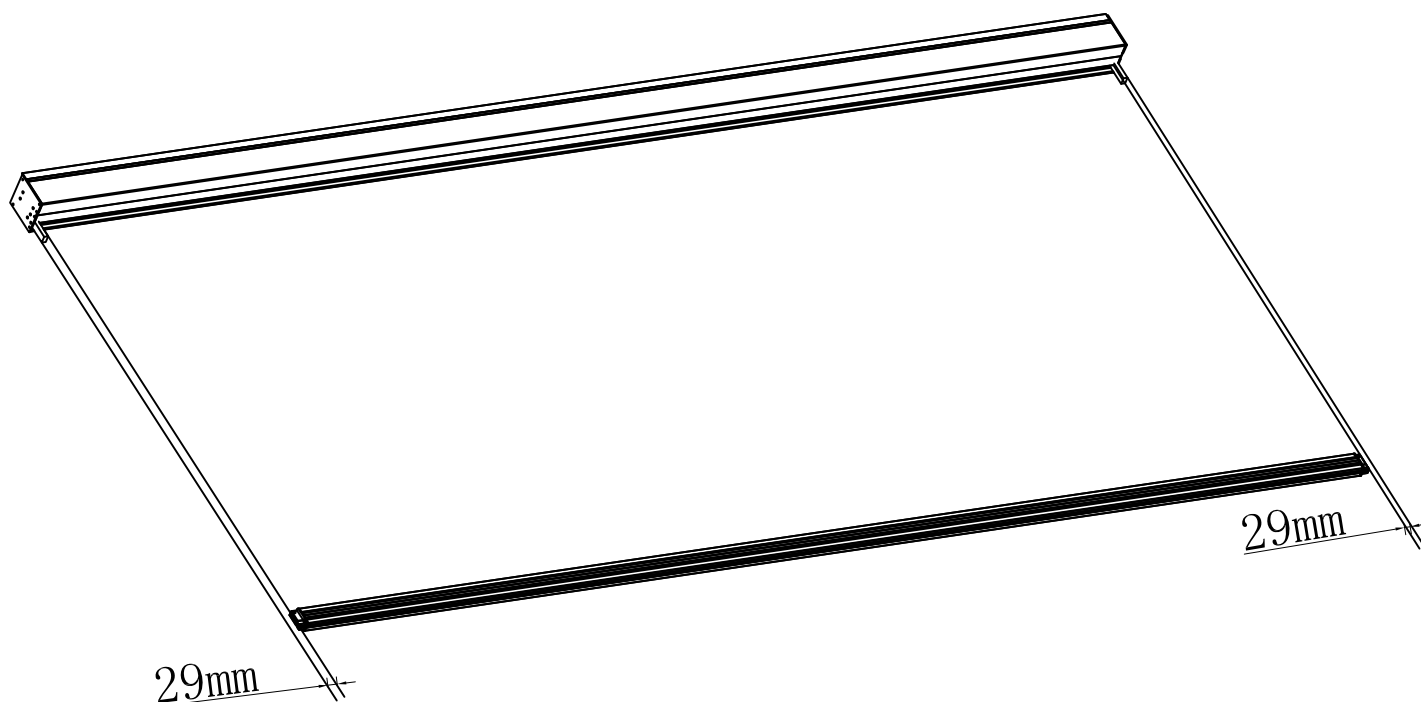
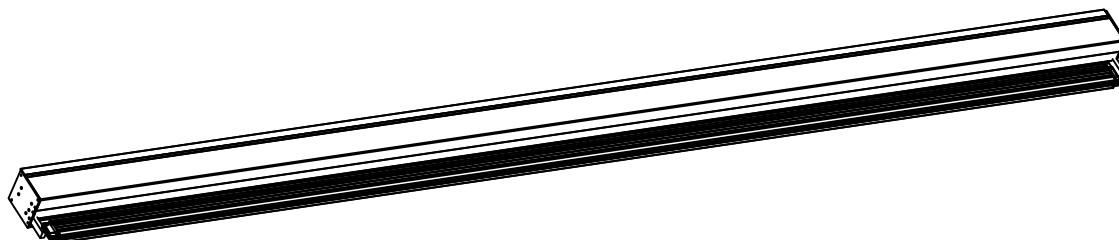

Ziehen Sie zunächst das Rollo heraus und prüfen Sie, ob der Abstand zwischen der Zugstange und der äußeren Endfläche 29 mm beträgt.

Um sicherzustellen, dass der Abstand zwischen den beiden Seiten des Stoffes gleich ist, müssen Sie einige weitere Züge wiederholen, bis er 29 mm erreicht.

Primero extraiga la persiana enrollable y compruebe que la distancia entre la varilla de tracción y la superficie del extremo exterior es de 29 mm.

Primer extregui la persiana enrol·lable i comprovi que la distància entre la vareta de tracció i la superfície de l'extrem exterior és de 29 mm.

02

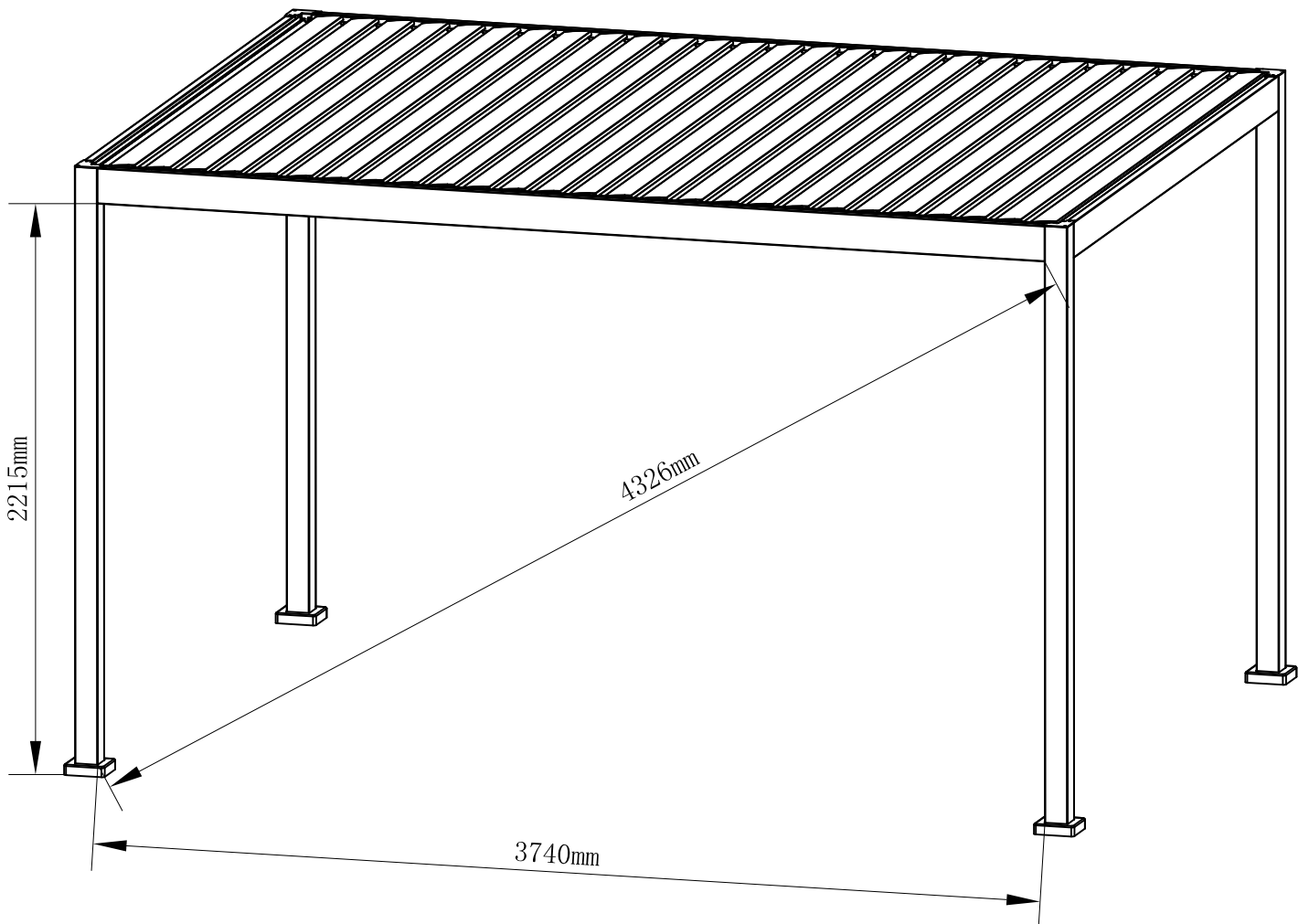

03

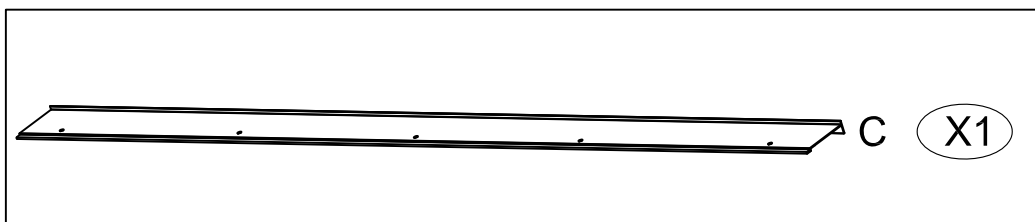
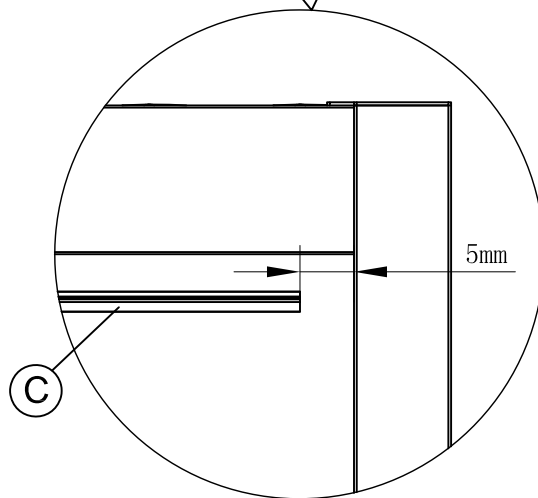
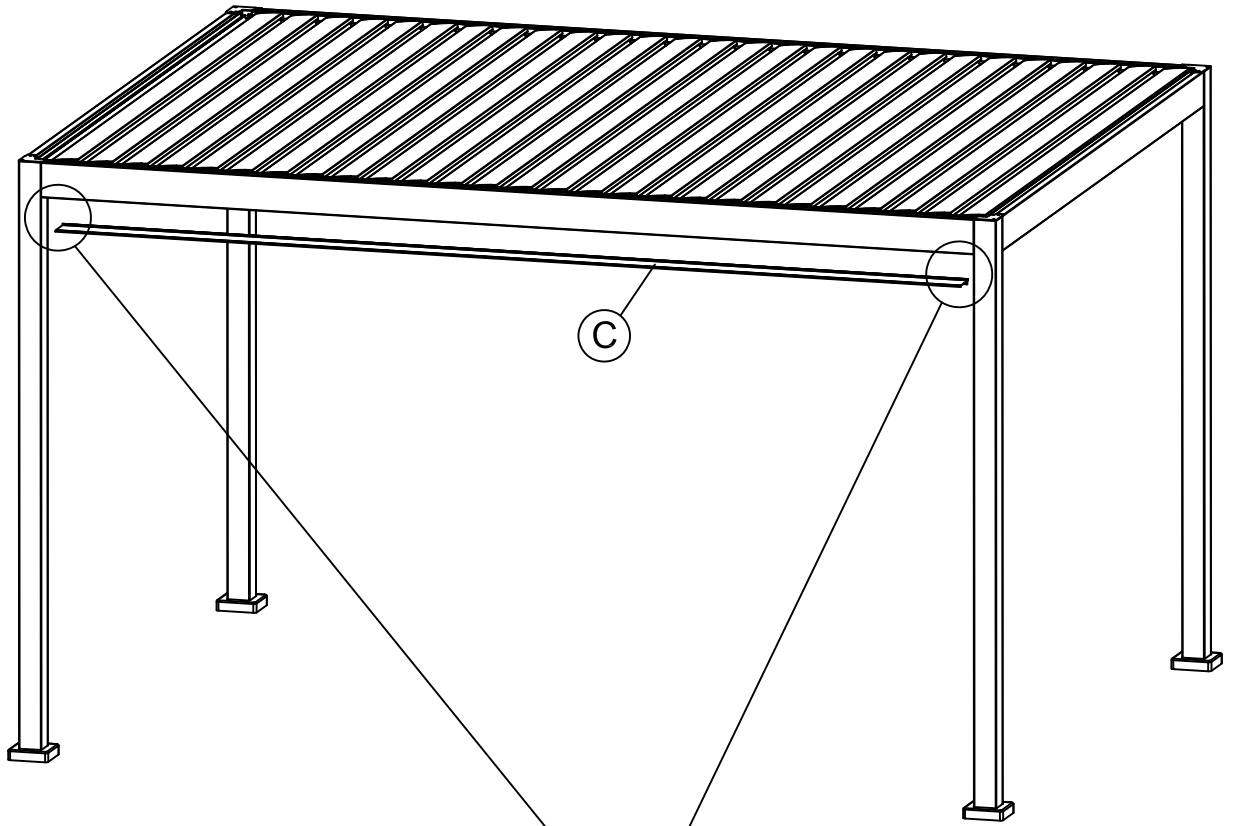

04

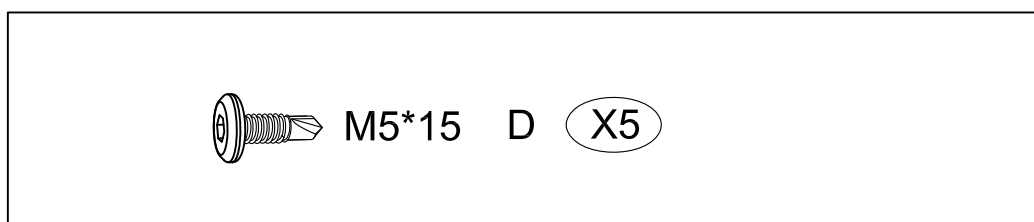
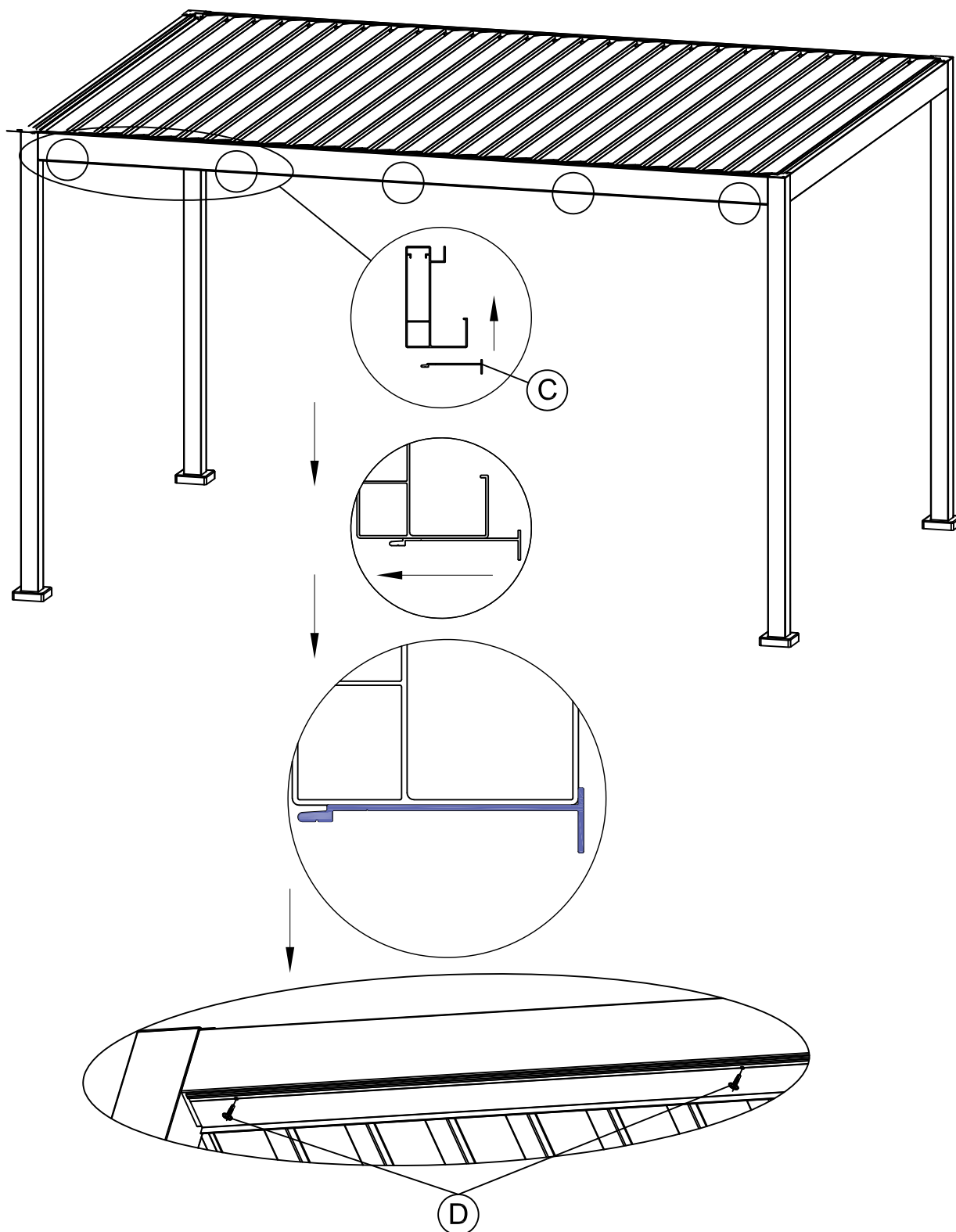

05

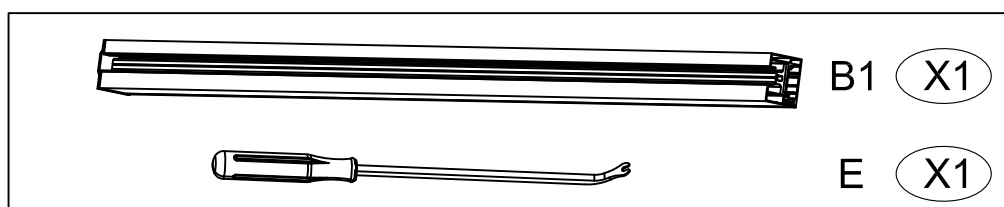
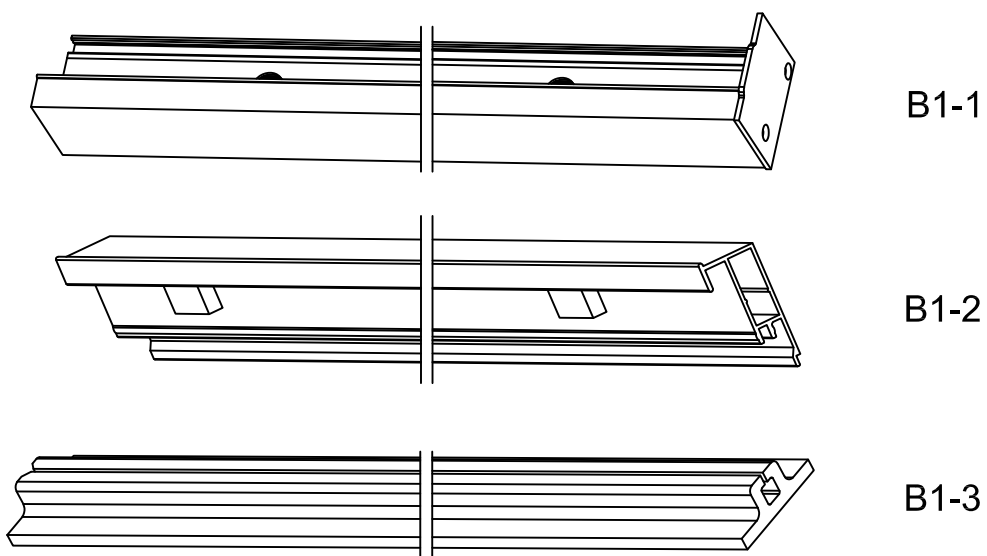
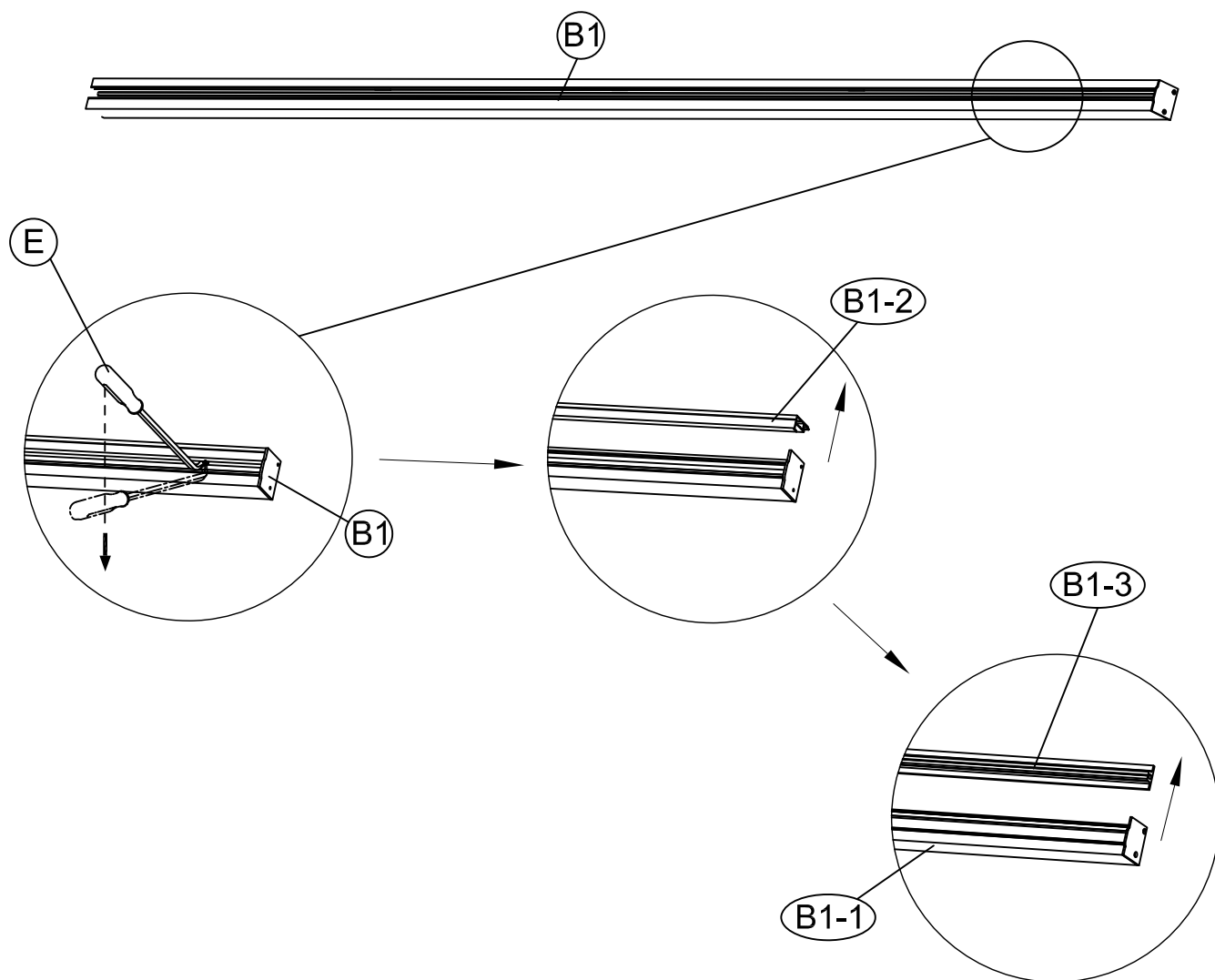

06

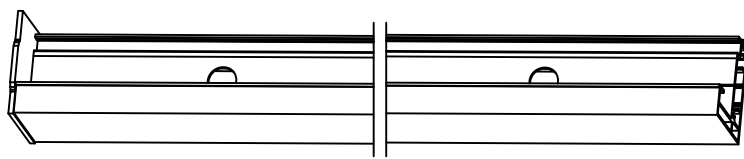
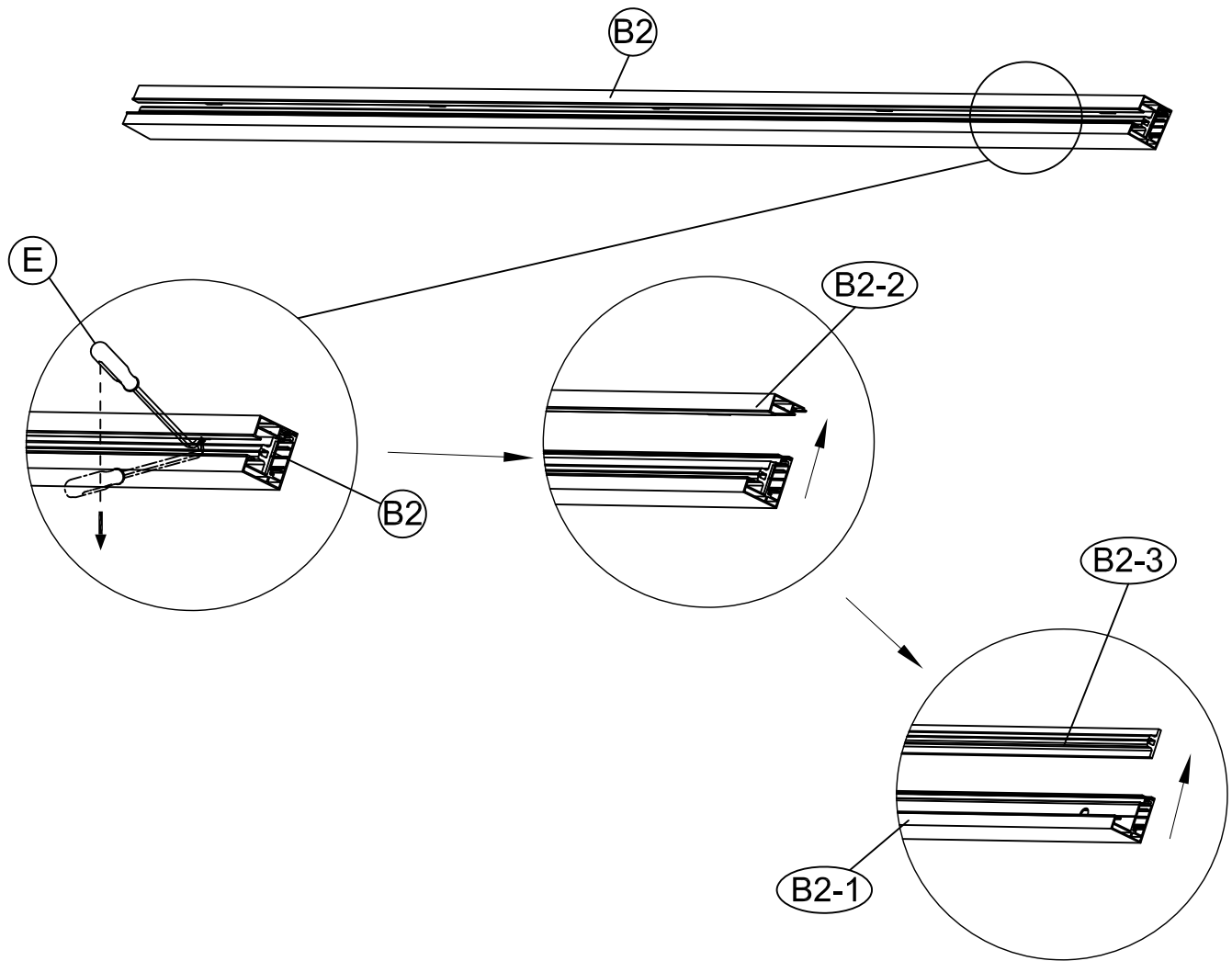

B2-1

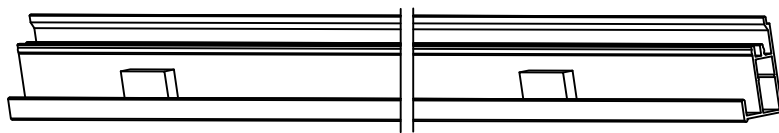

B2-2



B2-3

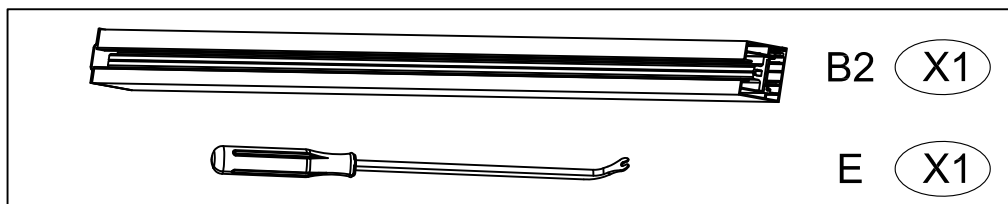

07

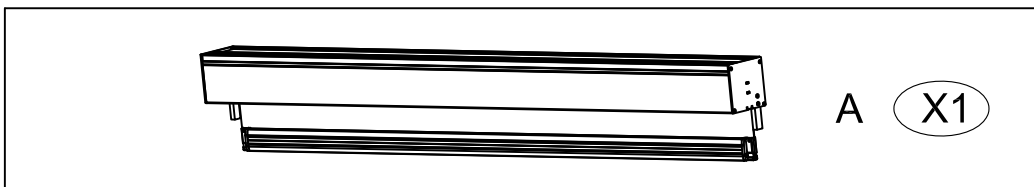
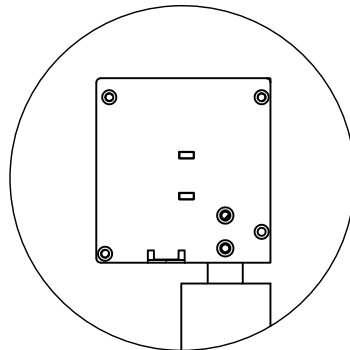
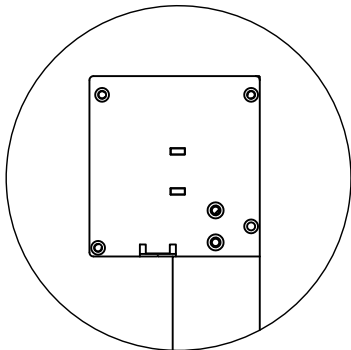
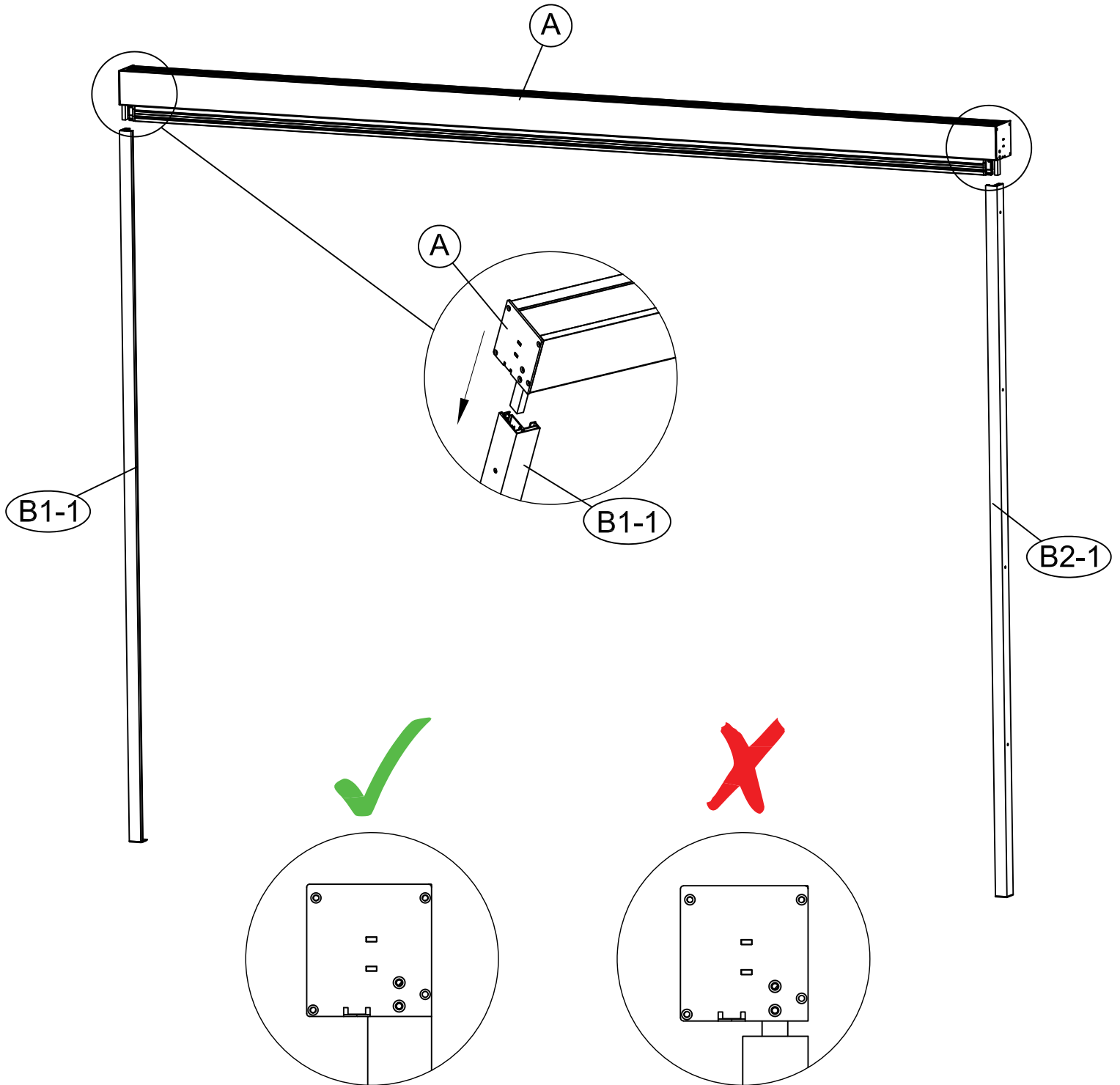

08

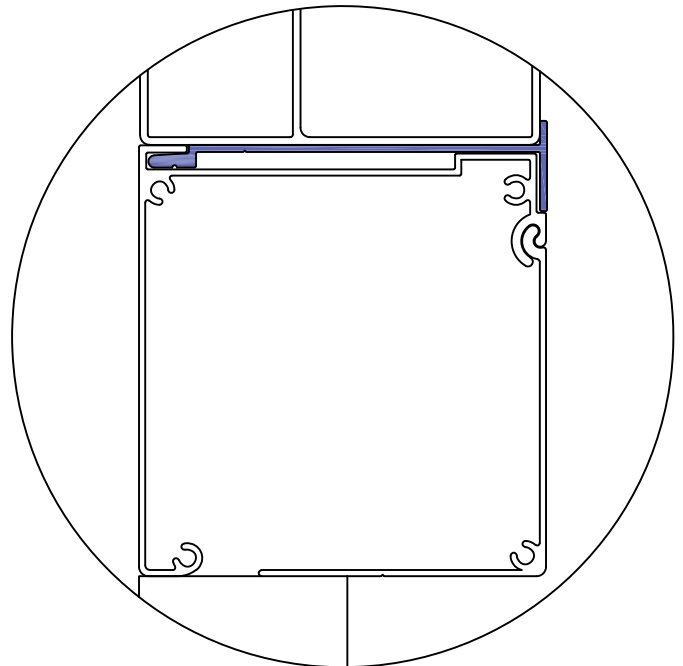
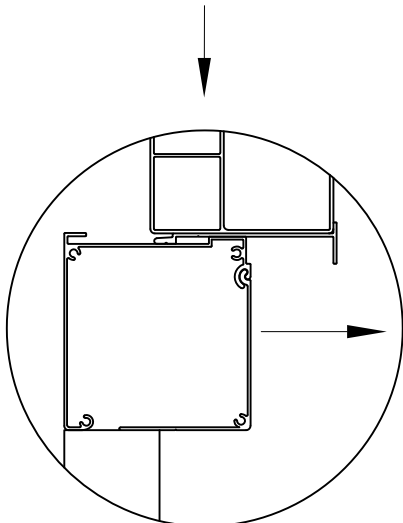
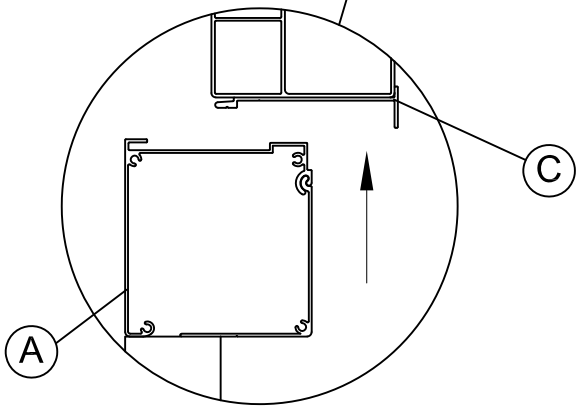
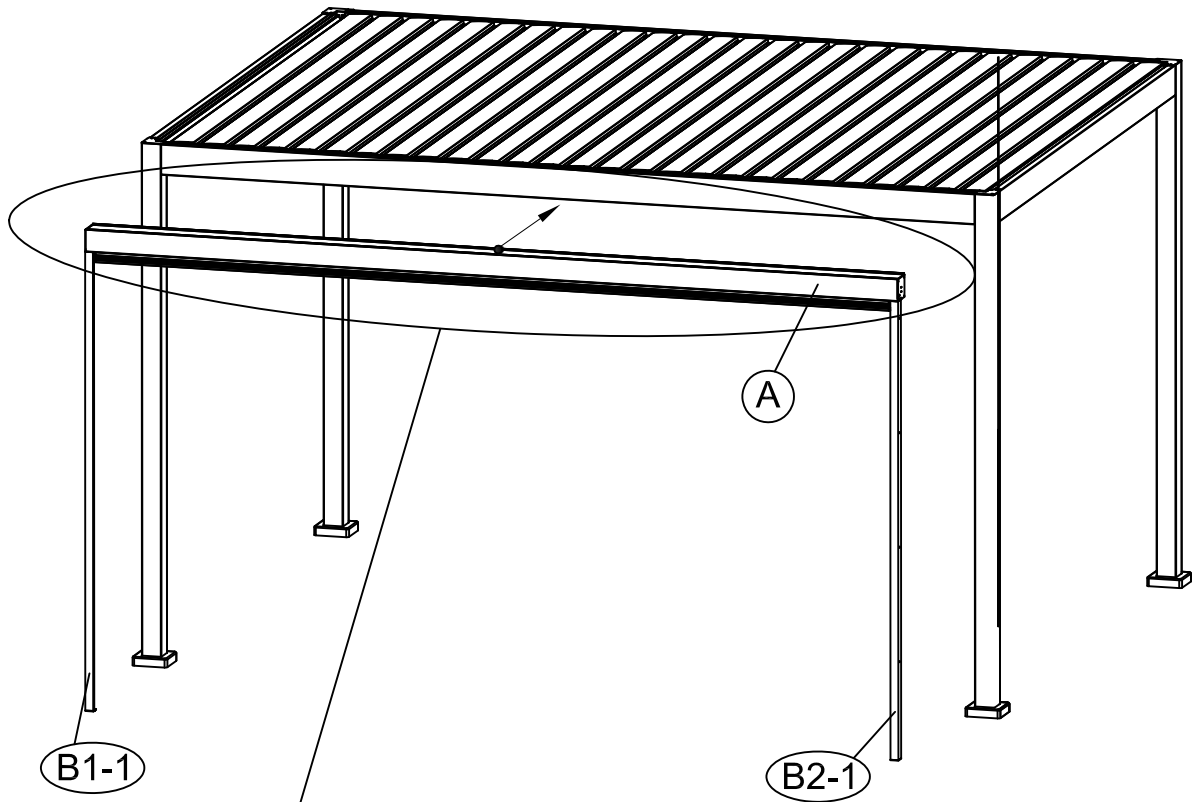

09

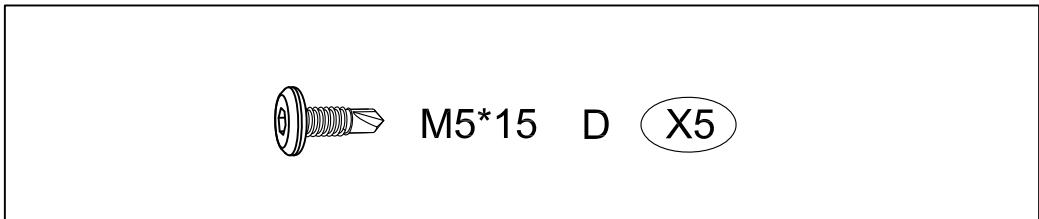
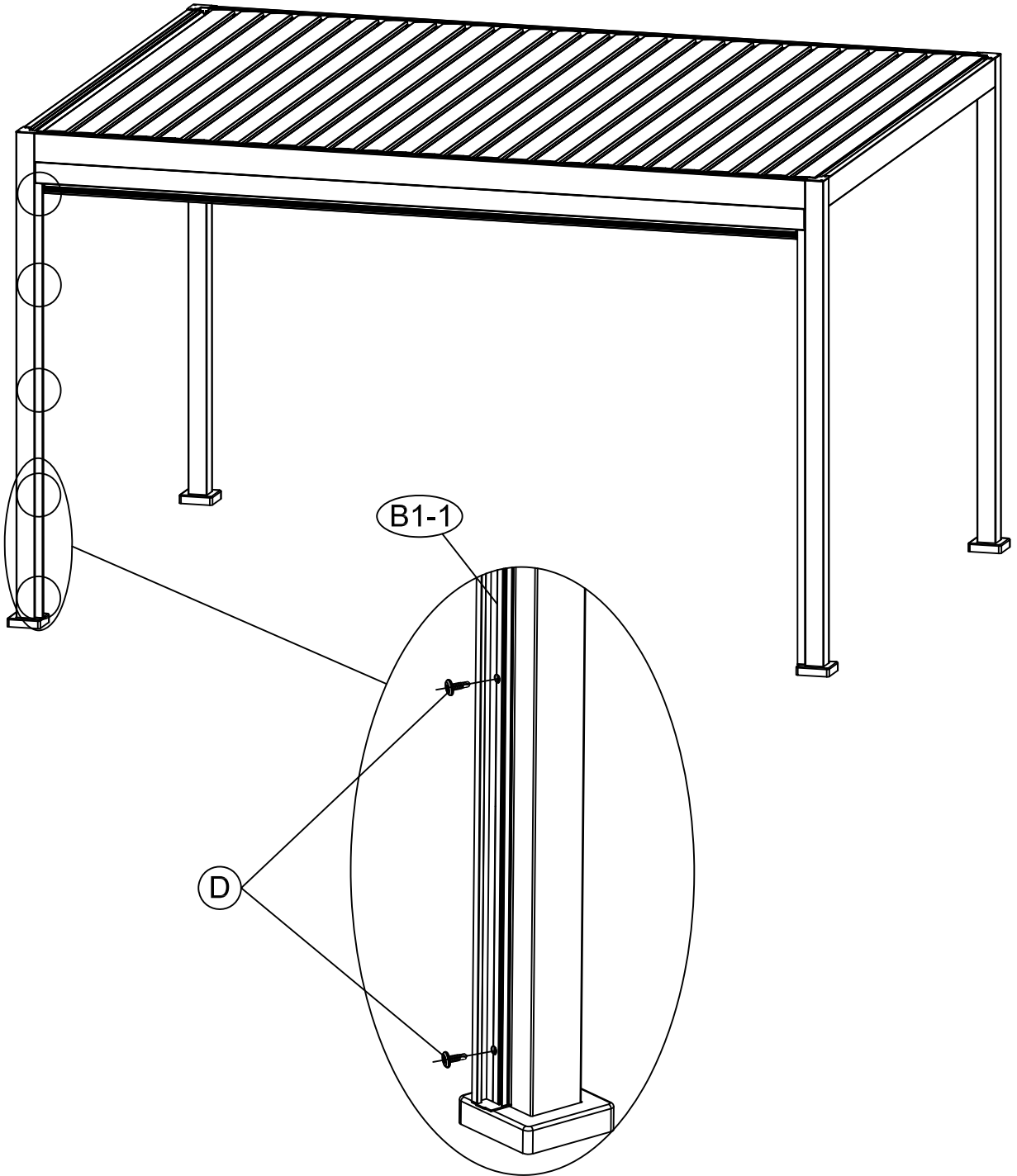

10

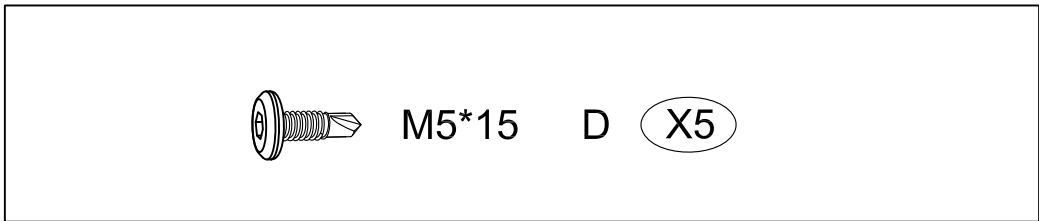
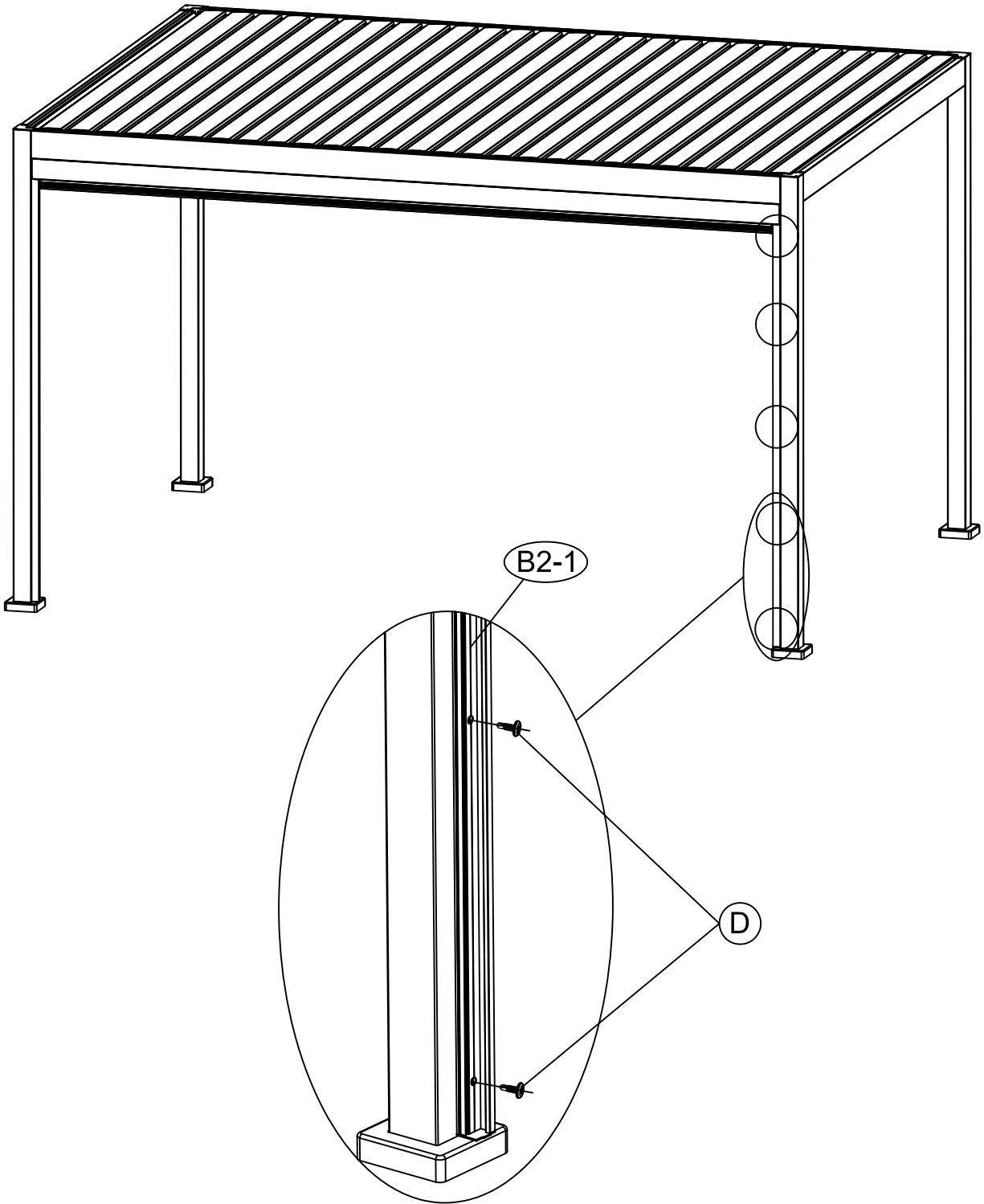

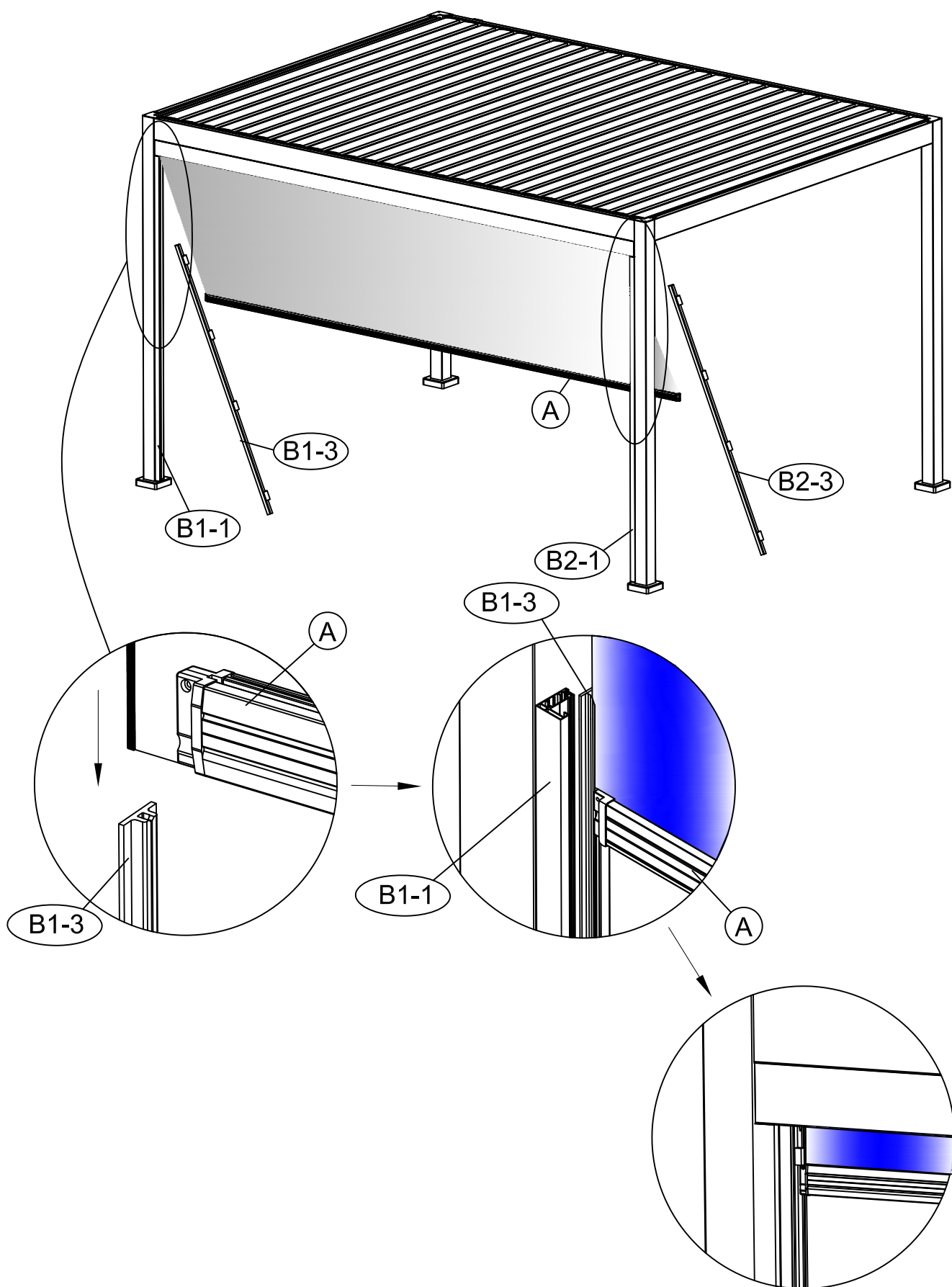

12

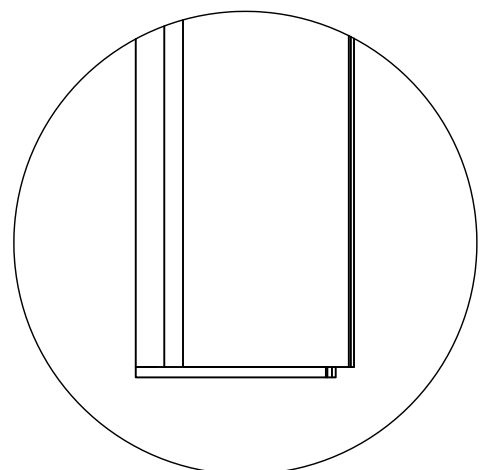
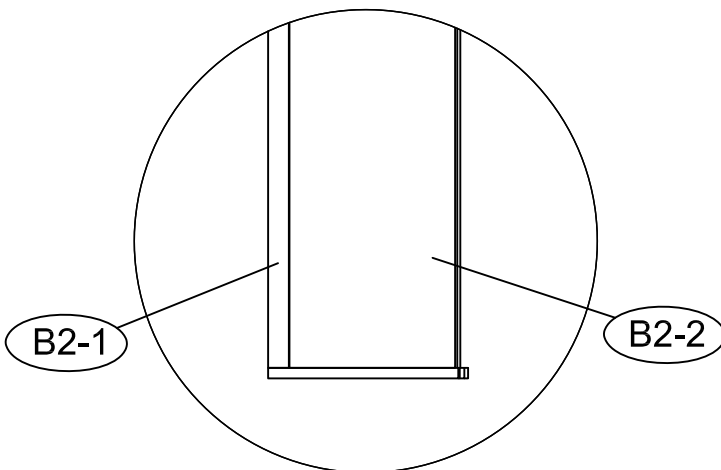
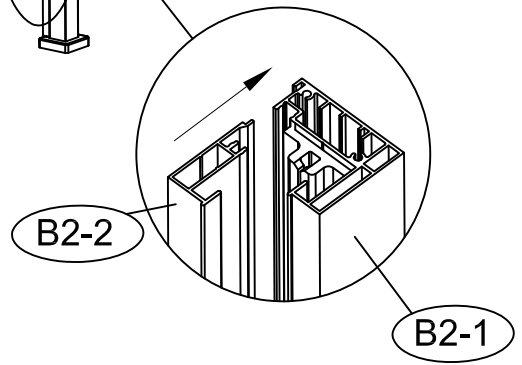
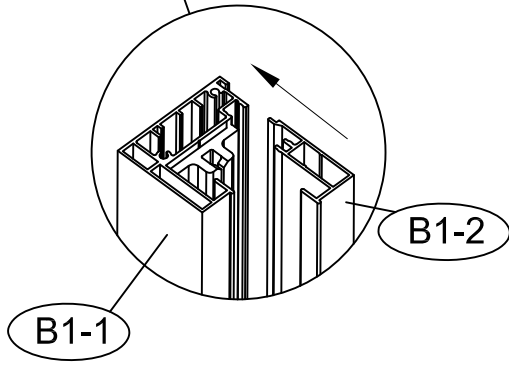
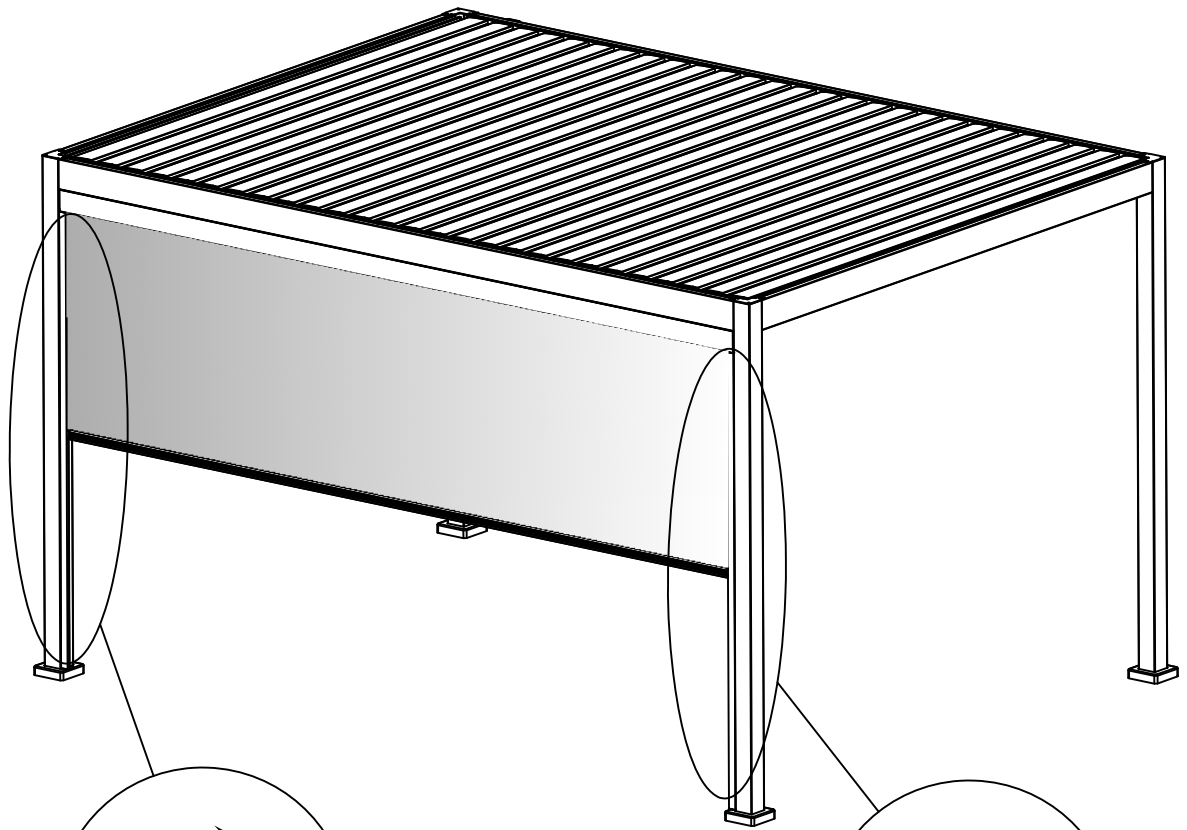

13

