

OTFEL10x8

V.12

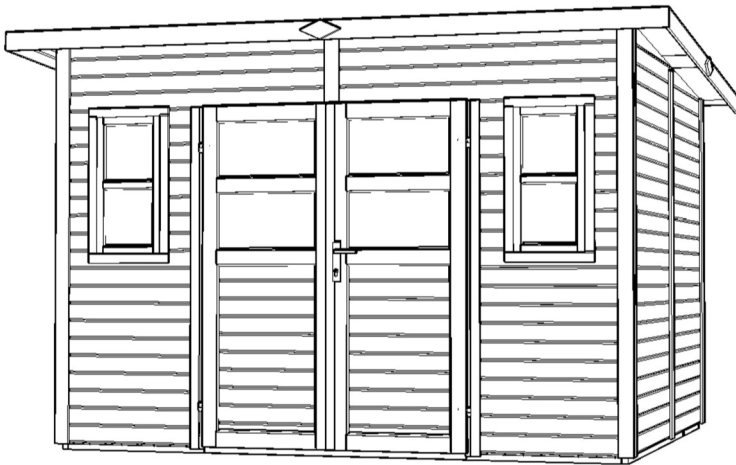

I

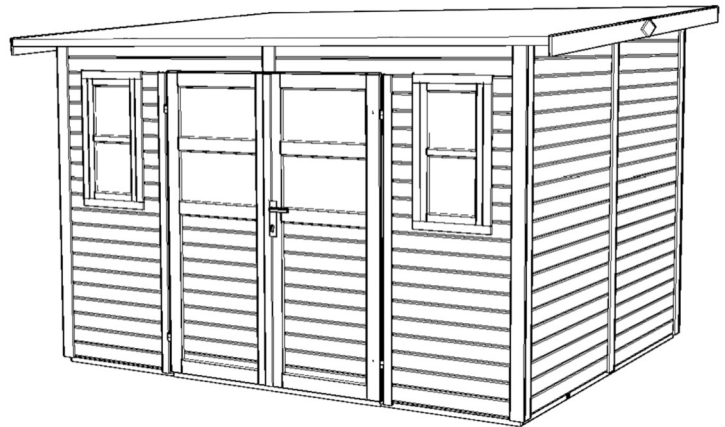

II

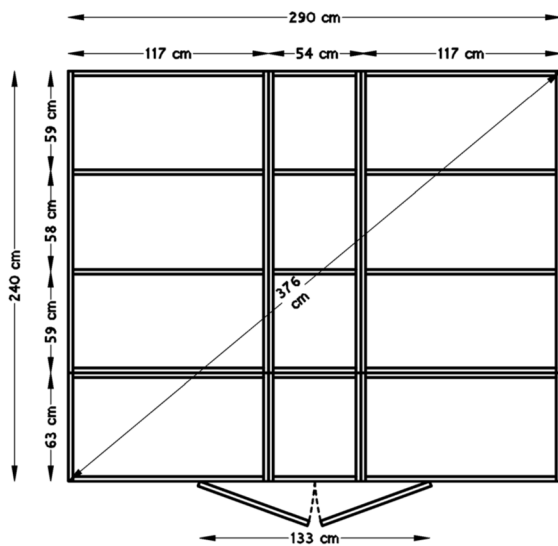

DE - Technische Änderungen vorbehalten.

Alle Maße sind ca. Maße.

EN - Technical modifications reserved.

All dimensions are approximate dimensions.



OTFEL10x8

DE Bevor Sie beginnen

• Es ist empfehlenswert sich etwas Zeit zu nehmen, um die Aufbauanleitung anzusehen, bevor mit dem Aufbau begonnen wird. • Alle Schritte für den Aufbau werden – auch in Detailbildern – dargestellt. • Die vorgegebene Reihenfolge ist zu beachten. • Bitte prüfen Sie vor dem Aufbau anhand der Teileliste die Vollständigkeit und den Zustand der Lieferung. • Besonders wichtig ist der Holzschutz! Die Boden-elemente sind vor dem Aufbau von unten mit einem geeigneten Holzschutz zu behandeln! • Das für die meisten Produkte online verfügbare Datenblatt bietet weitere wichtige Hinweise für den Aufbau. • Beigefügt sind auch die Garantiebedingungen.

FR Avant de commencer

• il est recommandé de prendre le temps de lire les instructions de montage avant de commencer. • Toutes les étapes du montage sont présentées, y compris sur des illustrations détaillées. • L'ordre prescrit doit être respecté. • Avant le montage, vérifiez l'exhaustivité et l'état de la livraison à l'aide de la liste des pièces. • La protection du bois est particulièrement importante! Avant le montage, les éléments de plancher doivent être traités par le bas avec un produit de protection du bois approprié! • La fiche technique disponible en ligne pour la plupart des produits fournit d'autres informations importantes pour le montage. • Les conditions de garantie y sont également jointes.

CZ Než začnete

• Doporučujeme, abyste si vzali trochu času k prohlédnutí montážního návodu, než s montáží začnete. • Všechny montážní kroky jsou zobrazeny - také na podrobných obrázcích. • Je nutné dodržovat uvedený postup. • Před montáží zkontrolujte podle seznamu dílů, zda jste obdrželi všechny díly a zda je dodávka v dobrém stavu. • Obzvláště důležitá je dřevěná botka! Podlahové prvky musí být před montáží zespoda ošetřeny vhodným ochranným přípravkem na dřevo! • Datový list, který je k dispozici online pro většinu produktů, poskytuje další důležité pokyny k montáži. • V příloze naleznete také záruční podmínky.

DK Før du starter

• Det kan anbefales at tage sig tid til at kigge på samlevejledningen, før du starter samlingen. • Alle trin i samlingen bliver vist – også i detaljerede billeder. • Overhold den angivne rækkefølge. • Kontrollér, at leveringen er fuldstændig og i den rette tilstand ved hjælp af delelisten, før du starter samlingen. • Særligt vigtig er træbeskyttelsen! Gulvelementerne skal behandles med egnet træbeskyttelse nedefra, før du starter samlingen! • Til de fleste produkter kan du finde datablade online, der indeholder yderligere vigtige informationer til samlingen. • Garantibetingelserne er også vedlagt.

NL Voordat u begint

• Het is aan te bevelen om de tijd te nemen om de opbouwhandleiding door te nemen voordat er met het opbouwen wordt begonnen. • Alle stappen voor het opbouwen worden - ook met gedetailleerde afbeeldingen - weergegeven. • Neem de aangegeven volgorde in acht. • Controleer voor het opbouwen aan de hand van de onderdelenlijst de volledigheid en de hoedanigheid van de levering. • Bijzonder belangrijk is de bescherming van het hout! De vloerelementen moeten voor het opbouwen van onderen met een geschikt houtbeschermingsmiddel worden behandeld! • Het voor de meeste producten online beschikbare gegevensblad bevat verdere belangrijke aanwijzingen voor de opbouw. • Bijgevoegd zijn ook de garantiebepalingen.

PL Przed rozpoczęciem

• Wskazane jest, aby przed przystąpieniem do montażu zapoznać się z instrukcją montażu. • Pokazane są wszystkie etapy montażu – również na szczegółowych zdjęciach. • Należy przestrzegać podanej kolejności. • Przed montażem należy skorzystać z listy części, aby sprawdzić, czy dostawa jest kompletna i w dobrym stanie. • Ochrona drewna jest szczególnie ważna! Przed montażem elementy podłogowe należy zabezpieczyć od dołu odpowiednim środkiem do konserwacji drewna! • Arkusz danych, który jest dostępny online dla większości produktów, zawiera dalsze ważne informacje dotyczące montażu. • Załączone są również warunki gwarancji.

SV Innan du börjar

• Vi rekommenderar att du åsidosätter lite tid för att titta igenom monteringsanvisningen innan du påbörjar monteringen. • Alla monteringsstegen visas – även med detaljerade bilder. • Den angivna ordningen måste följas. • Kontrollera att leveransen är komplett och i gott skick innan monteringen påbörjas med hjälp av listan över delar. • Träskyddet är av yttersta vikt! Golvelementen ska behandlas underifrån med lämpligt träskyddsmedel före monteringen! • Annan viktig information före montering finns i databladet (tillgängligt online för de flesta produkter). • Garantivillkoren bifogas också.

RO Înainte să începeți

• Vă recomandăm să dedicați puțin timp pentru a consulta Instrucțiunile de asamblare înainte de a începe asamblarea. • Toate etapele de asamblare sunt prezentate amănunțit - și în forma unor figuri detaliate. • Respectați ordinea specificată. • Înainte de asamblare, vă rugăm să verificați lista de componente pentru a vă asigura că furnitura este completă și în stare bună. • Acordați o deosebită atenție protecției lemnului! Elementele de podea trebuie tratate de dedesubt cu o substanță conservantă adecvată pentru protecția lemnului înainte de asamblare! • Fișa de date, care este disponibilă și online pentru majoritatea produselor, oferă informații suplimentare importante cu privire la asamblare. • Atașat veți găsi și condițiile de garanție.

EE Soovitused enne paigalduse alustamist

• Soovitame enne paigalduse alustamist võtta aega ja tutvuda paigaldusjuhendiga. • Kõik kokkupaneku etapid on näidatud ka üksikasjalikel piltidel. • Paigaldustööd tuleks teha etteantud järjekorras. • Enne paigalduse alustamist kontrollige detailide nimekirja alusel, kas kõik elemendid on olemas ja ega need pole kahjustada saanud. • Puidukaitse on eriti oluline! Põrandaelemente tuleb enne kokkupanekut töödelda altpoolt sobiva puidukaitsevahendiga! • Andmeleht, mis on enamiku toodete kohta internetis saadaval, pakub kokkupanekuks täiendavat olulist teavet. • Lisatud on ka garantiitingimused.

EN Before assembly

• We recommend that time is taken to read the assembly instructions prior to assembly. • All assembly steps are shown – also in detailed images. • The step-by-step instructions must be followed. • Before assembly, please use the parts list to check that all components are accounted for and in good condition. • Wood protection is particularly important! The floor elements must be treated from below with a suitable wood preservative before assembly! • The data sheet, which is available online for most products, offers further important information for assembly. • The guarantee conditions are also attached.

OTFEL10x8

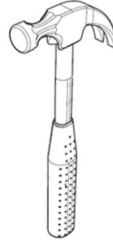
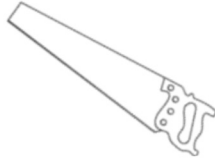
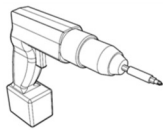

Ø 4 mm

Ø 8 mm

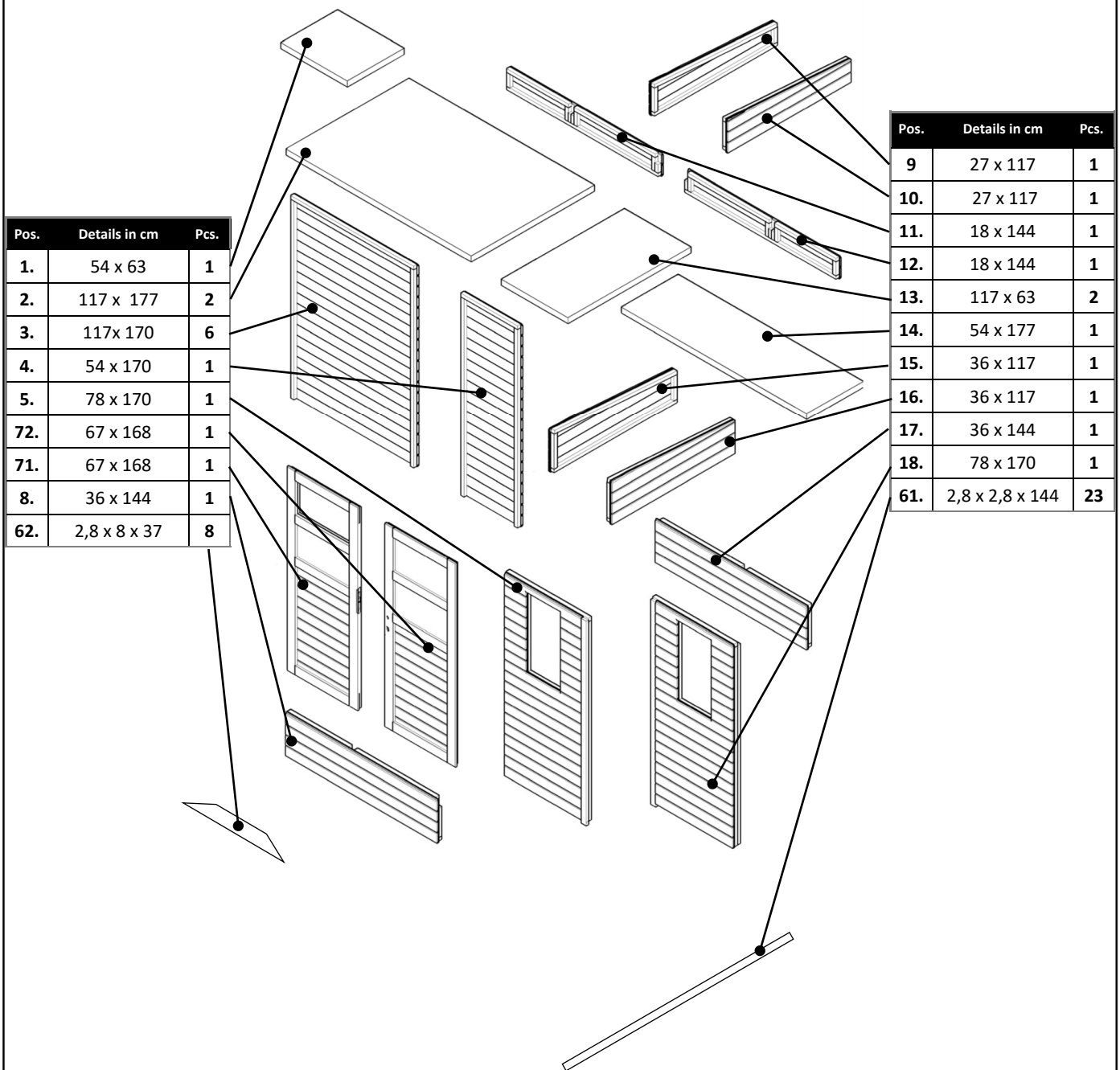
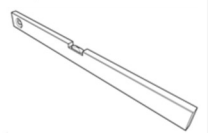

OTFEL10x8

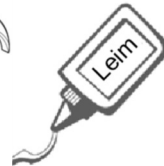
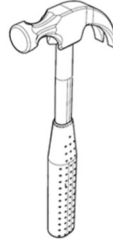
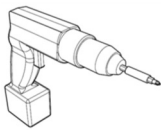

Ø 4 mm

Ø 8 mm

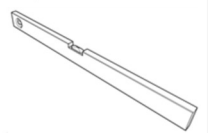

Pos.	Details in cm	Pcs.
19.	2,8 x 2,8 x 135	4
20.	46 x 83	4
21.	2,8 x 2,8 x 166	4
22.	83 x 115	8
23.	35 x 69	2
24.	1,2 x 4,2 x 43	4
25.	1,2 x 4,2 x 69	4
26.	1,2 x 4,2 x 168	3
27.	28 x 30	4
28.	29 x 53	4
29.	1,9 x 4,5 x 133	1
30.	2,8 x 2,8 x 133	1
31.	1,5 x 1,5 x 53	8
32.	2,8 x 8 x 63	6

Pos.	Details in cm	Pcs.
33.	1,2 x 9 x 138	4
34.	2,8 x 8 x 17	2
35.	1,2 x 9 x 168	2
36.	1,2 x 7 x 168	12
37.	1,2 x 7 x 36	7
38.	1,5 x 1,5 x 27	8
39.	1,2 x 7 x 18	6
40.	1,9 x 4,5 x 168	4
41.	1,9 x 4,5 x 56	4
42.	1,9 x 4,5 x 77	4
43.	1,9 x 4,5 x 36	2
44.	1,9 x 4,5 x 18	2
45.	2,8 x 8 x 177	10
46.	1,2 x 9 x 20	3
48.	1,5 x 1,5 x 28	8
49.	1,5 x 1,5 x 29	8

60.
Ø4,5x90mm
5 Pcs

50.
1 Pcs

51.
2 Pcs

59.
Ø4,5x75mm
32 Pcs



58.
Ø4,5x50mm
250 Pcs

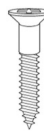

57.
Ø3,5x35mm
390 Pcs



56.
Ø4x25mm
48 Pcs



55.
Ø1,4x25mm
76 Pcs



53.
4 Pcs

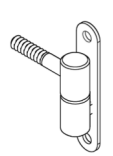

52.
1 Pcs

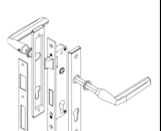

OTFEL10x8

1.

7X

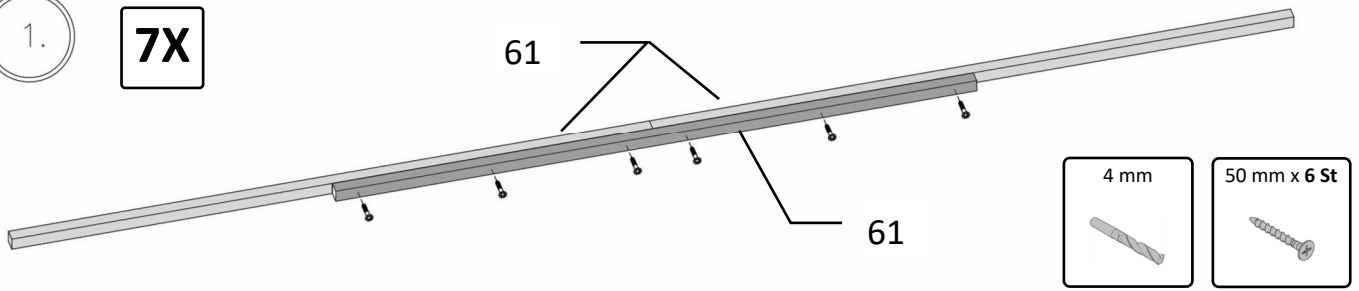

2.

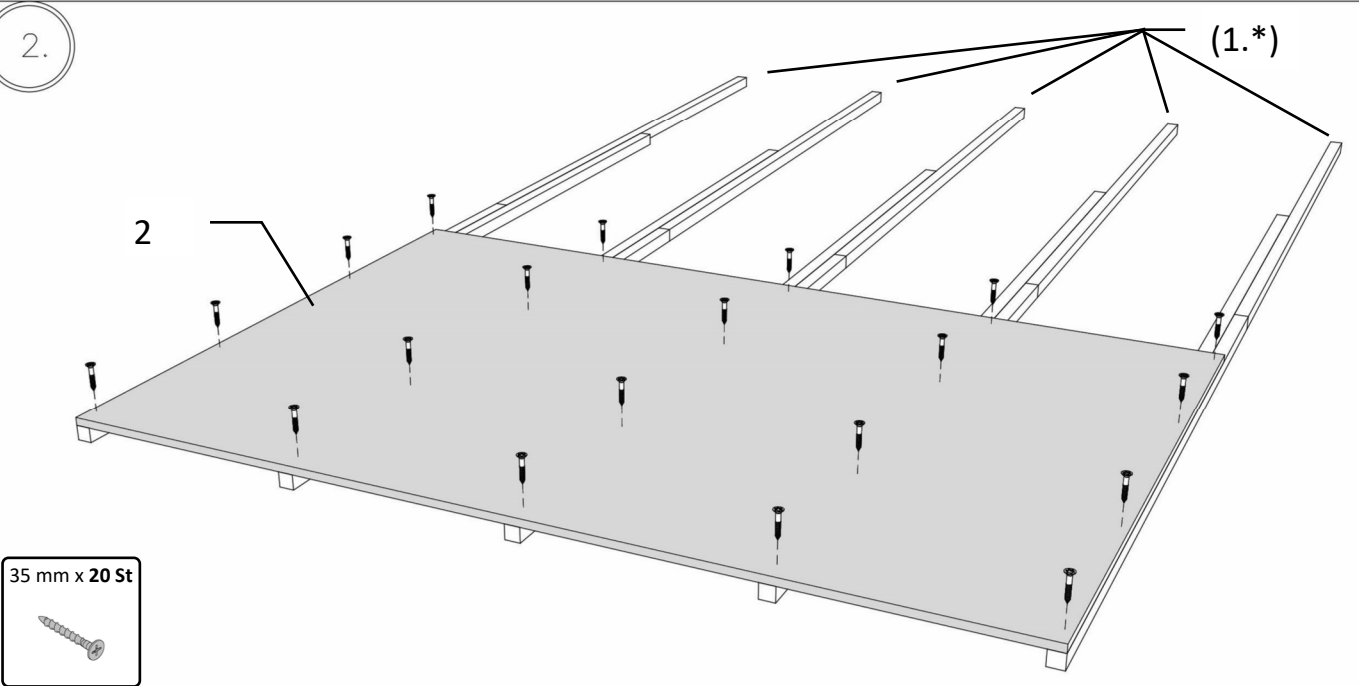

3.

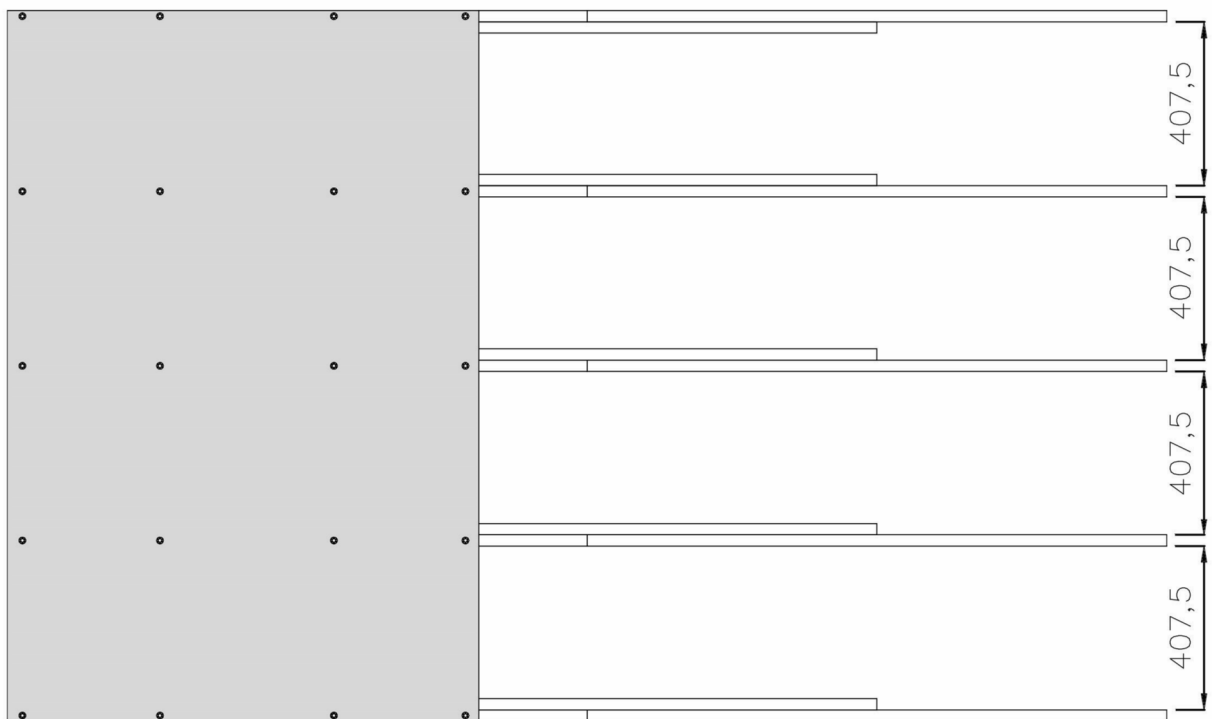

OTFEL10x8

4.

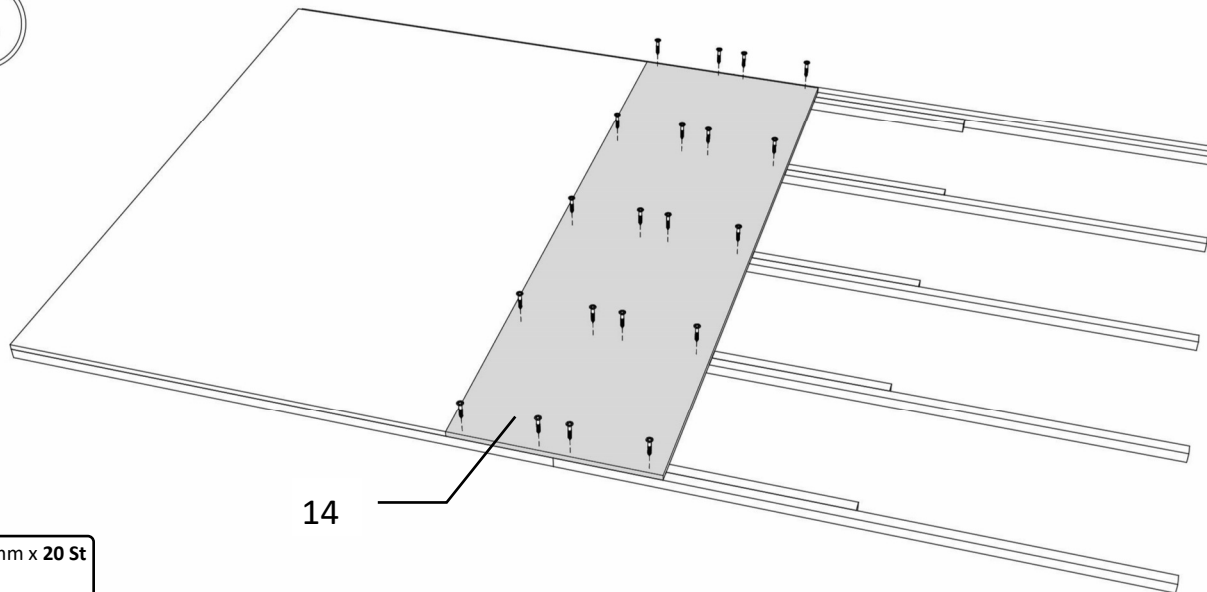

14

35 mm x 20 St



5.

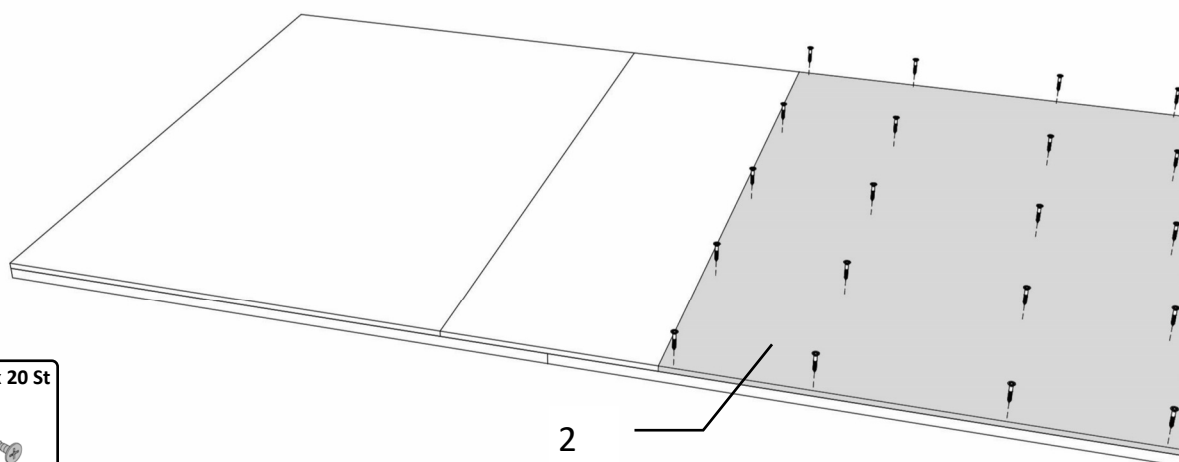

2

35 mm x 20 St



6.

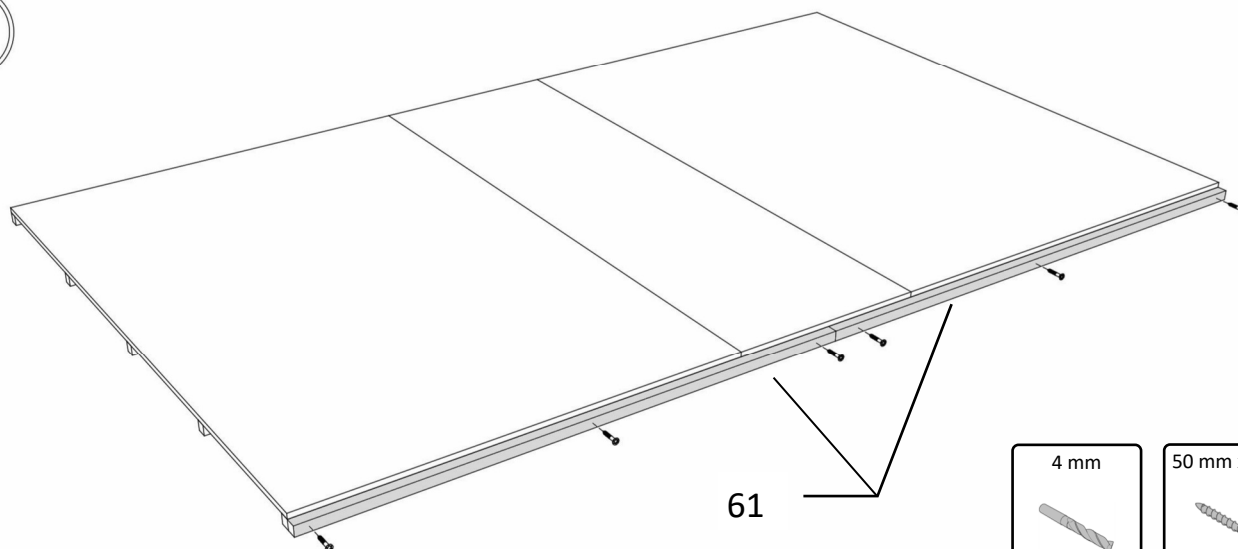

61

4 mm



50 mm x 6 St



OTFEL10x8

8.

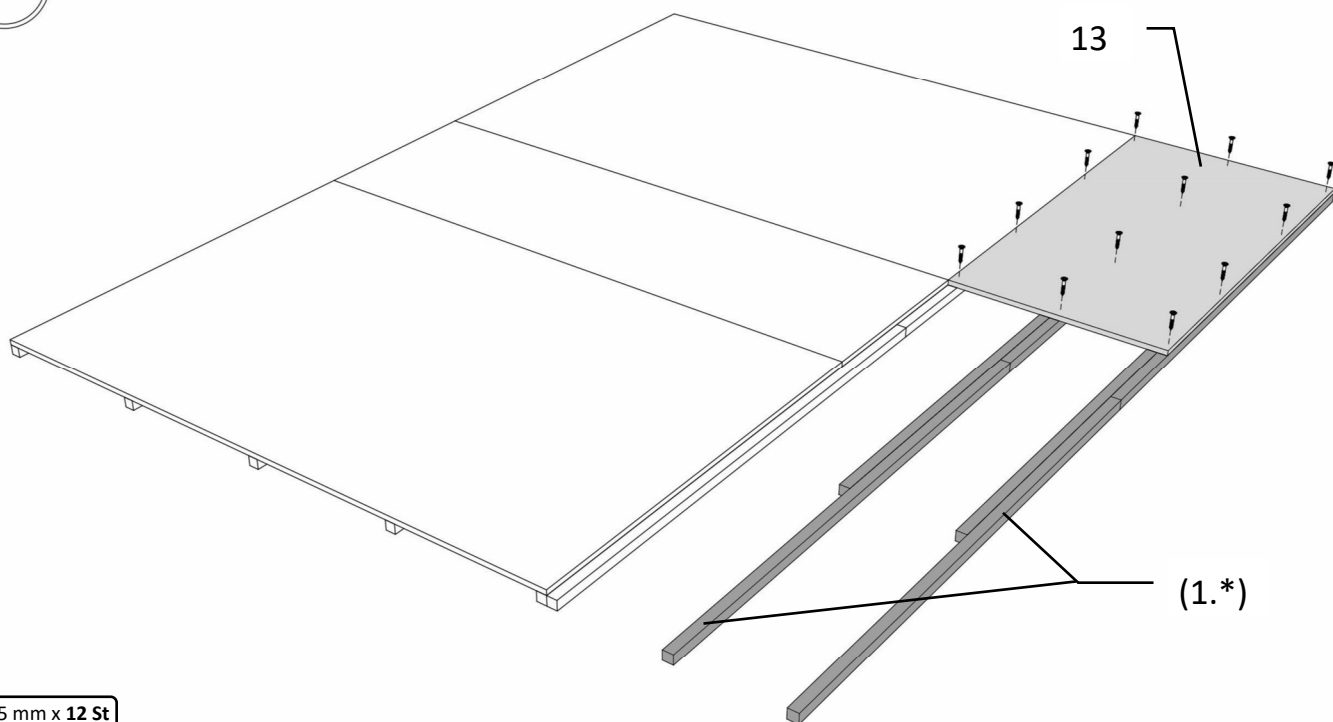

35 mm x 12 St



9.

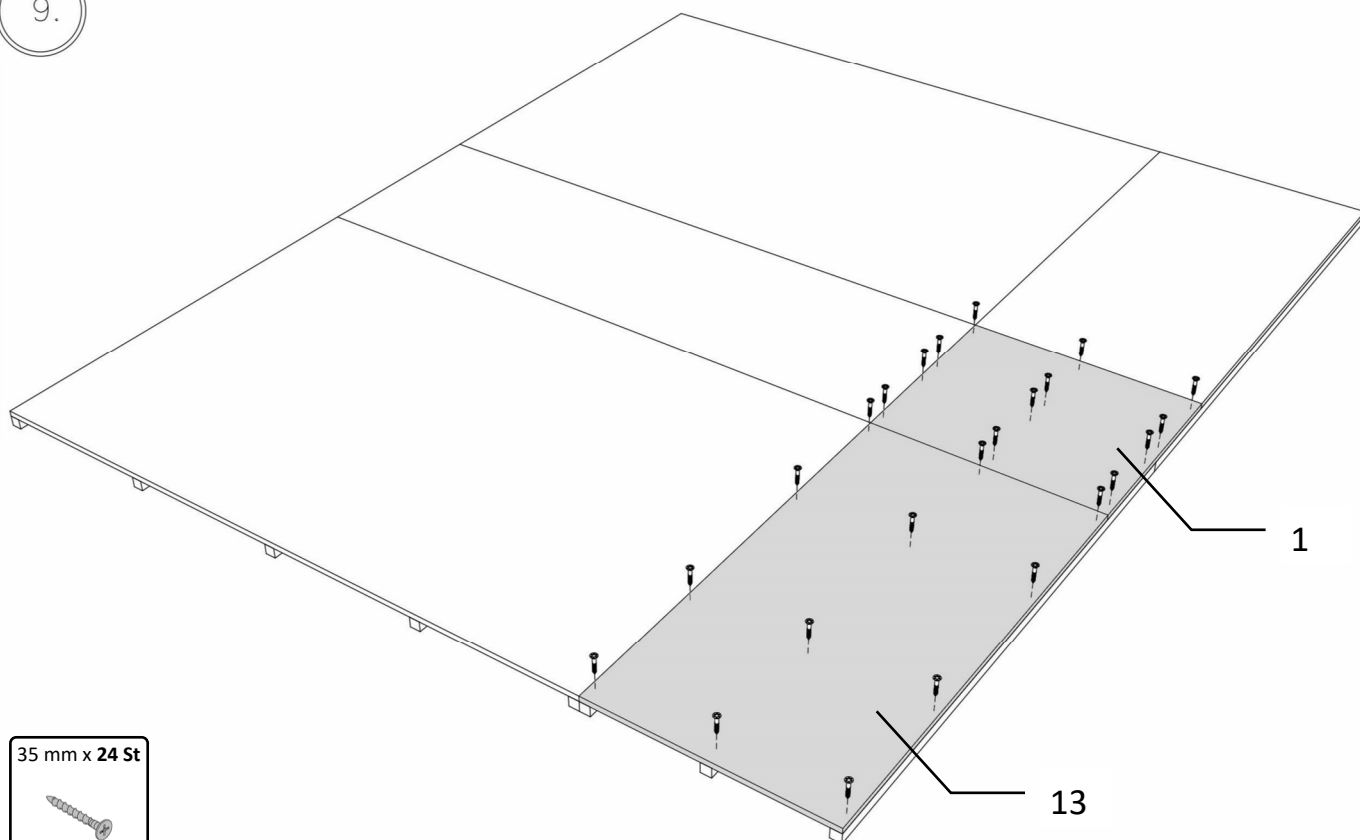

35 mm x 24 St



OTFEL10x8

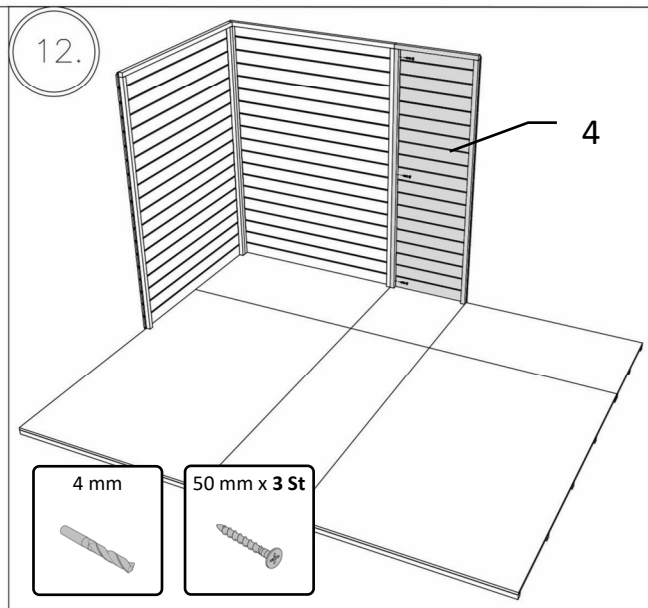
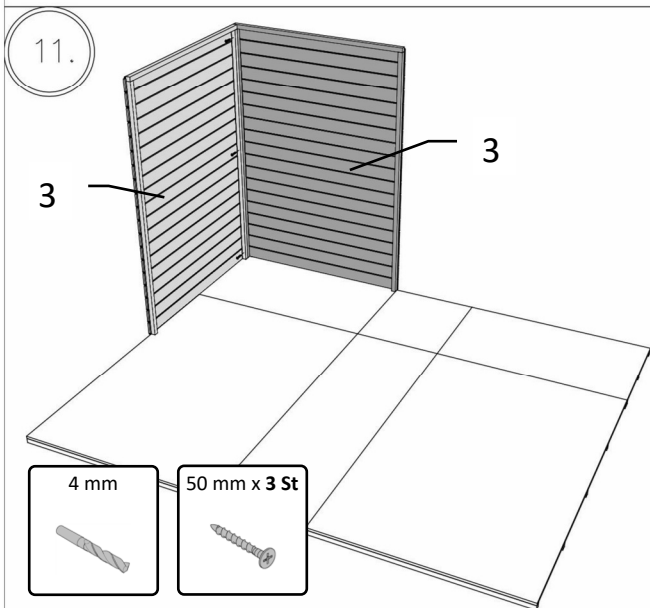
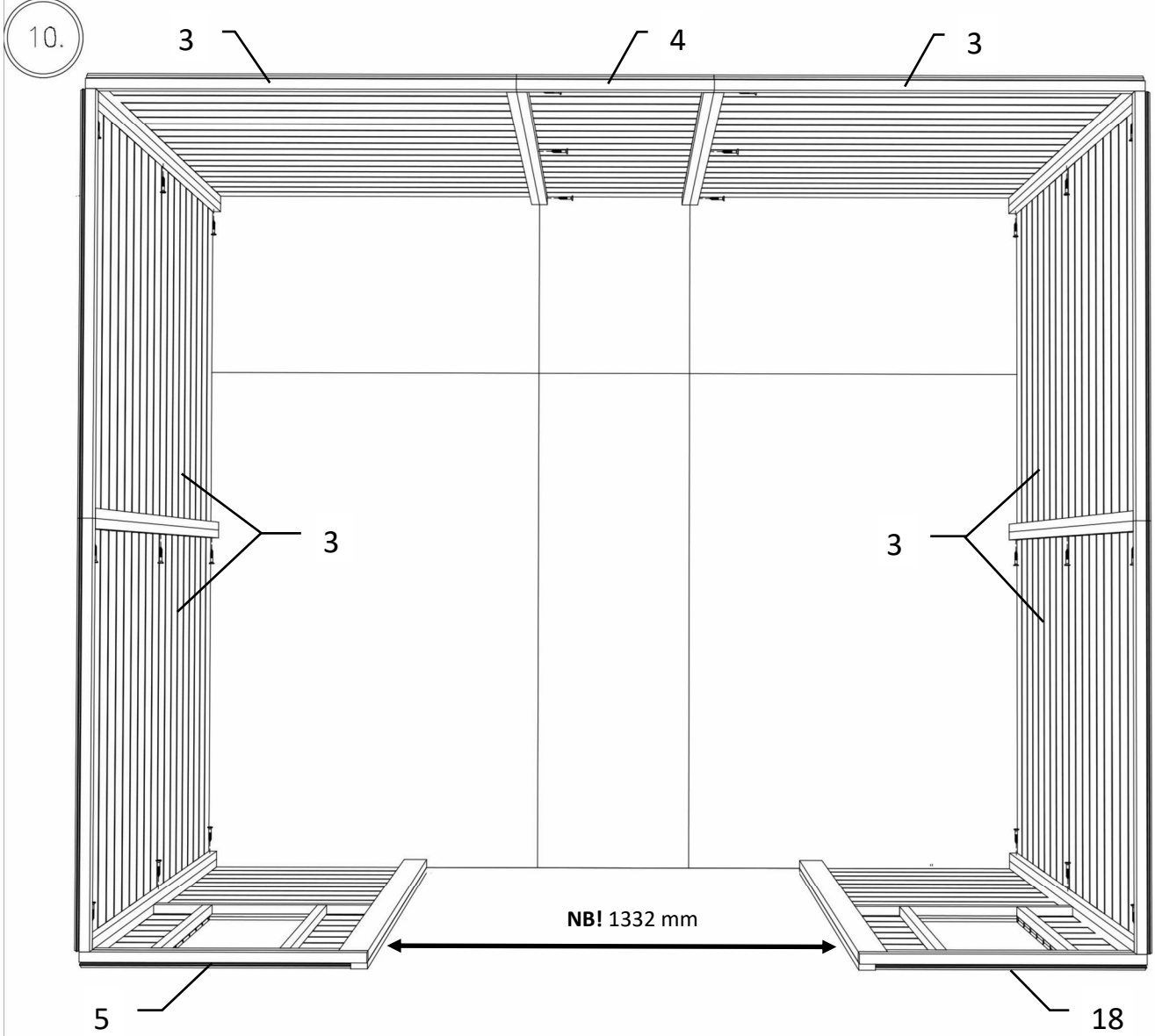

OTFEL10x8

13.

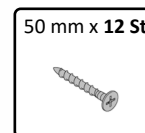
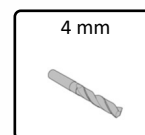
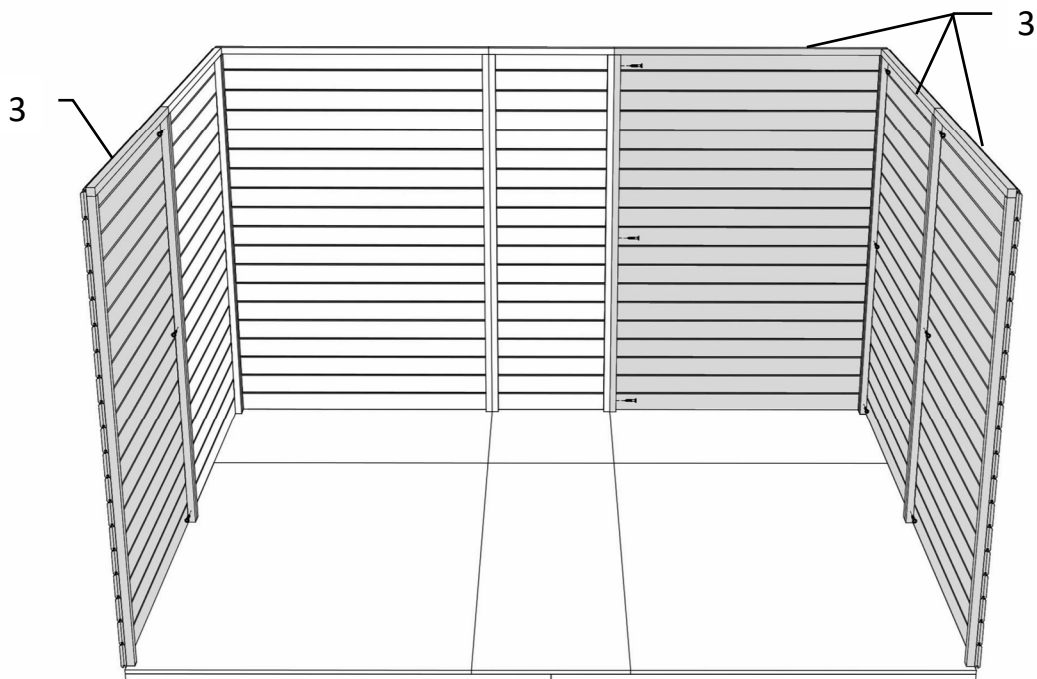

14.

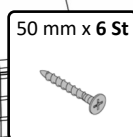
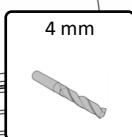
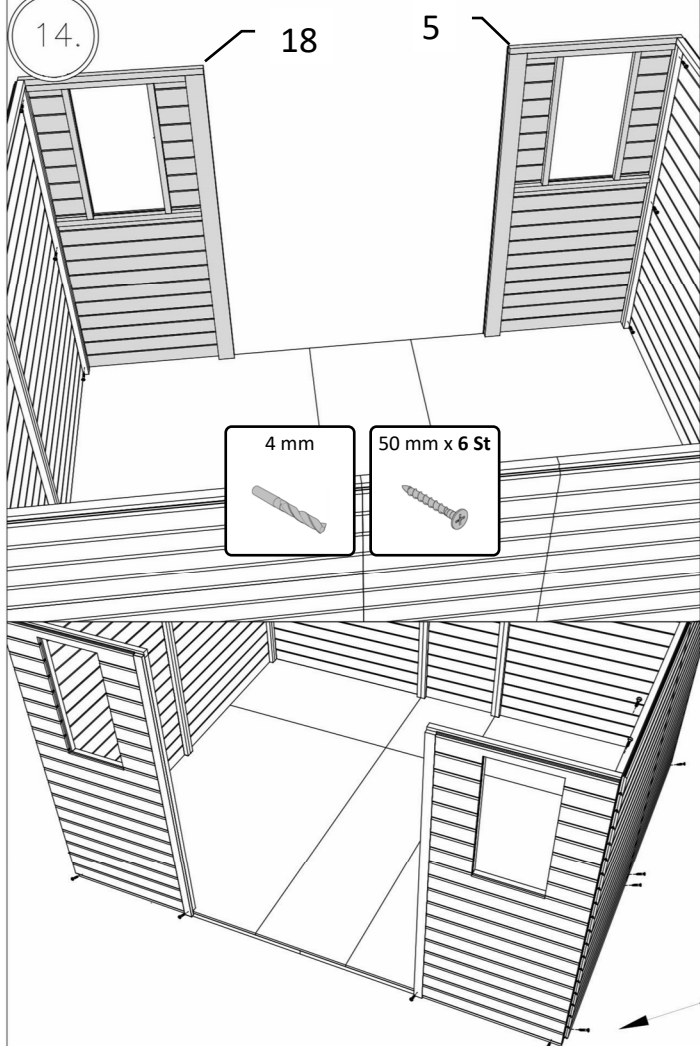

15.

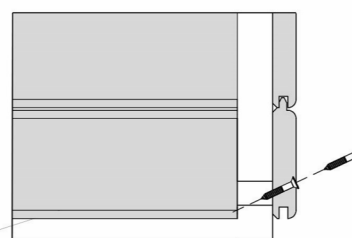
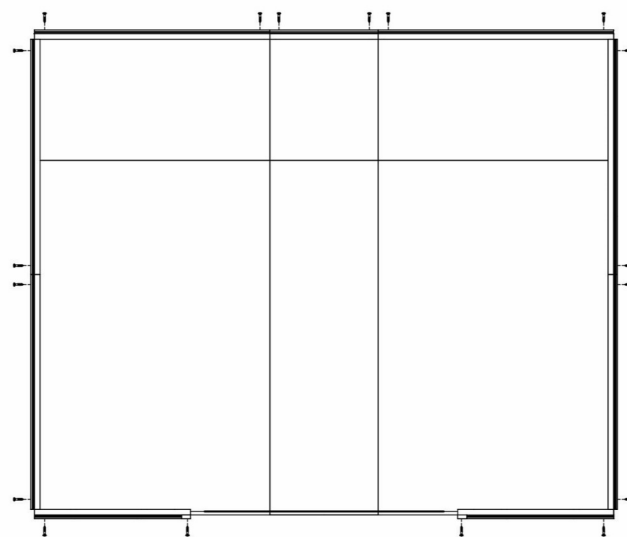
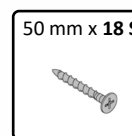
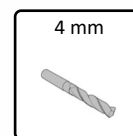

OTFEL10x8

13.

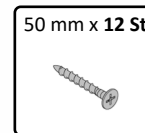
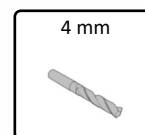
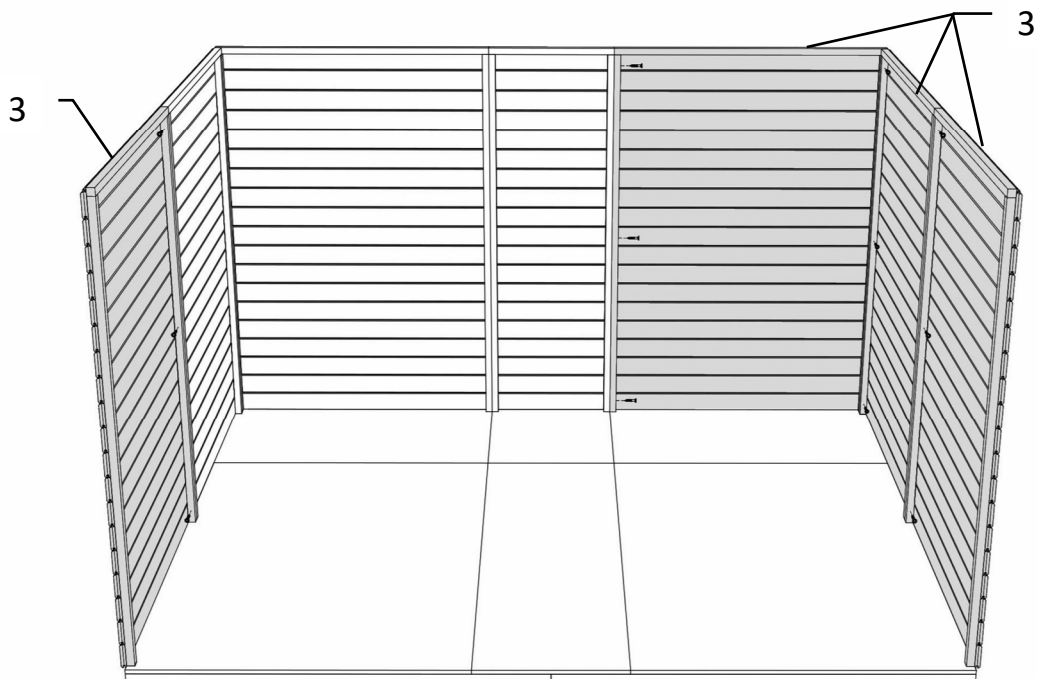

14.

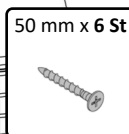
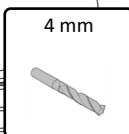
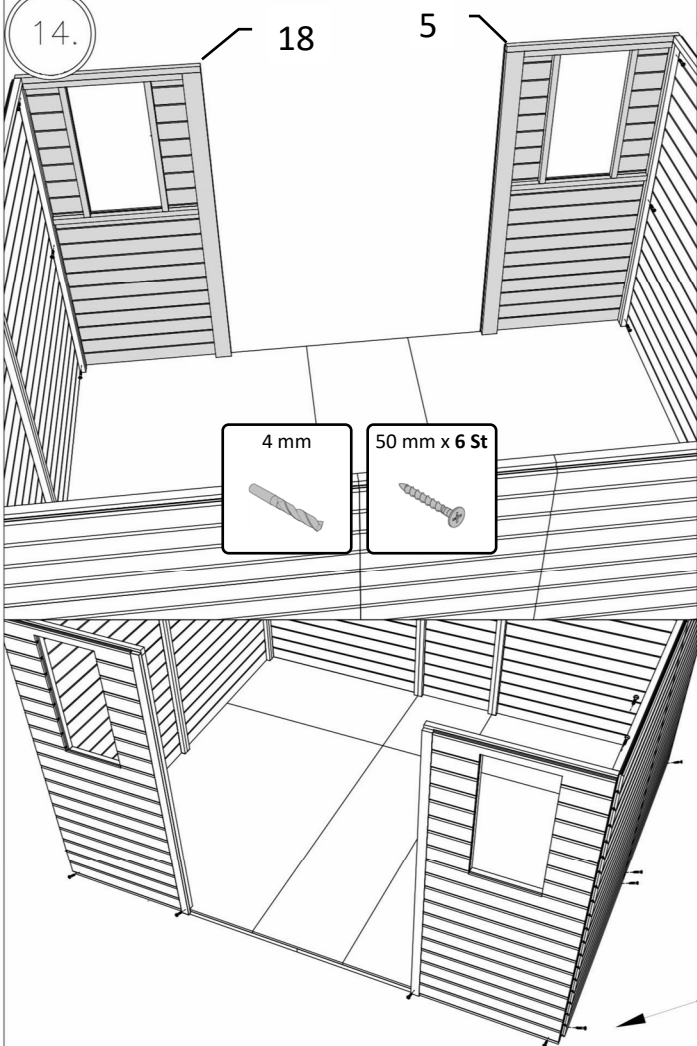

15.

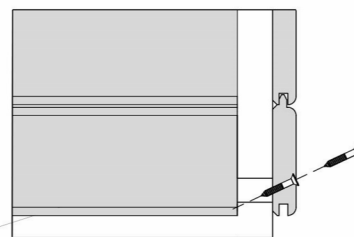
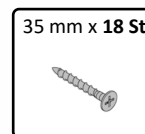
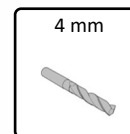
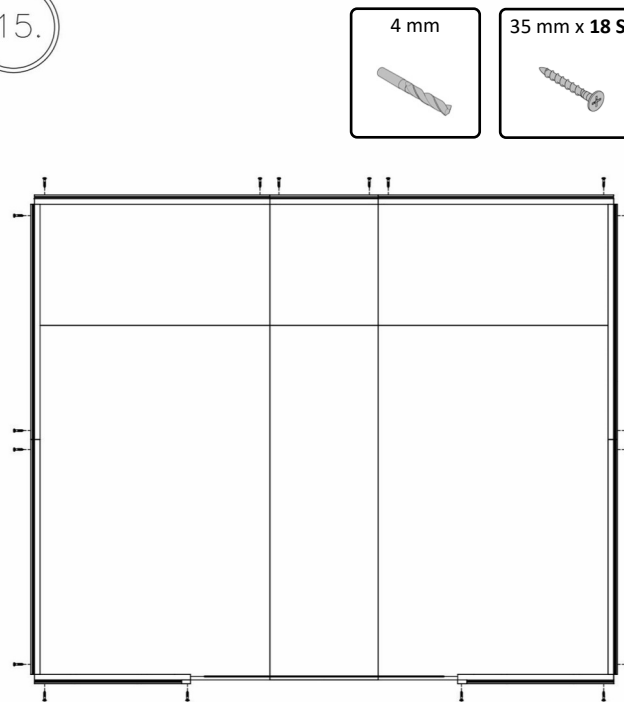

OTFEL10x8

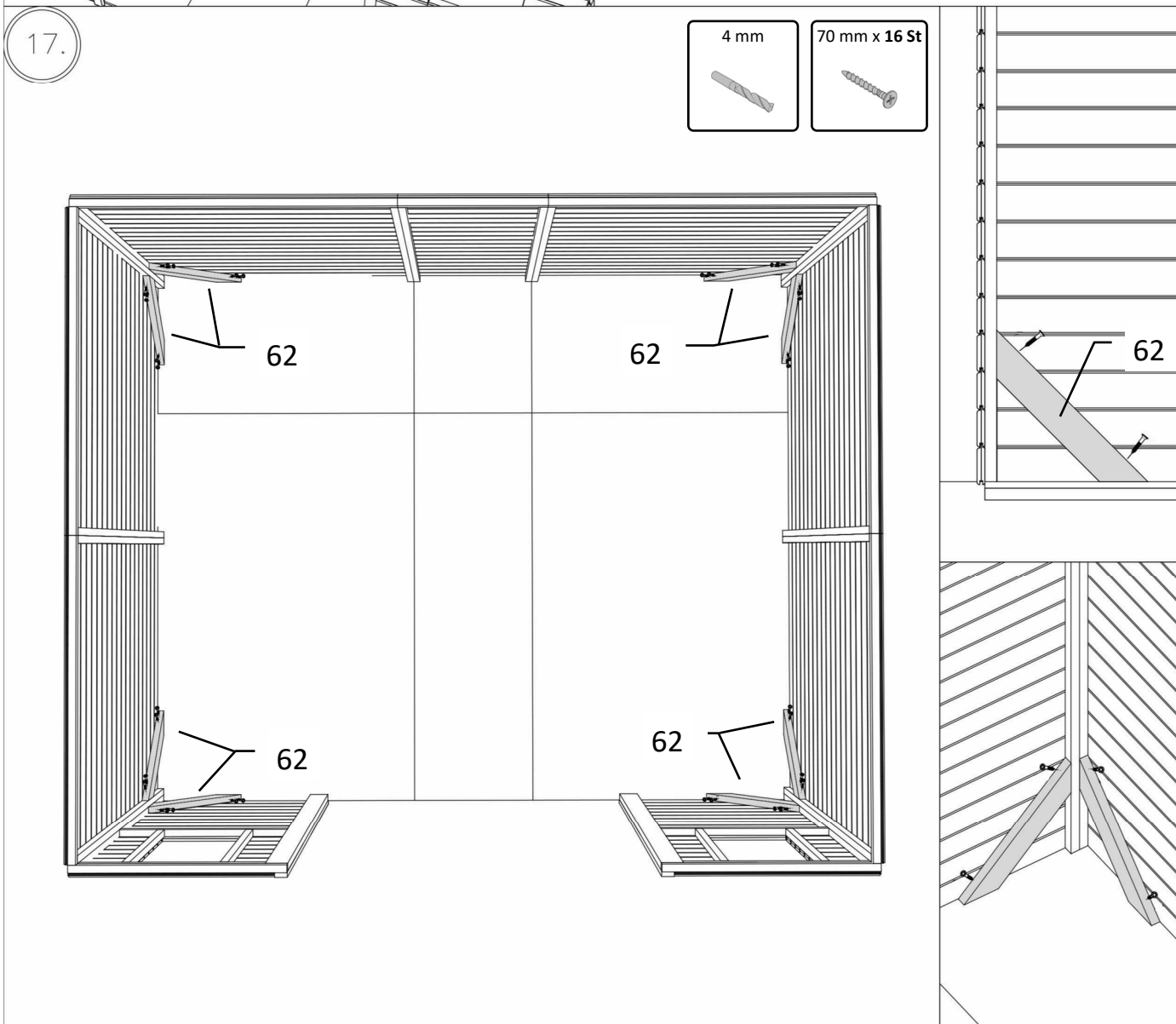
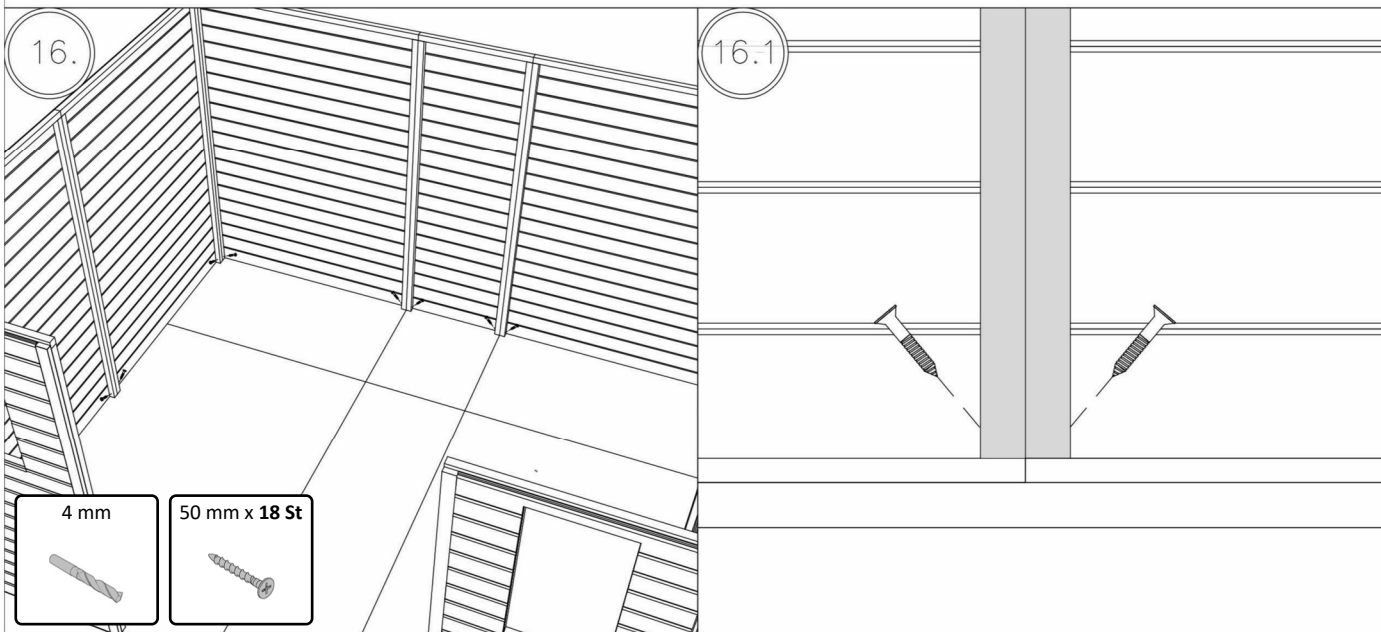

OTFEL10x8

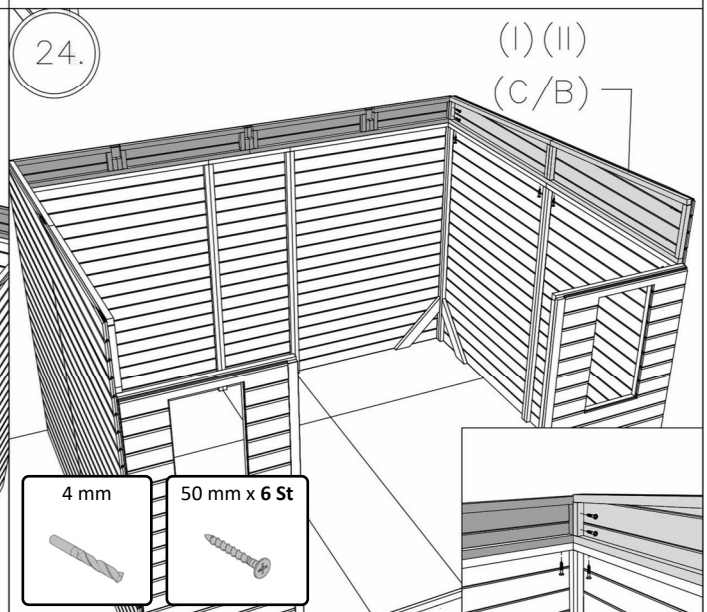
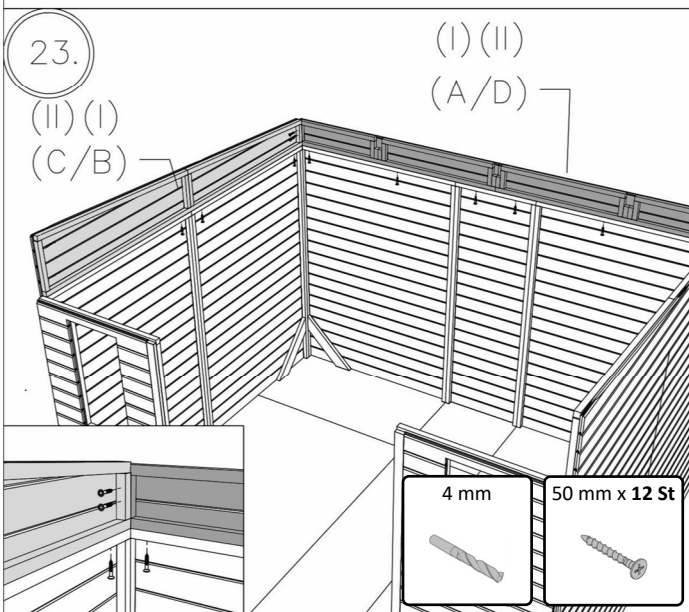
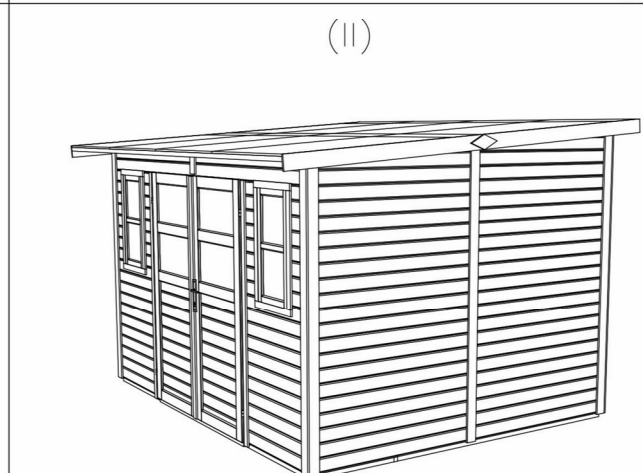
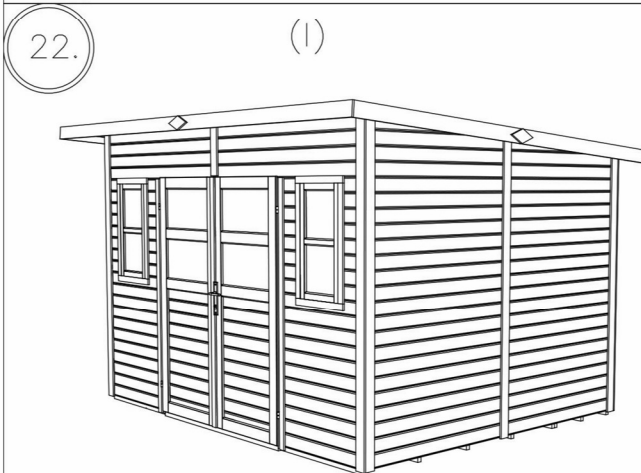
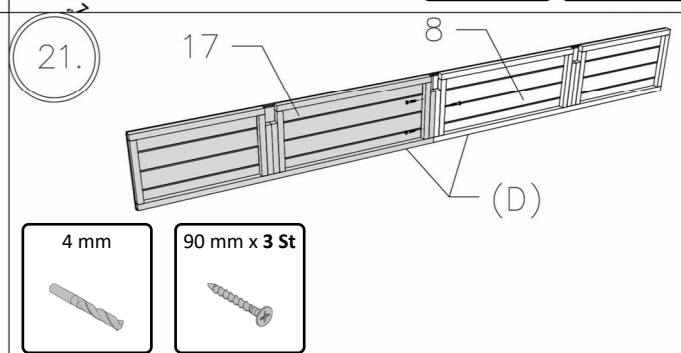
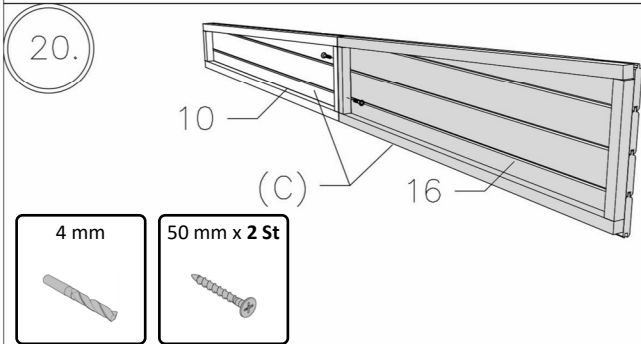
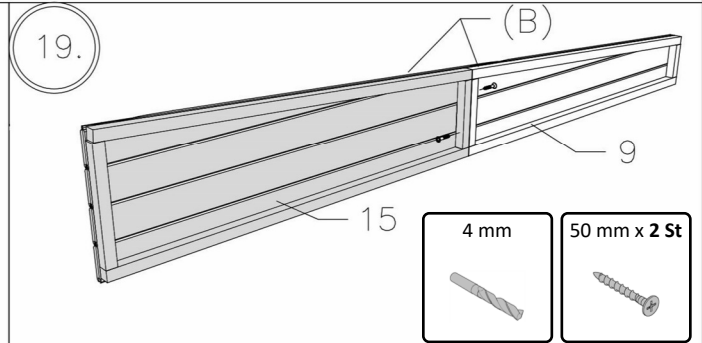
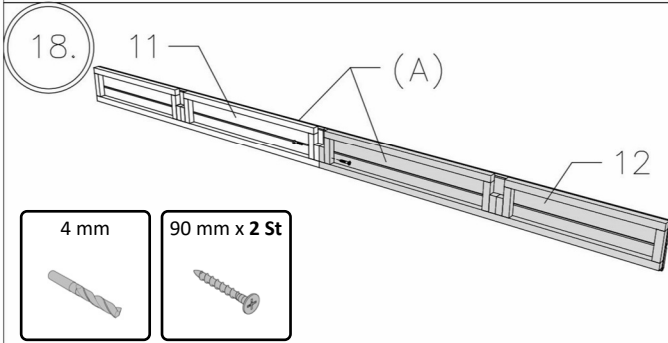

OTFEL10x8

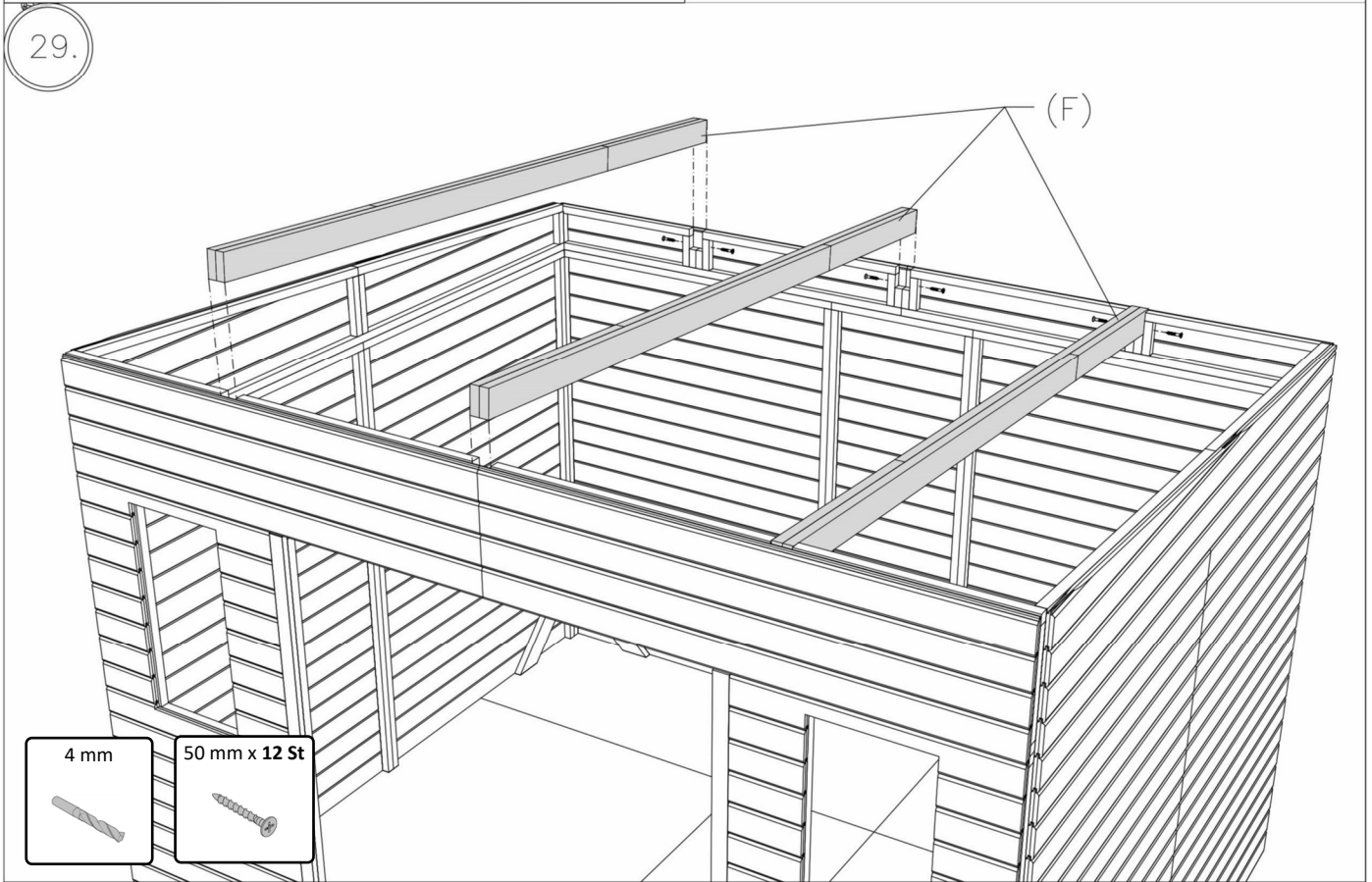
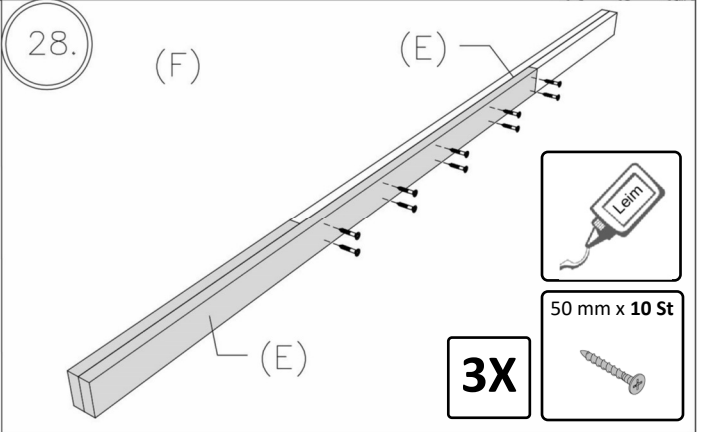
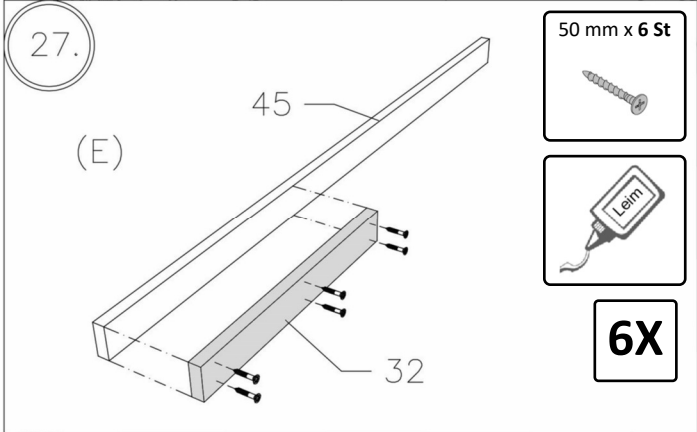
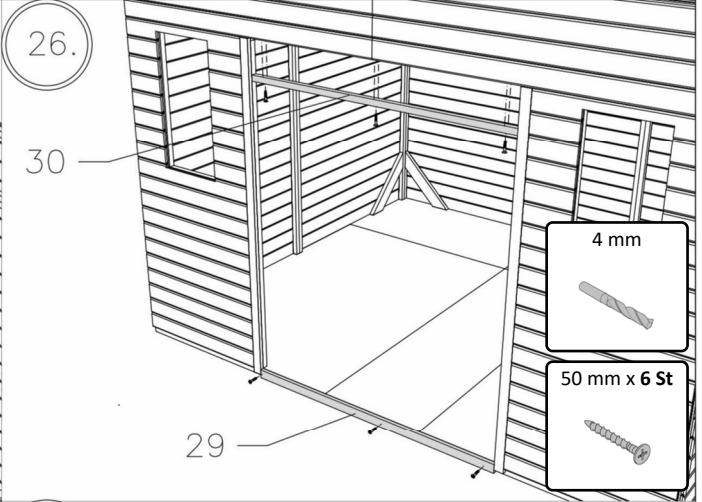
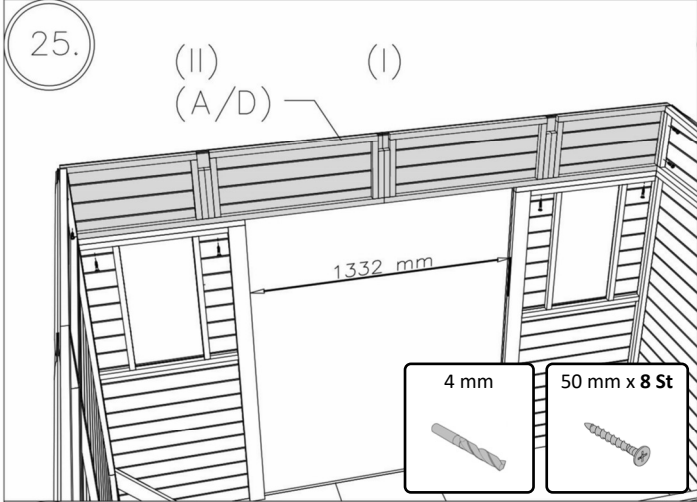

OTFEL10x8

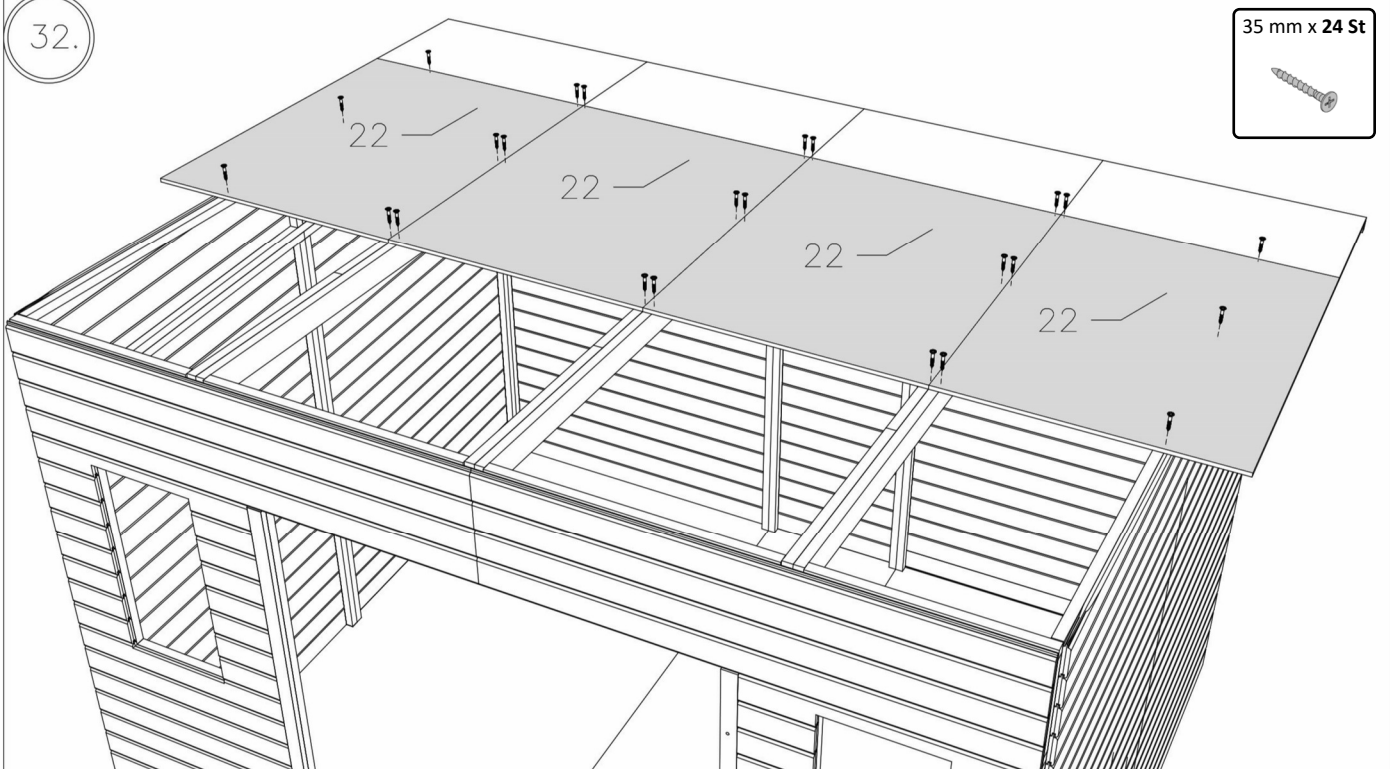
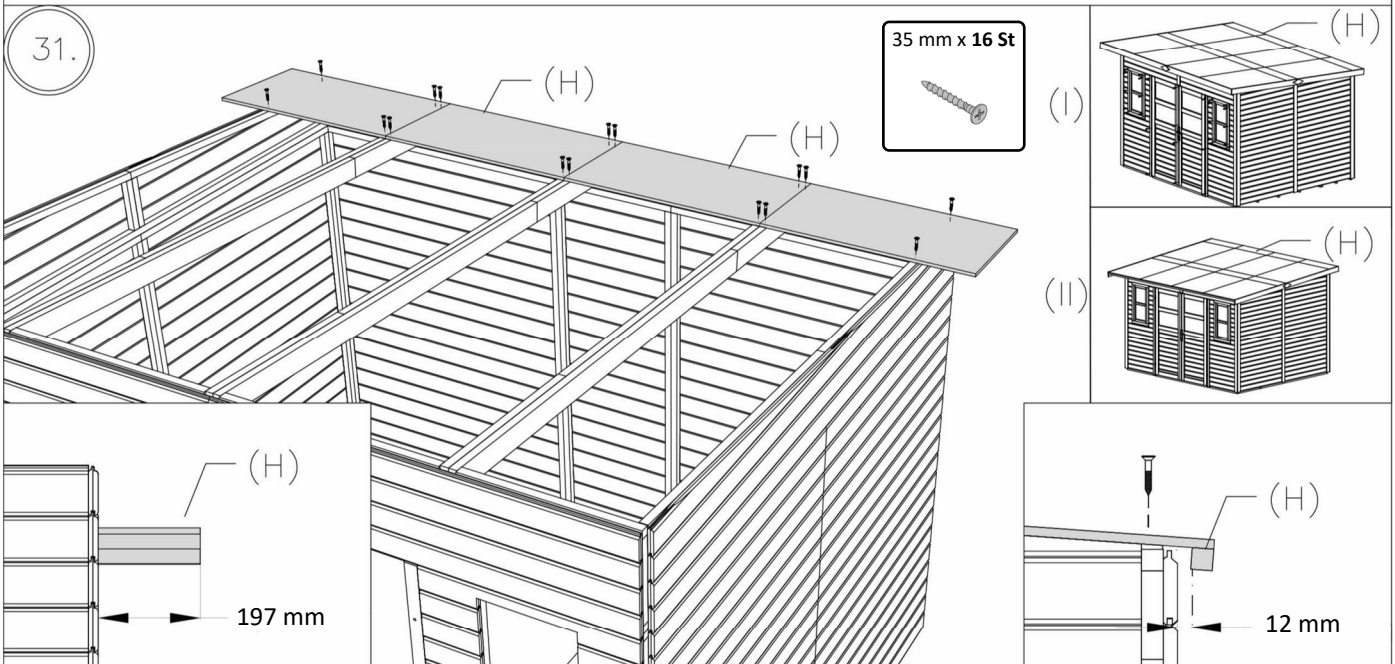
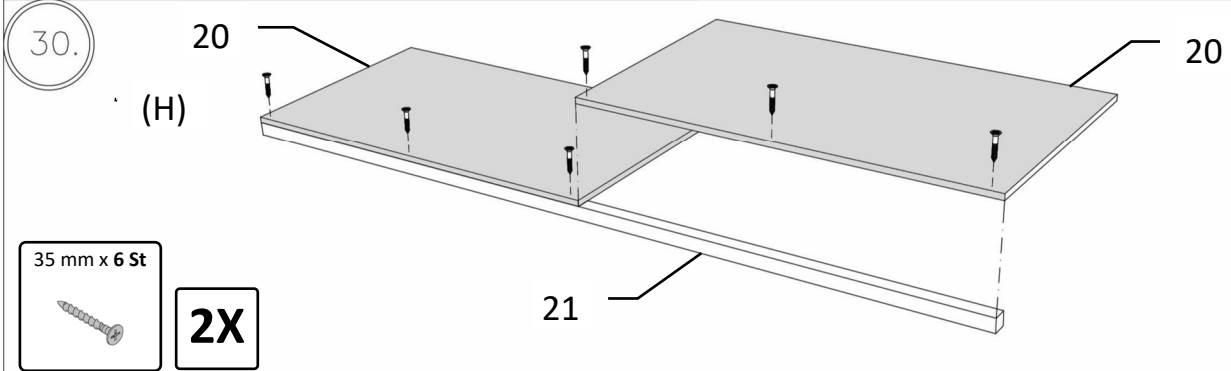

OTFEL10x8

33.

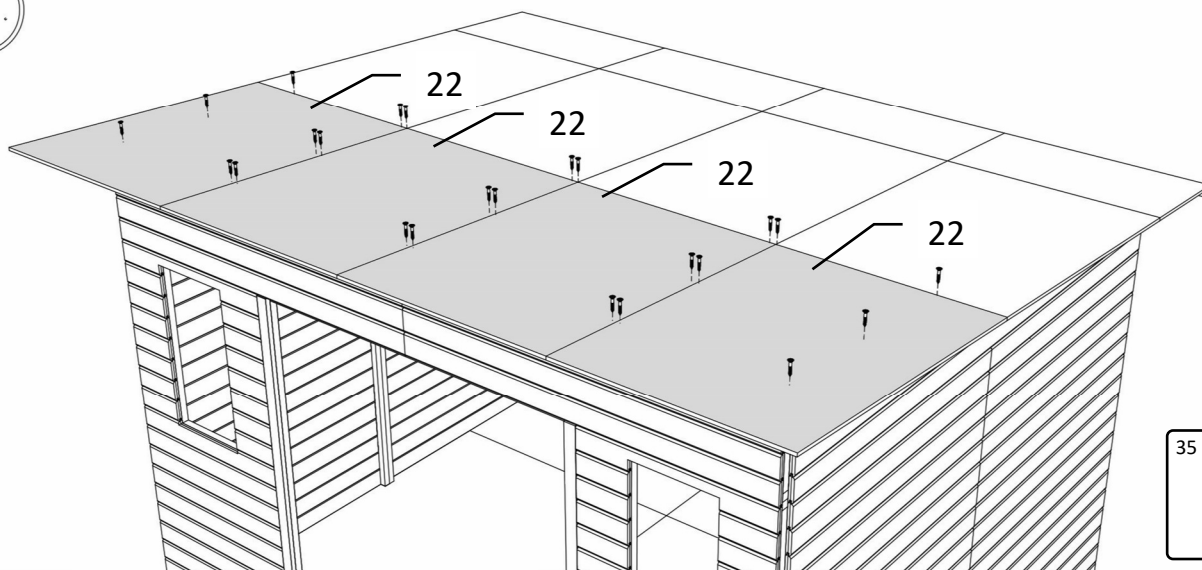

34.

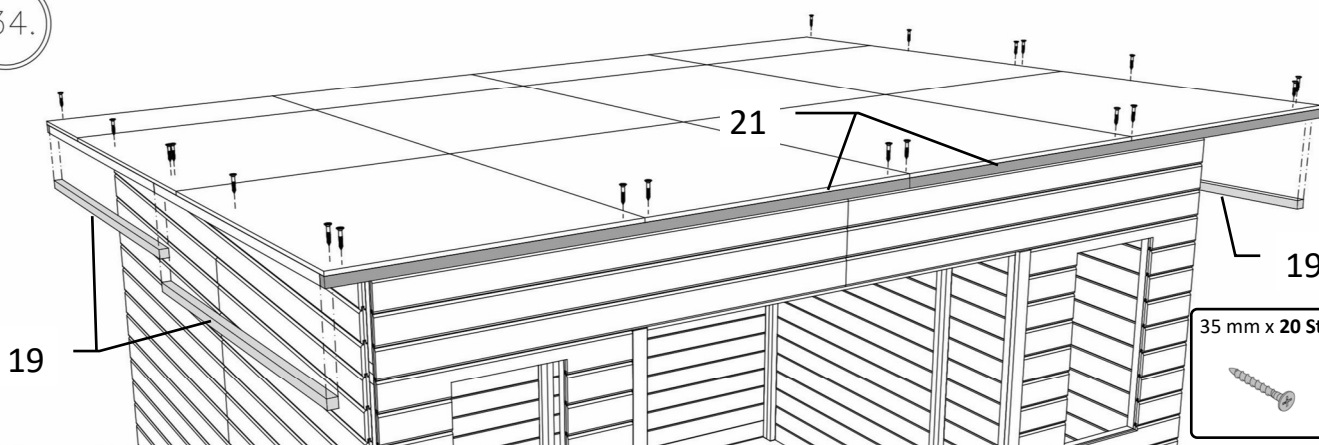

35.

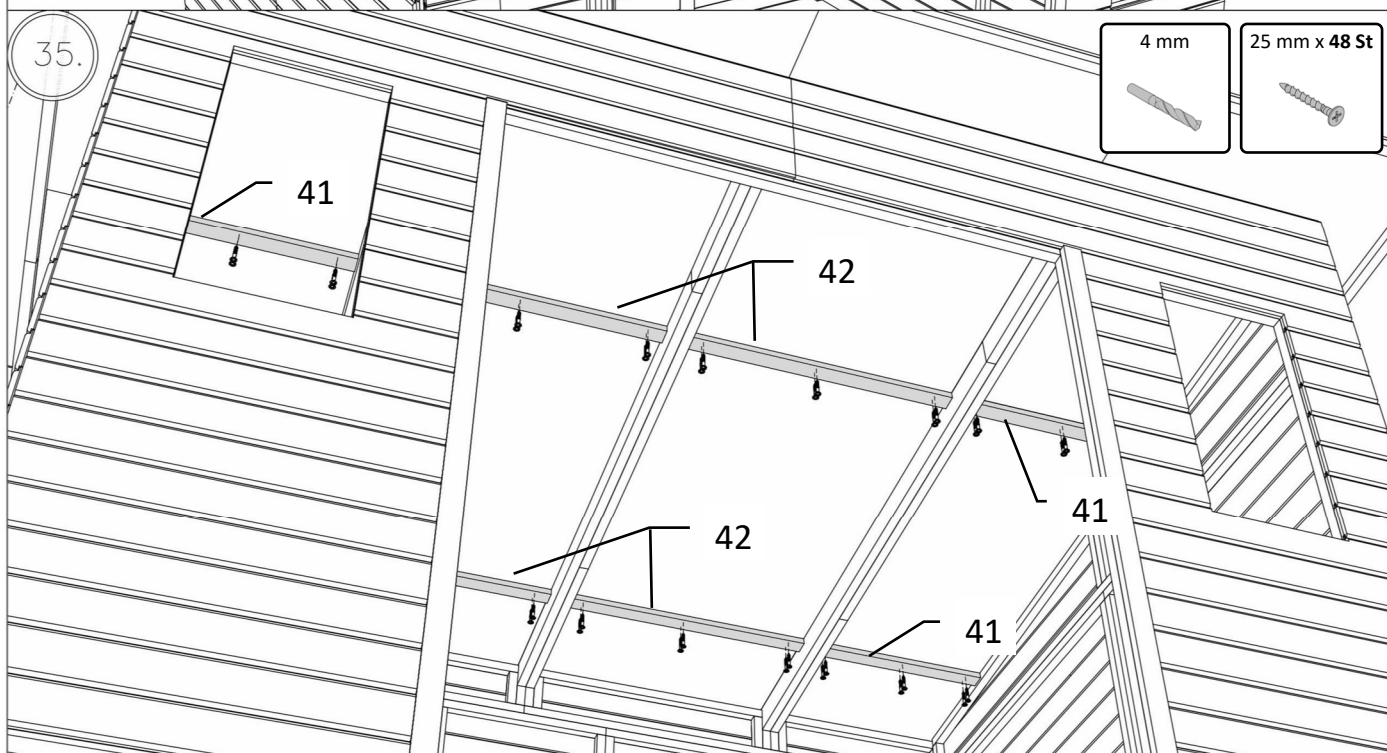

OTFEL10x8

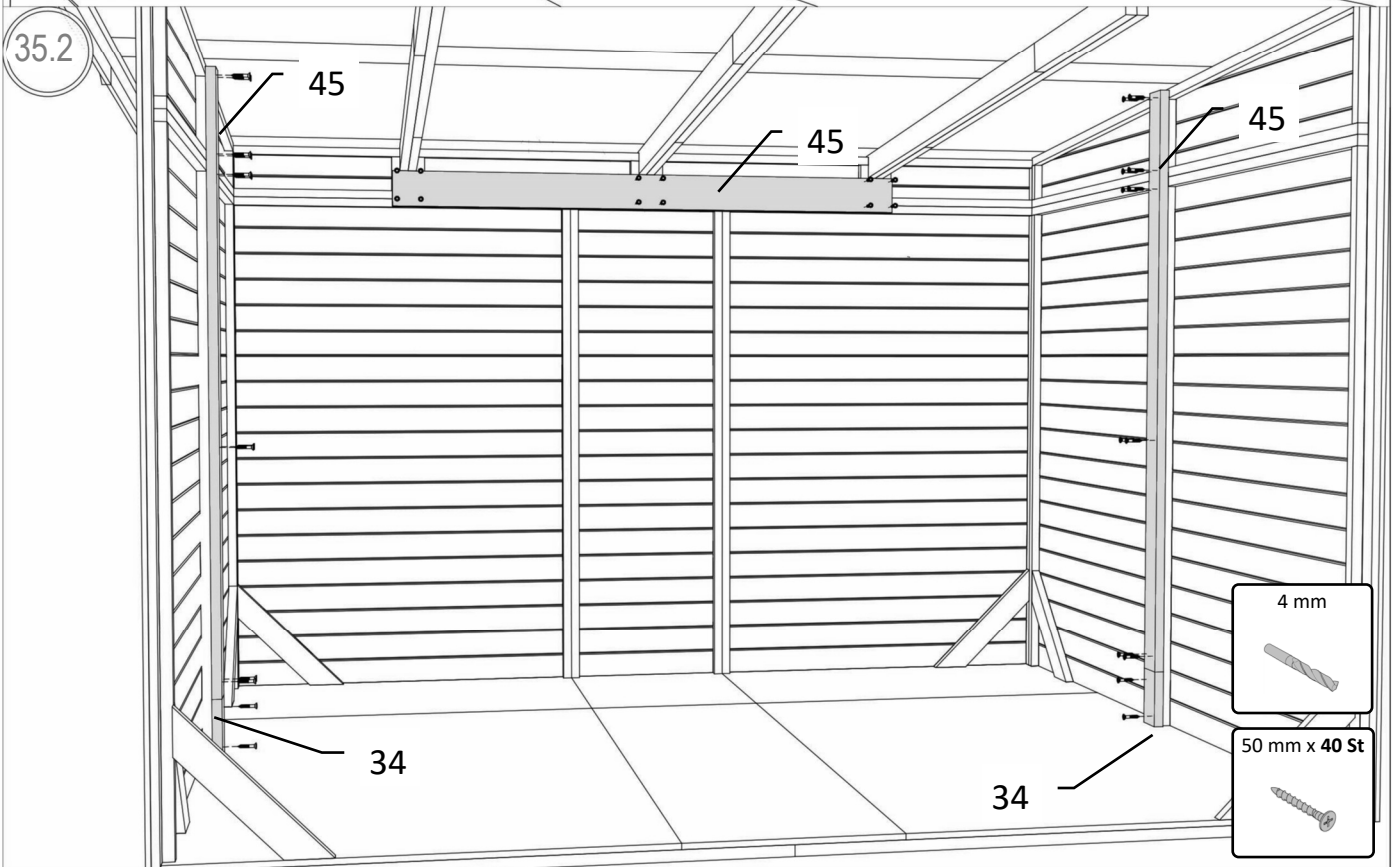
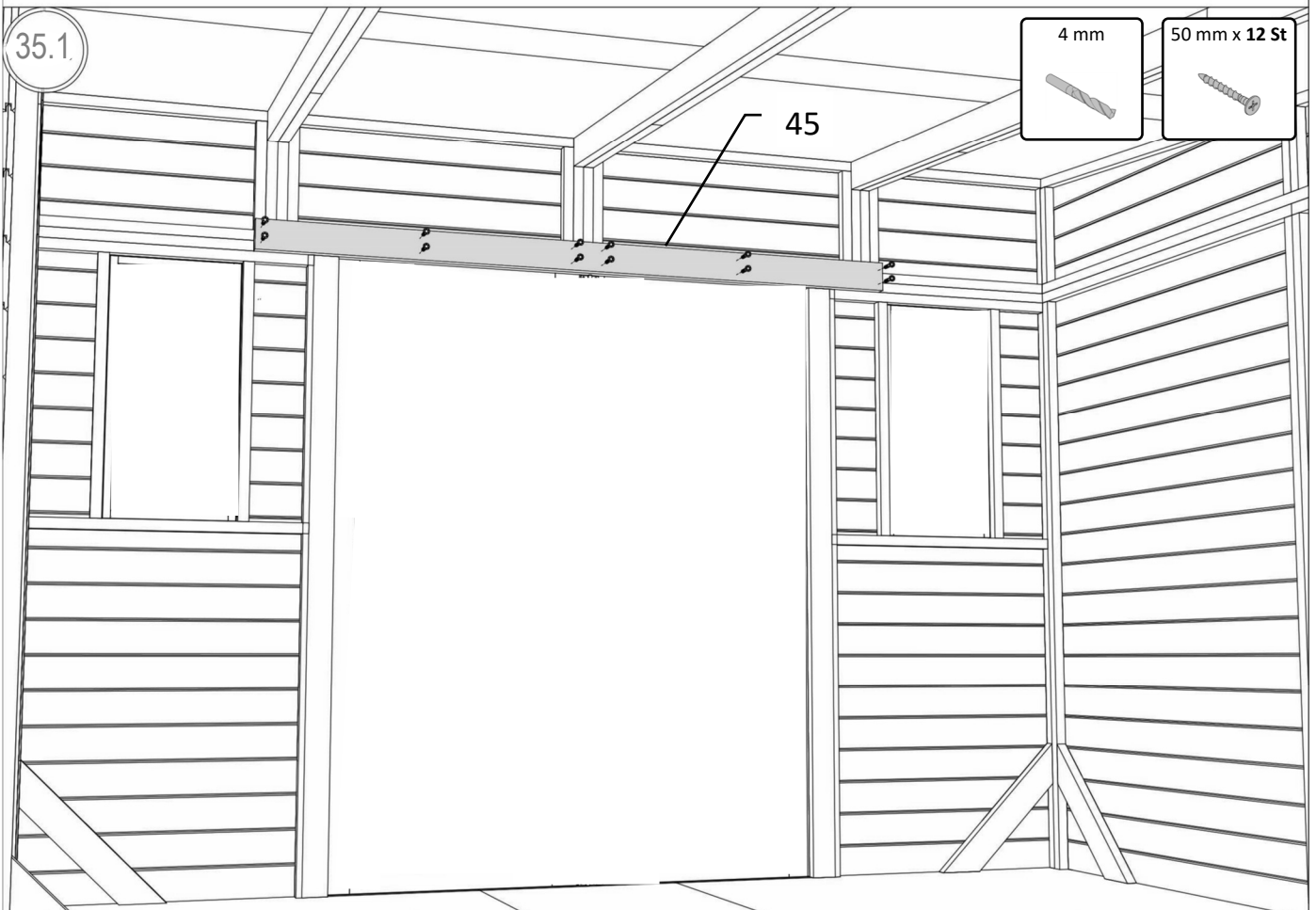

OTFEL10x8

36.

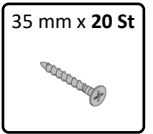
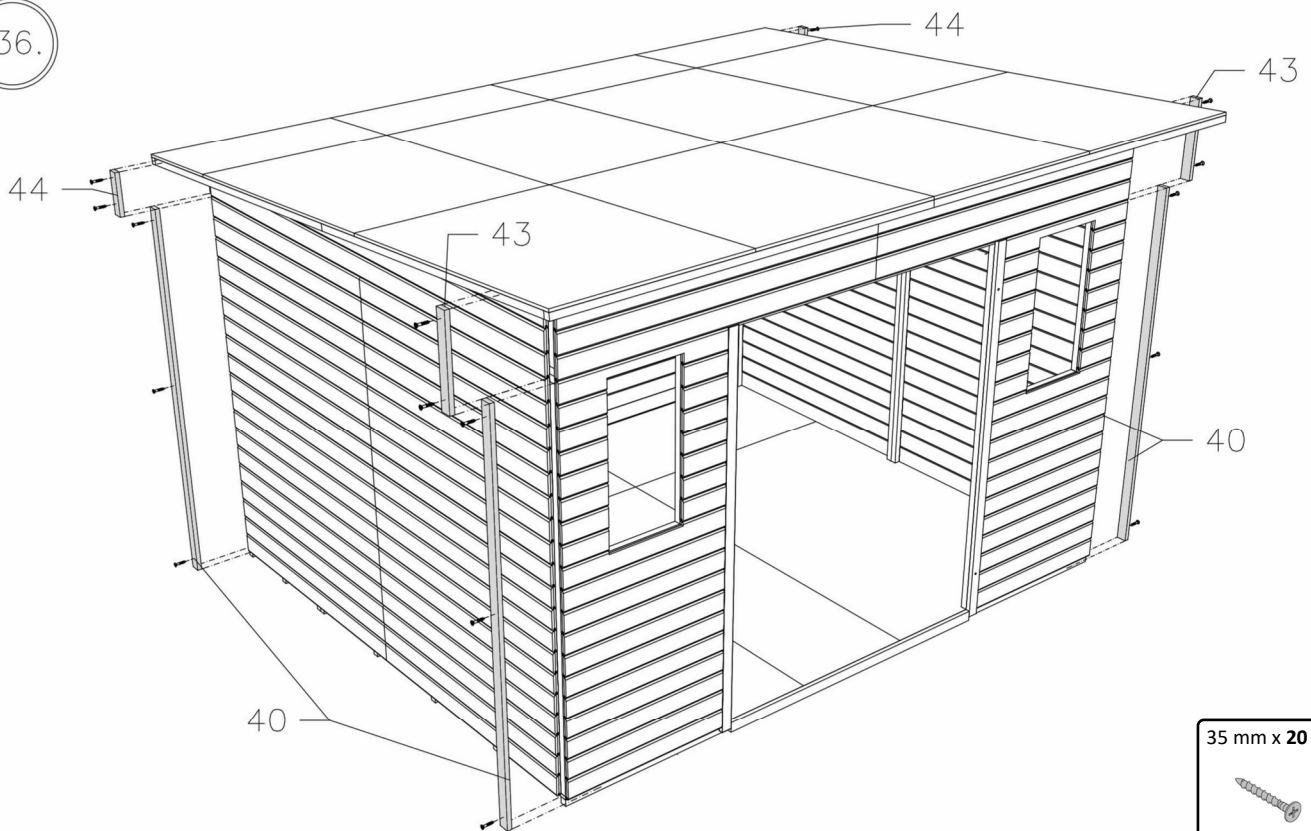

37.

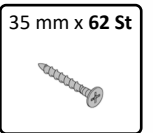
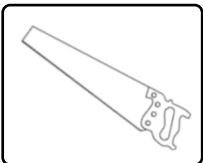
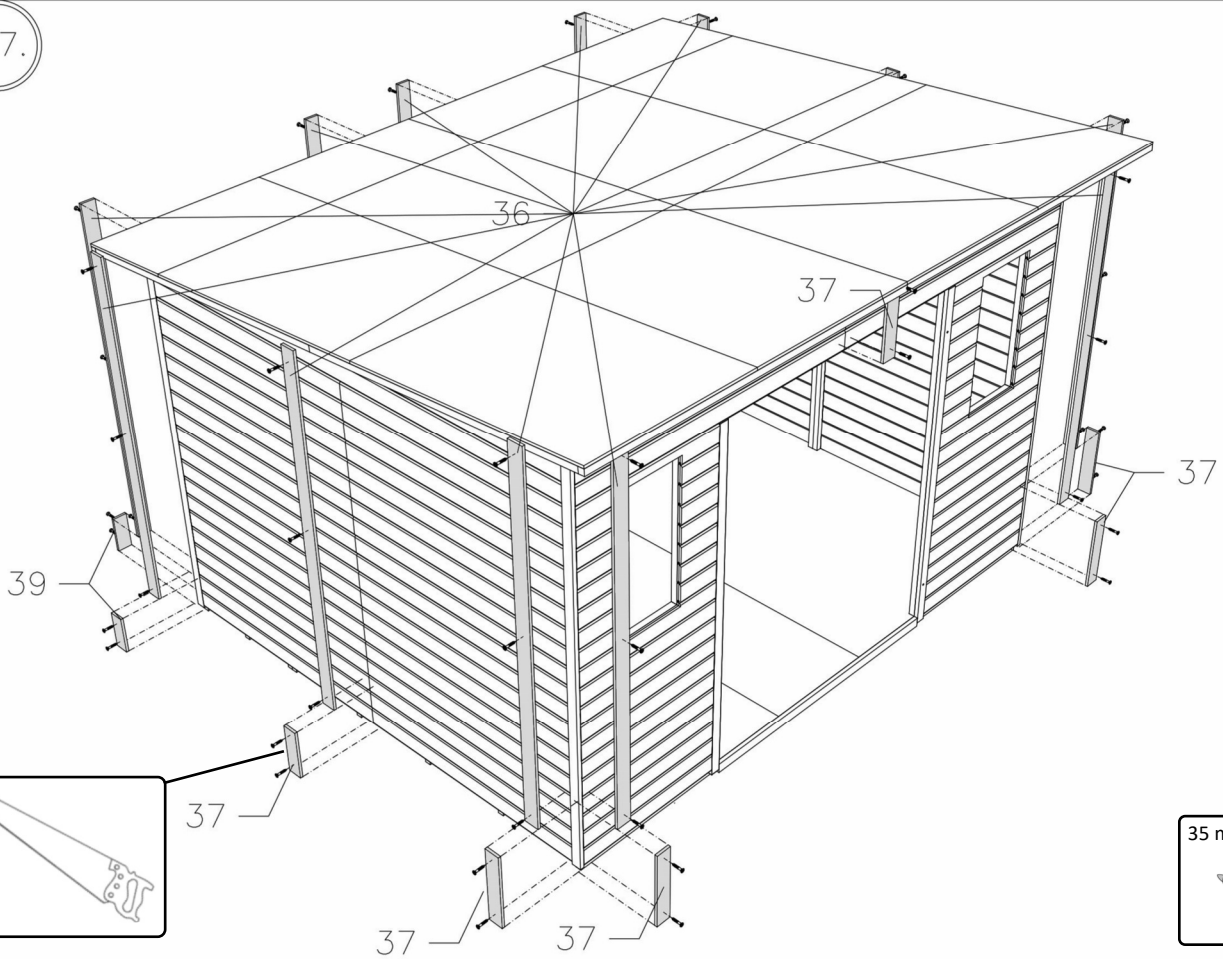

OTFEL10x8

38.

39.

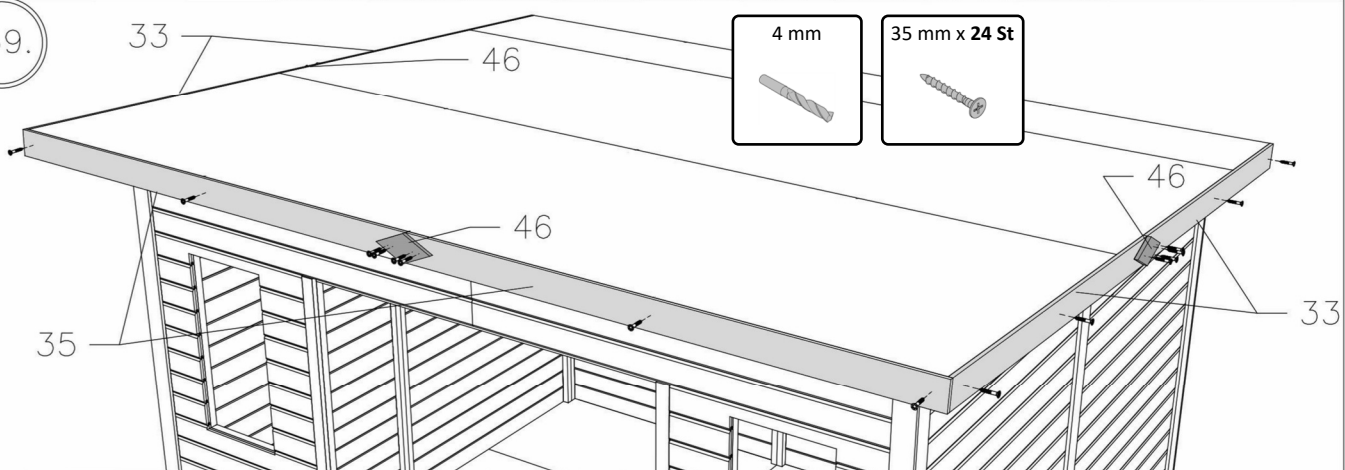

40.

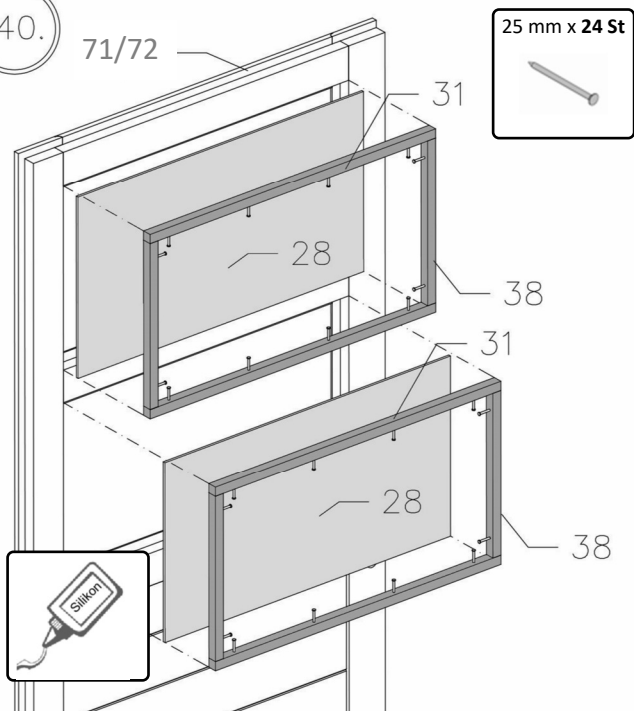

41.

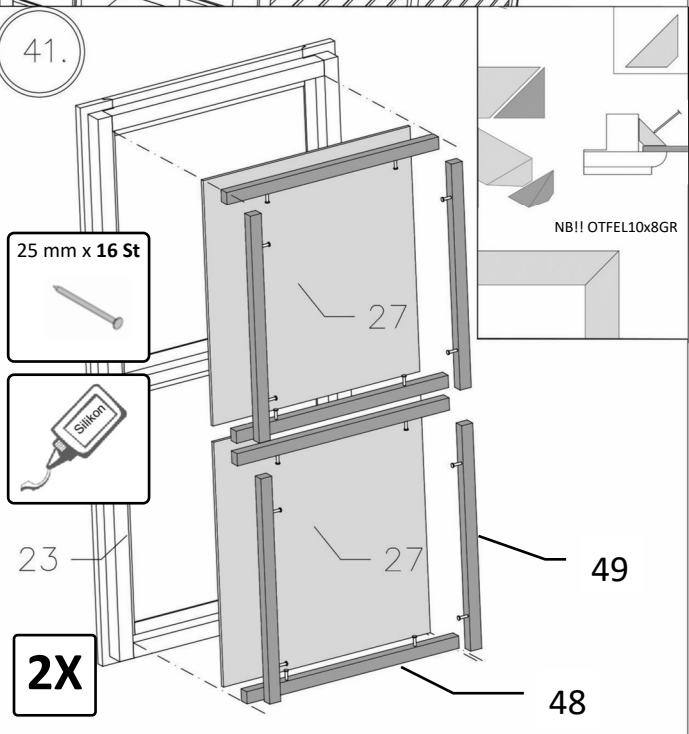

OTFEL10x8

42.

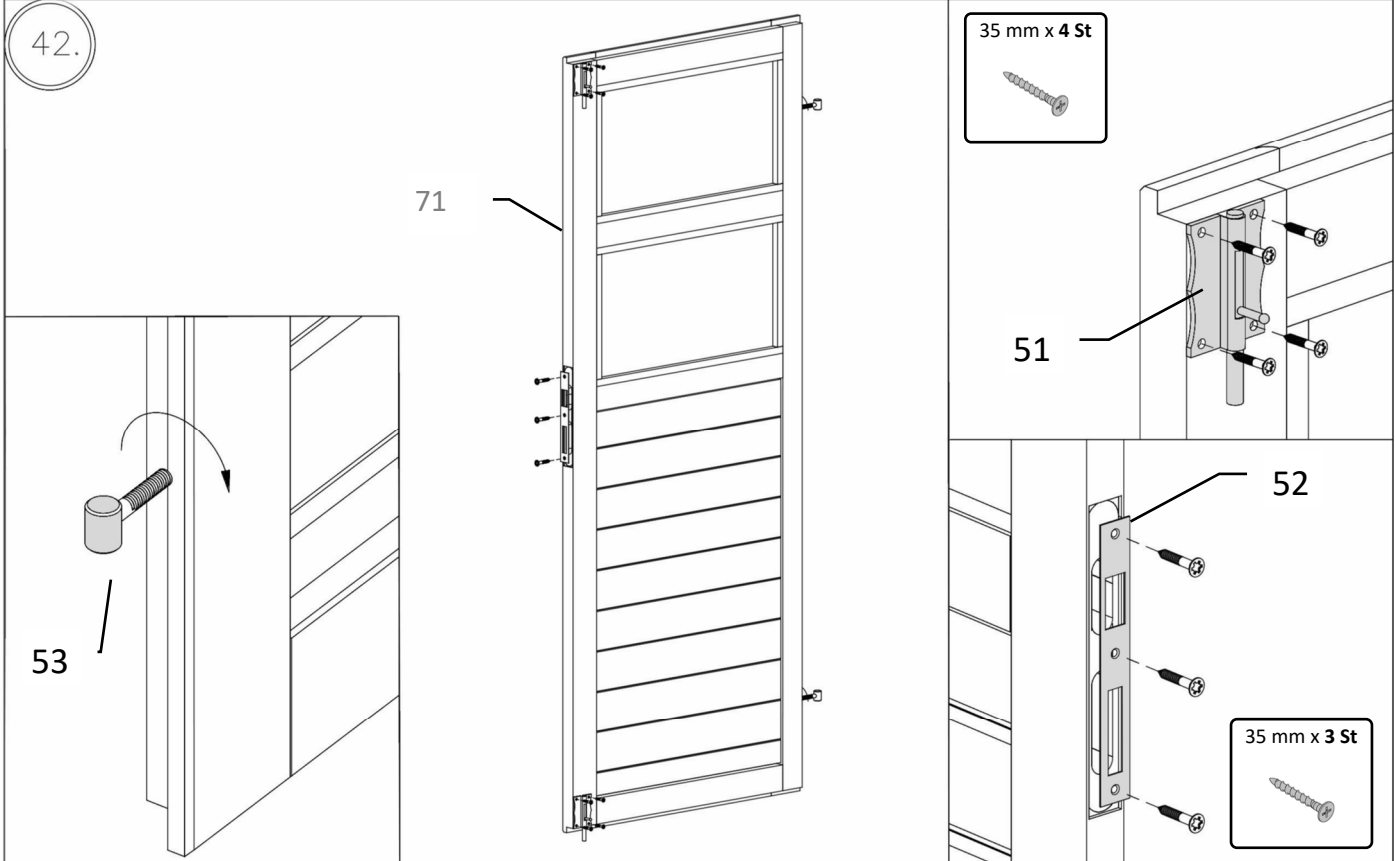

43.

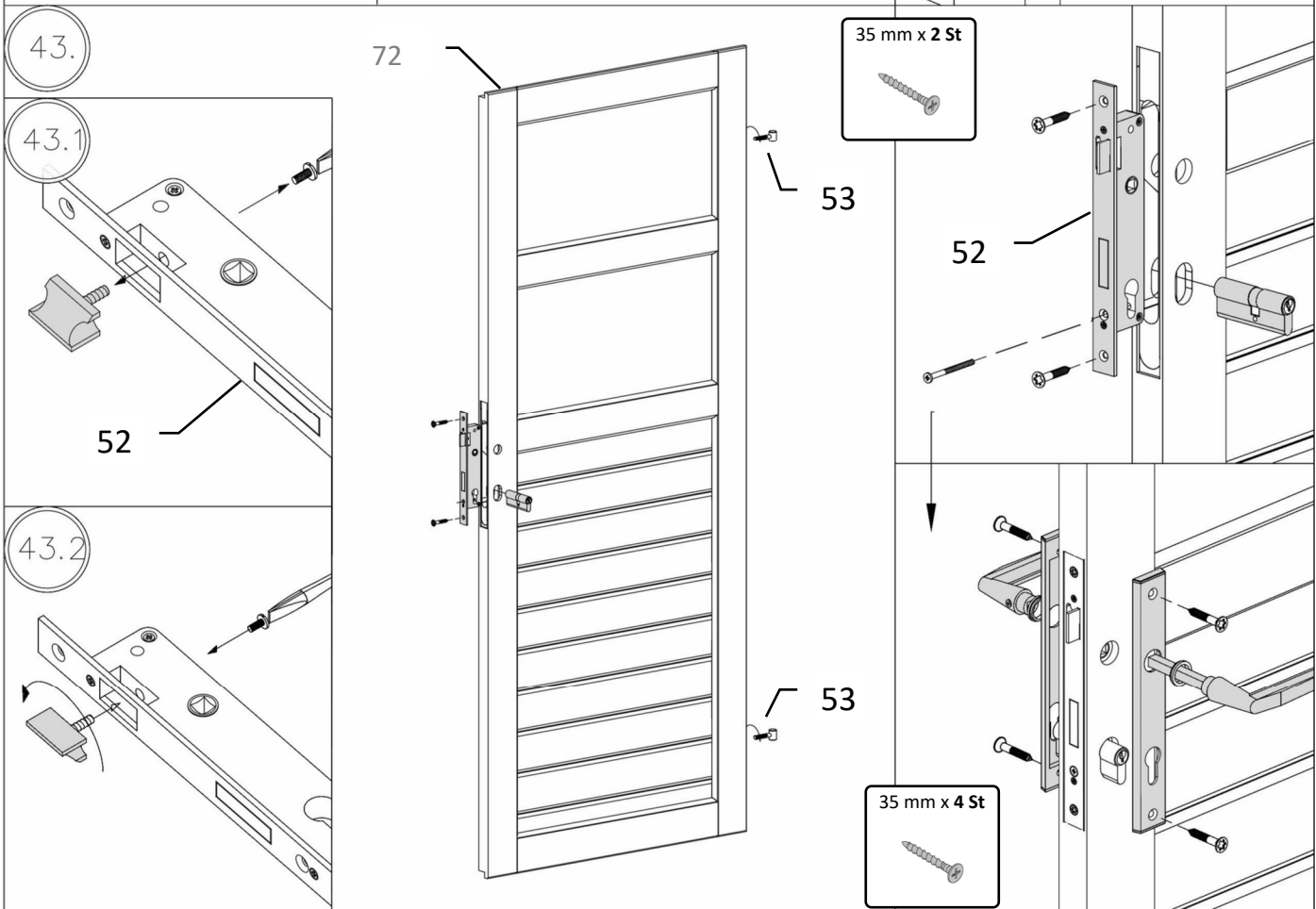

OTFEL10x8

