

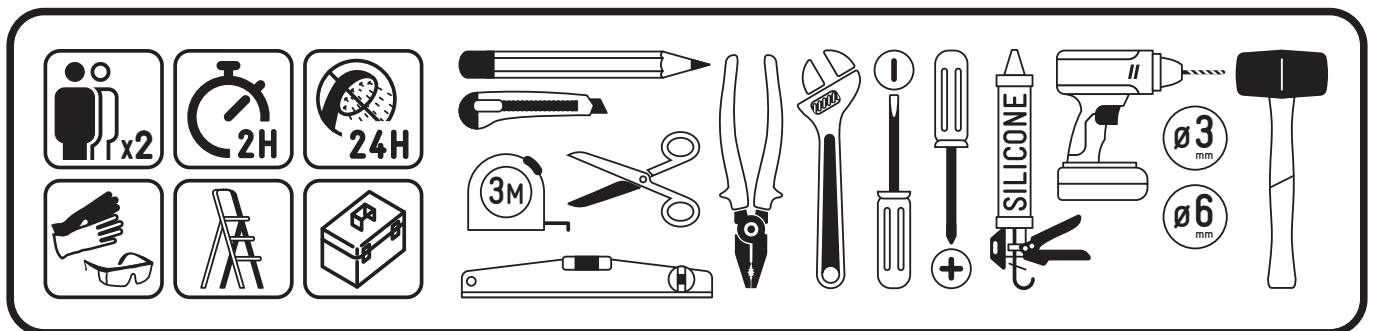

FAC957

120x200x0,6CM

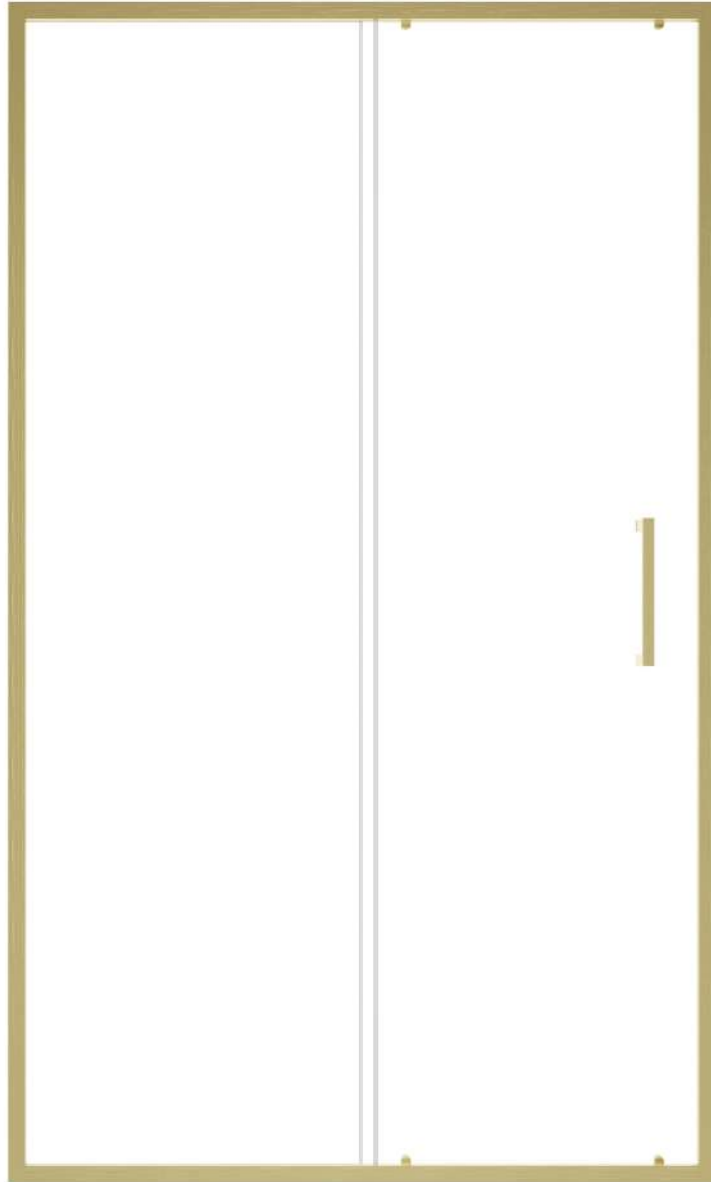

REVERSIBLE INSTALLATION

DE REVERSIBLE INSTALLATION

ES INSTALACIÓN REVERSIBLE

EN REVERSIBLE INSTALLATION

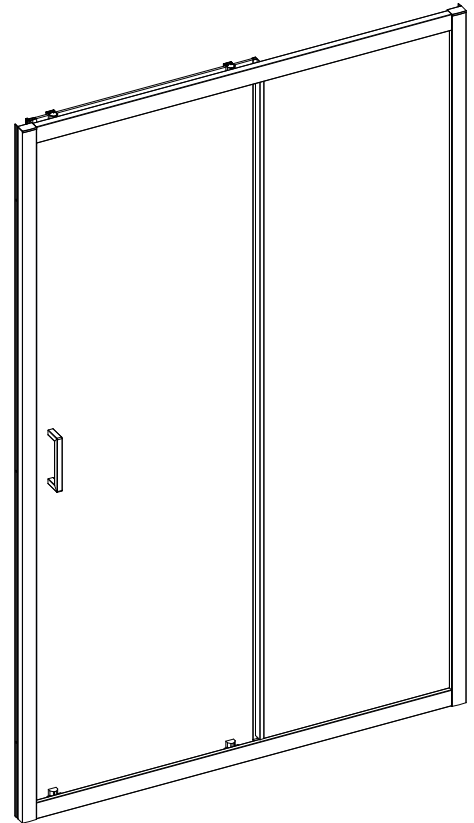
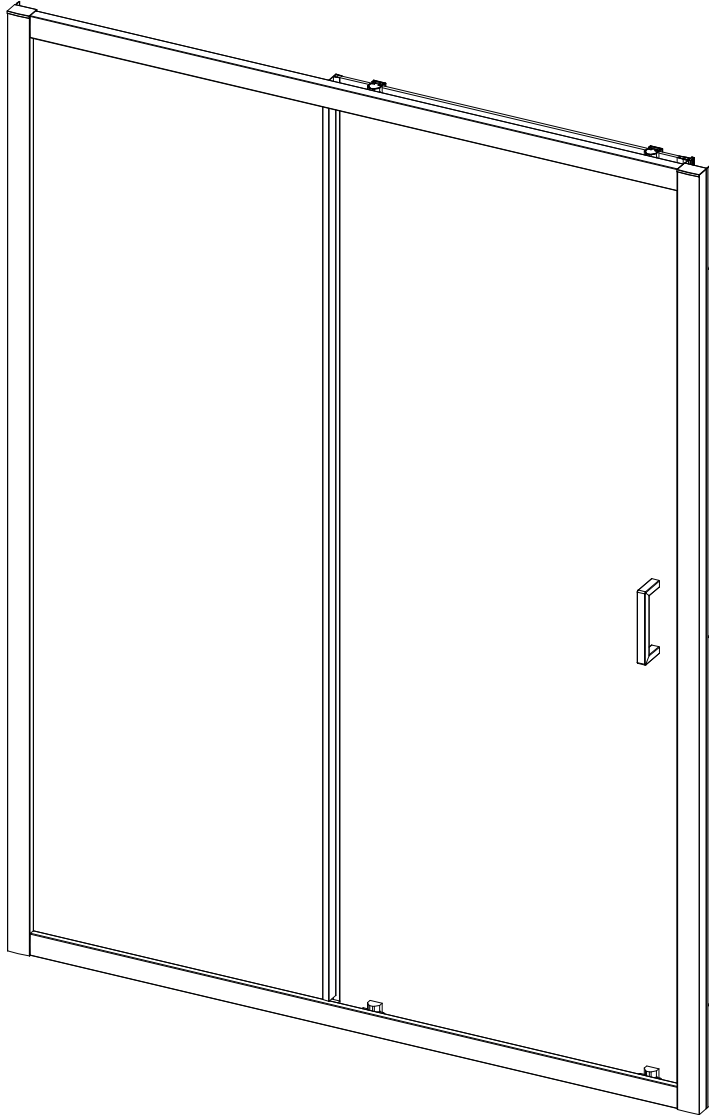

LINKSINSTALLATION

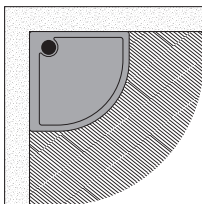

DE LINKSINSTALLATION
ES INSTALACIÓN A LA IZQUIERDA
EN SET ON THE LEFT

RECHTSINSTALLATION

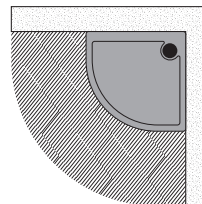

DE RECHTSINSTALLATION
ES INSTALACIÓN A LA DERECHA
EN SET ON THE RIGHT

GARANTIE

AURLANE-Produkte haben eine Garantie von 2 Jahren, nur auf Ersatzteile. Da die Arbeit nicht von uns durchgeführt wird, wird von AURLANE keine Arbeitsgarantie gewährt. Im Falle eines nachgewiesenen Herstellungsfehlers oder bei Bruch eines Elements können diese Elemente bei dem Händler bestellt werden, der diese Produkt verkauft hat. Es wird in keinem Fall der Arbeitsaufwand für den Austausch des Teils vom AURLANE übernommen.

Der Einbau dieser Badewannenabtrennung glas muss nach den Regeln der Technik erfolgen. Unser Unternehmen lehnt jegliche Verantwortung ab und behält sich das Recht vor, seine Garantie nicht zu gewährleisten, falls dieses Produkt nicht von qualifiziertem Personal installiert wird. Im Falle einer Anfrage über einen Artikel innerhalb Garantie ist es zwingend erforderlich, die Kaufrechnung für das Produkt vorzulegen.

Die verglasten Elemente sind in transparente Folie eingewickelt, damit der Zustand dieser Elemente beim Kauf überprüft werden kann. AURLANE unterstützt keine Ersatzlieferungen, falls ein Bruch nach dem Entfernen der Pakete im Lager oder während der Lieferung gemeldet wird. Der Bruch des Glases wird nicht von der Garantie übernommen, wenn er nicht eindeutig auf dem Lieferschein angegeben ist.

Es ist wichtig, den Zustand jedes Artikels beim Auspacken zu überprüfen. Nach einer Frist von 14 Tagen nach dem Kauf des Produkts werden keine Reklamationen bezüglich der Qualität des Produkts mehr berücksichtigt. Denken Sie daran, das Handbuch sowie einen offiziellen Kaufbeleg (Rechnung, Quittung und Produktetikett auf der Verpackung) für eventuelle Reklamationen oder Ersatzteilanfragen aufzubewahren.

Nichtanwendung der Garantie: falsche Montage, ungeeignete Warmwasserbereitung, mangelnde Wartung, Kalkstein, Unfall oder Stoß, Verwendung von abrasiven oder korrosiven Produkten, Veränderung der Beschichtung der ursprünglichen Oberfläche. Die Elektro- und Sanitärinstallation des Hauses entspricht nicht den gesetzlichen Vorschriften.

Die Nichtbeachtung der Gebrauchsanweisung und der Installationsmethoden führt zum Erlöschen der Garantie.

EINRICHTUNG

Die Montage muss mit mindestens zwei Personen erfolgen, um bestimmte Elemente befestigen zu können.

Die Glaselemente sind aus norm- und sicherheitstechnischen Gründen aus gehärtetem Glas. Da gehärtetes Glas so konstruiert ist, dass es beim Aufprall in (nicht scharfe) Stücke explodiert, sollten diese Gegenstände mit äußerster Sorgfalt behandelt werden. Aus dem gleichen Grund darf das an den Glaselementen zu befestigende Zubehör (Türgriffe, Ablagen, Brausehalter, Handtuchhalter usw.) nicht mit Gewalt festgezogen werden. Sie können die Glaselemente schützen, indem Sie sie auf Decken oder Teppichstücke legen. Niemals ein Glasteil schräg stellen.

REINIGUNG UND PFLEGE**REGELMÄSSIGE REINIGUNG :**

Verwenden Sie einen Duschschwamm mit einem pH-neutralen Reinigungsmittel (Mehrflächen-Haushaltsreiniger, Geschirrspülmittel). Wenn es schwierig ist, den Schmutz zu entfernen, verwenden Sie mit Wasser verdünnten weißen Alkoholesig und spülen Sie ihn dann mit klarem Wasser ab.

**KALKREINIGUNG :**

Verwenden Sie ein weiches Tuch und Zitronensaft und/oder warmen weißen Alkoholesig und spülen Sie dann mit klarem Wasser nach. Der einfachste Weg, Ihre Wände sauber zu halten, ist die Verwendung eines Abziehers. Wenn Sie direkt nach dem Duschen abwischen, minimieren Sie die Kalkbildung auf den Oberflächen.



Verwenden Sie niemals einen Reiniger, der Polierkörner, Aceton, Chlor, Ammoniak (Bleichmittel) oder andere aggressive Reiniger auf Säurebasis enthält. Diese Art von Produkten reagiert mit Effekten wie Kratzern auf Chrom.

GARANTÍA

Los productos AURLANE tienen una garantía de 2 años, solamente en las piezas. Debido a que la mano de obra e instalación no es realizada por el fabricante, AURLANE no aplicará ninguna garantía en la mano de obra e instalación.

En caso de defecto de fabricación constatado o rotura de algún elemento, estos elementos podrán ser solicitados al distribuidor que vendió este producto, sin embargo en ningún caso se tendrá en cuenta la mano de obra relativa a la reposición e instalación de la pieza a cargo de AURLANE.

La instalación de esta mampara de bañera debe realizarse de acuerdo con las reglas e instrucciones del artículo. Nuestra empresa declina toda responsabilidad y se reserva el derecho de no asegurar su garantía en caso de que este producto no sea instalado por personal cualificado.

En caso de solicitud de un artículo en garantía, es imprescindible aportar la factura de compra del producto.

Los elementos acristalados están envueltos en un film transparente que permite comprobar el estado de estos elementos en el momento de su compra. AURLANE no se hará cargo de la sustitución de estos elementos en caso de que se comunique una rotura tras la retirada de los bultos del almacén o durante la entrega. La rotura del cristal no está cubierta por la garantía si esta, no está claramente indicada en el albarán de entrega.

Es fundamental comprobar el estado de cada artículo al desembalar. No se tendrá en cuenta ninguna reclamación relativa a la calidad del producto transcurrido un plazo de 14 días desde la compra del producto. Para cualquier reclamación o solicitud de repuestos, recuerde conservar el manual de instrucciones, así como un documento oficial de compra (factura, ticket, recibo).

No se aplicará la garantía en caso de: montaje incorrecto, producción de agua caliente sanitaria inadecuada, falta de mantenimiento, uso de agua caliza, accidente o impacto, uso de productos abrasivos o corrosivos, modificación del revestimiento de la superficie original. Instalación eléctrica y sanitaria de la vivienda que no cumpla con las normas reglamentarias. El incumplimiento de las instrucciones de uso y métodos de instalación anulará la garantía.

INSTALACIÓN

En el montaje se recomienda realizarlo con al menos dos personas, para poder mantener y fijar ciertos elementos.

Los elementos de vidrio, por razones de seguridad y estándares están hechos de vidrio templado. Dado que el vidrio templado está diseñado para que en caso de rotura explote en pedazos (no produzca cortes afilados) al impactar, estos artículos deben manipularse con sumo cuidado. Por este mismo motivo, es fundamental no forzar el apriete de los accesorios a fijar en los elementos acristalados (tiradores de puerta, repisas, soporte de ducha, toallero, etc.). Puede proteger los elementos de vidrio colocándolos sobre mantas o alfombras. Nunca coloque una pieza de vidrio en plano.

LIMPIE Y MANTENGA



LIMPIEZA REGULAR :

Utilice una esponja de ducha con un detergente de pH neutro (limpiador doméstico multi superficies, líquido lavavajillas). Si es difícil eliminar la suciedad, use vinagre de alcohol blanco diluido en agua y luego enjuague con agua limpia.



LIMPIEZA DE CAL :

Use un paño suave y zumo de limón y/o vinagre de alcohol blanco tibio, luego enjuague con agua limpia. La forma más fácil de mantener limpias las paredes es usar un limpiacristales de goma. Si limpia las paredes directamente después de ducharse, minimizará la formación de cal en las superficies.



Nunca use un limpiador que contenga granos de pulido, acetona, cloro, amoníaco (lejía) o cualquier otro limpiador agresivo a base de ácido. Este tipo de productos reacciona con efectos como rayones, contra el cromo.

GARANTEE

AURLANE products are guaranteed for 2 years, spare parts only. As the labor is not carried out by us, no labor guarantee will be applied by AURLANE. In the event of a proven manufacturing defect or breakage of an element, these elements can be ordered from the distributor who sold this product, however in no case will the labor relating to the replacement of the part be taken into account charge by AURLANE.

The installation of this bath screen needs to be carried out according to the rules of the art. Our company declines all responsibility and reserves the right not to ensure its guarantee in the event that this product is not installed by qualified personnel. In the event of a request for an item under warranty, it is imperative to provide the purchase invoice for the product.

The glazed elements are wrapped in transparent film to allow the condition of these elements to be checked during purchase. No replacement of these elements will be supported by AURLANE in the event that a breakage is reported after the removal of the packages in store or during delivery the breakage of the glass is not covered by guarantee if it is not clearly indicated on the delivery note.

It is essential to check the condition of each item when unpacking. No complaint relating to the quality of the product will be taken into account after a period of 14 days after the purchase of the product. Remember to keep the manual as well as an official purchase document (invoice, receipt) for any complaint or request for spare parts.

Non-application of the guarantee: incorrect assembly, unsuitable hot water production, lack of maintenance, limestone, accident or impact, use of abrasive or corrosive products, modification of the coating of the original surface. Electrical and sanitary installation of the home not complying with regulatory standards.

Failure to follow instructions for use and installation methods will void the warranty.

INSTALLATION

The assembly must be carried out with at least two people, so as to be able to maintain and fix certain elements.

The glass elements are made of tempered glass for standards and safety reasons. As tempered glass is designed to explode into (non-sharp) pieces on impact, these items should be handled with extreme care. For this same reason, it is essential not to force the tightening of the accessories to be fixed on the glazed elements (door handles, shelves, shower holder, towel holder, etc.). You can protect the glass elements by laying them on blankets or pieces of carpet. Never place a glass part on an angle.

CLEANING & MAINTENANCE



REGULAR CLEANING :

Use a shower sponge with a neutral pH detergent (multi-surface household cleaner, dishwashing liquid). If it is difficult to remove the dirt, use white alcohol vinegar diluted with water then rinse with clear water.



LIMESTONE CLEANING :

Use a soft cloth and lemon juice and/or warm white alcohol vinegar then rinse with clear water. The easiest way to keep your walk in shower stall clean is to use a squeegee. If you wipe the glass directly after taking a shower, you will minimize the formation of limescale on the surfaces.



Never use a cleaner containing polishing grains, acetone, chlorine, ammonia (bleach) or any other aggressive acid-based cleaner. This type of products reacts with effects like scratches, against chrome.

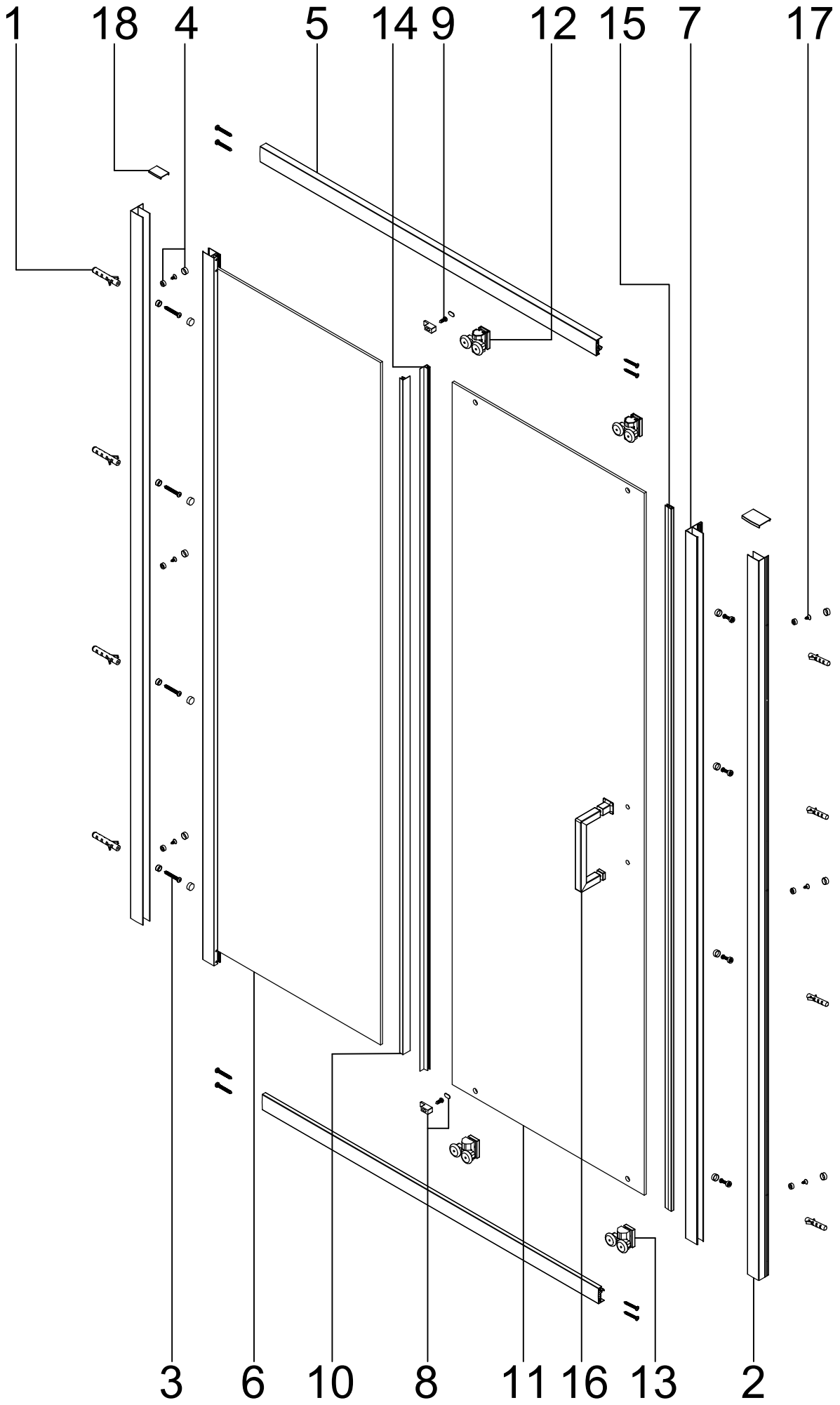

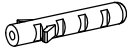
1 AURL967

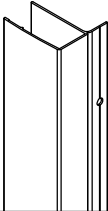
X8

2 AURL1928

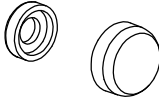
X2

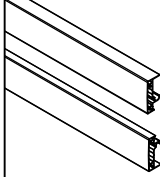
3 AURL968

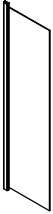
ST3.9X35 X16

4 AURL1720

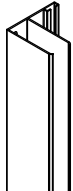
X14

5

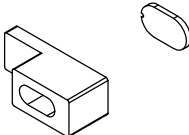
X1

6

X1

7 AURL1934

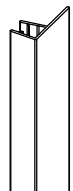
X1

8 AURL1935

X2

9 AURL1083

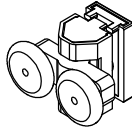
ST3.9X13 X2

10

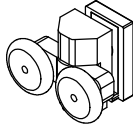
X1

11

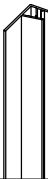
X1

12 AURL1937

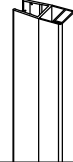
X2

13 AURL1936

X2

14

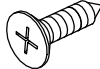
X1

15

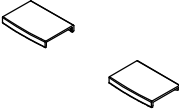
X1

16 AURL1930

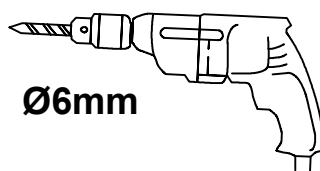
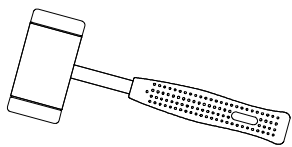
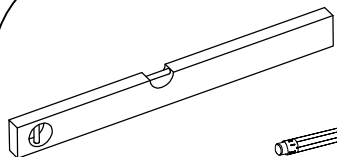
X1

17 AURL991

ST4X10 X6

18 AURL1932

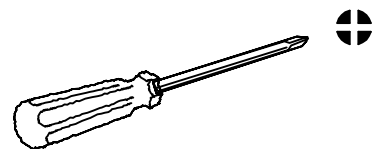
X1



Ø6mm

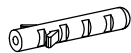

1



X8

2

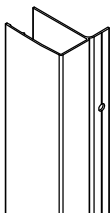

X2

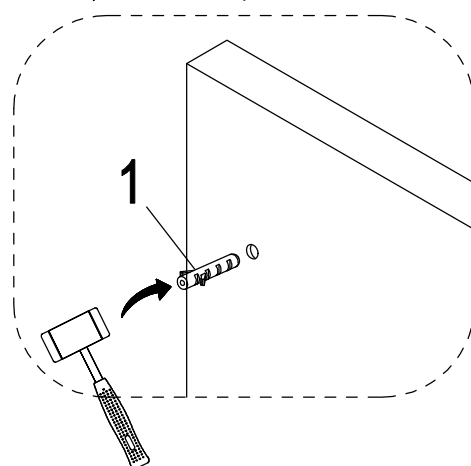
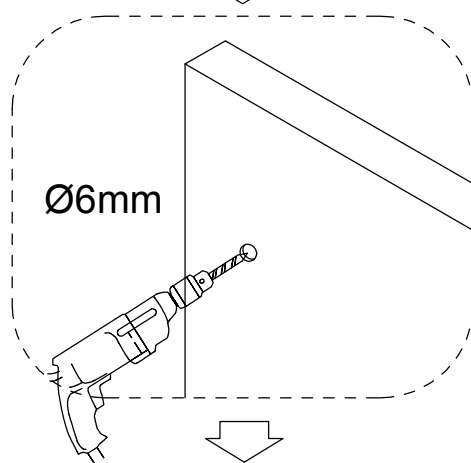
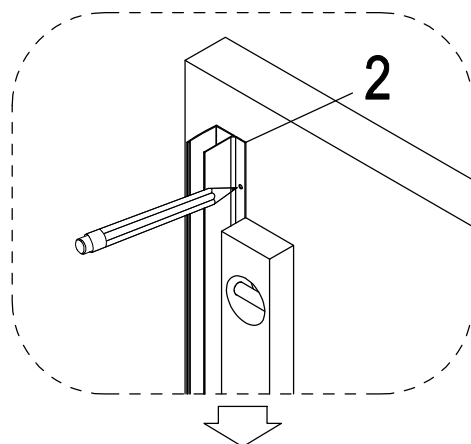
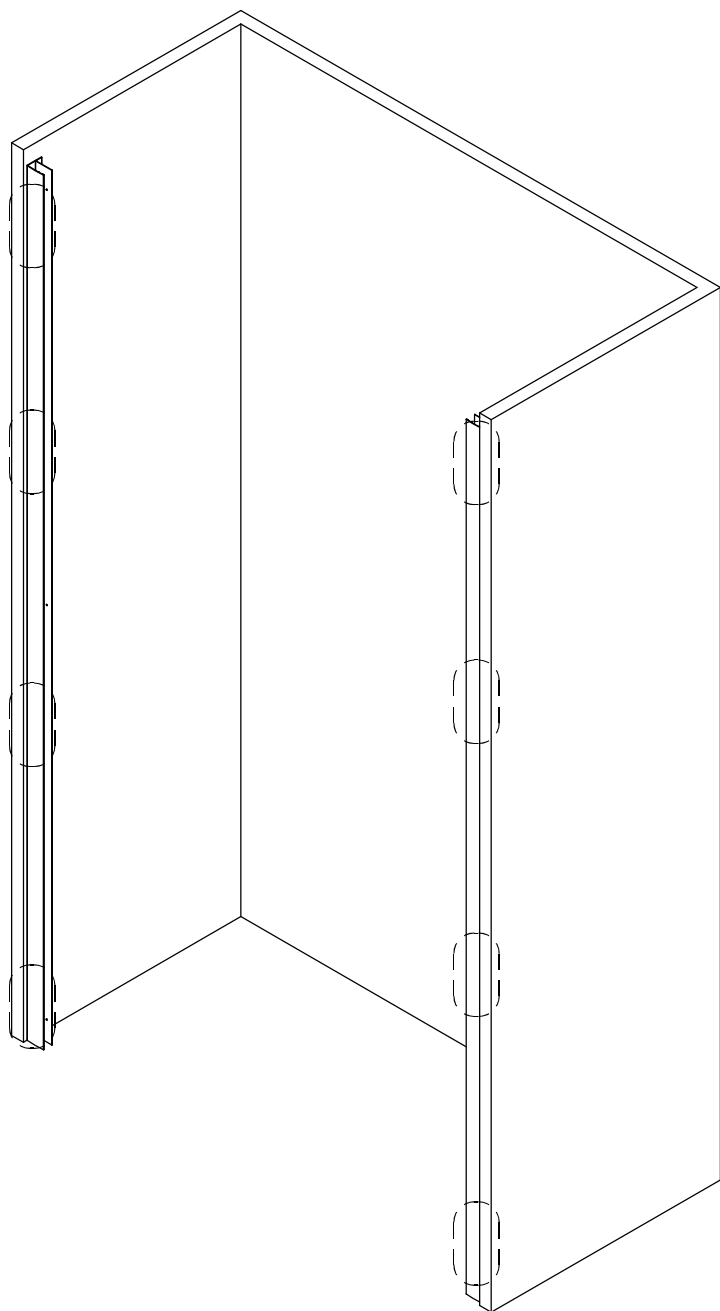

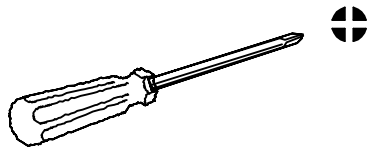

3



ST3.9X35

X4

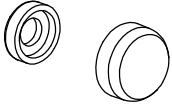

4

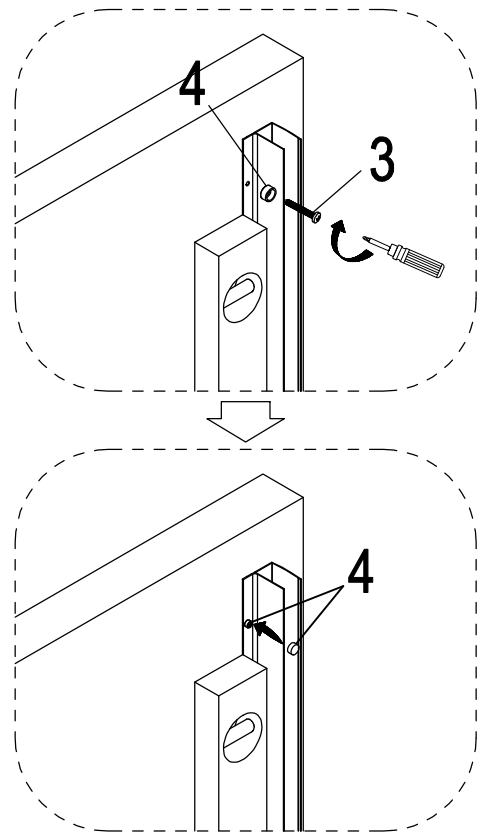
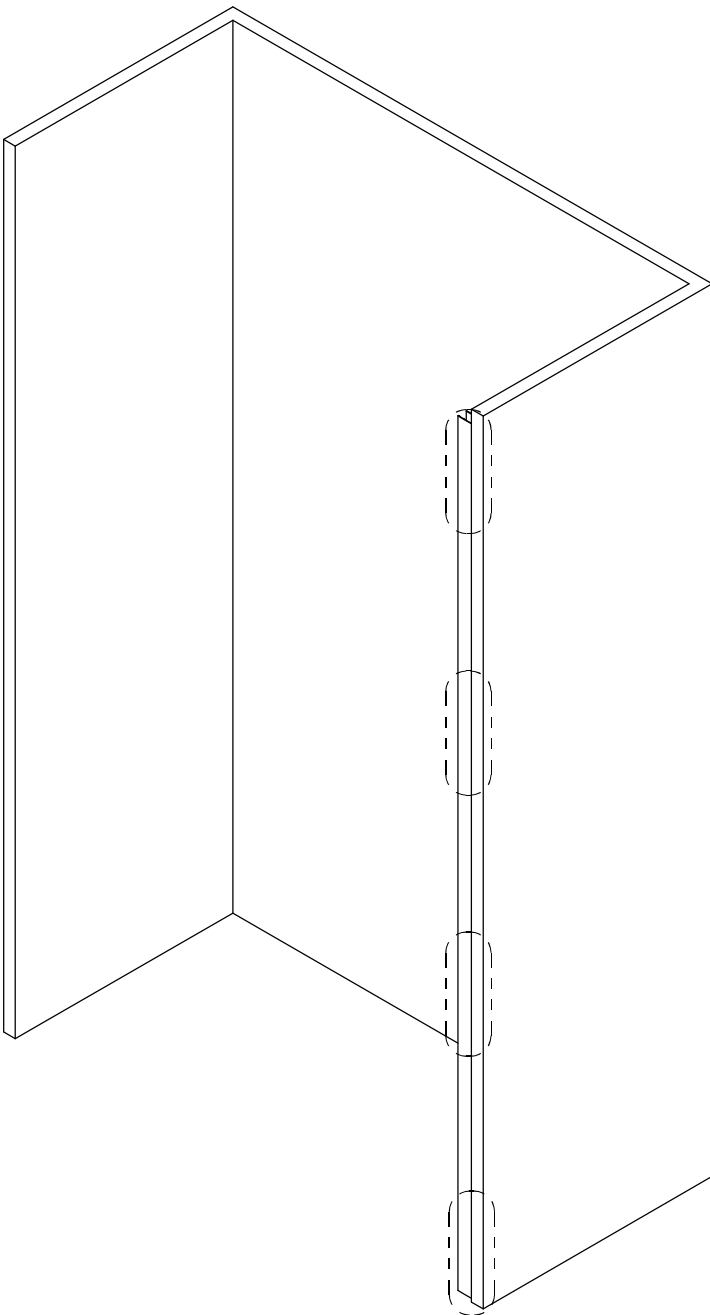

X4

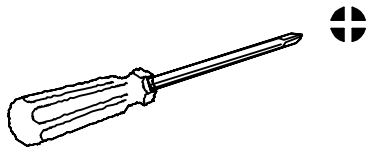

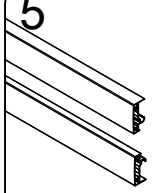
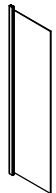
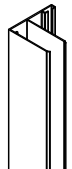
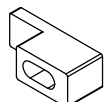

- | | | | | | |
|--|--|--|--|--|--|
| <p>3</p>  <p>ST3.9X35</p> <p>X8</p> | <p>5</p>  <p>X1</p> | <p>6</p>  <p>X1</p> | <p>7</p>  <p>X1</p> | <p>8</p>   <p>X2</p> | <p>9</p>  <p>ST3.9X13</p> <p>X2</p> |
|--|--|--|--|--|--|

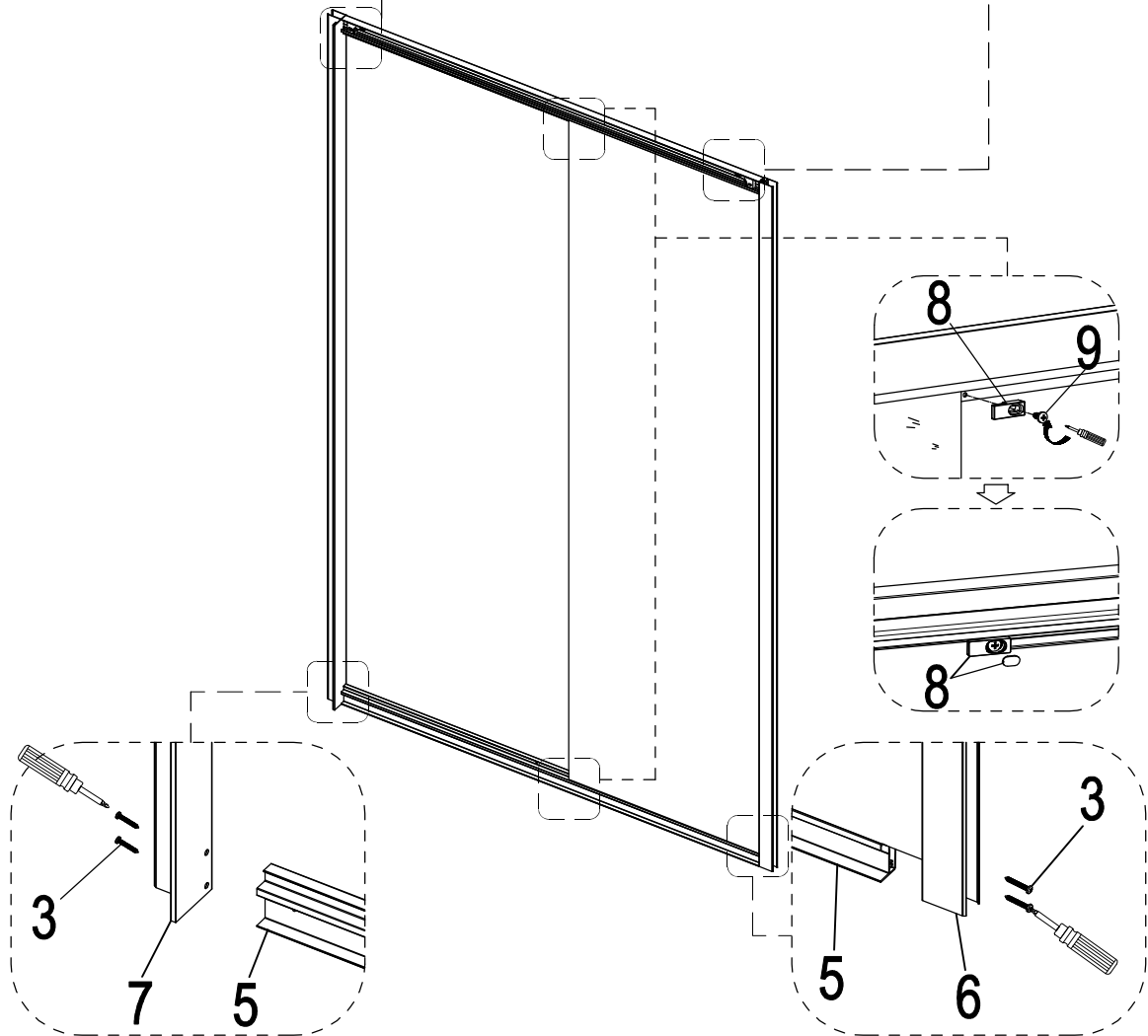
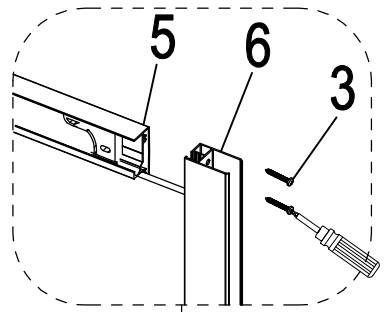
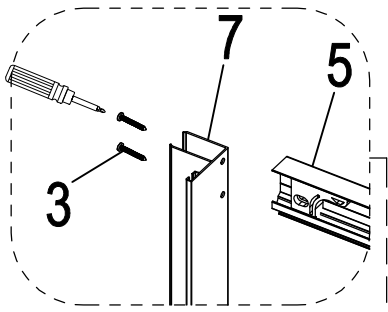

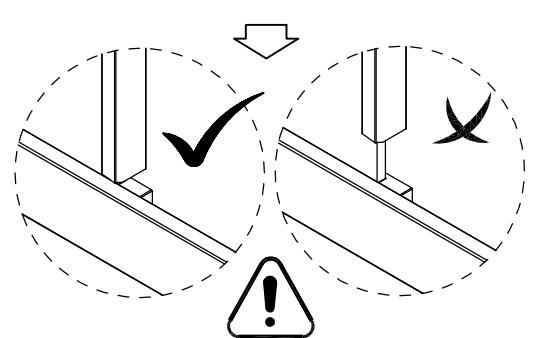
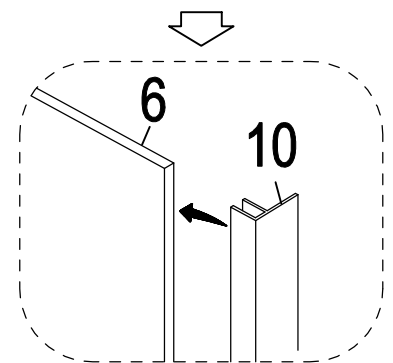
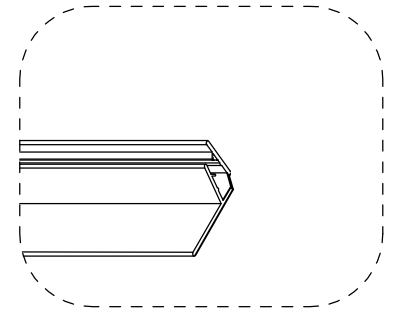
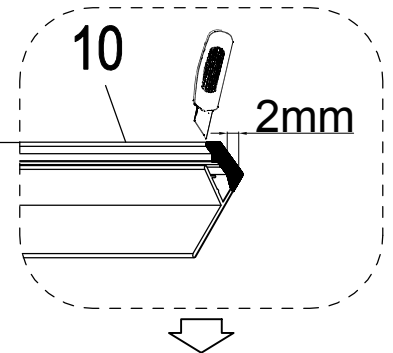
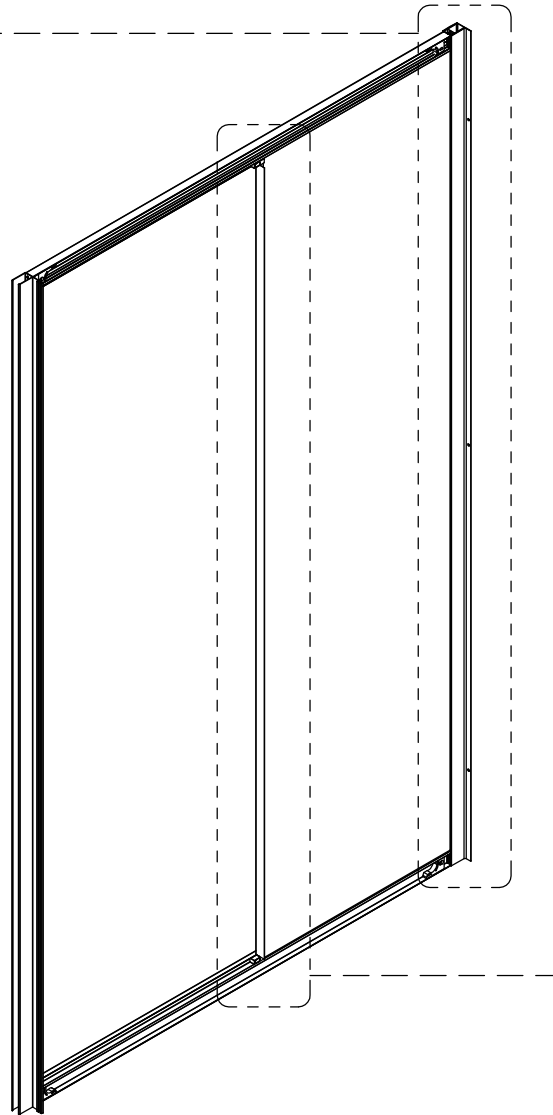
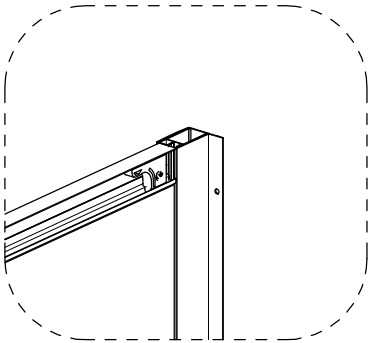
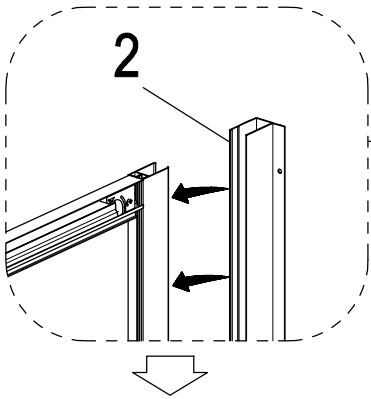
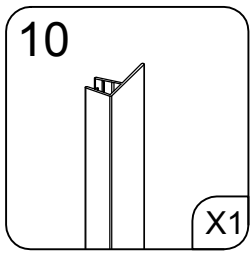
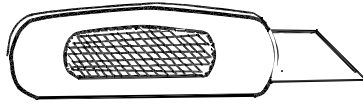

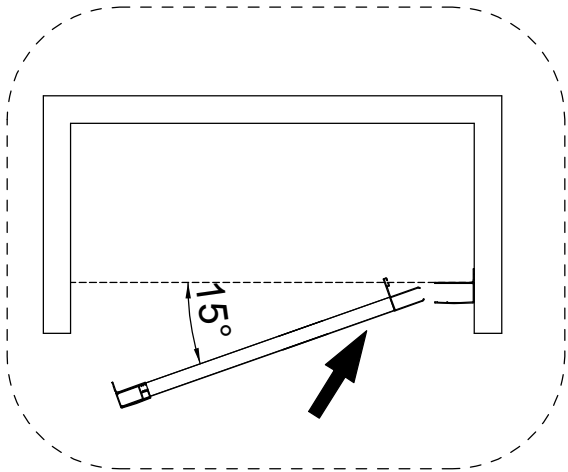
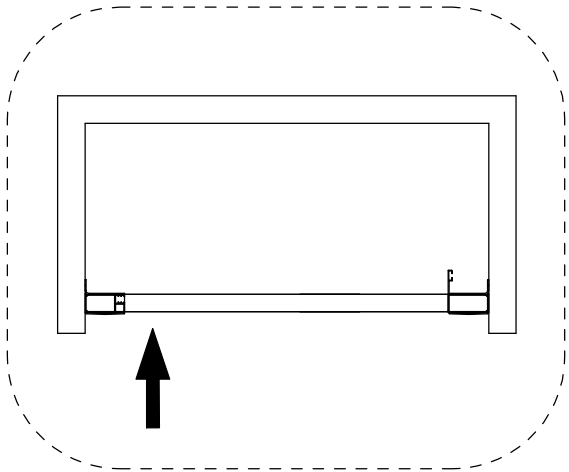
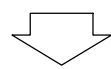
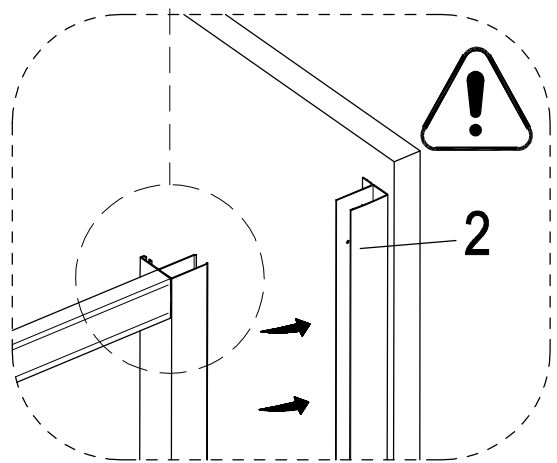
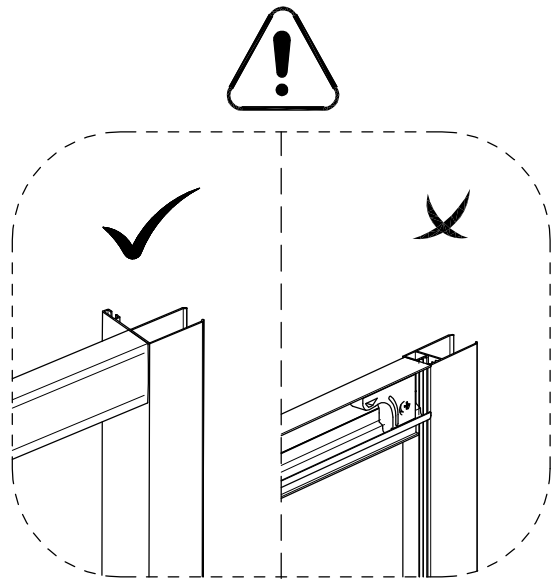
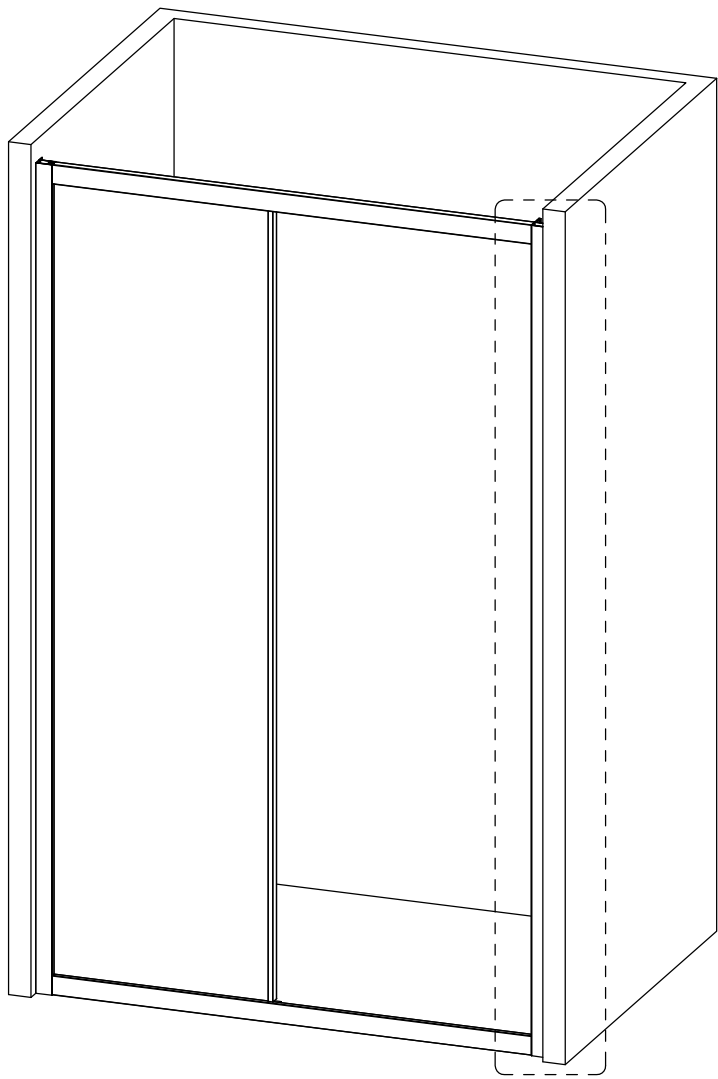

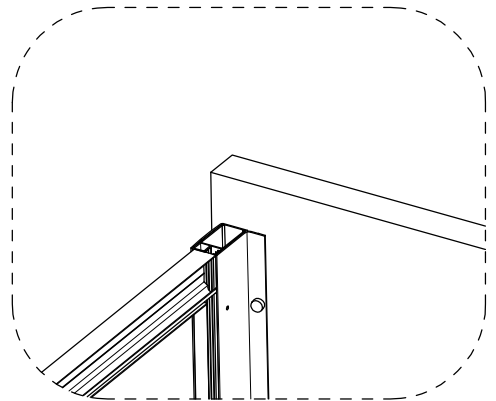
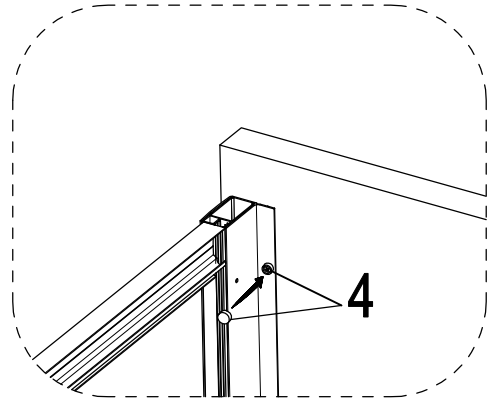
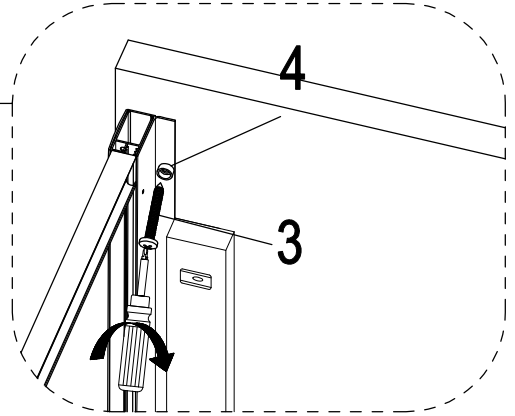
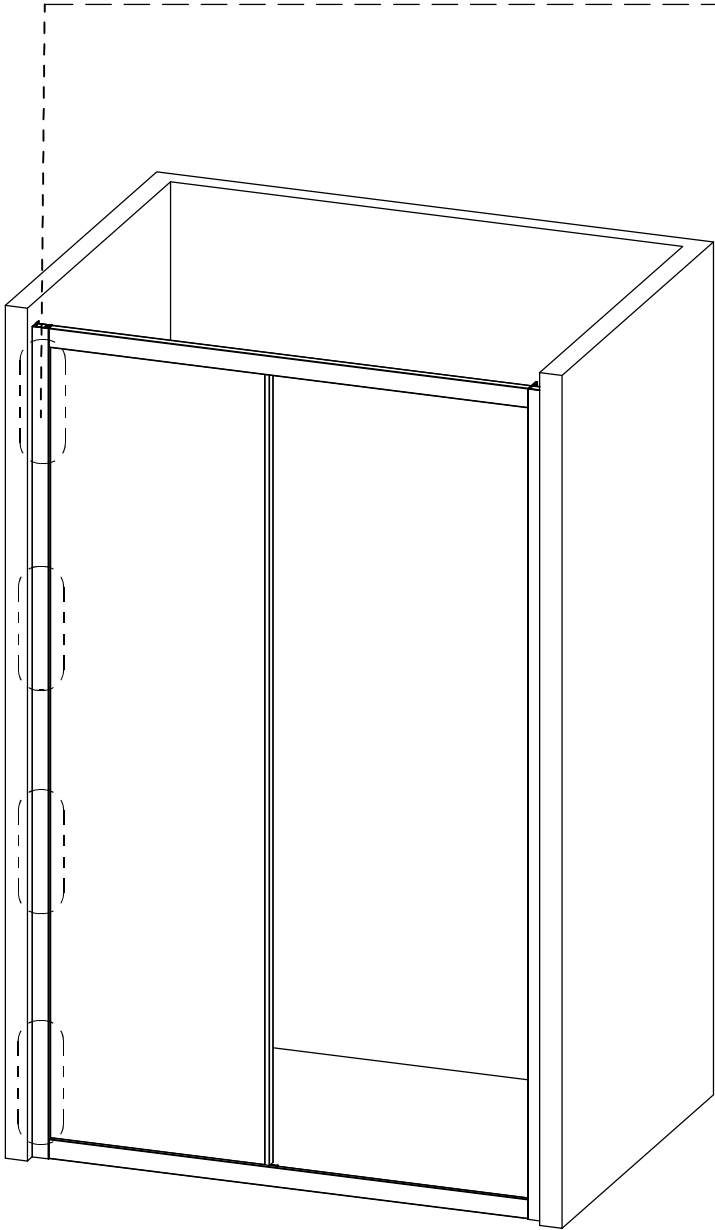
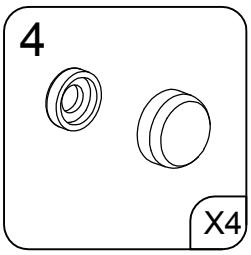
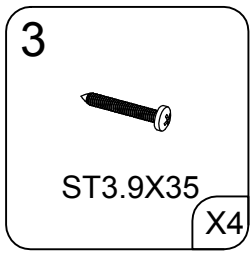
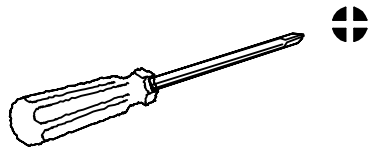

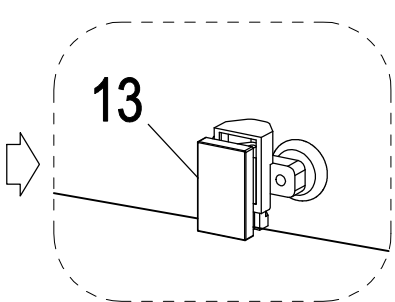
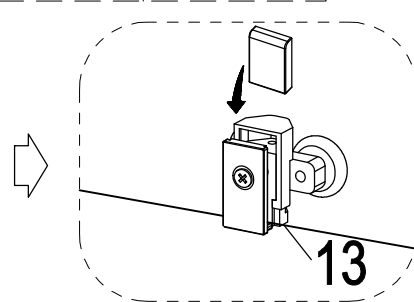
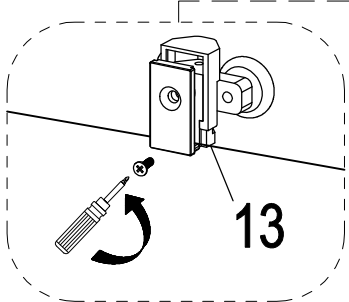
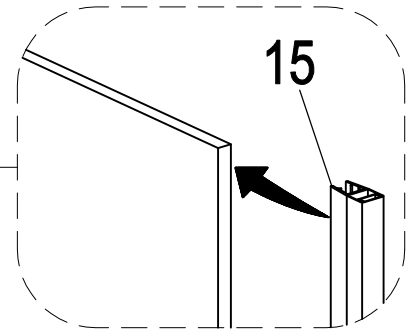
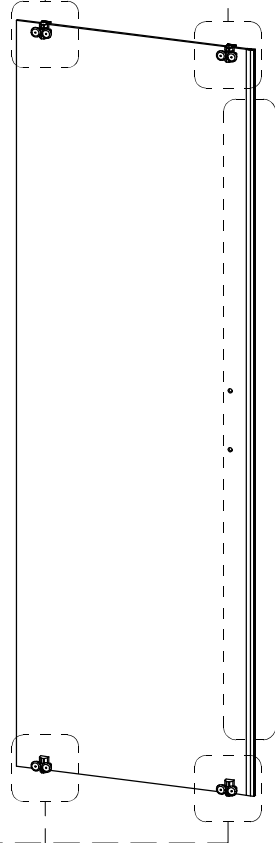
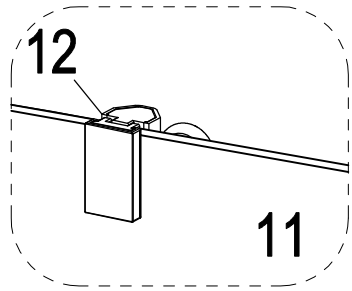
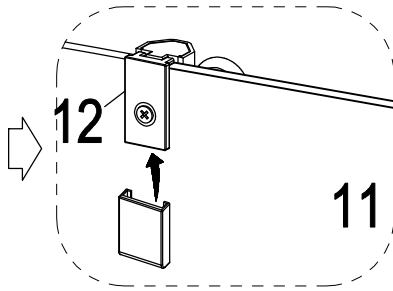
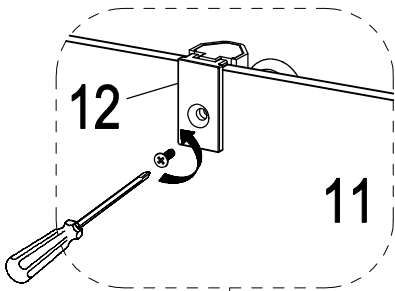
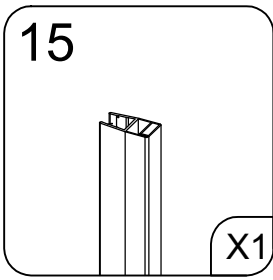
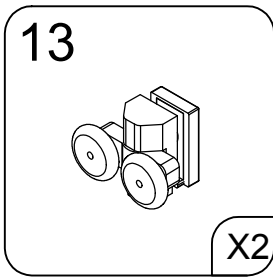
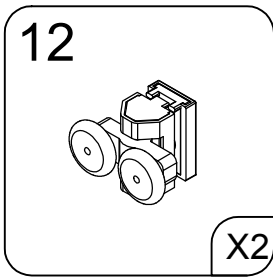
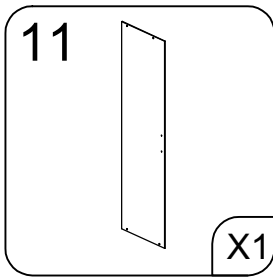
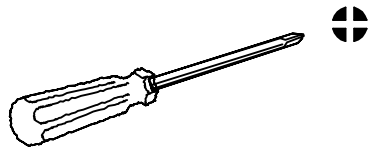

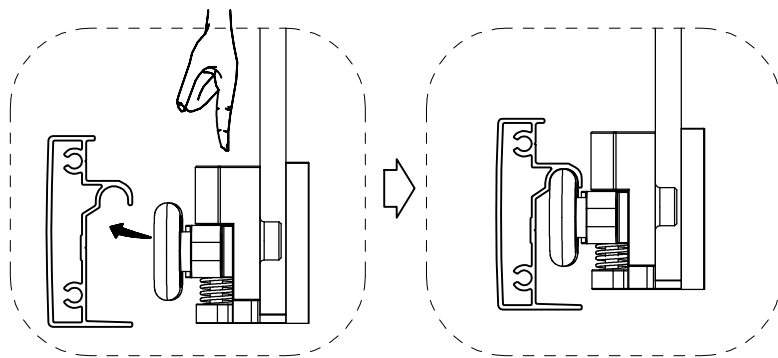
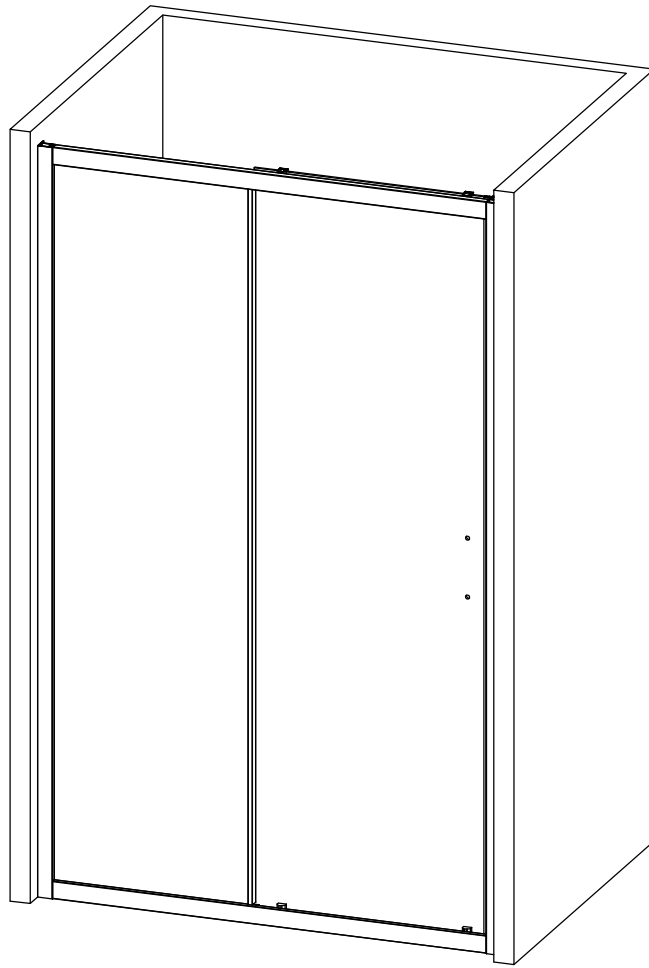
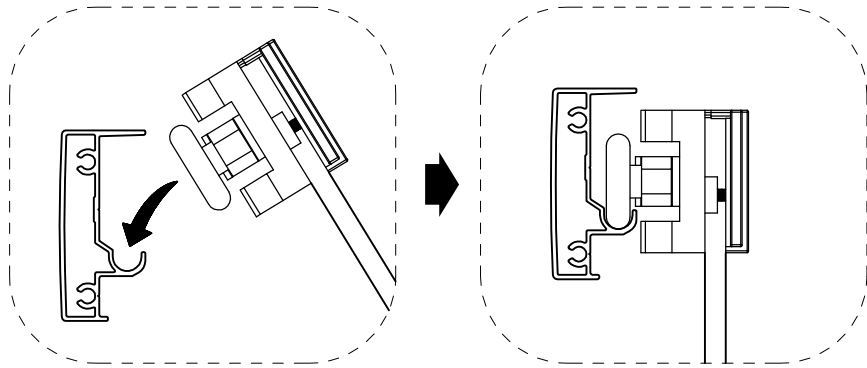

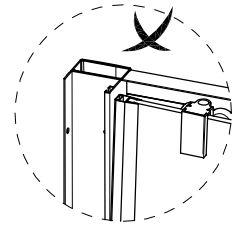
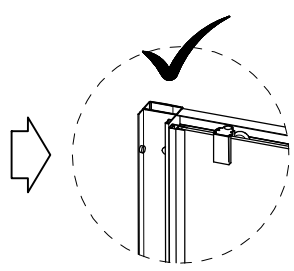
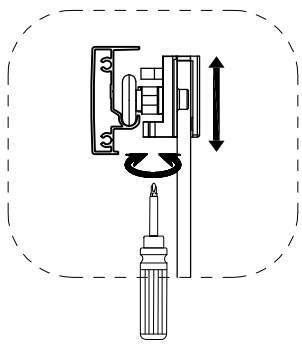
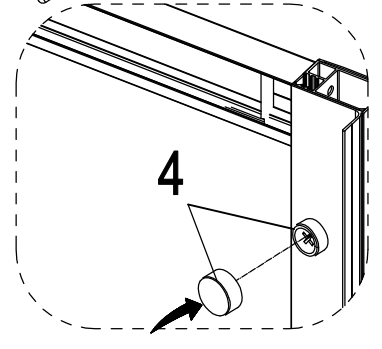
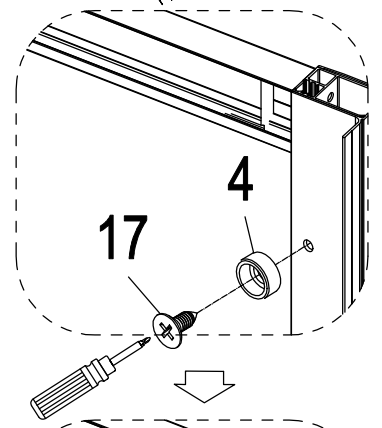
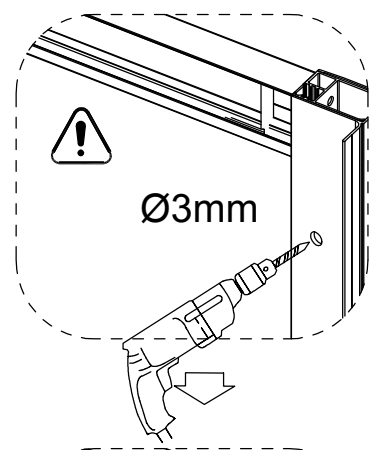
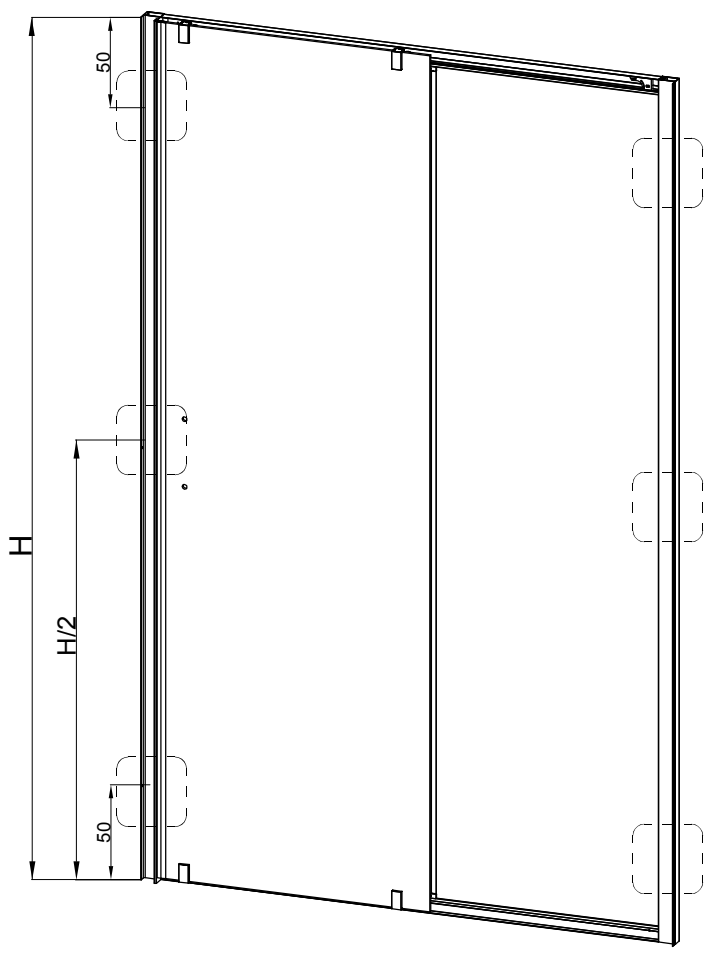
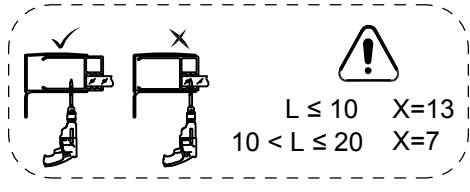
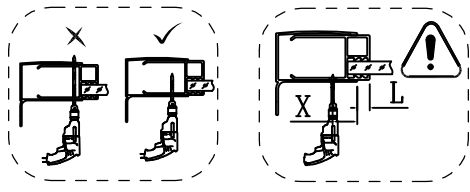
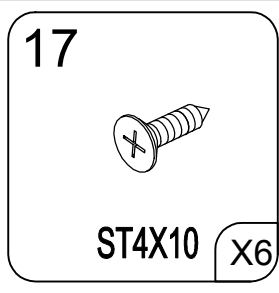
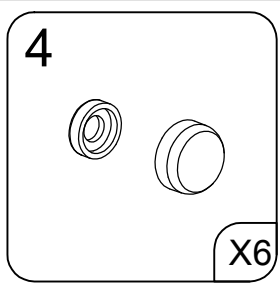
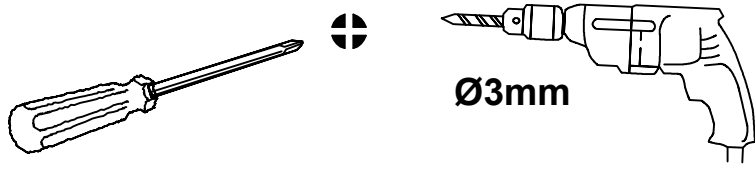

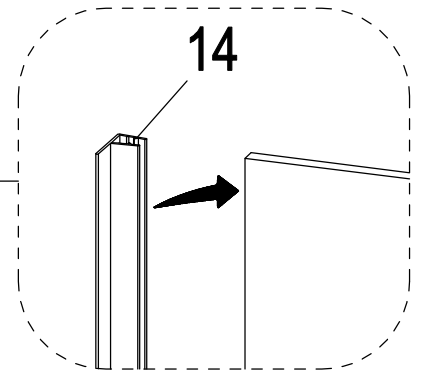
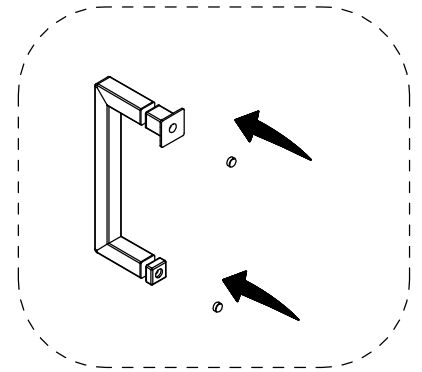
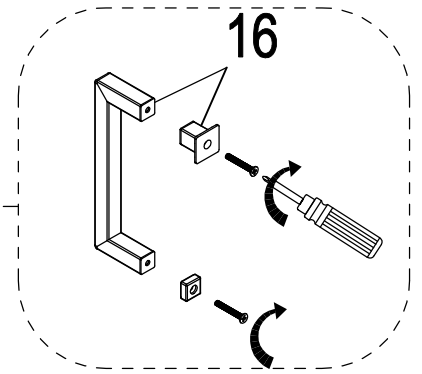
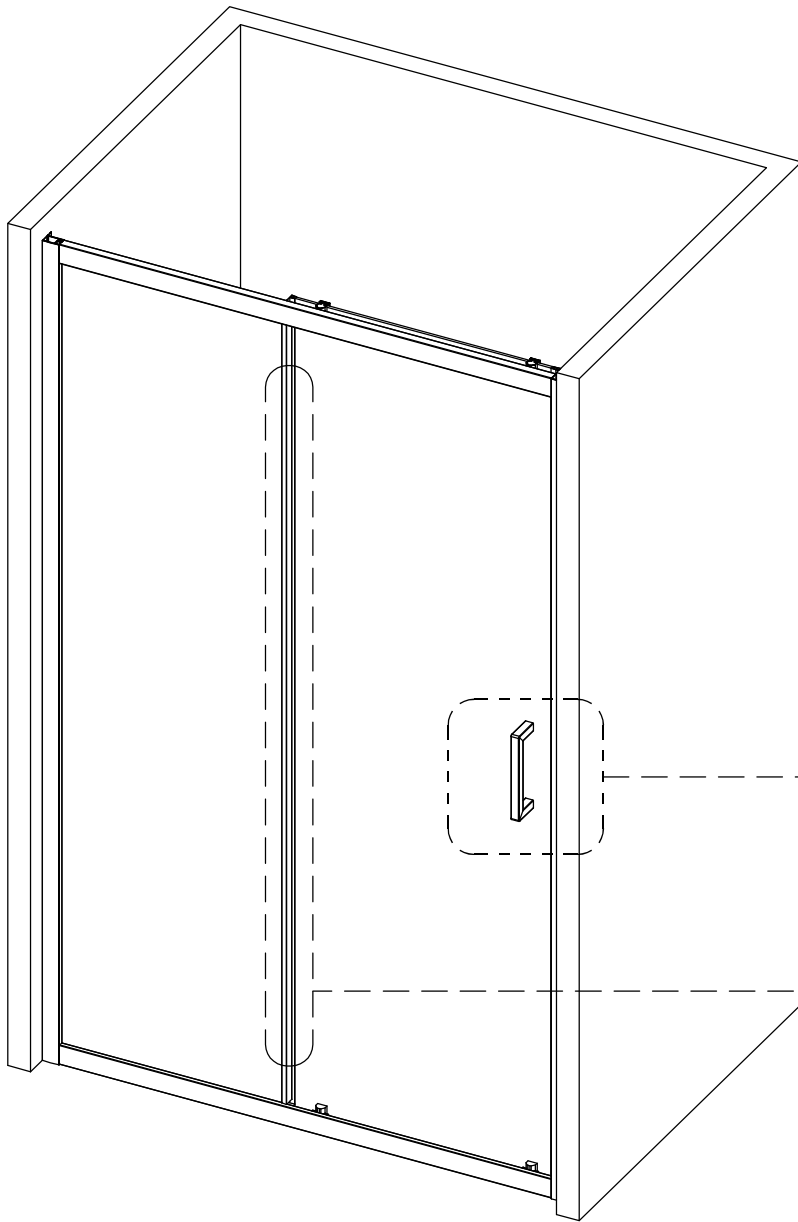
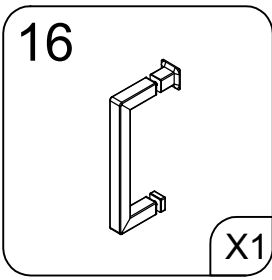
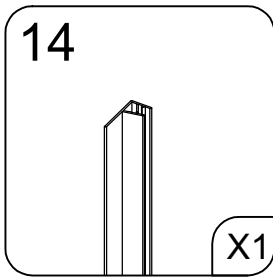
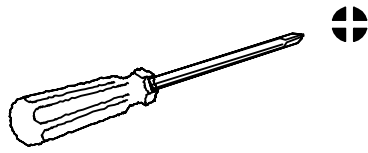

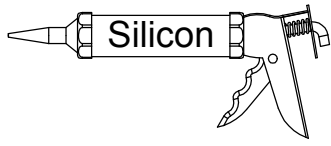

18



X1

