

50-85"
XL 127-216cm

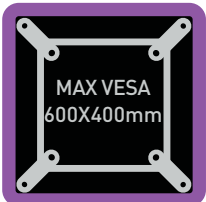

NEO protective pads: Our specially engineered NEO pads protect your TV from unwanted marks and scratches and also act as an extra layer of audio insulation preventing resonance and vibration from your speaker system from affecting your TV.

6-Arm Cantilever: The ultimate in stability two sets of triple arms combine to deliver silky smooth movement and top grade rigidity. Strong, stable and smooth every time its repositioned.

Shaped Arms: Concave shaped arms, precision designed by our experienced design team to deliver the best, strongest and most stable performance.

Spirit Level: Comes with an integrated spirit level to make installation accurate and more convinient.

Longer Reach: Extended arms allow for this mount to have a longer reach than regular mounts. Comes out even furtehr from the wall to give you even more viewing options.

Quick adjust lever: Raise the lever, adjust the tilt to the desired position then press the lever down. Simple and effortless allowing you to find the perfect viewing angle every time.

Safety pull cord lock: The mount locks solidly into place with spring clips for safety and peace of mind. Pull cords are supplied to open the clips allowing for easy removal of TV if required.

Vesa Extender Plates: Your mount functions in standard 200 VESA mode or add the included VESA extender plates to take it all the way up to 400 VESA for extra TV compatibility.

Multi colour design language: The new TV you just purchased is a work of art with or without a picture on the screen, Now your mount can be just as much a design feature as the TV its connected to!

5 Year Warranty: Our mounts are built to last. Each one comes with a 5 year warranty as standard.

Quality Construction: Made with the highest quality components and over a decade of experience.



Technical Specifications:

Max Load	Distance from wall (Folded)	Distance from wall (Extended)	Swivel Range	Tilt Range	No of Articulation Points	Mounting Pattern	VESA Compatible
50Kg/ 110lbs	110mm/ 2.9"	633 24.9"	±65°	±15°	6	Double Stud & Solid Wall	100x100 to 600x400



Packed image



Line drawing

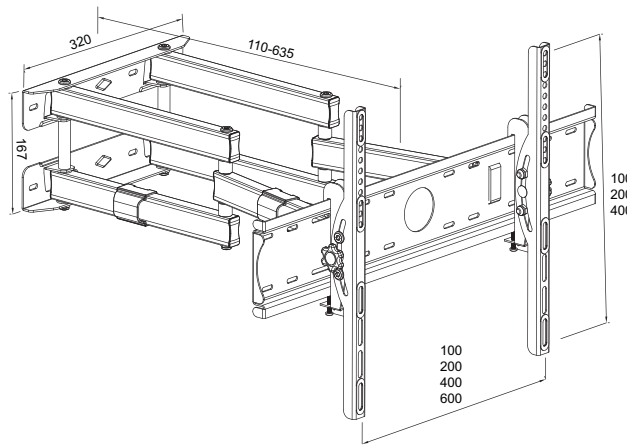

All dimensions are in mm

Packaging Information:

Product Number	Description	Product Packaging		Outer Packaging		
		Type	Barcode	Type	Qty in Box	Barcode
LN2RFM600XL-RO	XL Six Arm Cantilever Full Motion TV Wall Mount	Colour Gift Box	5015056591896	Brown Outer with Label	2	5015056544496

Weight & Dimensions:

Product			Product Box			Outer Box		
Extended	Folded	Net Weight	Dimensions	Gross Weight	Cubic	Dimensions	Gross Weight	Cubic
66.8 x 43 x 63.3 cm	66.8 x 43 x 11 cm	6.95kg	85 x 24.5 x 7 cm	7.69kg	0.0146m ³	87 x 26 x 16.5 cm	16.38kg	0.0373m ³
26.30" x 16.93" x 24.92"	26.30" x 16.93" x 4.33"	15.29lbs	33.46" x 9.65" x 2.76"	16.918lbs	0.5148ft ³	34.25" x 10.24" x 6.50"	36.036lbs	1.3180ft ³