

45 min

EN Safety instructions  
DE Sicherheitsanweisungen

The assembly must be carried out by 2 persons.  
Die Montage muss von 2 Personen ausgeführt werden.

Use work gloves for assembly! To avoid scratches, use suitable supports!  
Nutzen Sie Arbeitshandschuhe bei der Montage. Um Kratzer zu vermeiden, nutzen Sie eine geeignete Unterlage!

Do not install any damaged parts! If you find any damage, this must be reported to us in advance, including meaningful pictures. The parts are considered as accepted by the installation.  
Instillieren Sie keine beschädigten Teile. Wenn Sie Beschädigungen feststellen müssen diese mit aussagekräftigen Fotos an uns gemeldet werden. Verbaute Teile gelten als akzeptiert.

Tighten the screw connections only at the end of the assembly!  
Ziehen Sie die Schraubverbindungen erst nach der Montage fest!

Ensure storm-proof ground anchoring and lock the doors! Do not set up in windy conditions!  
Sorgen Sie für eine sturmsichere Bodenverankerung und schließen Sie die Türen immer ab! Nicht bei Wind aufstellen!

Keep all small parts and packaging materials away from small children during assembly. Components have sharp edges or protrude, pay attention during assembly and daily use.  
Halten Sie Kleinteile und Verpackungsmaterial während der Montage von Kindern fern. Bauteile haben scharfe Kanten oder ragen heraus, achten Sie bei der Montage und im täglichen Gebrauch darauf.

In summer, very high temperatures can arise in the interior!  
Im Sommer können im Innenraum sehr hohe Temperaturen auftreten!

Do not store aggressive chemicals such as chlorine or road salt! Remove suntan lotion and other creams with soap and water! Do not use abrasive cleaning agents! Oil the lock and hinges annually!

Lagern Sie keine aggressiven Chemikalien wie Chlor oder Streusalz! Entfernen Sie Sonnenmilch und andere Cremes mit Wasser und Seife! Verwenden Sie keine scheuernden Reinigungsmittel! Ölen Sie das Schloss und die Scharniere jährlich!

Do not use a cover or sleeve for the product.

Verwenden Sie keine Abdeckung oder Hülle für das Produkt.

The product is only suitable for mounting on a suitable, solid underground of asphalt or concrete.

Das Produkt ist nur für die Montage auf einem geeigneten, festen Untergrund aus Asphalt oder Beton geeignet.

The product is not suitable for transport in the assembled state, it must be assembled at the installation site to avoid transport damage.

Das Produkt ist nicht für den Transport im zusammengebauten Zustand geeignet, es muss am Aufstellungsort zusammengebaut werden, um Transportschaden zu vermeiden.

The product is only suitable for plastic waste containers with rubber castors. The use of other containers may void the warranty.









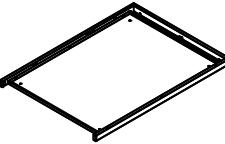
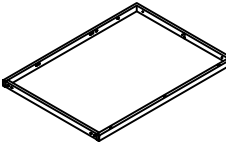
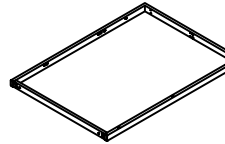
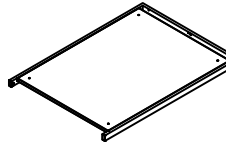
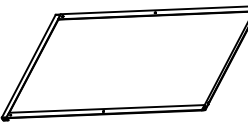
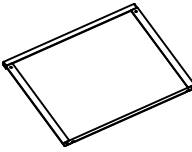
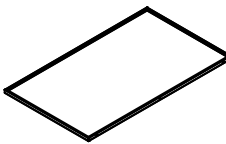
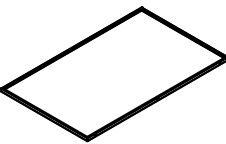
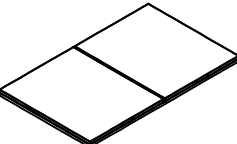
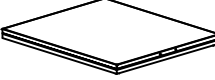
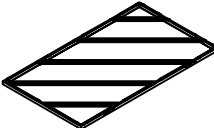
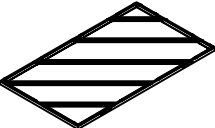

Das Produkt ist nur für Kunststoffabfallehälter mit Gummirädern geeignet. Die Verwendung anderer Behälter kann zum Erlöschen der Garantie führen.

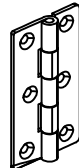
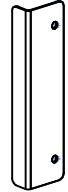
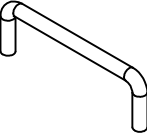
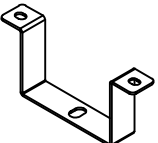
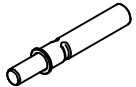
Please note that any modifications or alterations to the product will void the warranty.

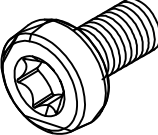
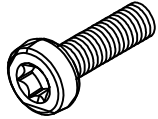
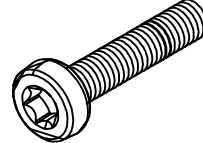
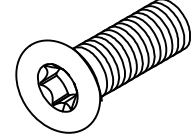
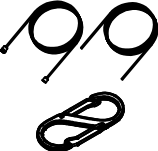
Bitte beachten Sie, dass jegliche Änderungen oder Modifikationen am Produkt zum Erlöschen der Garantie führen.

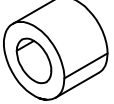
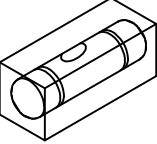
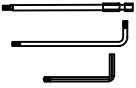
**IMPORTANT: THE ASSEMBLED COMPLETE CONSTRUCTION MUST NOT BE MOVED / PULLED / TRANSPORTED!**

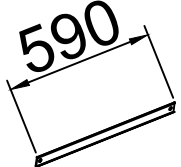
**WICHTIG: DIE AUFGEBAUTE GESAMTKONSTRUKTION DARF NICHT BEWEGT, GEZOGEN ODER TRANSPORTIERT WERDEN!**

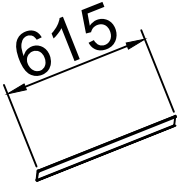
Ax1 ① 	Bx1 ② 	Cx1 ② 	Dx1 ① 	Gx1 ③ 	Fx1 ① 	Ex2 ②③  1014*598*20mm	A1x1 ②  1014*623*20mm
Ix1 ③ 	Jx1 ① 	Hx2 ②③  1014*580*22mm	Lx1 ②  1014*605*22mm	I1x6 ① 	Kx6 ① 	Mx3 ① 	Nx3 ① 
Ox3 ① 	Px6 ① 	Qx8 ① 	Rx36 ①  M4x10mm	Sx10 ①  M4x20mm	Tx15 ①  M4x30mm	Ux50 ①  M4x14mm	Vx3 ① 
Wx4 ① 	Xx4 ① 	Yx1 ① 	Zx1 ① 	W1x4 ① 	X1x2 ①  590	Y1x6 ① 	Z1x33 ①  4.3x9x0.8mm
C1x1 ①  615							

# STEP1

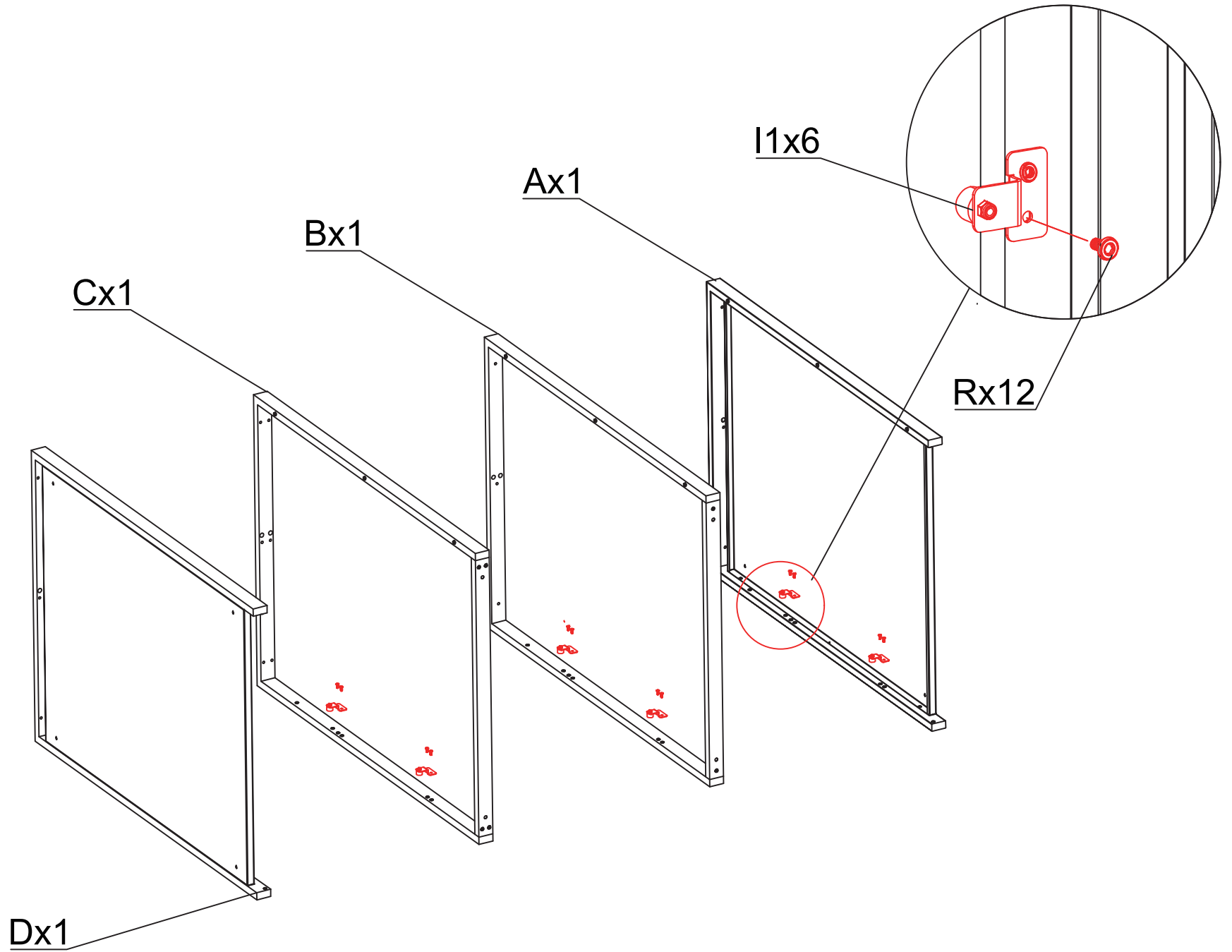

# STEP 2

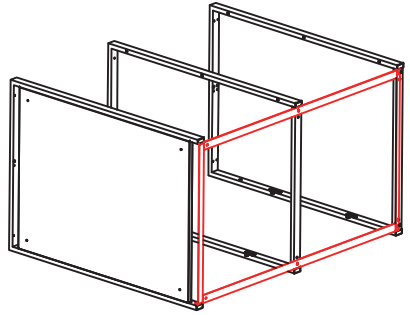

Bx1

Cx1

Ax1

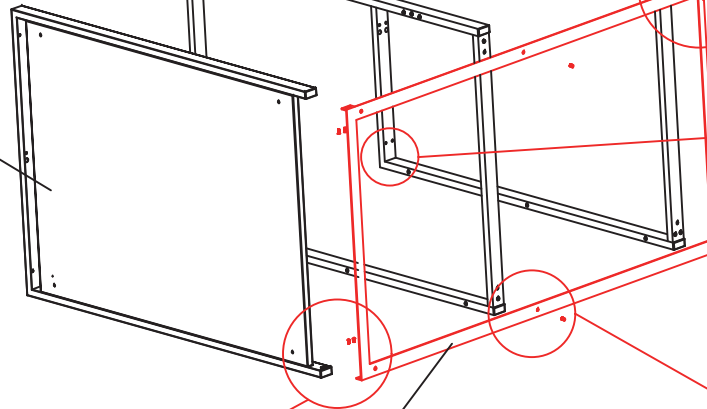

Ux2

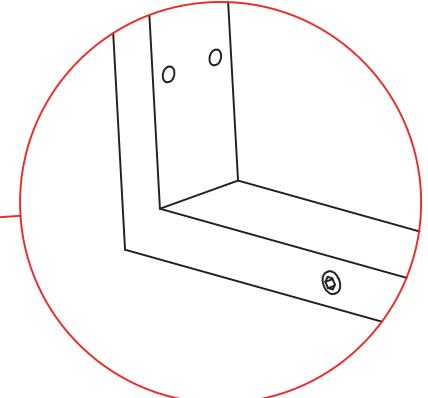
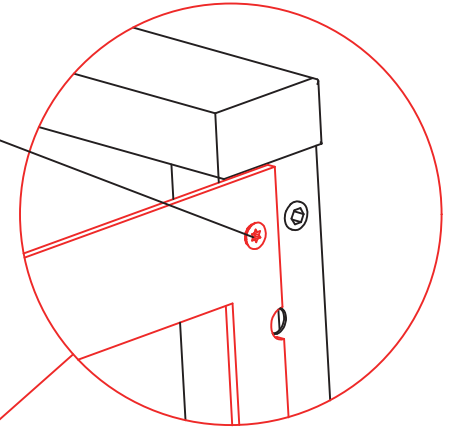

A

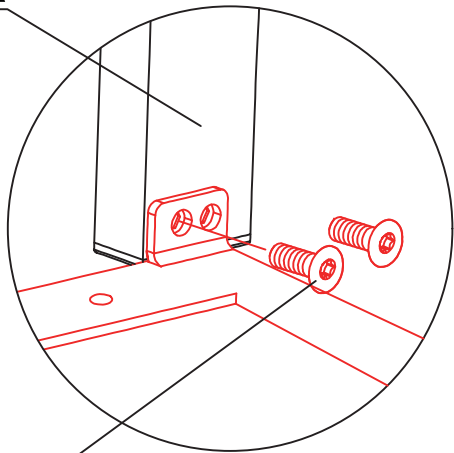

Ux4

Gx1

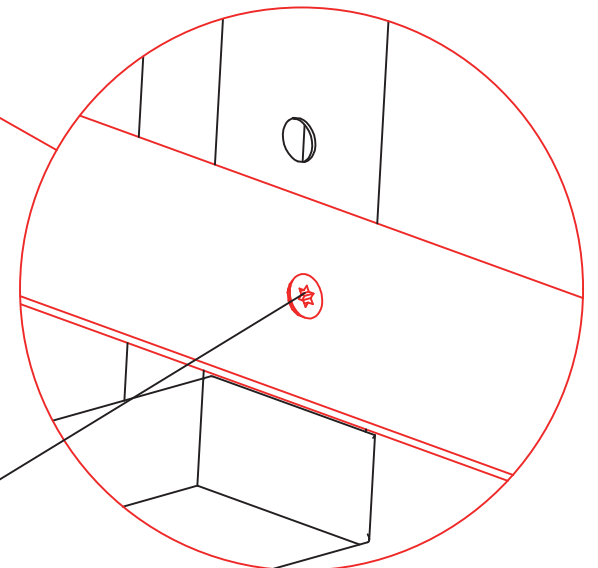

Ux2

# STEP3

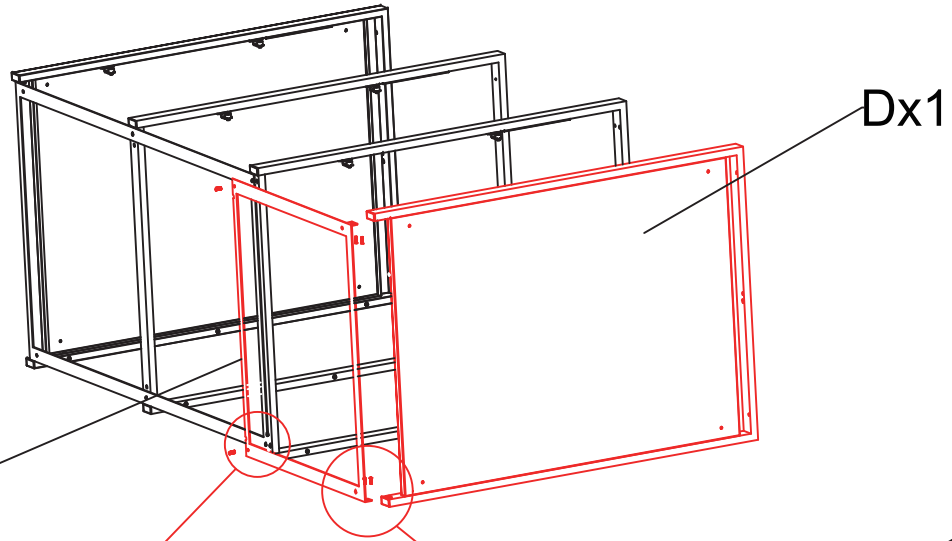
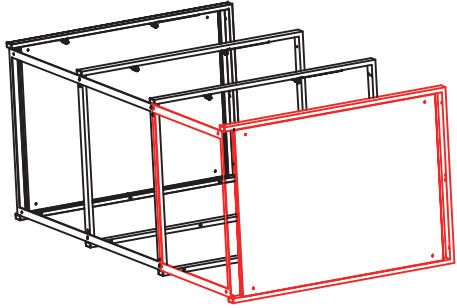

Ux2

Fx1

Dx1

D

Ux4

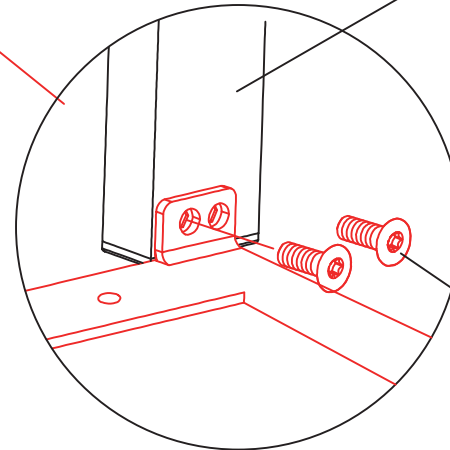
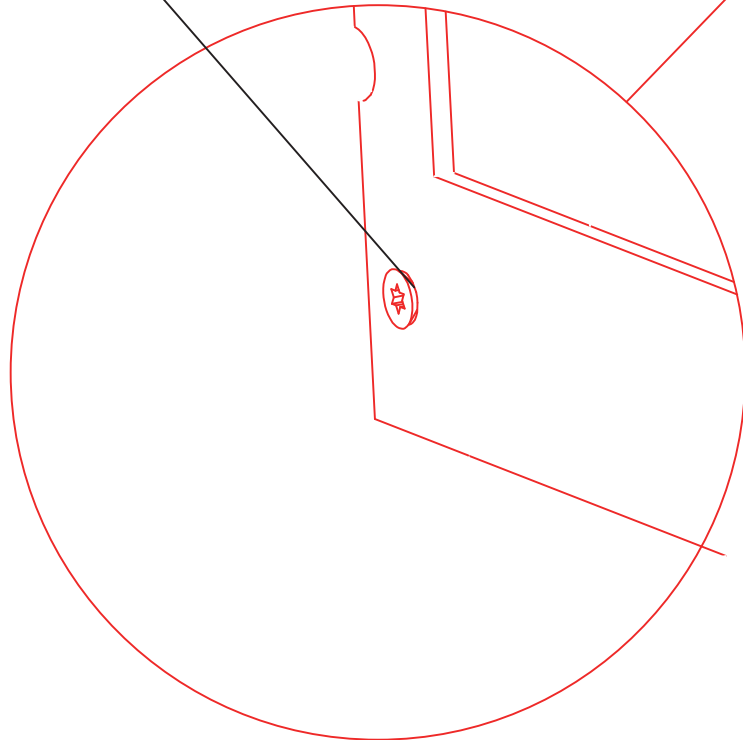

# STEP4

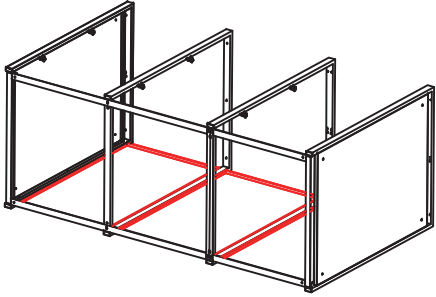

Z1x18

Rx18

E&A1

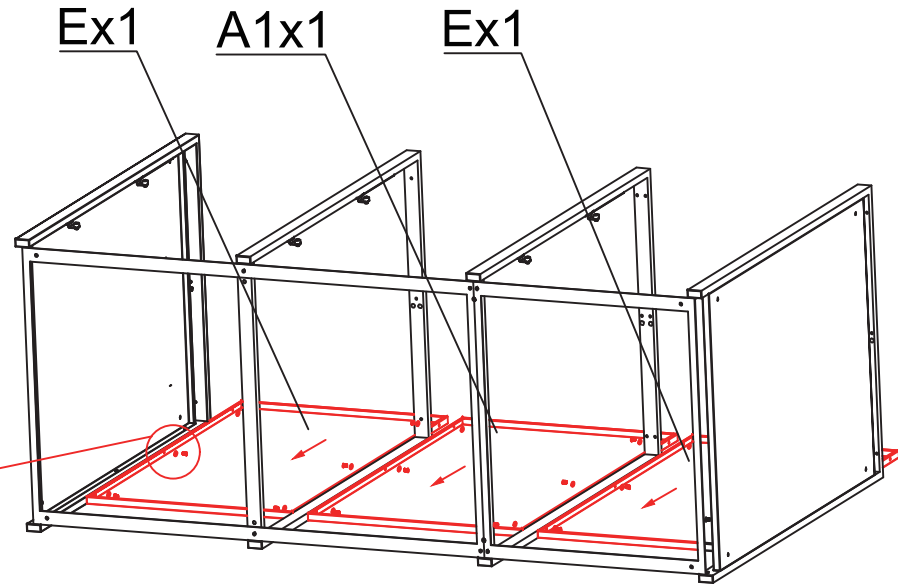
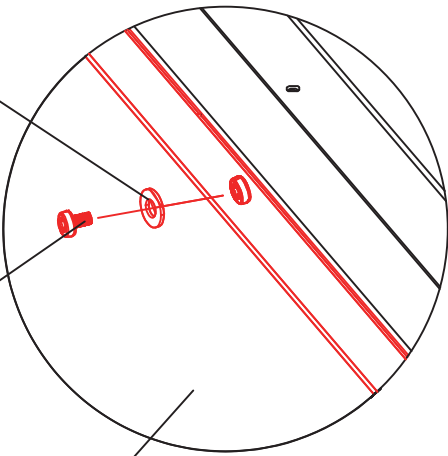

# STEP 5

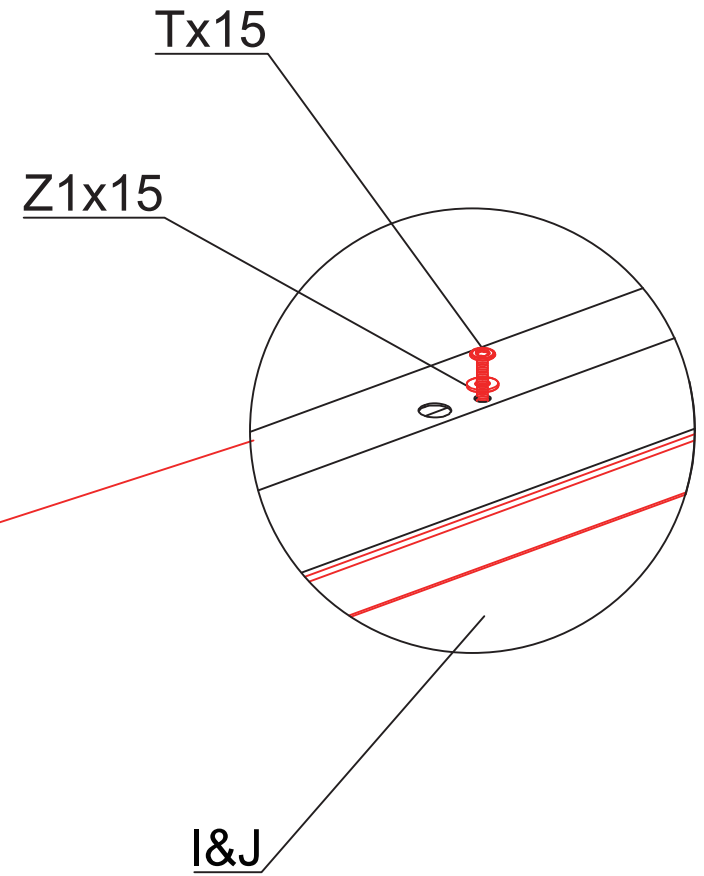
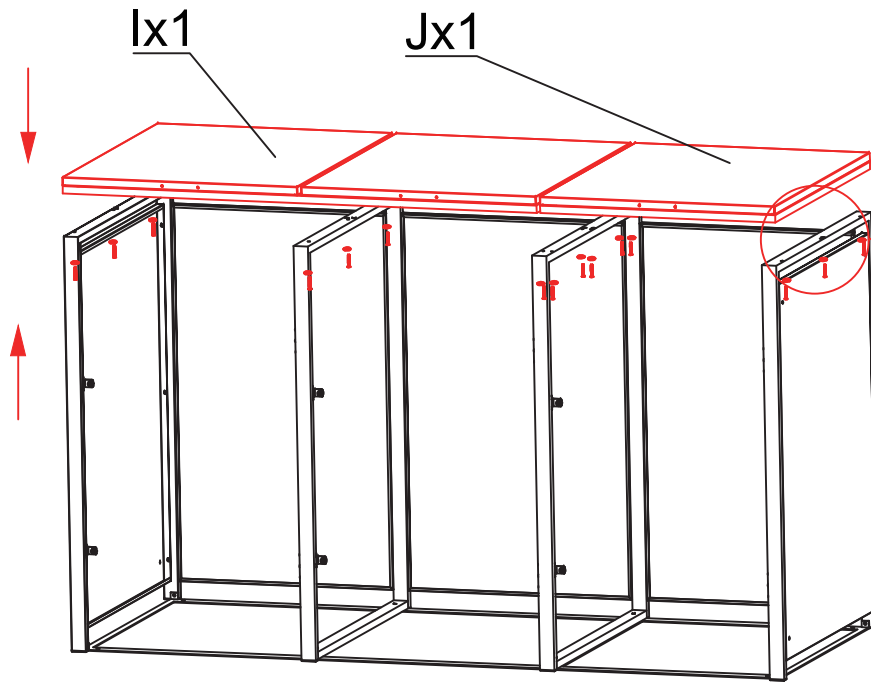
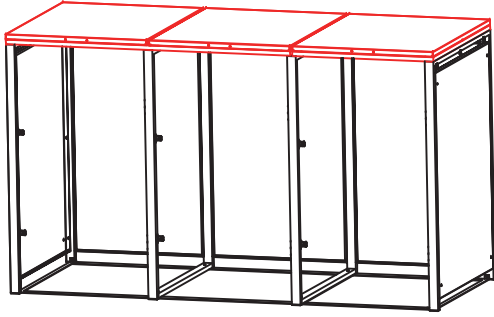

# STEP6

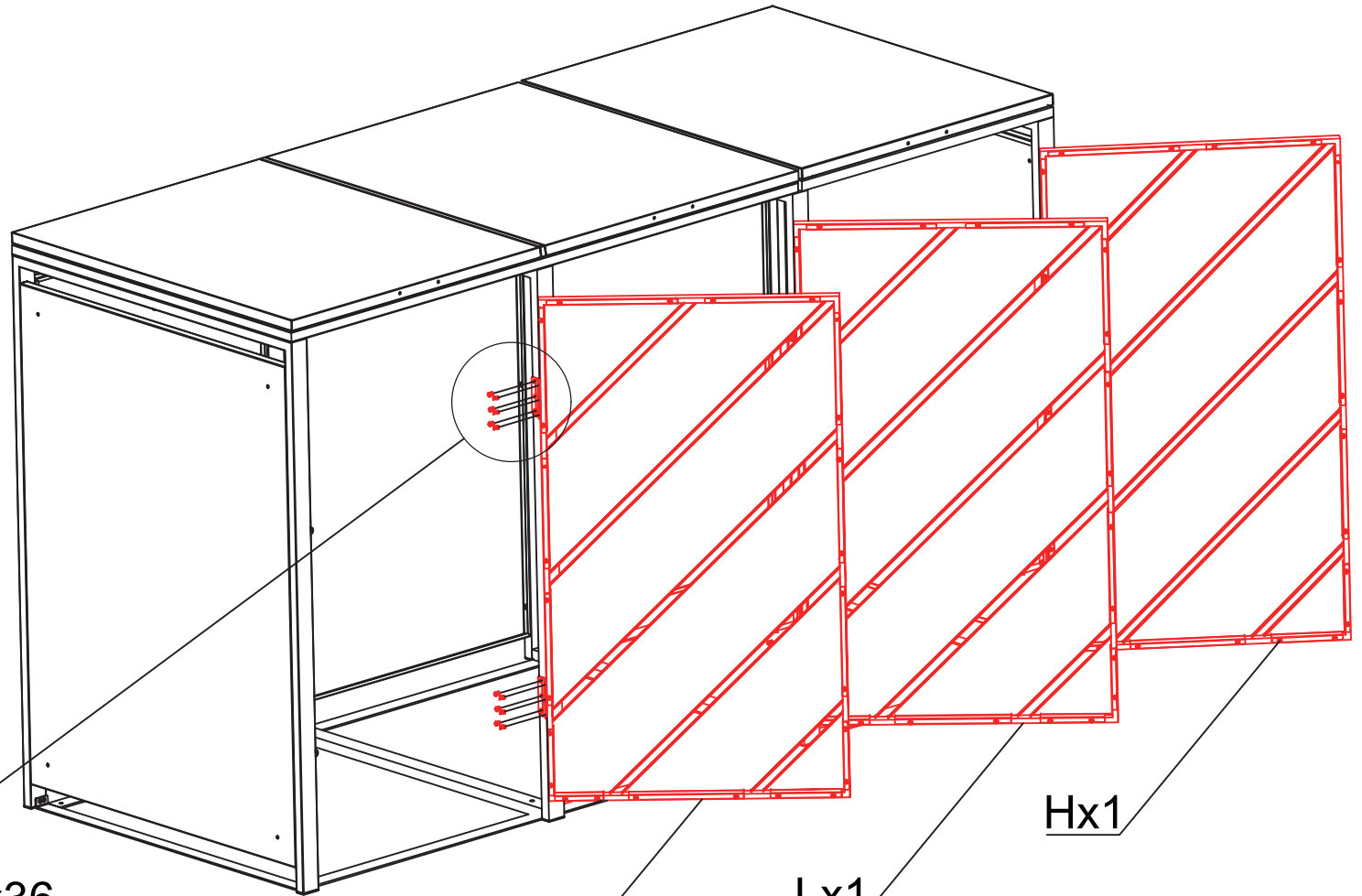
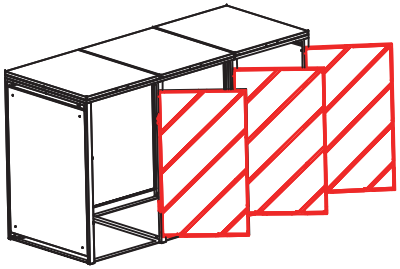

Kx6

Ux36

Hx1

Lx1

Hx1

# STEP 7

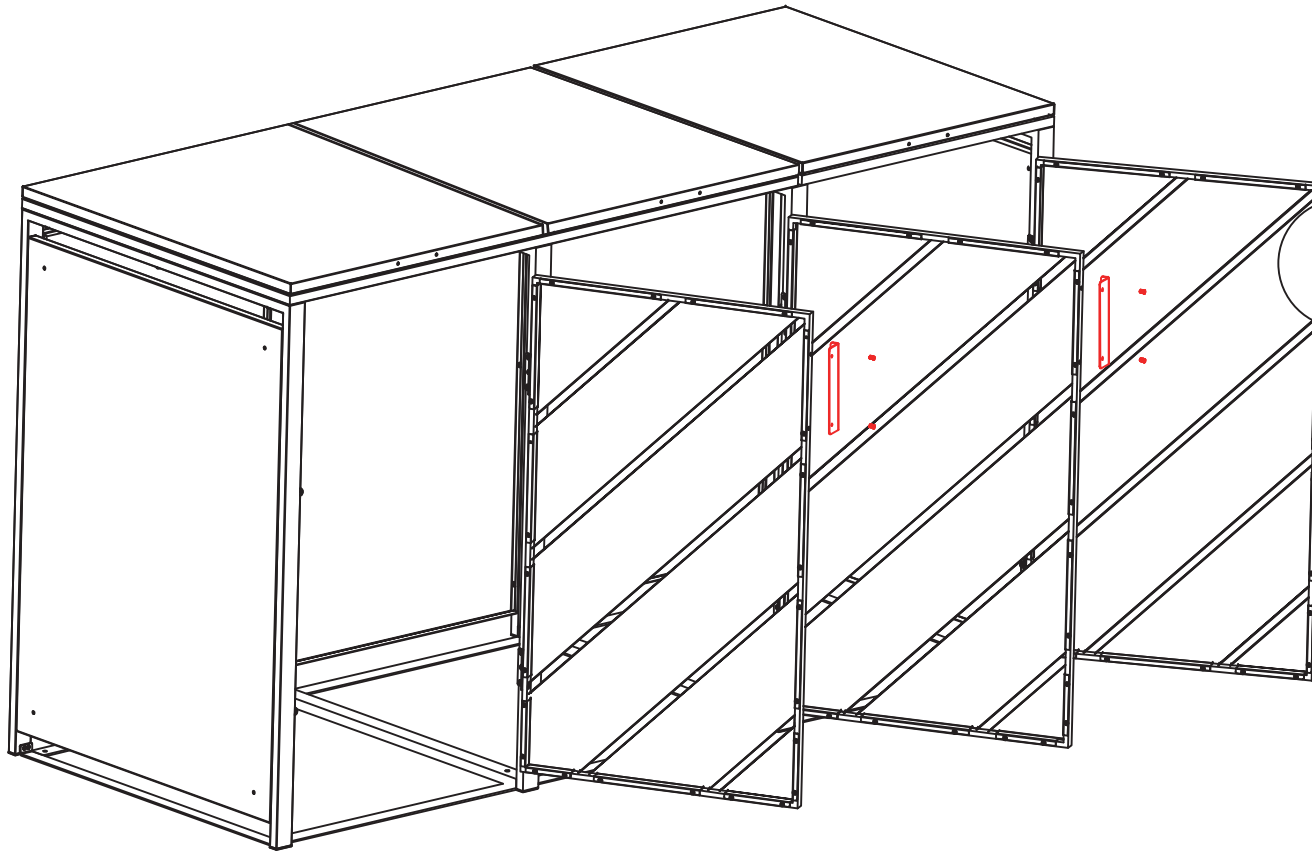
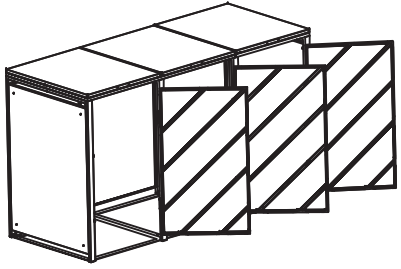

Mx3

Rx6

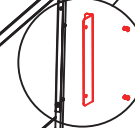
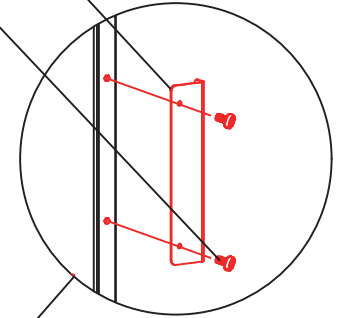

# STEP8

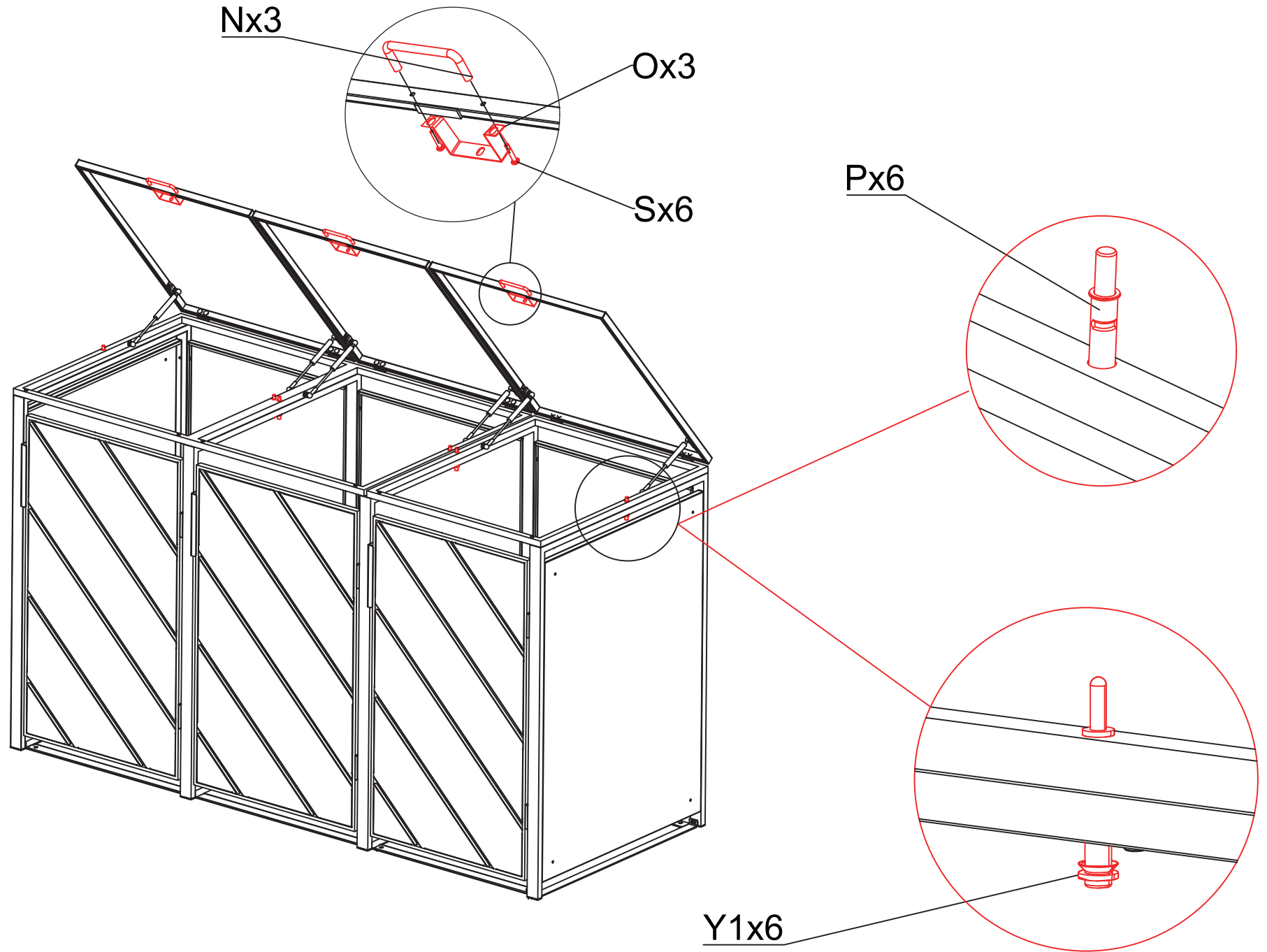

# STEP9

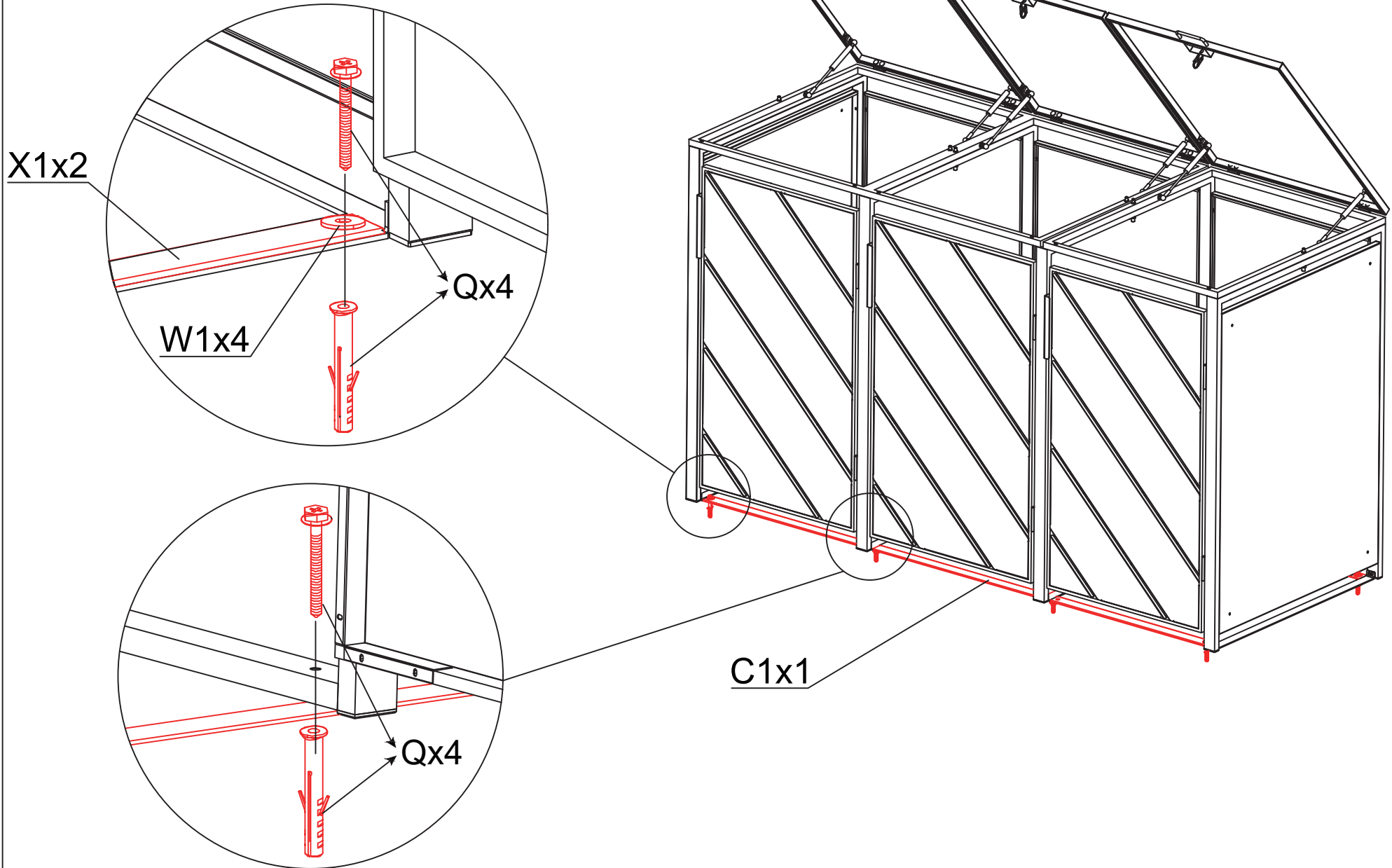

# STEP10

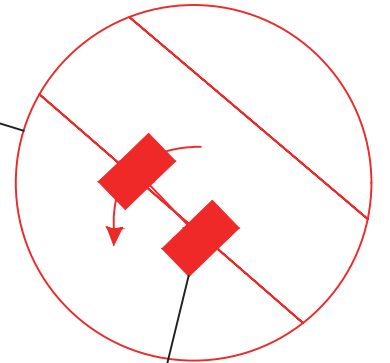
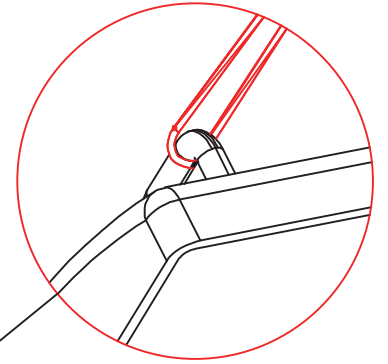
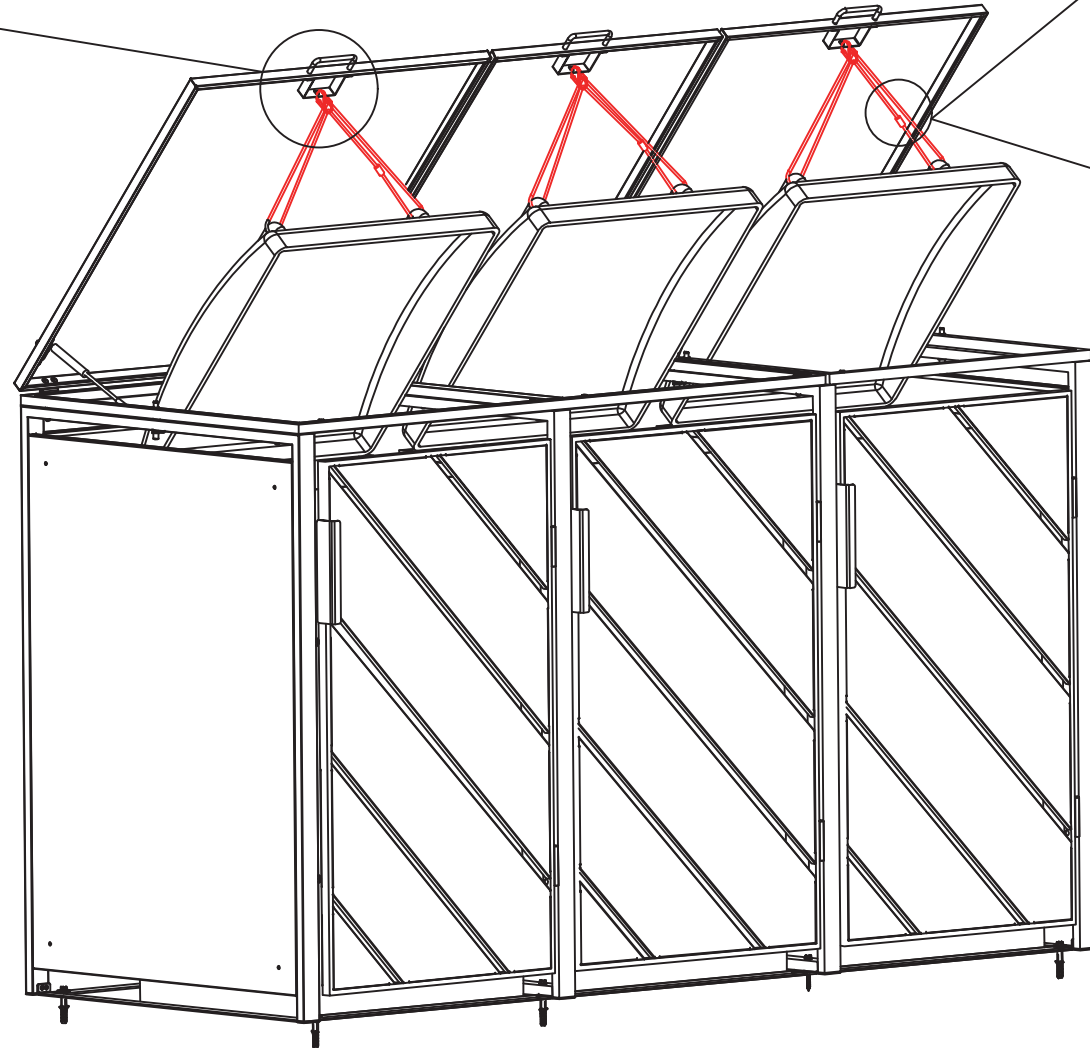
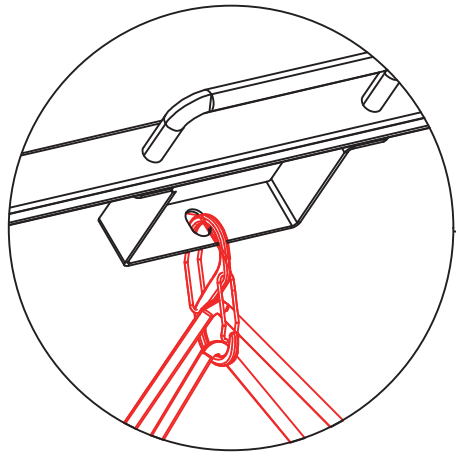

Vx3