

FAR TOOLS®



VB 1200

Professional Machine

FR	Aiguille vibrante à béton (Notice originale)
EN	Concrete vibrating needle (Original manual translation)
DE	Vibrationsnadel aus Beton (Übersetzung aus dem Original-Anleitung)
ES	Aguja vibratoria de hormigón (Traducción del manual de instrucciones originale)
IT	Ago vibrante per calcestruzzo (Traduzione dell'avvertenza originale)
PT	Agulha de vibração de concreto (Tradução do livro de instruções original)
NL	Beton trillende naald (Vertaling van de originele instructies)
EL	ΤΣΙΜΕΝΤΕΝΙΑ ΒΕΛΟΝΑ ΔΟΝΗΣΗΣ (ΑΡΧΙΚΕΣ ΟΔΗΓΙΕΣ)
PL	Igła wibracyjna do betonu (Tłumaczenie z oryginalnej instrukcji)
FI	Betoni tärisevä neula (Käännös alkuperäisestä ohjeet)
SV	Betongvibrerande nål (Översättning från originalinstruktioner)
BU	Бетонна вибрираща игла (Превод на оригиналната инструкция)
DA	Beton vibrerende nål (Oversættelse fra oprindelige brugsanvisning)
RO	Acuș vibrator din beton (Traducere din instrucțiunile originale)
RU	Вибрирующая игла для бетона (Перевод с оригинальной инструкции)
TU	Beton titreşimli iğne (Orijinal talimatlar çeviri)
CS	Betonová vibrační jehla (Překlad z originálního návodu)
SK	Betónová vibračná ihla (Preklad z originálneho návodu)
HE	מחט רטט בטון (הוראות מקוריית)
AR	إبرة اهتزاز الخرسانة (التعليمات الأصلية)
HU	Beton rezgő tű (Fordítás az eredeti utasítások)
SL	Betonska vibrirajoča igla (Prevod iz izvirnih navodil)
ET	Betoonist vibreeriv nõel (Tõlge originaal juhiseid)
LV	Betona vibrējoša adata (Tulkojumā no instrukcijas oriģinālvalodā)
LT	Betoninė vibruojanti adata (Vertimas iš originalių instrukcijas)
HR	Betonska vibrirajuća igla (Prijevod prema originalne upute)





10 min

Description et repérage des organes de la machine
Description and location of machine parts

A

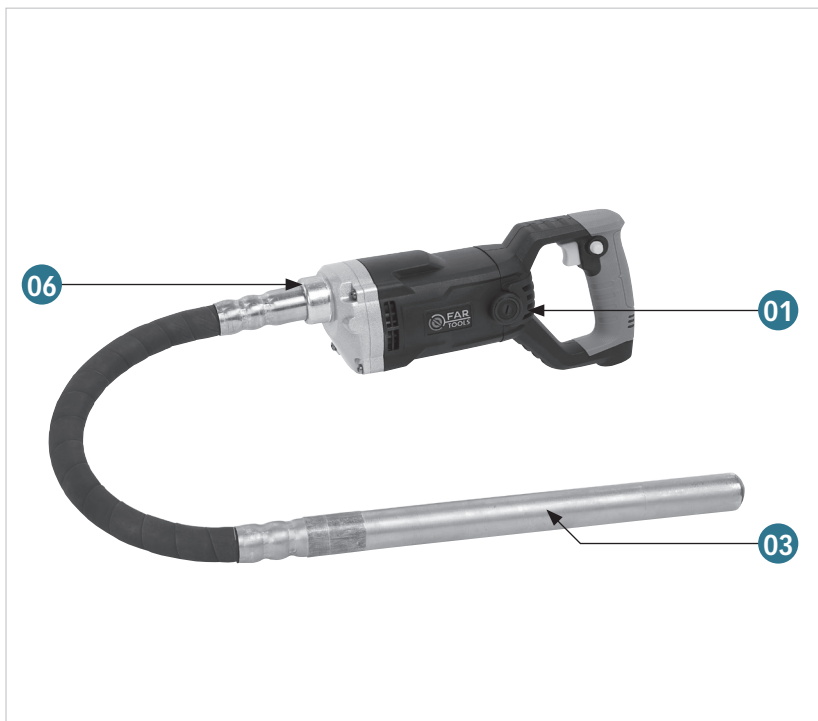

Contenu du carton
Contents of box

C



D

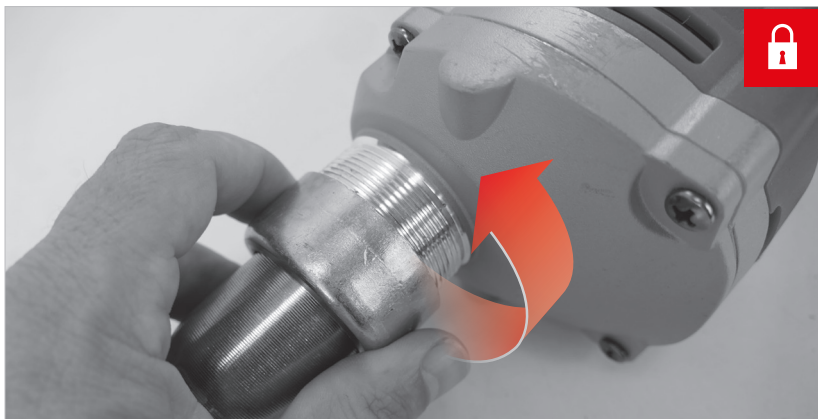
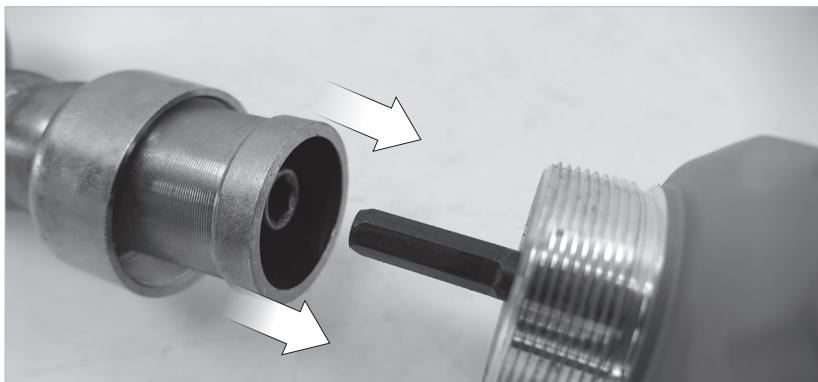
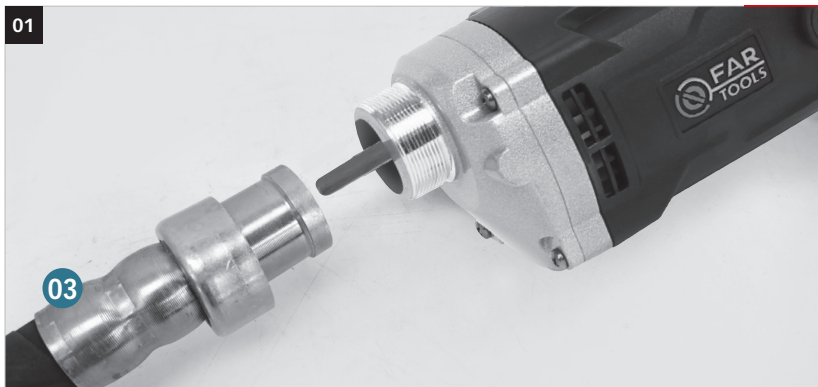

E

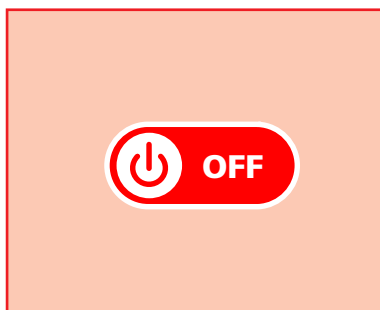
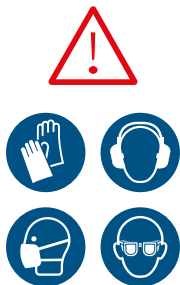
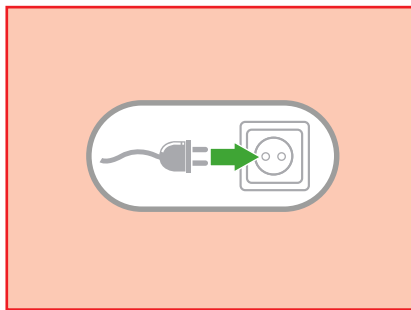

E

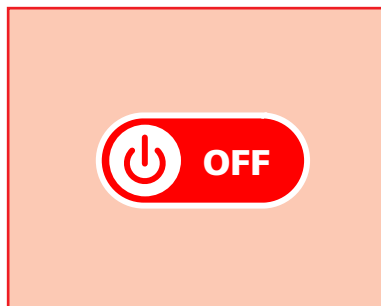
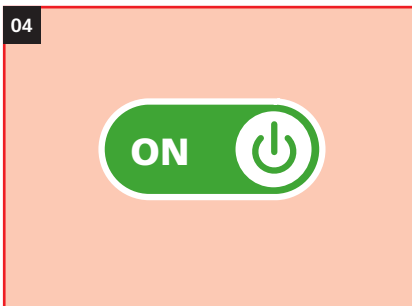

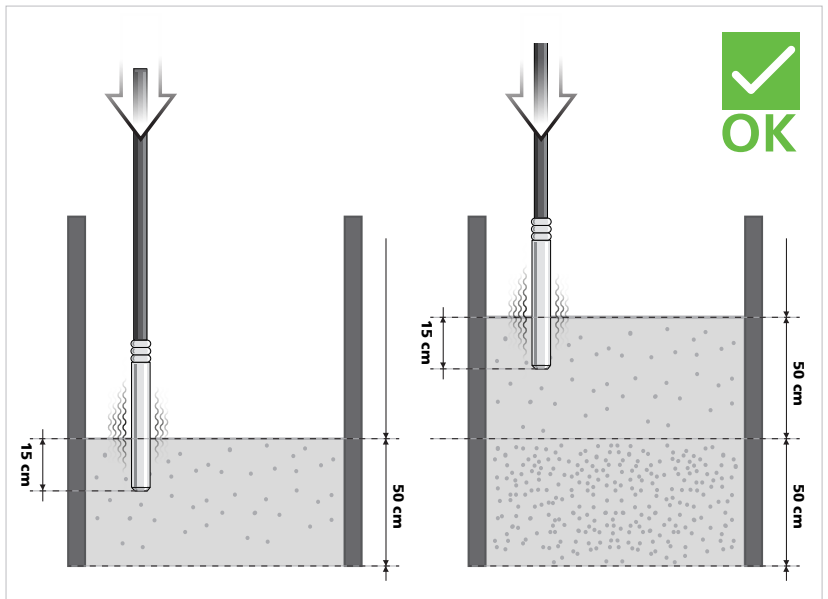
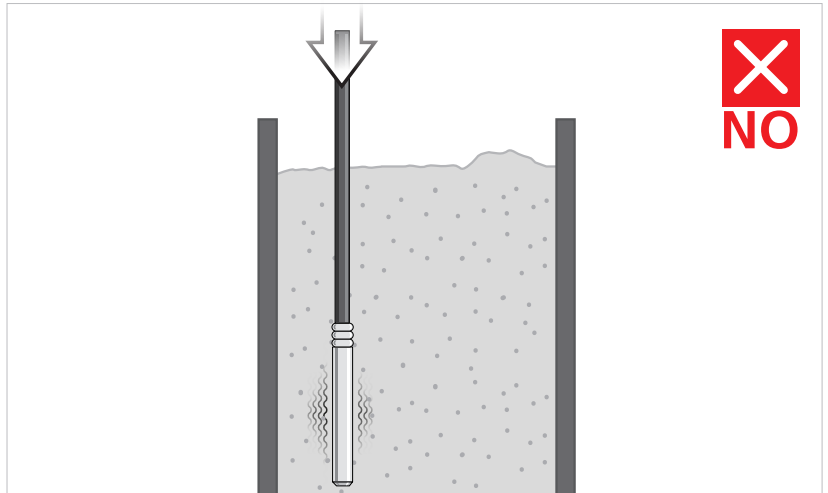
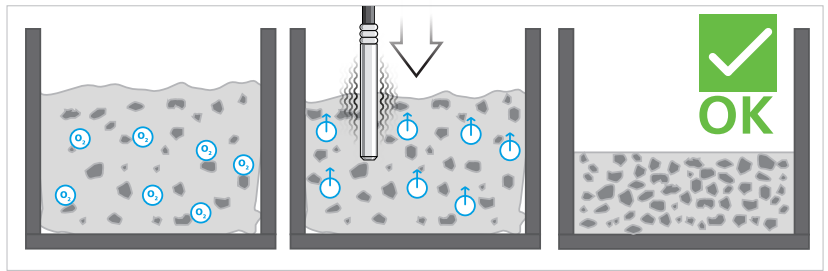
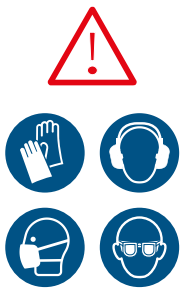

G

01

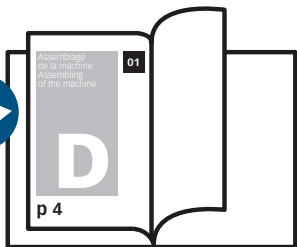

Option - Option - Option - Opcional - Opzione - Opção - Opție - Опціон - Опція -
Valinnainen - Tillval - Дополнително - Ekstra údstyr - Opzione - Оптация -
Seçenek / seçim - Volba - Volba - رایج - Opció - Možnosť - Valik - Opција - Izvēle

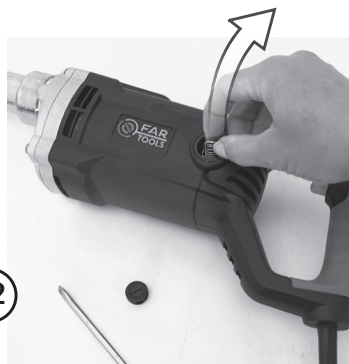
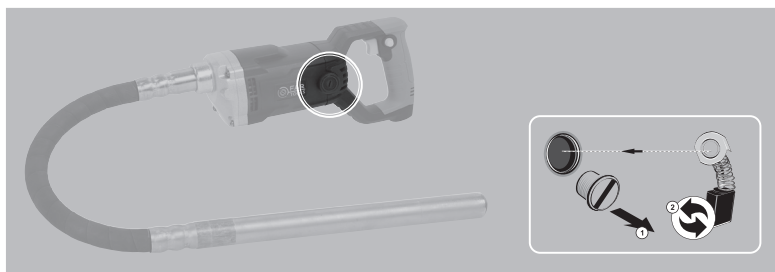

H

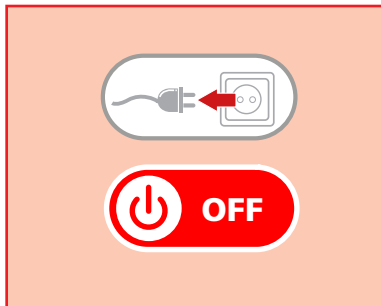

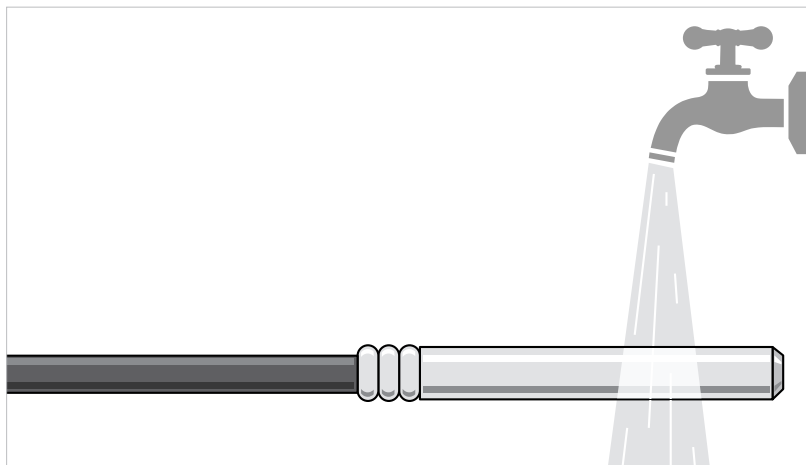
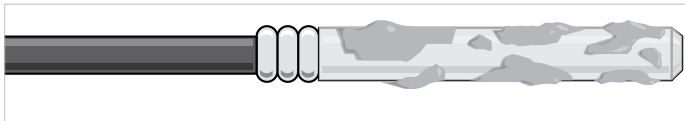

X
NO



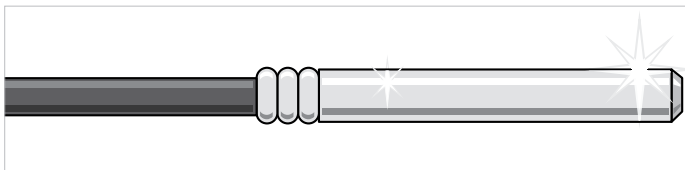

✓
OK





	<p>Tension et fréquence assignée: Nominal frequency and power: Spannung und Frequenz: Tensión y frecuencia fijada: Tensione e frequenza assegnata: Tensão e frequência fixa: Aangewezen spanning en frequentie: ΟΝΟΜΑΣΤΙΚΗ ΤΕΑΣΗ ΚΑΙ ΣΥΧΝΟΤΗΤΑ: Napięcie i częstotliwość przydzielona: Jännite ja määrittäty taajuus: Angiven spänning och frekvens: Anført spænding og frekvens: Tensiune și frecvență de lucru:</p>	<p>Заданное напряжение и частота: Tahsis gerilimi ve frekans: Stanovené napětí a frekvence: Stanovené napätie a frekvencia: מתח ומדר מקוצב. الفصلطية والذبذبة المبرمجة. Névfleges feszültség és frekvencia: Napetost in določena frekvenca: Консумирано напрежение и честота: Määratud pinge ja sagedus Nustatyta įtampa ir dažnis Noteiktais spriegums un frekvence. Napon i nazivna frekvencija:</p>	<p>230 V ~ 50 HZ</p>
---	---	--	----------------------

	<p>Puissance assignée: Nominal power: Leerlaufdrehzahl: Potencia fijada: Potenza assegnata: Potência assinada: Onbelast toerental: ΟΝΟΜΑΣΤΙΚΗ ΙΣΧΥΣ : Prędkość na biegu jałowym: Teho: Angiven effekt: Anført styrke: Putere de lucru:</p>	<p>Заданная мощность: Tahsis edilen güç: Stanovený příkon: Predpísaný výkon: כוח מקוצב. القدرة المبرمجة. Névfleges teljesítmény : Določena jakost: Консумирана мощность: Määratud võimsus. Nustatyta galia Noteiktā jauda Nazivna snaga:</p>	<p>1100 W</p>
--	--	--	---------------

	<p>Classe d'isolement : 2 Insulation class : 2 Isolierung Klasse : 2 Aislamiento clase :2 Isolamento classe :2 Isolamento classe :2 Isolatie Klasse : 2 ΕΡΓΑΛΕΙΟ ΤΕΑΙΗΖ : 2 Izolacja Klazy :2 Eristysluokka :2 Isolering Klass :2 Isoleringsklasse 2 Clasă izolație :2</p>	<p>Класс изоляции 2 : Yalitim derecesi :2 Třída izolace :2 Izolačný systém 2 סוג בידוד 2. فئة العزل 2. Szigetelési osztály :2 Razred izolacije :2 Инструмент Клас :2 Isolatsiooniklass 2 Izoliācijas rūšis 2 Izolācijas klase 2 Izolacija klasa: 2</p>	<p>X</p>
---	--	--	----------

	<p>Vitesse à vide: No-load speed: Drehzahl unbelastet: Velocidad vacía: Velocità a vuoto: Velocidade no vácuo: Leerlaufdrehzahl: ΤΑΧΕΥΤΗΤΑ ΣΤΟ ΚΕΝΟ: Prędkość bez bciążenia: Tyhjäkäyntinopeus Tomgångshastighet: Hastighed i ubelastet tilstand: Viteza în gol:</p>	<p>Скорость вращения на холостом ходу: Boşalma hızı: Rychlost naprázdno: Rýchlosť pri chode naprázdno: מהירות ריק. السرعَة على الفارغ. Üres sebesség: Prosti tek: Скорост на празни обороти: Kiirus tühikäigul Tušchio prietaiso greitis Tukšgaitas ātrums Brzina praznog hoda:</p>	<p>4400 min⁻¹</p>
---	--	---	------------------------------

	Porter des lunettes de sécurité : Wear protective eyewear : Schutzbrille tragen : Llevar puestas gafas protectoras : Portare de gli occhiali di sicurezza : Utilizar óculos de segurança : Draag een veiligheidsbril : ΦΟΡΑΤΕ ΠΡΟΣΤΑΤΕΥΤΙΚΑ ΓΥΑΛΙΑ: Zakładać okulary ochronne : Käytät suojalaseja : Använd skyddsglasögon : Der skal benyttes sikkerhedsbriller : Purtati ochelari de protectie :	Наденьте защитные очки : Güvenlik gözlükleri takın : Používejte bezpečnostní brýle : Noste ochranné okuliare : Bruk vernebriller: حامل نظارات وقائية. Viseljen védőszemüveget : Nositi zaščitna očala : Да се използват защитни очила : Kandke kaitseprille Nešioti apsauginius akinius Valkät aizsargbrilles Nositi zaštitne naočale:	×
--	--	--	---

	Porter un masque anti-poussière : Wear a dust mask : Staubschutzmaske tragen : Llevar puesta una careta de protección contra el polvo : Indossare una mascherina anti-polvere : Utilizar uma máscara anti-poeira : Draag een stofmasker : ΦΟΡΕΣΤΕ ΜΑΣΚΑ ΓΙΑ ΤΗ ΣΚΟΝΗ: Zakładać maskę przeciwpylową Käytät pölysuojust : Bär mask mot damm : Der skal benyttes beskyttelsesmaske mod støv: Purtati mască anti-praf :	Наденьте респиратор : Toza karşı maske takın : Používejte masku proti prachu : Noste ochrannú masku proti prachu : Bruk en støvmaske: لبس قناع مضاد للغبار. Viseljen porvédő maszkot Nositi zaščitno masko proti prahu: Да се използва защитна маска : Kandke tolumumaski. Dévėti respiratorių Valkät aizsarg masku pret putekļiem Nositi masku za zaštitu od prašine:	×
--	---	--	---

	Porter une protection auditive : Wear hearing protective equipment: Gehörschutz tragen: Llevar puesta una protección auditiva: Portare una protezione uditiva: Utilizar uma protecção auditiva: Draag gehoorbeschermers: ΦΟΡΑΤΕ ΠΡΟΣΤΑΣΙΑ ΑΚΟΗΣ: Zakładać słuchawki ochronne Käytät kuulosuojaimia: Bär hörselskydd: Der skal benyttes høreværn: Purtati căști de protectie auz:	наденьте средства звуковой защиты: İşitsel koruma aleti takın: Používejte ochranu sluchu: Noste ochranné slúchadlá: Bruk hørselsvern: لبس خوذة خضض الضرجي Viseljen fülvédőt Nositi zašito ušes: Да се използва слухови защитни средства: Kandke kõrvakaitset Nešioti apsaugą nuo triukšmo Valkät dzirdes aizsarglīdzekli Nositi štītnike protiv buke:	×
--	--	---	---

	Porter des gants : Use rubber gloves : Schutzhandschuhe tragen : Llevar guantes de protección : Indossare i guanti di protezione : Utilizar luvas de protecção : Draag veiligheidshandschoenen : ΦΟΡΩΝΤΑΣ ΓΑΝΤΙΑ: Używać rękawic ochronnych : Käytät suojakäsineitä : Använd skyddshandskar : Der skal benyttes handsker : Purtati mănuși :	Наденьте перчатки : Eldiven takın : Noste rukavice : Noste rukavice : Bruk hansker: لبس قفازات. Viseljen kesztyű t Nositi rokavice: a se използват предпазни ръкавици : Kandke kindaid Müvēti pirštines Valkät cimdus Nositi zaštitne rukavice:	×
--	---	---	---

	<p>Lire les instructions avant usage : Read the instructions before use : Vor Einsatz des Geräts Anweisung lesen : Léase las instrucciones antes de usar : Leggere le istruzioni prima dell'uso : Ler as instruções antes da utilização : Lees voor het gebruik de instructies : ΔΙΑΒΑΣΤΕ ΤΙΣ ΟΔΗΓΙΕΣ ΠΡΙΝ ΑΠΟ ΤΗ ΧΡΗΣΗ: Zapoznać się instrukcją przed użyciem : Lue ohjeet ennen käyttöä : Läs anvisningarna före användning : læs instruktionerne før brug Înainte de utilizare, cititi instructiunile :</p>	<p>Внимательно прочитайте следующие инструкции : Kullanmadan talimatları okuyunuz : Pozorně si přečtěte následující pokyny : Pred použitím si prečítajte pokyny : Les bruksanvisningen før bruk: اقرأ التعليلات قبل الالستخدام. használat elott olvassuk el az utasítást : Pred uporabo preberite ustrezna navodila Прочетете указанията за употреба : Enne kasutamist lugege instruksiooni Prieš naudojimą perskaityti instrukciją izlasīt instrukcijas pirms lietošanas Pročitati upute prije uporabe:</p>	<p>X</p>
---	--	--	----------

	<p>Conformité européenne Conforms to EC standards : CE-Konformität : Cumple con las directivas CE : Conforme alle norme CE : Conforme às normas CE : Voldoet aan de EG-normen : ΕΥΡΩΠΑΪΚΗ ΣΥΜΜΟΡΦΩΣΗ Zgodność z normami CE : EU-standardien mukainen : EU-standardien mukainen : Overholder EU standarderne : Conform cu normele europene:</p>	<p>соответствие европейским стандартам: Avrupa uygunluk : evropská shoda : európska dohoda : Europeisk konformitet قطابق للجواصفات الأوروبية. evropska ustreznost : európai megfeleléség : Съответствие с европейските норми : Euroopa Liidu vastavusmärk Europinių normų atitikima Atbilstība Eiropas standartiem Evropska sukladnost</p>	<p>X</p>
--	--	--	----------

	<p>Danger : Danger : Gefahr : Peligro : Pericolo : Perigo : Gevaar : ΚΙΝΔΥΝΟΣ: Niebezpieczeństwo : Vaara : Fara : Fare : Pericol :</p>	<p>Опасно : Tehlike : Nebezpečí : Nebezpečnosto : Fare: خطر. Veszély : Nevarnost: Опасност : Oht Pavojus Bīstamība Opasnost:</p>	<p>X</p>
--	--	--	----------

	<p>Poids : Weight : Gewicht : Peso : Peso : Peso : Gewicht : ΒΑΡΟΣ : Masa : Paino : Vikt : Vægt : Greutate :</p>	<p>Bec : Ağrlık : Hmotnost : Hmotnosť : Vekt: الوزن. Súly : Teža : Терло : Raskus Svoris Svars Težina</p>	<p>5,6 kg</p>
---	--	---	---------------

 L_{pA}	Niveau de pression acoustique : Acoustic pressure level : Schalldruckpegel : Nível de presión acústica : Livello di pressione acustica : Nível de pressão acústica : Niveau akoestische druk : ΣΤΑΘΜΗ ΗΧΗΤΙΚΗΣ ΠΙΕΣΗΣ: Poziom mocy akustycznej : Käytä kuulosuojaimia: Ljudtrycksnivå : Lydtryk : Nível presiune acustică :	Уровень акустического давления : Akustik basınç seviyesi : Hladina akustického tlaku : Hladina akustického tlaku : Lydtrykknivå: مستوى الضغط الصوتي. A hangnyomás szintje : Nivo akustičnega pritiska: Равнище на акустично налягане : Helirõhu tase Akustinio spaudimo lygis Akustiskā spiediena līmenis Razina zvučnog tlaka:	79,8 dB (A)

 L_{WA}	Niveau de puissance acoustique : Acoustic power level : Schalleistungspegel : Nível de potencia acústica : Livello di potenza acustica: Nível de potência acústica: Niveau akoestisch vermogen : ΕΠΙΠΕΔΟ ΙΣΧΥΟΣ ΗΧΟΥ: Poziom mocy akustycznej : Käytä suojalaseja : Ljudstyrkenivå : Lydstyrke : Nível putere acustică :	уровень мощности звука : Akustik basınç seviyesi : Hladina zvukového výkonu: Hladina zvukového výkonu: Lydeffektivitá: مستوى الخرجي. a hangnyomás szintje : Nivo akustične jakosti : Равнище на вибрации : Helivõimsuse tase Triukšmo lygis Akustiskās jaudas līmenis Razina zvučnog snage:	90,8 dB (A)

NEAU SONORE D'ÉMISSION : A VIDE

Pression acoustique LpA poste opérateur 79,8 dB
Incertitude 3

Puissance acoustique LWA 90,8 dB
Incertitude 3

Valeurs déterminées suivant le code d'essai de l'annexe B de la norme EN 61029-1 avec emploi des normes de base ISO 11201 et ISO 3744.

Les niveaux de pression acoustique obtenus in situ dépendent:

- Des niveaux réels de la machine considérées, en prenant en compte les incertitudes déclarées;
- Du local et de l'installation de la machine. Préférez une pièce dont l'acoustique est plus feutrée. Evitez les pièces vides à grande résonance. Placez vous auprès d'une fenêtre le cas échéant.
- Des outils montés, des pièces travaillées, des réglages choisis,...

	Niveau de vibration : Hand/arm vibration level : Vibrationspegel Hand/Arm : Nível de vibración mano/brazo : Livello di vibrazione mano/braccio : Nível de vibração mão/braço : Trillingsniveau hand/arm : ΕΠΙΠΕΔΟ ΚΡΑΔΑΣΜΩΝ: Poziom wibracji rżka/ramię : Tärinätaso: Vibrationsnivå hand/arm : Vibrationsniveau : Nível vibrații :	Уровень вибрации : Titreşim seviyesi : Úroveň vibrací : Hladina vibrácií : Vibrasjonsnivå: مستوى الارتجاج. Vibrációsztint : Nivo vibracij : Равнище : Vibrācijas līmenis. Vibracijos lygis Vibratsiooni tase Razina vibracije:	11,945 m / s ²

VIBRATIONS:

Total des valeurs de vibration (somme vectorielle des trois directions) déterminée selon EN 60745 :

a 11,945 m/s²
Incertitude K 1,5 m/s²

L'amplitude d'oscillation peut être utilisée comme valeur de comparaison d'outils électroportatifs.

Attention : si l'outil électroportatif est utilisé pour d'autres applications, avec d'autres outils de travail, l'amplitude d'oscillation peut être différente.

	<p>Soumis à recyclage Subjected to recycling Sujeto a reciclaje Sottoposti a riciclaggio Sujeitos à reciclagem Não deite no lixo : Niet wegwerpen : ΥΠΟΚΕΙΤΑΙ ΣΕ ΑΝΑΚΥΚΛΩΣΗ Nie wyrzucac : Älä heitä pois luontoon : Batteriet får inte kastas : Bortkast det ikke: Nu le auncati :</p>	<p>Подлежит переработке Atmayiniz : Nevy hazujte je do bežného odpadu : Neodhadzovat : Gjenvinningspliktig فلا ترمدها هكذا في القمامة. ne mečíte1 Ne odvržite ga/jih vstran : Taaskasutusse kuuluv Ärge visake seda minema : Nemetykíte : Nemest : Podvrgnuto recikliranju</p>	×
--	---	--	---

Recyclage des déchets :

Les outils, accessoires et leur emballages doivent suivre une voie de recyclage adaptée. Conformément aux directives Européenne 2012/19/UE et 2006/66/CE, les composants d'un produit doivent être séparés, collectés, recyclés ou éliminés en conformité avec les réglementations environnementales en vigueur. Les appareils, batteries, piles, huiles, emballages devront être déposés dans les systèmes d'élimination des déchets spéciaux tels que déchetteries. Renseignez-vous auprès de votre commune pour connaître l'organisme le plus proche à même de retraiter ou de collecter ces déchets.

	<p>Recyclable, soumis au tri sélectif Recyclable, subject to recycling Recyclingfähige, unterliegen Recycling Reciclables, sujetos a reciclaje Riciclabili, soggetti a riciclaggio Recicláveis, sujeito à reciclagem Recycleerbare, onderworpen aan recycling ΑΝΑΚΥΚΛΩΣΙΜΟ, ΥΠΟΚΕΙΤΑΙ ΣΕ ΕΠΙΛΕΚΤΙΚΗ ΔΙΑΛΟΓΗ Opakowanie nadaje się do recyklingu podlegają recyklingu Kierrätettävien pakkausten kohteena kierrätys Återvinningsbara förpackningar omfattas återvinning Рециклираци се опаковки подлежат на рециклиране Genanvendelig underlagt genbrug</p>	<p>Reciclabile sub rezerva reciclare Повторно упаковка подлежит вторичной переработке Geri dönüřüm Geri dönüřtürülebilir ambalaj konusu Recyklovateľné podľehajúci recyklácii Recyklovateľné podliehajúce recyklácii Resirkulerbar, med förbehold om selektiv sortering ريودنلا فدا عال عيřخت ريودنلا فدا عال تلباؤلا فيلغئلا و تخب عئلا Újrahasznosítható csomagolás alá újrahasznosítás Reciklirati predmet recikliranja Pakendite suhtes ringlussevõtu Pārstrādājams iepakojumš otrreizējai pārstrādei Perdirbamų taikomos perdirbimo Može se reciklirati, podložno selektivnom sortiranju</p>	×
--	--	---	---

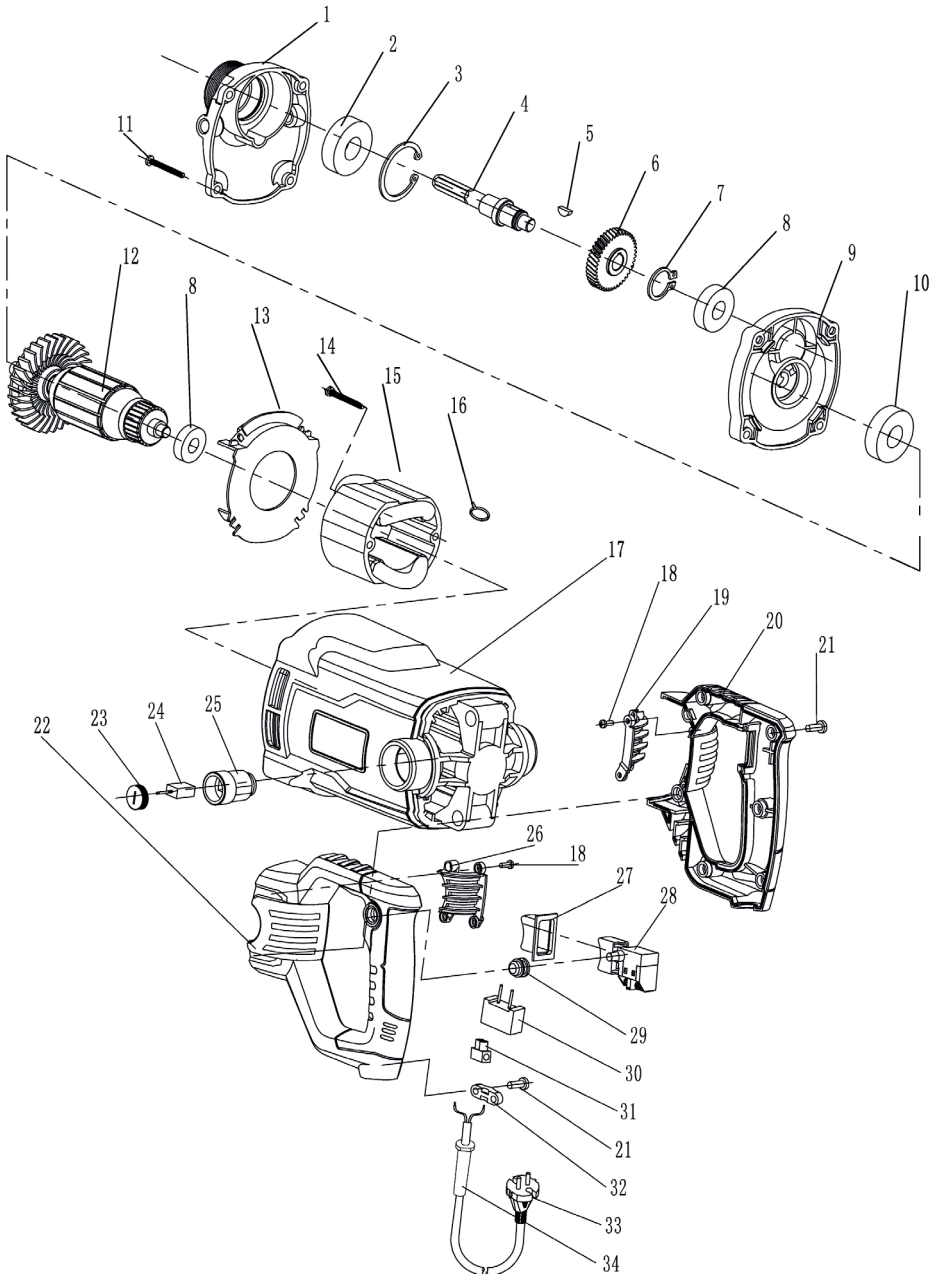

DECLARATION DE CONFORMITE
 VERKLARING VAN OVEREENSTEMMING
 DECLARACION DE CONFORMIDAD
 DICHIARAZIONE DI CONFORMITA
 KONFORMITÄSERKLÄRUNG
 DECLARATION CONFORMITY
 DECLARAÇÃO DE CONFORMIDADE
 DEKLARACJA ZGODNOSCI Z NORMAMI
 OMI ÖVERENSSTÄMMELSE
 VAATIMUSTENMUKAISUUSVAKUUTUS
 OVERENSSTEMMELSESERKLÆRING
 ΔΗΛΩΣΗ ΣΥΜΜΟΡΦΩΣΗΣ

DECLARATIE DE CONFORMITATE
 VYHLÁSENIE ZHODY
 Декларация соответствия
SAMSVARSERKLÆRING
 Uygunluk beyanı
 التصديق بالمطابق ة
PROHLÁSENIE SHODY
EGYZEZŐSÉGI NYILATKOZAT
 Декларация за съответствие с нормите
IZJAVA O SUKLADNOSTI
 DEKLARACIJA
 ATITIKTIES DEKLARACIJA
 KINNITUS
IZJAVA O SUKLADNOSTI

Le soussigné,
 Ondergetekende,
 Der Unterzeichner,
 O abaxo assinado,
 Undertecknad,
 Dolupodpisaniyat
 Undertegnede
 Subsemnatul,
 Я, нижеподписавшийся,
 Imzalayan,
 Nize podepsany,
 Toliau pasirašęs

Personne autorisée à constituer
 le dossier technique :
 Christophe HUREL



FAR GROUP EUROPE
 192, Avenue Yves Farge
 37700 St. Pierre-des-Corps
 FRANCE

El suscrito,
 Il sottoscritto,
 The undersigned,
 Níneí podpísany
 Allekirjoittanut,
 Ο ΚΑΤΩΘΙ ΥΠΟΓΡΑΦΜΕΝΟΣ,
 Nizšie podpísany
 Undertegnede,
 الحقوقي اندازاه
 Alulírótt,
 Podpisani,
 Apakšá parakstijies
 allakirjutanu
 Dolje potpisani,

Declara por la presente, que,
 Dichiare che,
 Declares that,
 OOwiadcza niniejszym, że
 Ilmoittaan täten että,
 ΔΙΑ ΤΟΥ ΠΑΡΟΝΤΟΣ ΔΗΛΩΝΕΙ 'ΟΤΙ,
 tūmto vyhláshuje, že
 Erklærer herved at,
 я, нижеподписавшийся, что
 kijelentem, hogy a készülék izjavlja da,
 Pareiskia, kad,
 Ar šo apliecina, ka,
 Kinnitab, et
 izjavljuje u ovom dokumentu da je

Aiguille vibrante à béton / Concrete vibrating needle / Vibrationsnadel aus Beton / Aguja vibratoria de hormigón / Ago vibrante per calcestruzzo /
 Agulha de vibração de concreto / Beton trillende naald / ΤΣΙΜΕΝΤΕΝΙΑ ΒΕΛΟΝΑ ΔΟΝΗΣΗΣ / Iгла vibracjona do betonu / Betoni tärisevä neula /
 Betongvibrerande nål / Бетонна вибрираща игла / Beton vibrerende nål / Acul vibrator din beton / Вибрирующая игла для бетона / Beton titresimil iğne /
 Betonová vibrační jehla / Betonová vibrační ihla / شويجرام زتحت قريبا / Beton rezgő tű / Betonska vibrirajuća igla / Beetoonist vibreeriv noel /
 Betona vibrējoša adata / Betoninė vibruojanti adata / Betonska vibrirajuća igla

code

FARTOOLS / 116560 / VB 1200 / 3235

Est conforme et satisfait aux directives et normes CE,
 In overeenstemming is met en voldoet aan EG richtlijnen,
 Den folgenden EU-Bestimmungen entspricht,
 Respeita e está em conformidade com as normas CE,
 Överensstämmer med och uppfyller EG-standarder,
 Съответства и отговаря европейските норми
 Er i overensstemmelse med og overholder EU standarderne
 Este conform și satisface normele CE
 полностью соответствует и удовлетворяет
 требованиям стандартов ЕС
 CE sartlara uygundur,
 odpovídá normám ES.
 Atitinka ir atitinka EB direktyvas ir standartus,

Cumple con la directivas de la CE,
 E conforme alle direttive CEE,
 Complies with the EEC directives and standards,
 Odpowiada normom UE,
 Täyttää EU-vaatimukset,
 ΣΥΜΜΟΡΦΩΝΕΤΑΙ ΚΑΙ ΙΚΑΝΟΠΟΙΕΙ ΤΙΣ ΟΔΗΓΙΕΣ ΚΑΙ ΤΑ ΠΡΟΤΥΠΑ CE,
 zodpovedá normám ES,
 Samsvarer med og tilfredsstiller CE-direktiver og standarder,
 Бан алжаз и مطابق و یایی مءای یور مجوعه الدول الودوبیة
 kielgitti a CE szabványok előírásait.
 Je v skladu z in izpolnjuje norme Evropske skupnosti.
 Atbilst en atbilst EK direktivas un standartus,
 Vastab ja vastab EU direktiividele ja standarditele,
 Sukladan i ispunjava direktive i standarde CE,

2014/30/EU MD :2006/42/EC 2011/65/
 EU 2015/863/EU

EN 60745-1:2009+A11:2010 EN
 60745-2-12:2009
 EN IEC 55014-1:2021
 EN IEC 55014-2:2021
 EN IEC 61000-3-2:2019+A1:2021 EN
 61000-3-3:2013+A1:2019+A2:2021

Christophe HUREL,
 Président Directeur Général
 26/10/2024
 Fait à St. Pierre-des-Corps

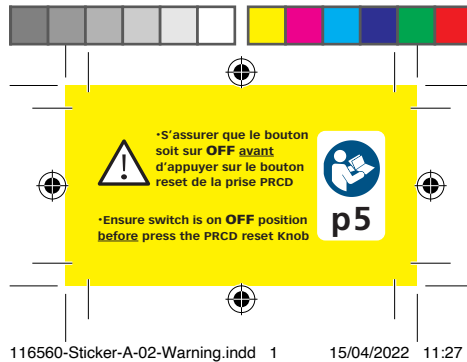
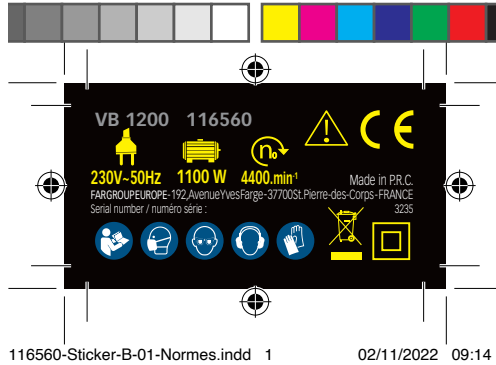



FR. GARANTIE

Cet outil est garanti contractuellement contre tout vice de construction et de matière, à compter de la date de vente à l'utilisateur et sur simple présentation du ticket de caisse. La garantie consiste à remplacer les parties défectueuses. Cette garantie n'est pas applicable en cas d'exploitation non conforme aux normes de l'appareil, ni en cas de dommages causés par des interventions non autorisées ou par négligence de la part de l'acheteur. La garantie ne s'applique pas sur les dommages causés par une défaillance de l'outil.

DE. GARANTIE

Die Garantiezeit für dieses Gerät in bezug auf Konstruktions- und Materialfehler beträgt lt. Vertrag bei Vorlage des Kassensbons. Die Garantieleistung besteht im Ersatz schadhafter Teile. Die Garantie erlischt bei einem Einsatz des Geräts, der nicht normentsprechend ist, bei Schäden, die auf unsachgemäße Eingriffe zurückzuführen sind bzw. bei Nachlässigkeit seitens des Käufers. Die Garantie erstreckt sich nicht auf Schäden, die auf Fehlfunktionen des Geräts zurückzuführen sind.

IT. GARANZIA

Quest' attrezzo è garantito per contratto contro qualsiasi difetto di costruzione e di materia, a partire dalla data di vendita all' utente e su semplice presentazione dello scontrino. La garanzia consiste nel sostituire le parti difettose. Questa garanzia non è applicabile in caso di sfruttamento non conforme alle norme dell' apparecchio, né in caso di danni causati da interventi non autorizzati o da negligenza da parte dell' acquirente. La garanzia non si applica ai danni causati da un' avaria dell' attrezzo.

EN. GARANTEE

This tool is guaranteed, in writing, against any defect in manufacture or parts from the date of sale, upon simple presentation of the sales slip. The guarantee is limited to the replacement of faulty parts. This guarantee is not applicable in the event of usage which is not conform with the intended usage of the apparatus, nor in the event of damage caused by unauthorised servicing or negligence on behalf of the purchaser. This guarantee does not apply to any damage caused by

the failure of this tool.

ES. GARANTIA

Esta herramienta se garantiza contractualmente contra todo defecto de construcción y materia, a partir de la fecha de venta a l' usuario y sobre simple presentación del recibo de caja. La garantía consiste en sustituir a las partes defectuosas. Esta garantía no es aplicable en caso de explotación no conforme a las normas del aparato, ni en caso de daños causados por intervenciones no autorizadas o por negligencia por parte del comprador. La garantía no se aplica sobre los daños causados por un fallo del herramienta.

NL. GARANTIE

Dit gereedschap heeft een garantie tegen constructiefouten en materiaaldefecten, die geldig is vanaf de aankoopdatum door de gebruiker, op vertoning van de kassabon. De garantie betreft de vervanging van de defecte onderdelen. Deze garantie is niet van toepassing indien het apparaat niet volgens de normen gebruikt is, noch in geval van schade veroorzaakt door onbeugelijk gebruik of nalatigheid van de koper. De garantie is niet van toepassing op schade voortvloeiend uit een defect van het gereedschap.

PT. GARANTIA

Esta ferramenta tem uma garantia contratual contra qualquer defeito de construção e de material, a partir da data de venda ao utilizador e sobre simples apresentação do talão da caixa. A garantia consiste em substituir as partes defeituosas. Esta garantia não é aplicável no caso de exploração não conforme as normas do aparelho, nem em caso de danos causados pelas intervenções não autorizadas ou por negligência da parte do comprador. A garantia não se aplica para os danos causados por uma falha da ferramenta.

EL. ΕΓΓΥΗΣΗ

ΑΥΤΟ ΤΟ ΕΡΓΑΛΕΙΟ ΕΙΝΑΙ ΣΥΜΒΑΤΙΚΑ ΕΓΓΥΗΜΕΝΟ ΓΙΑ ΟΠΟΙΟΔΗΠΟΤΕ ΚΑΤΑΣΚΕΥΑΣΤΙΚΟ ΚΑΙ ΥΛΙΚΟ ΕΛΑΤΤΩΜΑ, ΑΠΟ ΤΗΝ ΗΜΕΡΟΜΗΝΙΑ ΠΩΛΗΣΗΣ ΣΤΟΝ ΧΡΗΣΤΗ ΚΑΙ ΜΕ ΤΗΝ ΕΠΙΔΕΙΞΗ ΤΗΣ ΑΠΟΔΕΙΞΗΣ ΠΩΛΗΣΗΣ. Η ΕΓΓΥΗΣΗ ΣΥΝΙΣΤΑΤΑΙ ΣΤΗΝ ΑΝΤΙΚΑΤΑΣΤΑΣΗ ΤΩΝ ΕΛΑΤΤΩΜΑΤΙΚΩΝ ΕΞΑΡΤΗΜΑΤΩΝ. ΑΥΤΗ Η ΕΓΓΥΗΣΗ ΔΕΝ ΙΣΧΥΕΙ ΣΕ ΠΕΡΙΠΤΩΣΗ ΛΕΙΤΟΥΡΓΙΑΣ ΠΟΥ ΔΕΝ ΣΥΜΜΟΡΦΩΝΕΤΑΙ ΜΕ ΤΑ ΠΡΟΤΥΠΑ ΤΗΣ ΣΥΣΚΕΥΗΣ, ΟΥΤΕ ΣΕ ΠΕΡΙΠΤΩΣΗ ΖΗΜΙΑΣ ΠΟΥ ΠΡΟΚΑΛΕΙΤΑΙ ΑΠΟ ΜΗ ΕΥΘΥΣΙΟΔΟΤΗΜΕΝΕΣ ΕΠΕΜΒΑΣΕΙΣ Ή ΑΜΕΛΕΙΑ ΕΚ ΜΕΡΟΥΣ ΤΟΥ ΑΓΟΡΑΣΤΗ. Η ΕΓΓΥΗΣΗ ΔΕΝ ΙΣΧΥΕΙ ΓΙΑ ΖΗΜΙΕΣ ΠΟΥ ΠΡΟΚΑΛΟΥΝΤΑΙ ΑΠΟ ΑΣΤΟΧΙΑ ΕΡΓΑΛΕΙΟΥ.

PL. GWARANCJA

Narz dzie jest obj te gwaranc-

jà na wszelkie wady konstrukcyjne i materiałowe, licząc od daty sprzedaży u użytkownika i po okazaniu paragonu kasowego. Gwarancja obejmuje wymianę części wybrakowanych. Gwarancja nie znajduje zastosowania w przypadku u użytkownika niezgodnego z normami urządzenia, ani w przypadku szkód spowodowanych działaniami niedozwolonymi lub zaniedbaniami ze strony nabywcy. Gwarancja nie obejmuje szkód powstałych z powodu upadku urządzenia.

SV. GARANTI

Detta verktyg har en avtalsenlig garanti mot konstruktions och materialfel, från och med tidpunkten för användarens inköp och genom uppvisning av kassakvittot. Garantin består i att ersätta de bristfälliga delarna. Denna garanti gäller inte om användningen inte motsvarar apparatens standarder, inte heller vid skador som orsakas av ej tillåtna ingrepp eller på grund av köparens vårdslöshet. Garantin gäller inte forskador som orsakats av att verktyget fungerat bristfälligt.

FI. TAKU

Tämän laitteen takuu on voimassa sopimusmukaisesti kattaen kaikki rakennet- ja materiaali- ja lukien ostopaivästä kassakuittia vastaan. Takuu sisältää viallisten osien korvaamisen. Takuu ei korvaa ohjeidenvastaista käyttöä eikä valtuutettomattomien henkilöiden käsittelystä tai ostajan huolimattomuudesta aiheutuneita vahinkoja. Takuu ei vastaa myöskään toimintahäiriöistä aiheutuneita vahinkoja.

BU. Гаранция

Този инструмент е под договорна гаранция срещу всякакъв дефект в изработката и използваните материали, считано от датата на продажба на потребителя и само срещу представяне на касовата бележка. Гаранционното обслужване се състои в замяна на дефектните части. Настоящата гаранция не е валидна когато апаратът се използва по начин, несъответстващ на стандарта за работа с него, както и в случай на щети, нанесени от неоторизирани лица, или вследствие на провадена небрежност от страна потребителя. Гаранцията не покрива щети, произтекли вследствие на техническа неизправност на апарата.

DA. GARANTI

Dette værktøj er dækket af en garantikontrakt for konstruktions- og materialefejl, som gælder fra købsdatoen ved visning af kassebonen. Garantien består i at udskifte de defekte dele. Garantien dækker ikke fejl opstået som følge af anvendelse, som ikke overholder standarderne for apparatet, eller

SERVICE APRÈS VENTE - AFTER SALE SERVICE



skader opstået ved ikke autoriserede indgreb eller søsødet fra brugerens side. Garantien dækker ikke skader opstået, fordi værktøjet har svigtet.

RO. GARANTIE

Acest aparat este garantat din punct de vedere contractual împotriva tuturor viciilor de construcție și de material. Începând de la data vânzării lui către utilizator și la simpla prezentare a bonului de casă. Garanția constă în înlocuirea componentelor defecte. Această garanție nu se aplică în cazul exploatarei în alt mod decât cel recomandat de normele aparatului și nici în caz de stricăciuni provocate de intervenții neautorizate sau prin neglijența cumpărătorului. Garanția nu se aplică asupra pagbelor cauzate de o defectare a aparatului.

RU. ГАРАНТИЯ

Данное изделие обладает имеющей, силу контракта гарантией, покрывающей все возможные дефекты изготовления и материала. Гарантия вступает в силу с даты продажи изделия пользователю, из этого достаточно сохранить и предъявить полученный в кассе чек. Гарантия обязывает изготовителя заменить дефектные части изделия. В случае не соответствующего нормам использования изделия, несанкционированного демонтажа или ремонта или небрежного обращения действие гарантии прекращается. Гарантия не покрывает ущерба, возникшего в результате сбоя в работе изделия.

TU. GARANTI

Bu, arac, satis tarihinden itibaren, kullanıcının sâdece vezne alindisini sunmasiyla tum uretim ve malzeme hatasina karsi garantilidir. Garanti eksik olan kisimlari degistirmek icindir. Bu garanti aracin sartlarina uygun olmayan isleme durumunda, izih verilmeden kullanimlardan kaynaklanan hasarlarda veya alicinin istegi durumunda uygulanmaz. Garanti malzemenin bir eksikliginden meydana gelen bir zararda uygulanmaz.

CS. ZARUKA

Pro tento nástroj platí smluvní záruka na všechny výrobni a materiálové vady od data prodeje uživateli a na základe predložení pokladniho bloku. Záruka spocíva ve výmene vadnych casti. Táto záruka neplatí v prípade pouziti prístroje, ktoré neodpovedá normám, ani v prípade

škod způsobených nepovolenými zásahy nebo nedbalostí ze strany kupujícího. Záruka se nevztahuje na škody způsobené závadou nástroje.

SK. ZARUKA

Pre tento nástroj platí zmluvná záruka na všetky výrobne a materiálové chyby od dátumu predaja uživateli a na základe predloženia pokladničného bloku. Záruka spocíva vo výmene chybnych casti. Táto záruka neplatí v prípade pouzitia prístroja, ktoré neodpovedá normám, ani v prípade škod spôsobených nepovolenými zásahmi alebo nedbalosťou zo strany kupujúceho. Záruka sa nevztahuje na škody spôsobené poruchou nástroja

AR. الضمان

على مجرد تقديم نطاق الشراء يتعل في من تاريخ البيع الى المشتري وبيناً عيب فني التصني عوفى المواد. اعتراباً ان هذه الة ده مصنوعة شعاقدياً من أي الحوزان. ول في حالة تعرضه لتللفات حالة الاستخراة عي الطابق لم عيبري لا يولون هذا الضمان قابلاً للتطبيق فني لعل الضمان فاي سبدال الأجزاء الأعطالة لا يطبق الضمان على الضرور الناتج عن حرجرة أو فسي حالة الحول من قبل المشتري. نة حة عن عوليات تدخل غير

HU. GARANCIA

Erre a szerszámra szerződéses garanciát vállalunk bármilyen gyártási és anyaghiba felmerülése esetére, a fogyasztó részre történt eladás napjától számítva, a pénzérti blokk egysezeri felmutatása ellenében. A garancia a hibás alkatrészek cseréjére terjed ki. Ez a garancia nem érvényes, ha a keszuleket nem rendeltetésszerűen használták, sem illetékelen beavatkozások, vagy a vásárló hanyagsága okozta károk esetén. A garancia nem fedezi azokat a károkat, melyeket a szerszám hibás működése okozott.

SI. GARANCIJA

To orodje je z garancijsko pogodbo zasciteno proti vsem napakam v izdelavi in v sestavnem materialu od datuma prodaje naprej in ta velja ob predlozitvi blagajniškega racuna. Garancija velja za zamenjavo delov z napako. Ta garancija ne velja za uporabo orodja, ki ni v skladu z normami, predpisanimi za omenjeno orodje in za primere okvar, ki nastanejo zaradi nedovoljenih posegov na orodju ali zaradi malomarnega rokovanja kupca. Garancija ne velja za škodo, ki jo lahko povzroci okvara orodja.

ET. GARANTII

See toorist kuulub lepingu järgi garantiiremonti arvestades alates müumise päevast ja kassatseki alusel kasutajale koigi konstruktsiooniin ja materjalivigade puhul. Garantii seisneb defektsete osade välja vahetamises. See garantii ei kehti

aparaadi normide ebatavalise eiramise puhul ega ostja poolt keelatud viisil kasutamises või hooletusetaimsetest tulenevate kahjude korral. Garantii ei kehti seadme defektidest põhjustatud kahjude puhul

LV. GARANTĪJA

Šis prietaisys yra uztikrinamas kaip itin geros kokybes, nuo jo parduotimo datos iki jo panaudojimo, ir jam yra suteikiamas garantinis talonas. Garantijos metu galima pakeisti atsiradusius trumplaiškius gedimus. Ši garantija netaikoma esant netikamam naudojimui ar nesilaikant reikiamų šio aparato vartojimo instrukcijų, tai pat paciam pirkeiui ji sugadinus. Garantija taip pat netaikoma, prietaisą naudojant ne pagal paskirtį ir jį apgadinus

IT. GARANZIA

Sim darbarikam ir liguma noteikta garantija visiem defektuim, kas saistās ar konstrukciju un materiālu, sakot ar pardosanas datumu, kad masinru pardot lietotajam un vienkarši uzradot kases ceku. Garantija ieklavu bojato dalu nomainu. Ši garantija nav derīga, ja aparats nav lietots saskana ar drošības noteikumiem, ne gadijums ja bojājumi radusies nesankcionētas ietauksanas gadijuma vai arī pierceja holaidības del. Garantija nav derīga ja bojājumi radusies darbarika defekta del

HR. JAMSTVO

Ovaj alat ima ugovorno jamstvo u slučaju bilo kakvih nedostataka u konstrukciji i materijalu, od datuma prodaje korisniku uz jednostavno predocenje racuna. Jamstvo se sastoji u zamjeni neispravnih dijelova. Ovo se jamstvo ne primjenjuje u slučaju uporabe i eksploatacije koja nije sukladna standardima uredaja, niti u slučaju štete uzrokovane neovlaštenim intervencijama ili nemarom kupca. Jamstvo se ne primjenjuje na štetu uzrokovanu nekim nedostatkom alata.



FAR GROUP EUROPE

Une société du groupe **SIGMA**

192, Avenue Yves Farge
37700 St. Pierre-des-Corps
FRANCE

fartools.com

