



# CITY GREENHOUSE

Montagevejledning · Montageanleitung · Assembly instruction  
Instructions de montage · Montagehandleiding  
Instrucciones de montaje · Istruzioni de montaggio · Kokoamisohje



**KÆRE KUNDE!**

Tillykke med dit nye drivhus. Montagen af dit nye drivhus kræver, at du følger denne vejledning trin for trin.

Montagevejledningen er udarbejdet som en kombination af tekst og tegninger. Alle bolte, møtrikker og diverse fittings er samlet i en pose.

**VÆRKTØJ**

Til samling af drivhuset kræves en

- Fastnøgle i str. 10
- Fastnøgle i str. 17
- Stjerne skruetrækker
- Svensknøgle

**SIDE 5-7: MONTERINGSRÆKKEFØLGE**

Læg komponenterne op som vist på tegningen og saml derefter i den rækkefølge, billederne viser. Undlad at stramme møtrikkerne helt, før hele delkonstruktionen er samlet.

**FORSIKRING**

Vær opmærksom på, at ikke alle forsikringselskaber automatisk dækker glashuse. Kontakt dit forsikringselskab for at sikre forsikringsdækning.

**GARANTI**

Der ydes 12 års garanti, som dækker ombytning eller reparation af defekte dele. Garantien omfatter ikke polycarbonat, glas, transport, montage, fragt m.v. Der ydes 2 års garanti på eventuel lakering. Bemærk at der kan forekomme mærker i malingen, som stammer fra ophængning af profiler. Garantien bortfalder, hvis drivhuset ikke er monteret i overensstemmelse med denne vejledning.

**REKLAMATIONER**

Vi har strenge kvalitetskrav for at sikre dig et fejlfrit produkt. Skulle der alligevel være fejl eller mangler, så kontakt straks din forhandler. Husk at specificere manglen ved at oplyse drivhusmodel og komponentnummer samt kvalitetskontrolnummeret.

Eventuelle ophængs mærker samt blanke ender på lakerede Juliana profiler, vil ikke være synlige efter endt montage af huset.

Vi ønsker et stort tillykke med det nye drivhus, som vi håber vil bringe stor glæde i mange år fremover.

Med venlig hilsen

Juliana Drivhuse A/S

**DEAR CUSTOMER**

Congratulations on purchasing your new greenhouse. It is important that you follow these assembly instructions step-by-step.

The assembly instructions are a combination of text and illustrations. All nuts, bolts and fittings are contained in bag.

**TOOLS**

Assembling the greenhouse requires:

- Open-ended spanner, 10mm
- Open-ended spanner, 17mm
- Phillips screwdriver
- Adjustable spanner

**PAGE 5-7: ORDER OF ASSEMBLY**

Place the components as shown on the illustration and assemble in the order shown in the pictures. Do not tighten the nuts fully until the entire sub-frame has been assembled.

**INSURANCE**

Please note that not all insurance companies cover greenhouses automatically. Please contact your insurance company to ensure that your greenhouse is covered.

**GUARANTEE**

Juliana greenhouses are covered by a 12-year guarantee, which covers the replacement or repair of faulty parts. The guarantee does not cover polycarbonate, glass, transport, assembly, freight, etc.

Juliana greenhouses are covered by a two-year warranty on painted parts, where fitted. Note that marks on the paint may occur due to suspension of the profiles.

The guarantee will be void if the greenhouse is not assembled in accordance with these instructions.

**COMPLAINTS**

All our greenhouses are built to the highest quality standards. However, should you experience any problems, please contact your dealer at once. When describing the defect, please state the greenhouse model, the component number and the quality control number.

Any suspension marks or shiny ends on painted Juliana profiles will not be visible after the greenhouse has been assembled.

Congratulations on your new greenhouse, which we hope will bring you a lot of pleasure for many years to come.

Yours sincerely,

Juliana Drivhuse A/S

**D**

## Wir gratulieren Ihnen zu Ihrem neuen Gewächshaus

### SEHR GEEHRTER KUNDE!

Wir gratulieren Ihnen zu Ihrem neuen Gewächshaus. Zur Montage des Gewächshauses folgen Sie bitte gewissenhaft Schritt für Schritt dieser Montageanleitung.

Die Anleitung ist eine Kombination von Text und Zeichnungen. Montagebolzen, Muttern sowie die diversen Montagebeschläge finden Sie in Beutel.

### WERKZEUG

Zur Gewächshausmontage brauchen Sie

- Schraubenschlüssel, Gr. 10
- Schraubenschlüssel, Gr. 17
- Kreuzschlitzschraubendreher
- Rollgabelschüssel

### SIETE 5-7: MONTAGEREIHENFOLGE

Legen Sie die Komponenten wie in der Zeichnung dargestellt bereit und montieren Sie sie in der abgebildeten Reihenfolge.

Ziehen Sie die Schraubenmutter erst dann ganz fest, wenn die gesamte Teilkonstruktion montiert ist.

### VERSICHERUNG

Wir weisen darauf hin, dass nicht alle Versicherungen automatisch Gewächshäuser abdecken. Fragen Sie bei Ihrer Versicherung nach.

### GARANTIE

Es werden 12 Jahre Garantie geleistet, die Austausch oder Reparatur defekter Teile deckt. PC-Stegplatten, Glas, Transport, Montage, Fracht und dgl. sind nicht in der Garantie enthalten.

Auf eventuelle Lackierungen werden zwei Jahre Garantie geleistet. Beachten Sie, dass Kratzer im Lack durch die Aufhängung der Profile möglich sind. Die Garantie entfällt, wenn das Haus nicht gemäß dieser Montageanleitung montiert wurde.

### REKLAMATIONEN

Wir haben strenge Qualitätsansprüche, um Ihnen ein fehlerfreies Produkt zu sichern. Sollten trotzdem Fehler oder Mängel auftreten, wenden Sie sich umgehend an Ihren Händler. Beschreiben Sie genau den Mangel und geben Sie Gewächshausmodell, Komponentenummer und Qualitätskontrollnummer an.

Eventuelle Aufhängemarkierungen sowie freie Enden von lackierten Juliana-Profilen sind nach beendeter Montage des Gewächshauses nicht mehr sichtbar.

Wir gratulieren Ihnen zu Ihrem neuen Gewächshaus, das Ihnen hoffentlich viele Jahre lang Freude machen wird.

Mit freundlichem Gruß,

Juliana Drivhuse A/S

**S**

## Lycka till med Ert nya växthus

### BÄSTA KUND!

Grattis till ditt nya växthus. För att kunna montera ditt nya hus måste du följa den här bruksanvisningens steg för steg.

Monteringsanvisningarna är en kombination av text och illustrationer. Alla skruvar, muttrar och diverse smådelar är samlade i påse.

### VERKTYG

För montering av växthuset krävs de verktyg

- Skruvnyckel i stl. 10
- Skruvnyckel i stl. 17
- Stjärneskruvmejsel
- Skiftnyckel

### SIDA 5-7: MONTERINGSORDNING

Lägg upp komponenterna och montera därefter i den ordning som bilden visar. Undvik att spänna skruvarna helt förrän hela delkonstruktionen är monterad.

### FÖRSÄKRING

Var uppmärksam på att inte alla försäkringsbolag automatiskt försäkrar växthus. Kontakta ditt försäkringsbolag och teckna försäkring.

### GARANTI

Växthuset har 12 års garanti som täcker byte eller reparation av defekta delar. Garantin täcker inte polykarbonat, glas, transport, montering, frakt m.m. Det är 2 års garanti vid eventuell lackering. Tänk på att det kan förekomma märken i lackeringen som kommer från uppsättningen av profilerna. Garantin gäller inte om växthuset inte monteras enligt dessa anvisningar.

### REKLAMATIONER













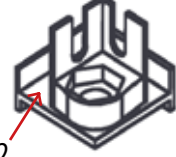
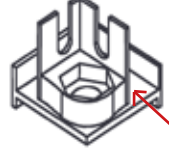

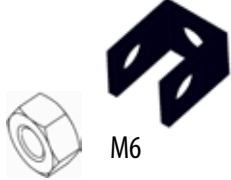



Vi har höga kvalitetskrav för att säkerställa en felfri produkt. Om du ändå hittar fel eller om det saknas delar ska du kontakta din återförsäljare på en gång. Kom ihåg att specificera felet genom att lämna information om växthusmodell, komponentnummer och kvalitetskontrollnummer.













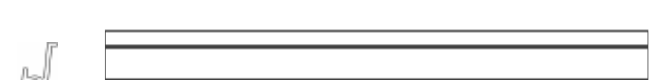





Eventuella upphängningsmarkeringar samt blanka ändrar på lackade Juliana-profiler kommer inte att synas när huset har slutmonterats.

Stort grattis till det nya växthuset. Vi hoppas att det kommer att innebära mycket glädje i många år framöver.

Med vänlig hälsning

Juliana Drivhuse A/S

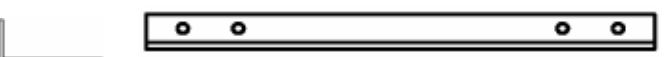
<p>8x 28</p> 	<p>4x 93-1</p> 	<p>6x 27</p> 	<p>2x 508</p> 	<p>2x 509</p> 
<p>1x 77</p> 	<p>1x 73</p> <p>M6</p> 	<p>1x 73E</p> 	<p>1x 78B 73D</p> 	<p>5x M10</p> 
<p>4x 664</p> 	<p>1x 73B</p> 	<p>88x 80</p> 	<p>2x 84</p> 	<p>90 79</p> 
<p>1x 052</p> <p>1363MM</p> 	<p>1x 05</p> <p>1488MM</p> 	<p>1x 053</p> <p>1363MM</p> 	<p>1x 051</p> <p>1488MM</p> 	<p>1x 01</p> <p>1088MM</p> 

<p>1X 10</p>  <p>800MM</p>	<p>1X 20</p>  <p>798MM</p>	
<p>1X 01-1</p>  <p>331MM</p>	<p>1X 22</p>  <p>798MM</p>	
<p>2X 01-2</p>  <p>727MM</p>	<p>2X 21</p>  <p>393MM</p>	
<p>3X 25</p>  <p>777MM</p>	<p>2X 29</p> 	<p>90X 280</p> 
<p>4X 01-3</p>  <p>326MM</p>	<p>1X 23</p>  <p>200MM</p>	<p>10X TRÆ</p> 
<p>1X 021</p>  <p>345MM</p>	<p>1X 512</p> 	<p>1X 511</p> 
<p>1X 02</p>  <p>345MM</p>	<p>1X 360MM</p> 	<p>1X 760MM</p> 
<p>4X 30</p>  <p>320MM</p>	<p>2X 364</p> 	<p>2X 363</p> 

**4 mm. - Hærdet glas - Tempered glass - Sicherheitsglas - Härdet glas**

2X #D - 942 X 378MM      2X #A - 1097 X 366MM      2X #G - 1066\940,8 X 344MM

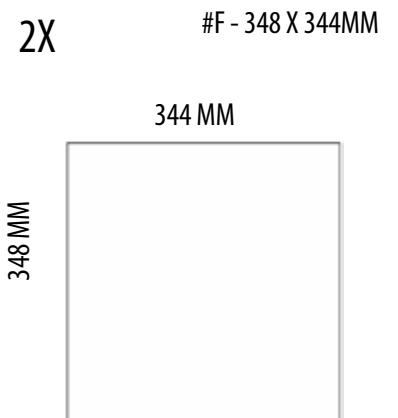
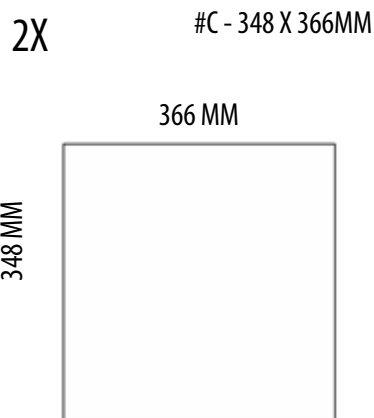
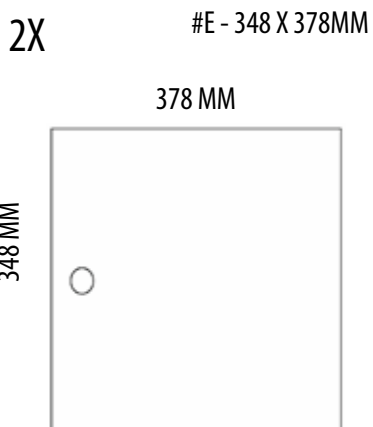
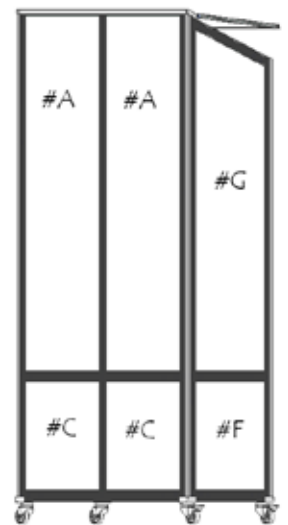
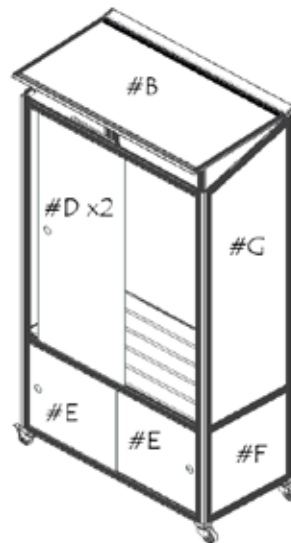
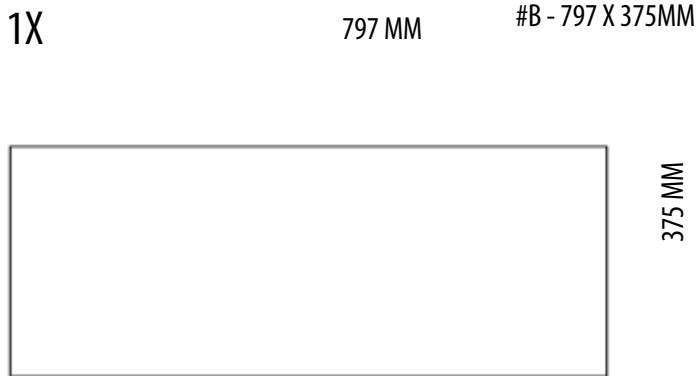
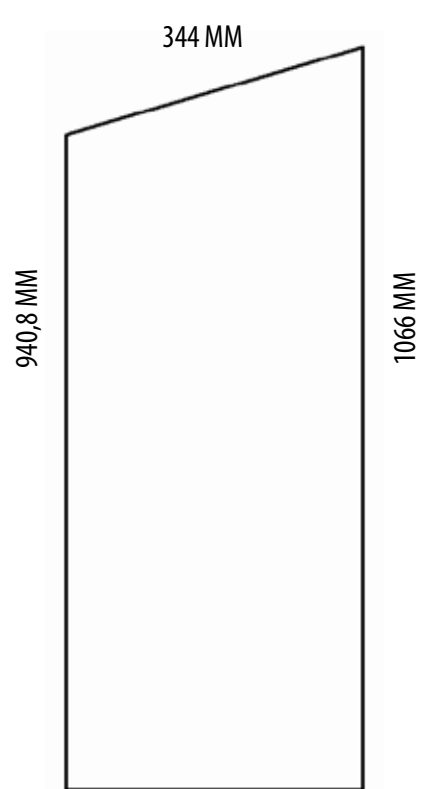
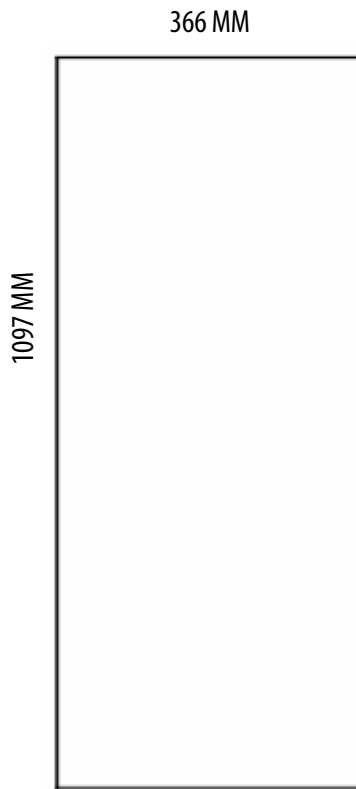
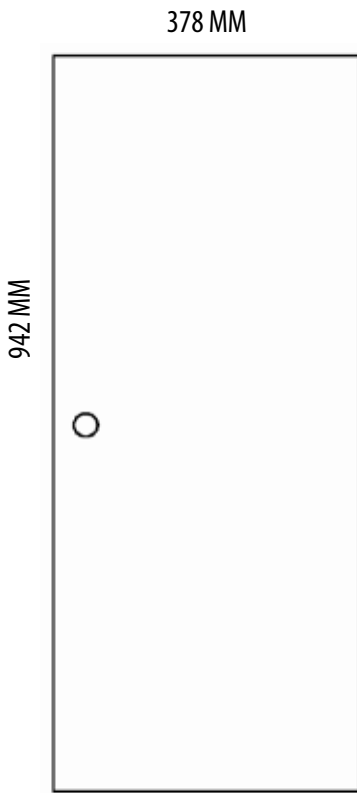

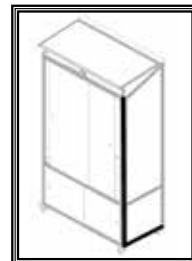

1

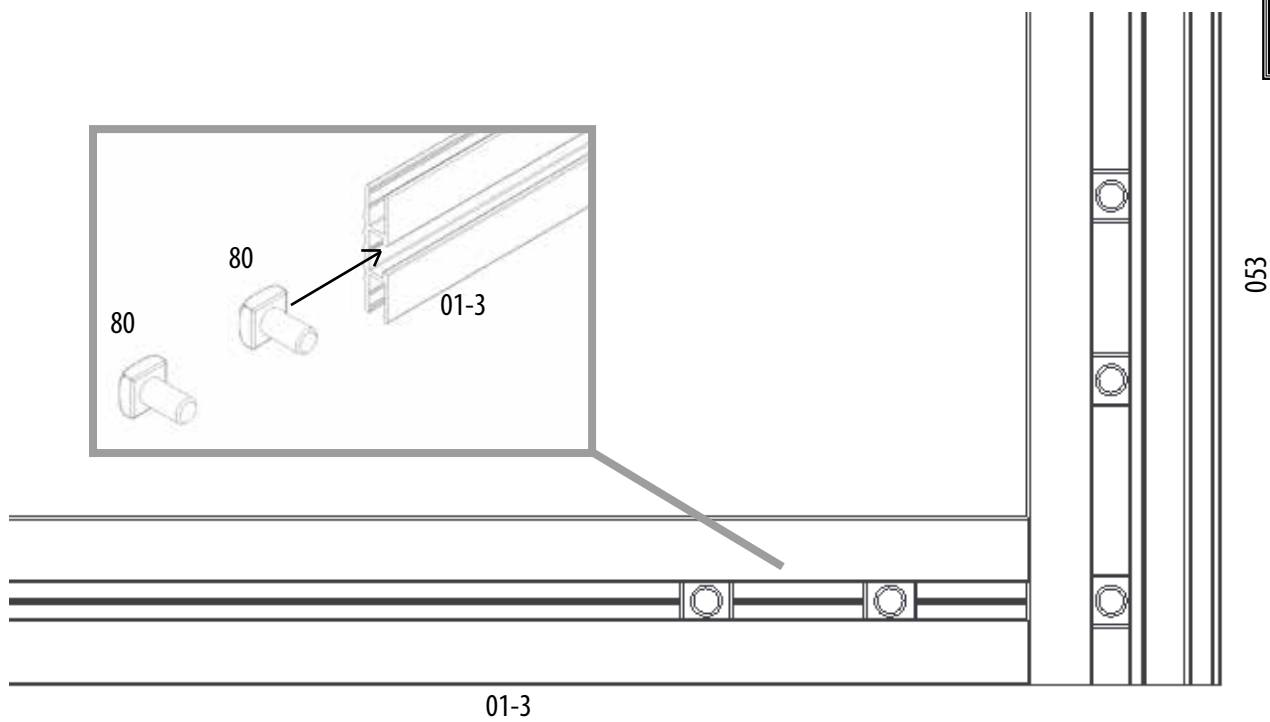

2

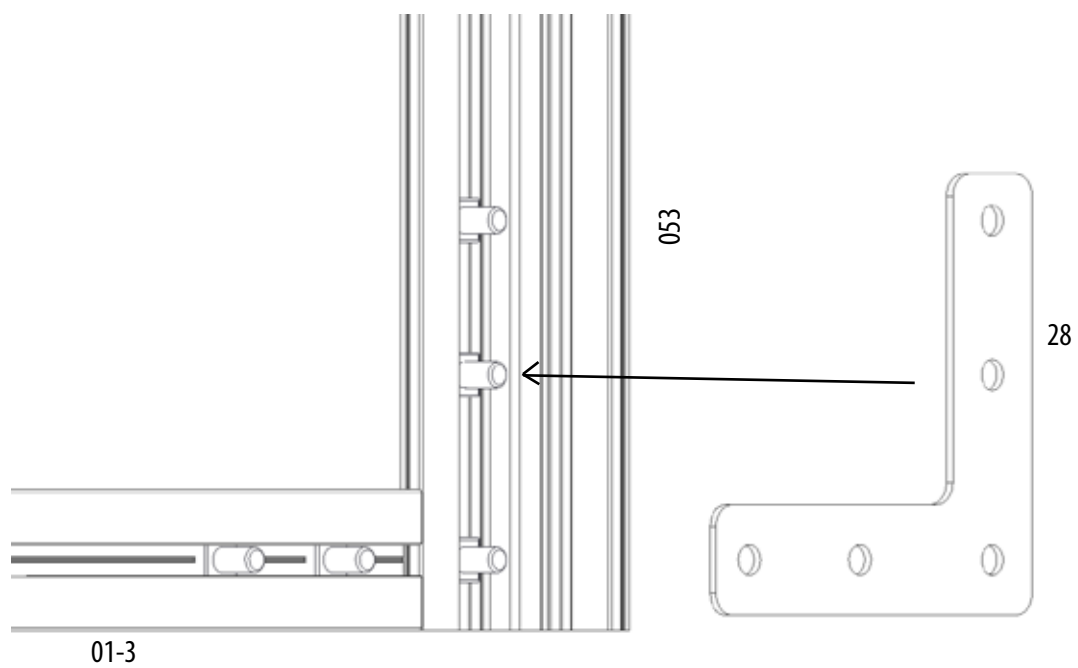



# 3

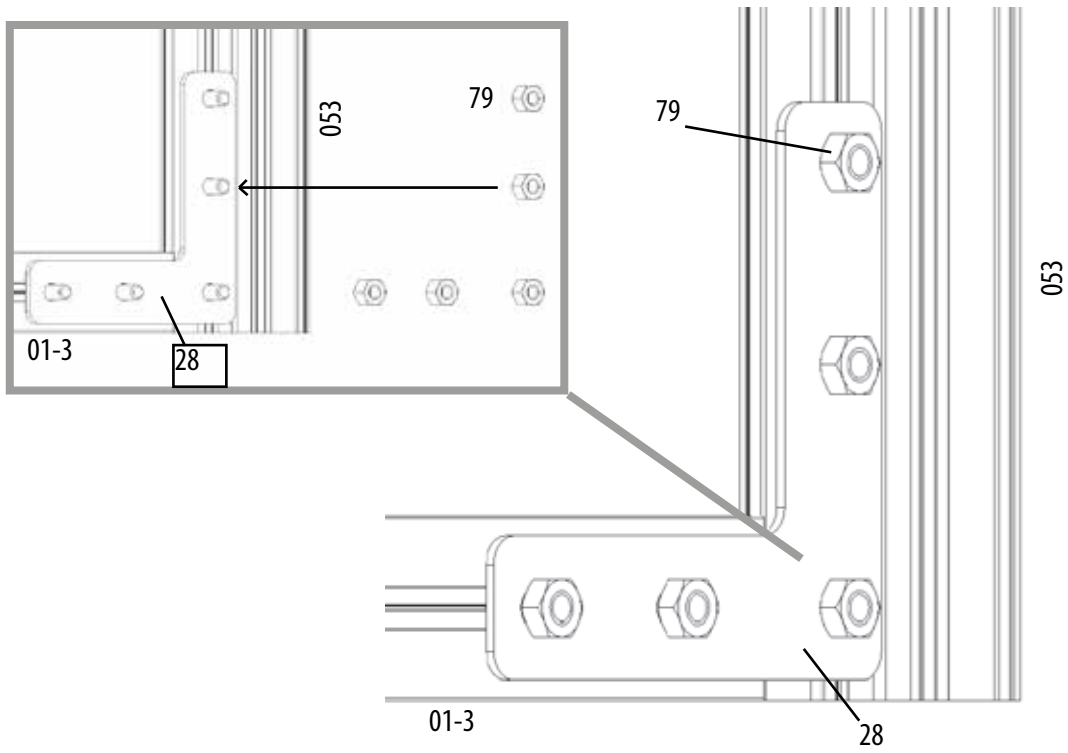

# 4

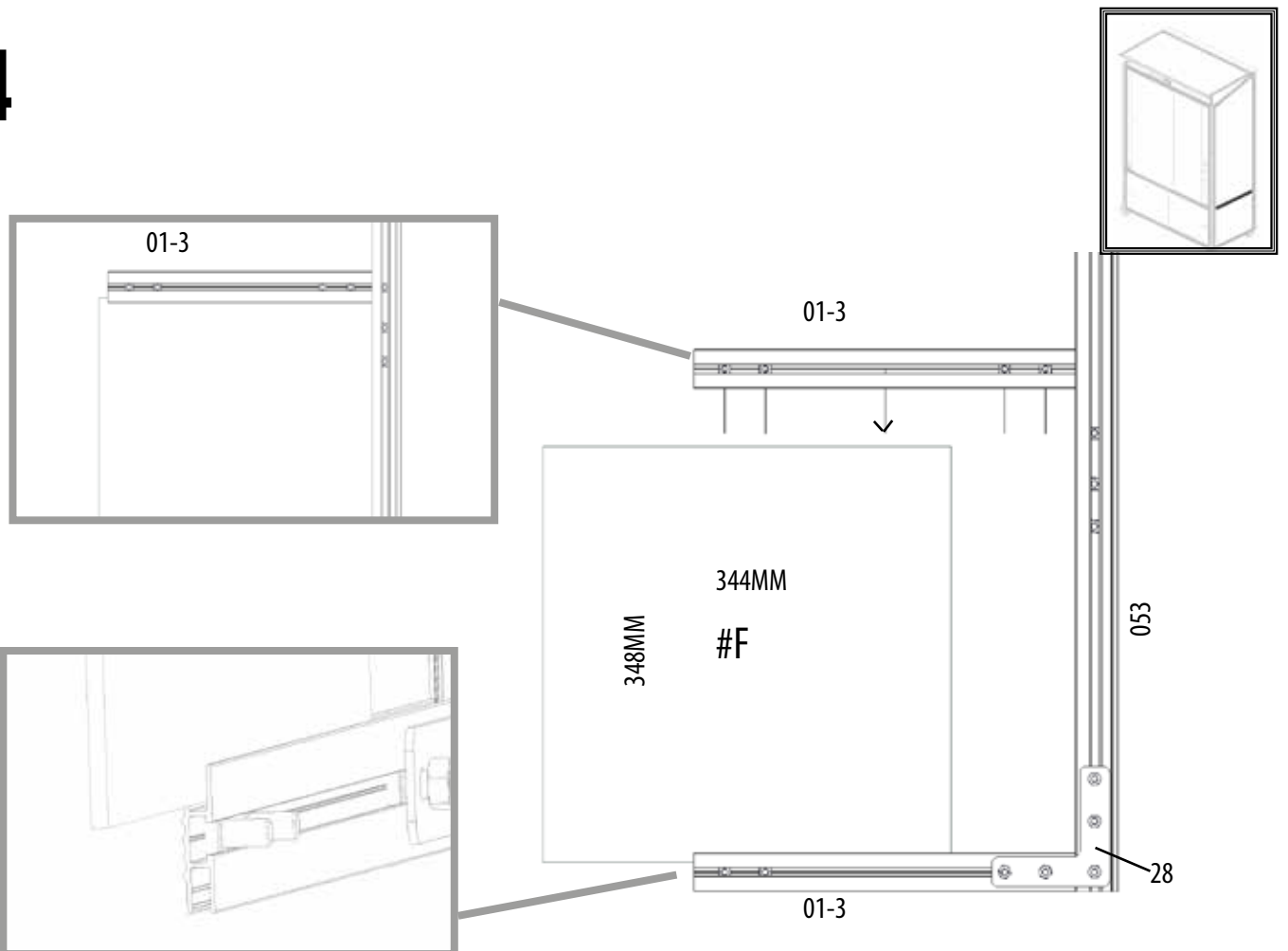

# 5

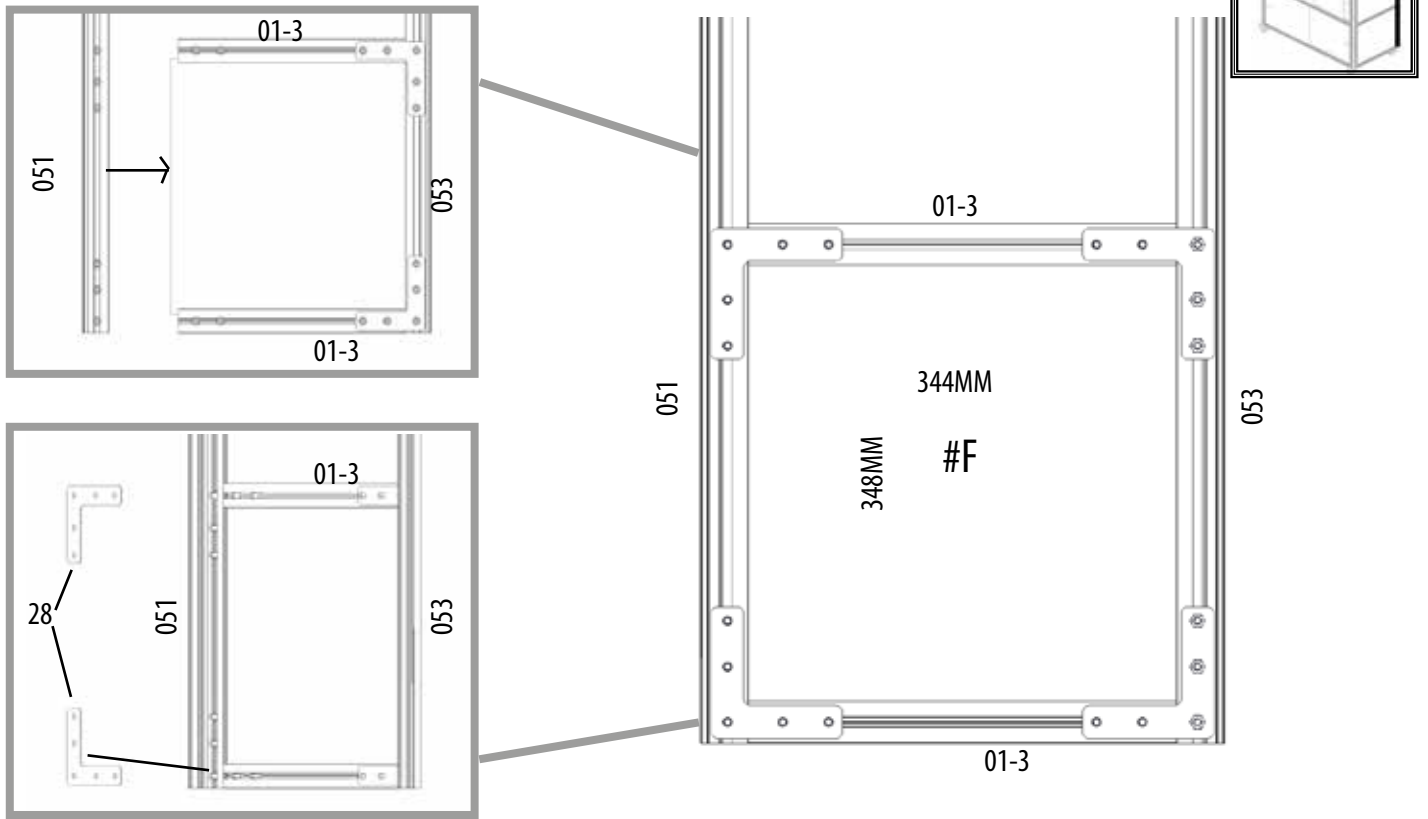

# 6

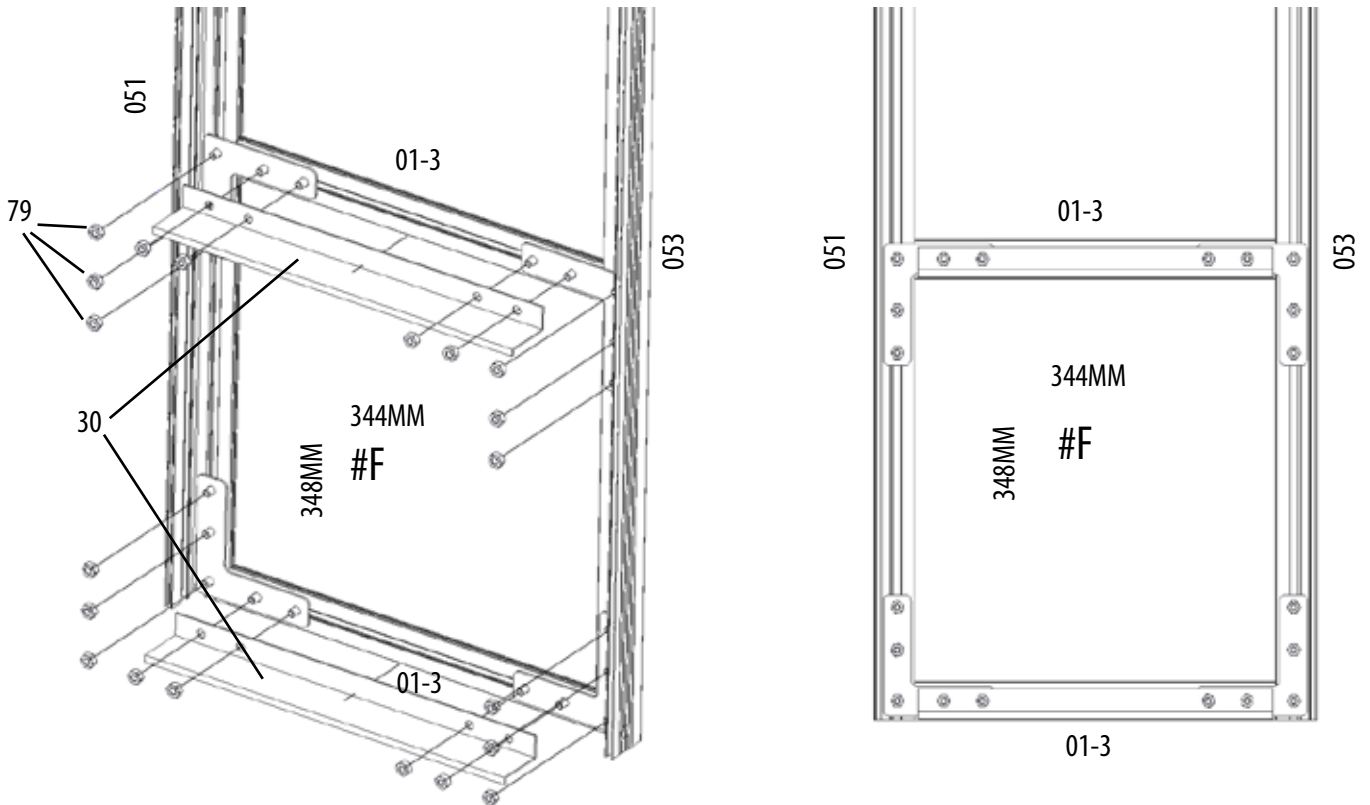

# 7

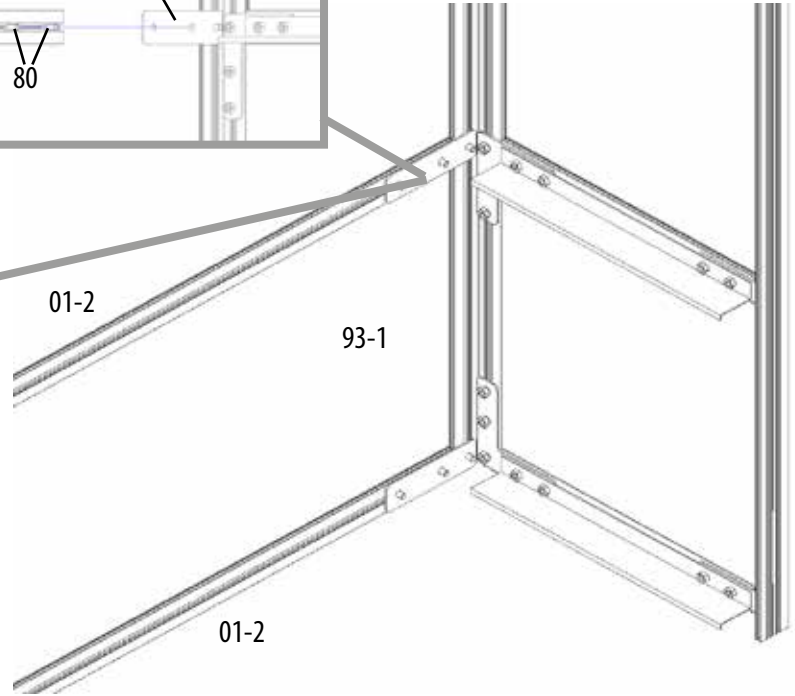
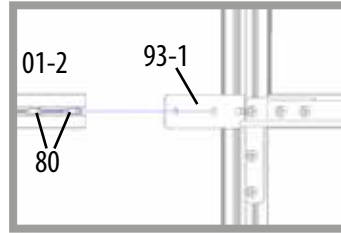
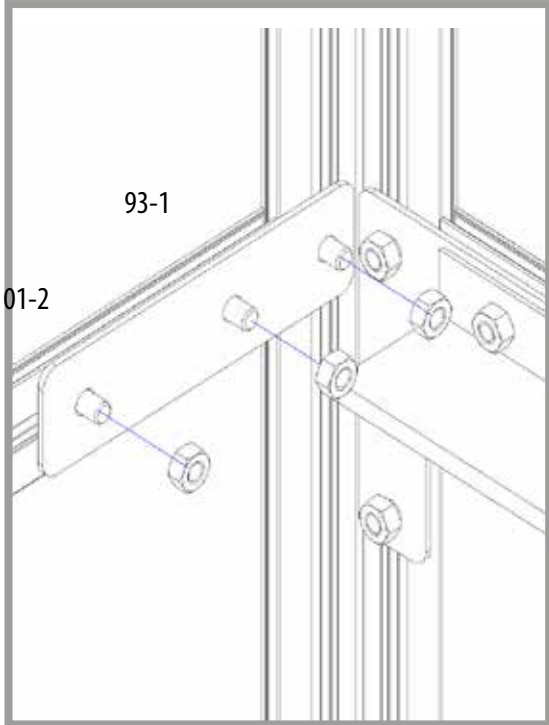
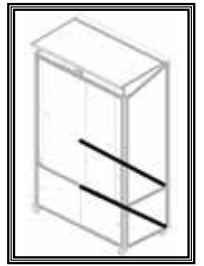

# 8

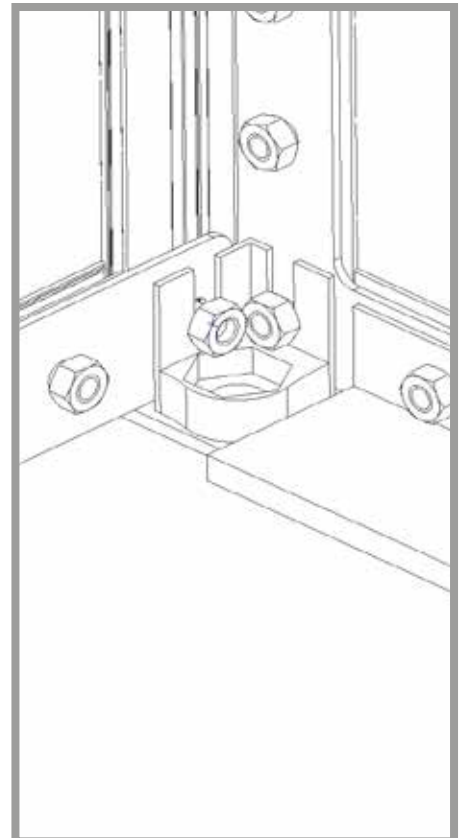
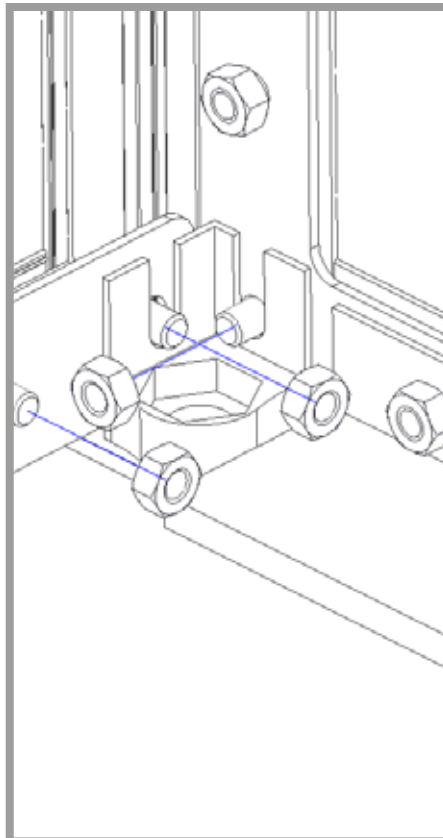
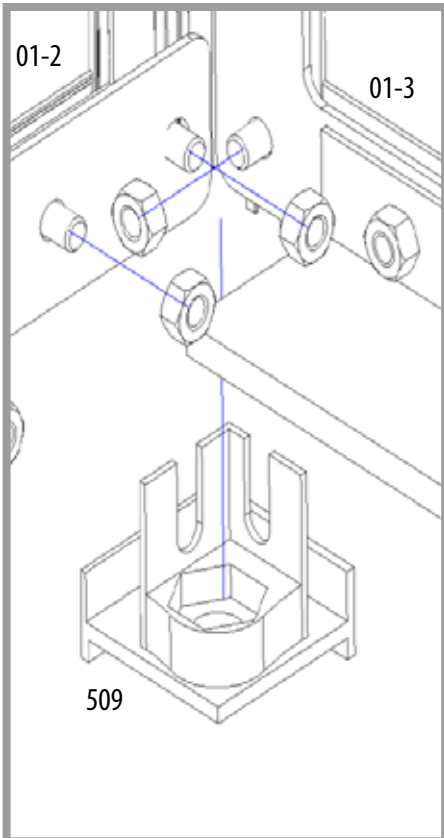

# 9

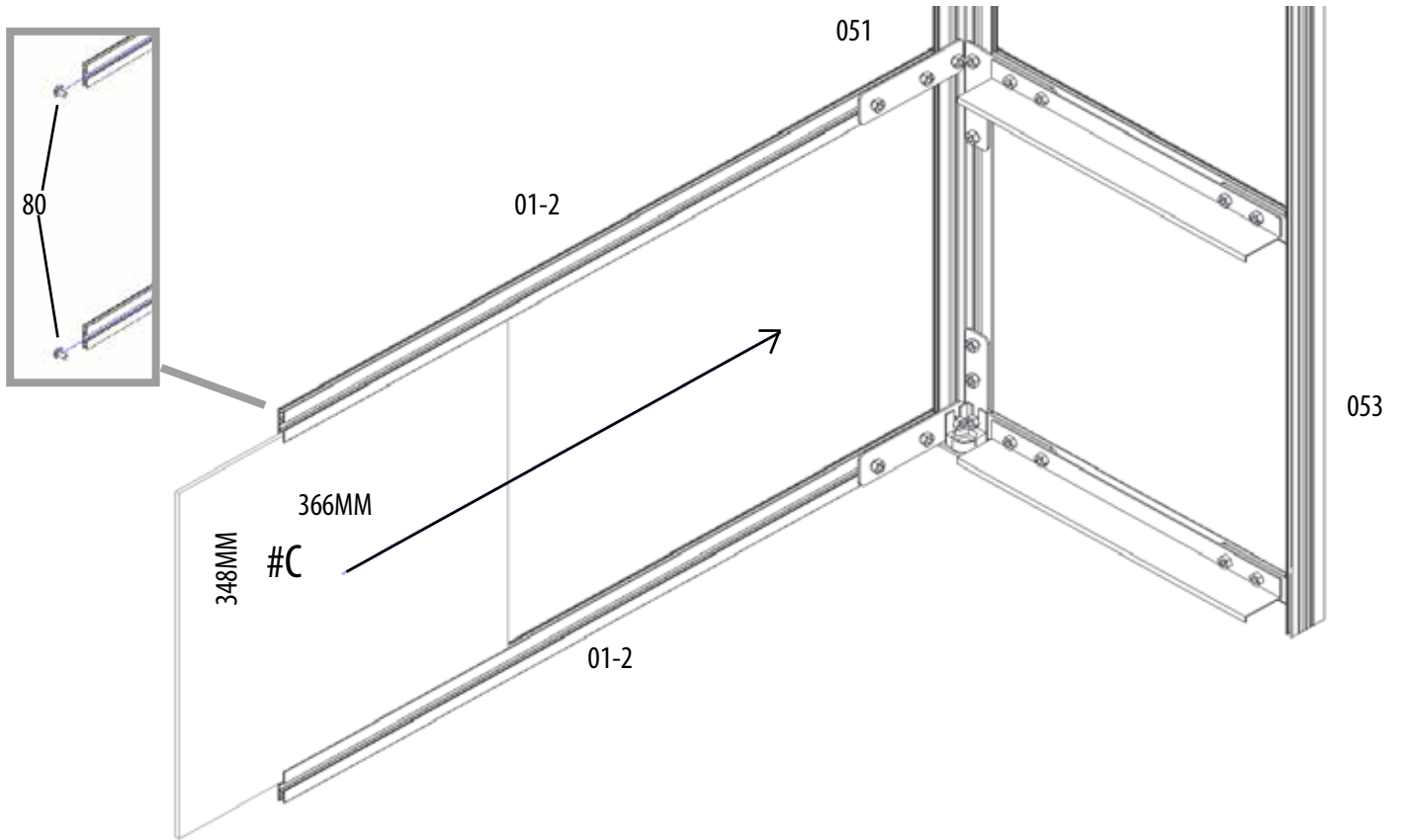

# 10

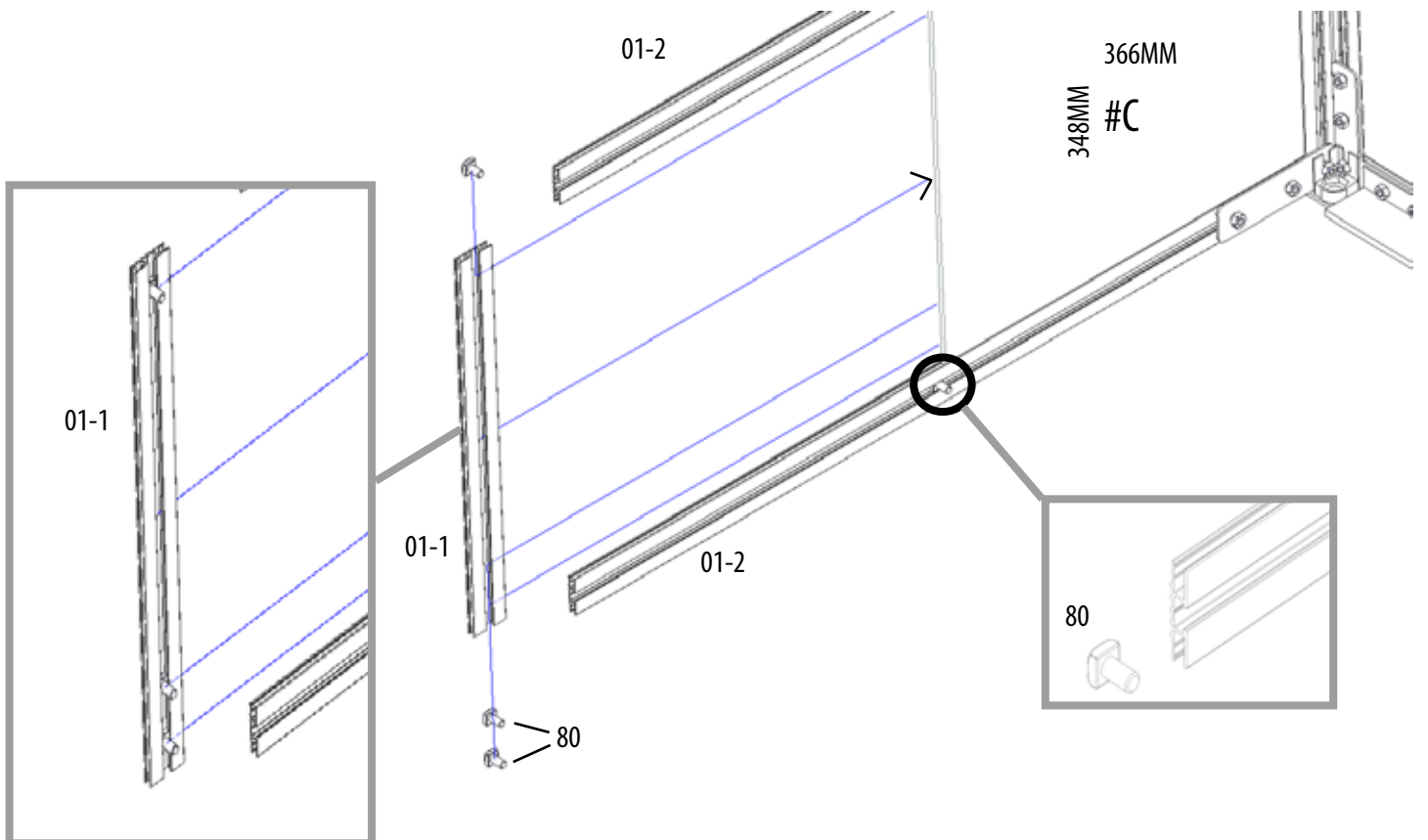

# 11

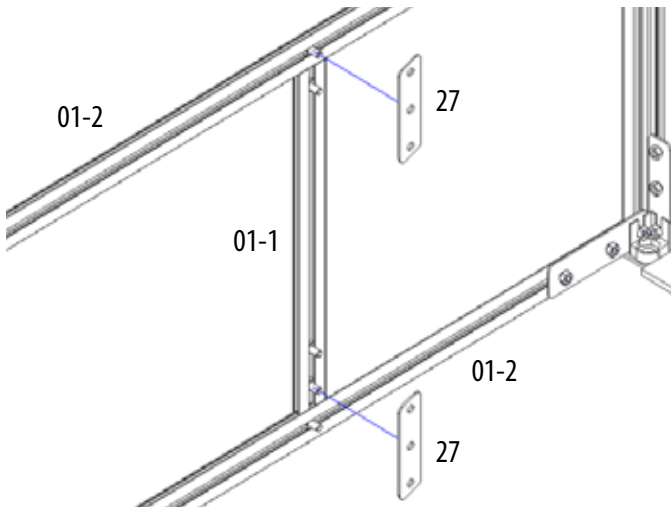

# 12

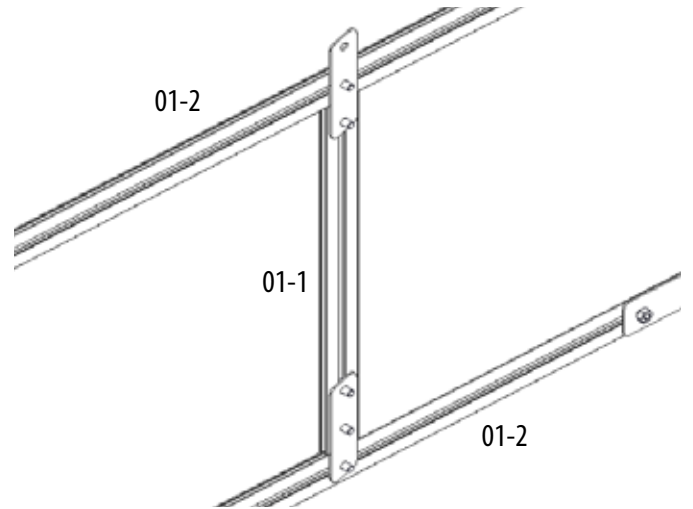

# 13

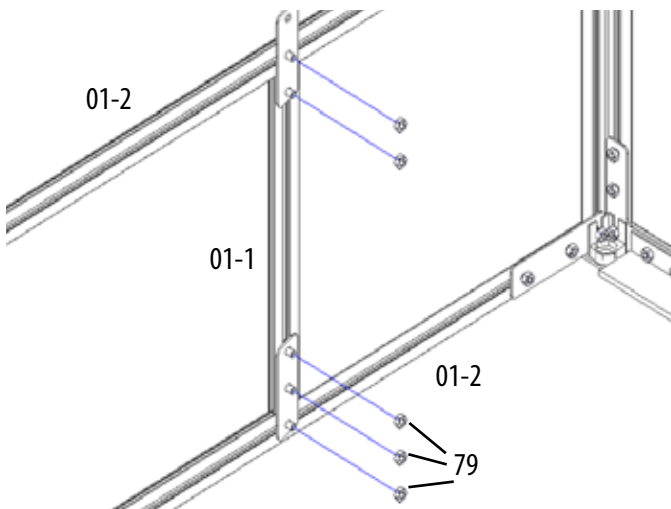

# 14

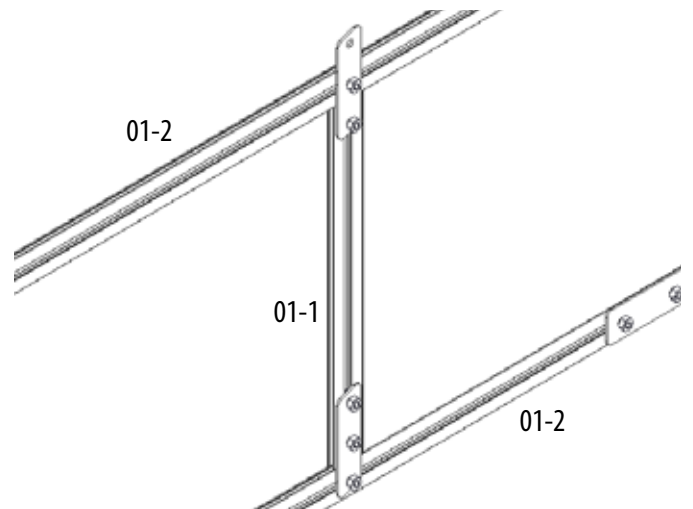

# 15

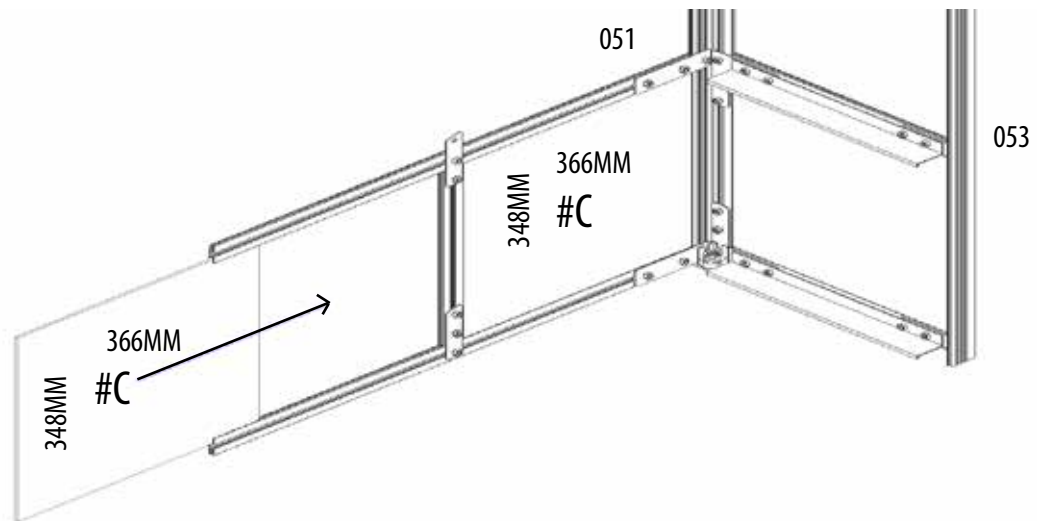

# 16

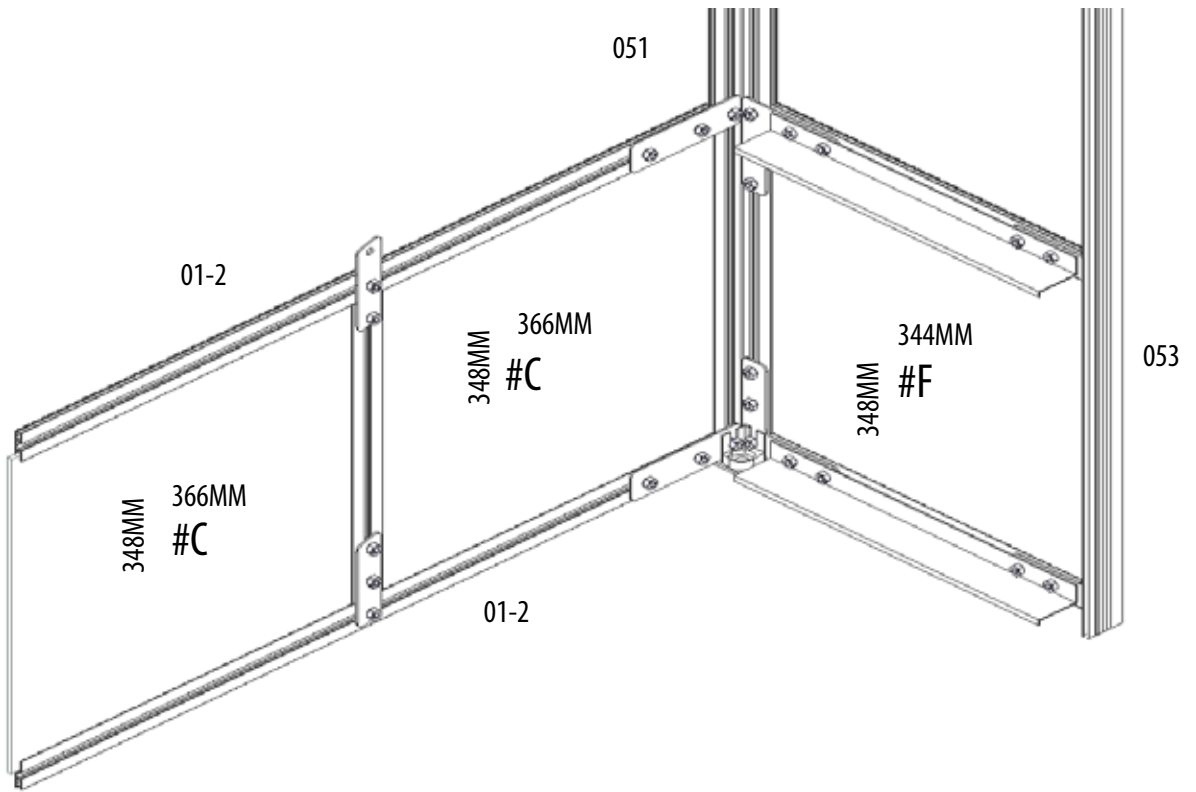

# 17

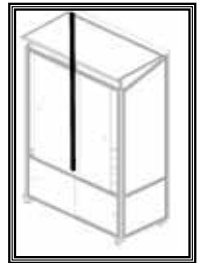
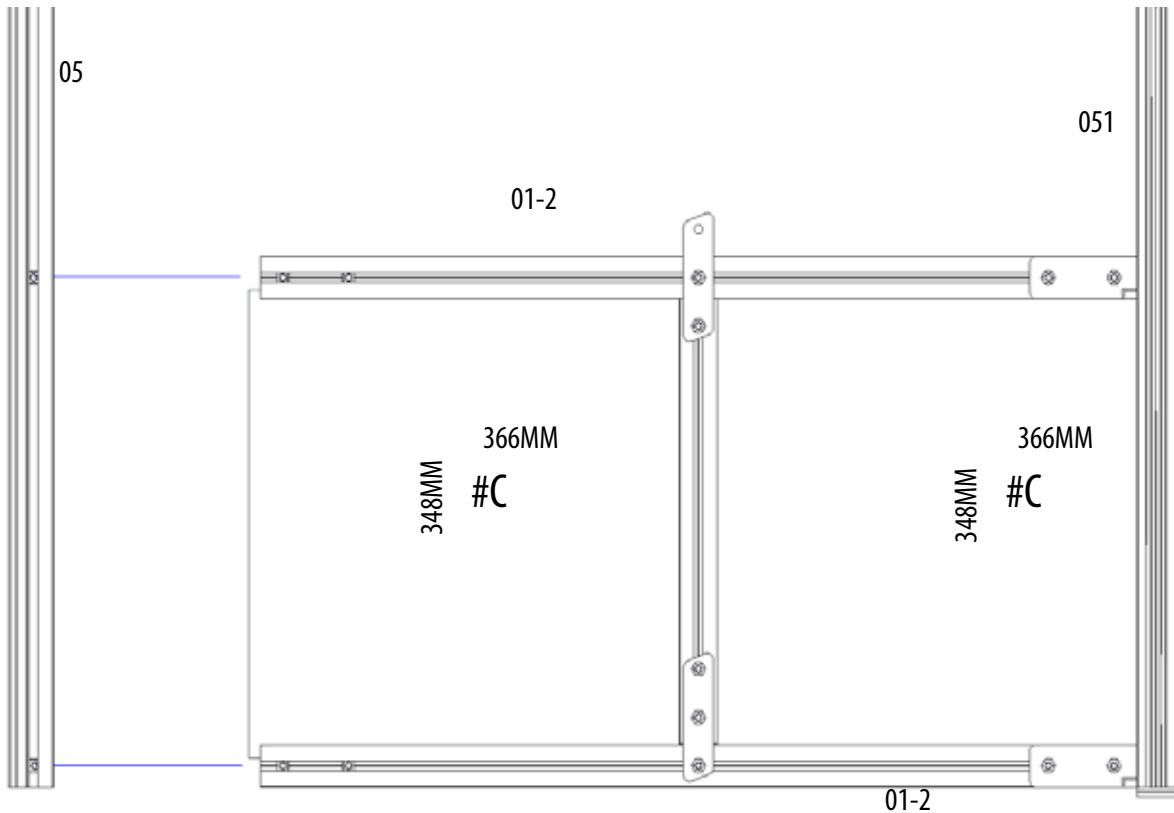

# 18

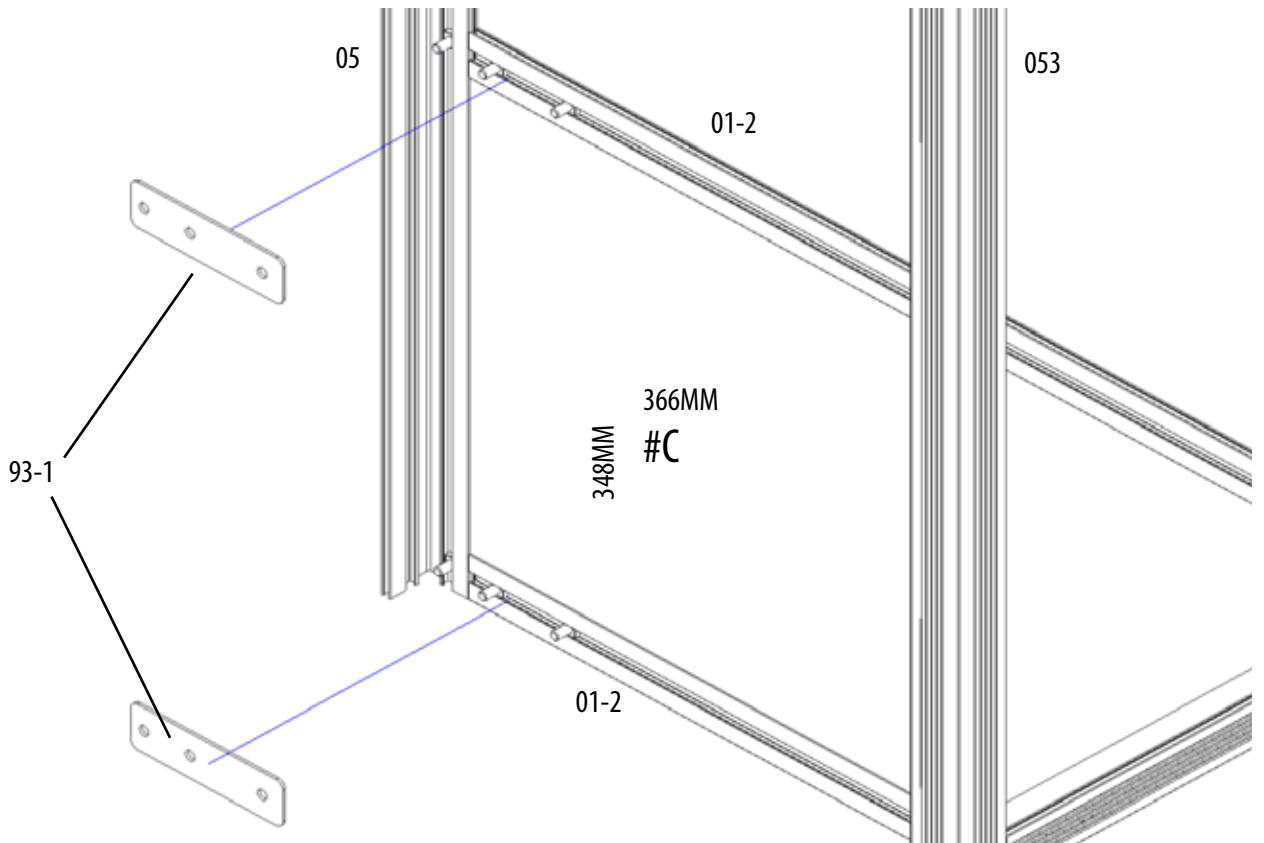

# 19

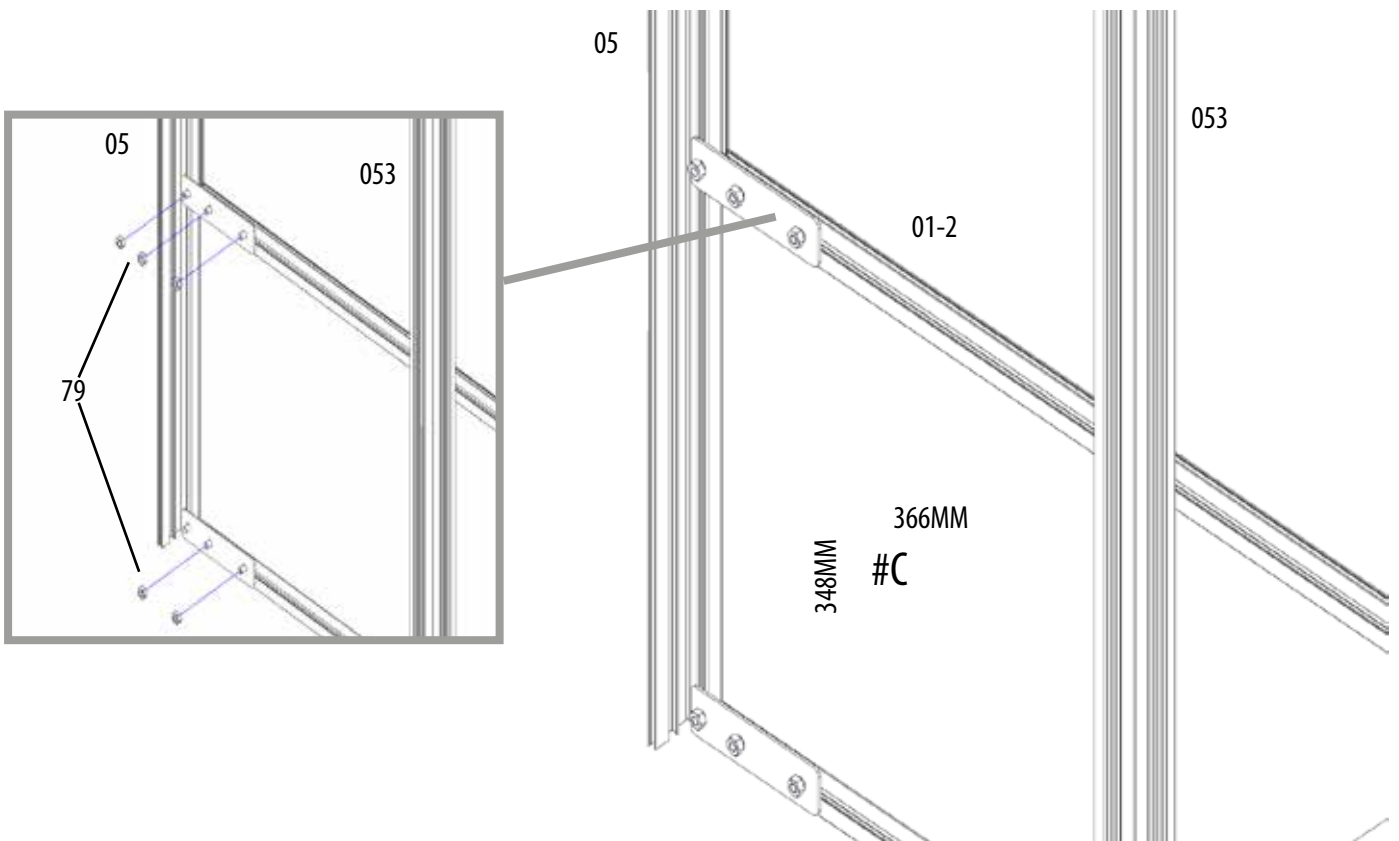

# 20

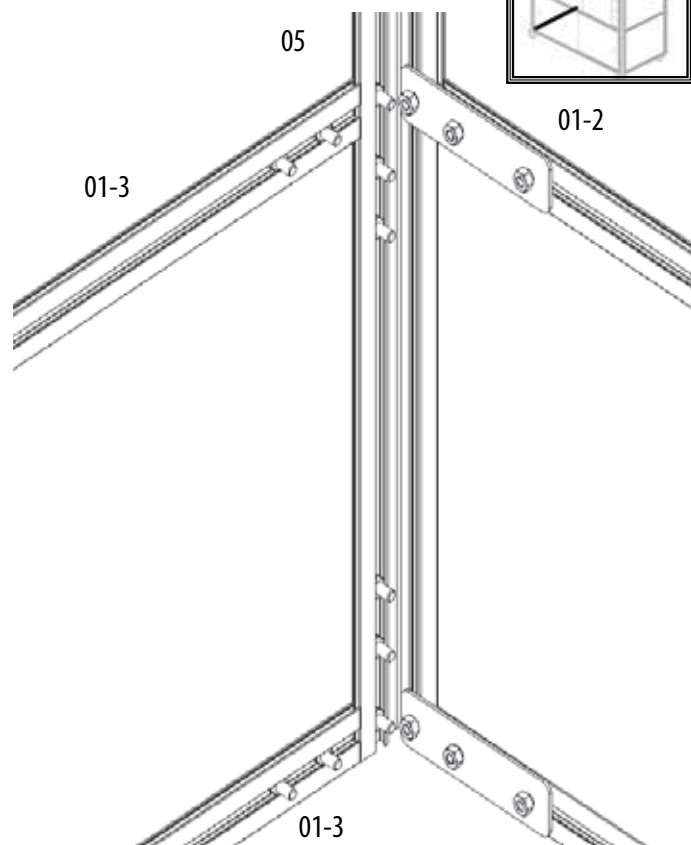
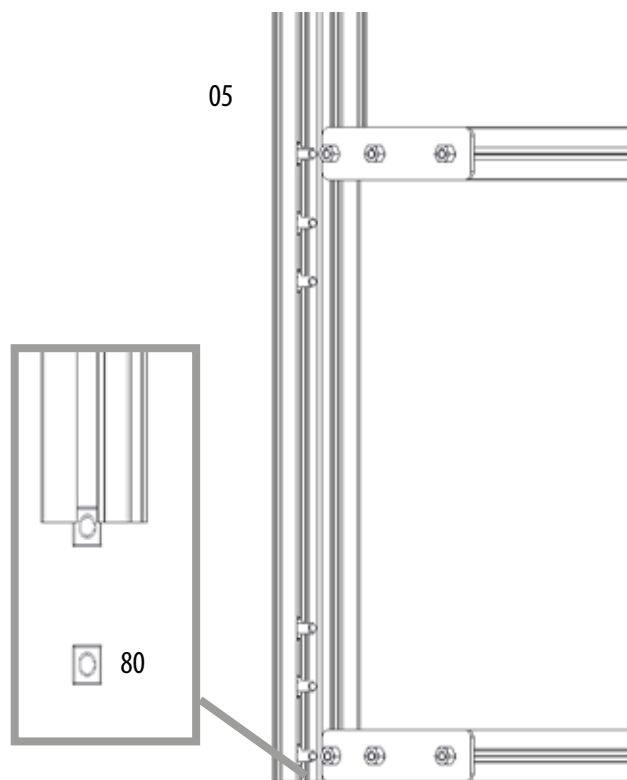

# 21

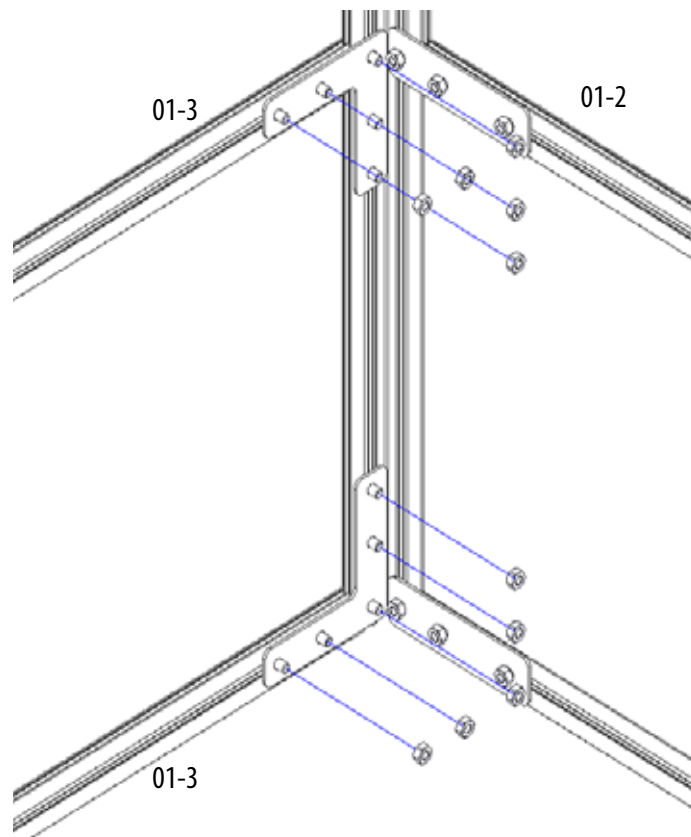
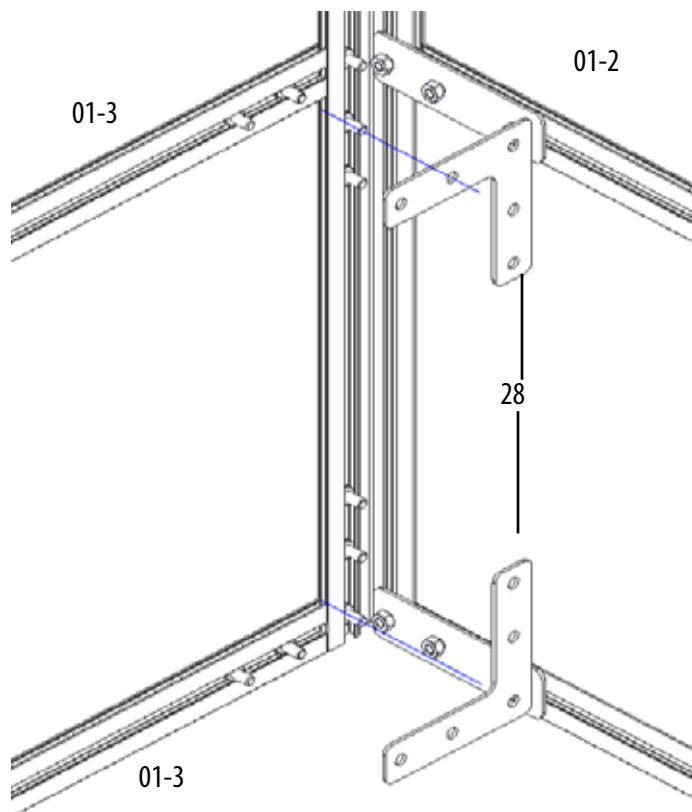



# 22

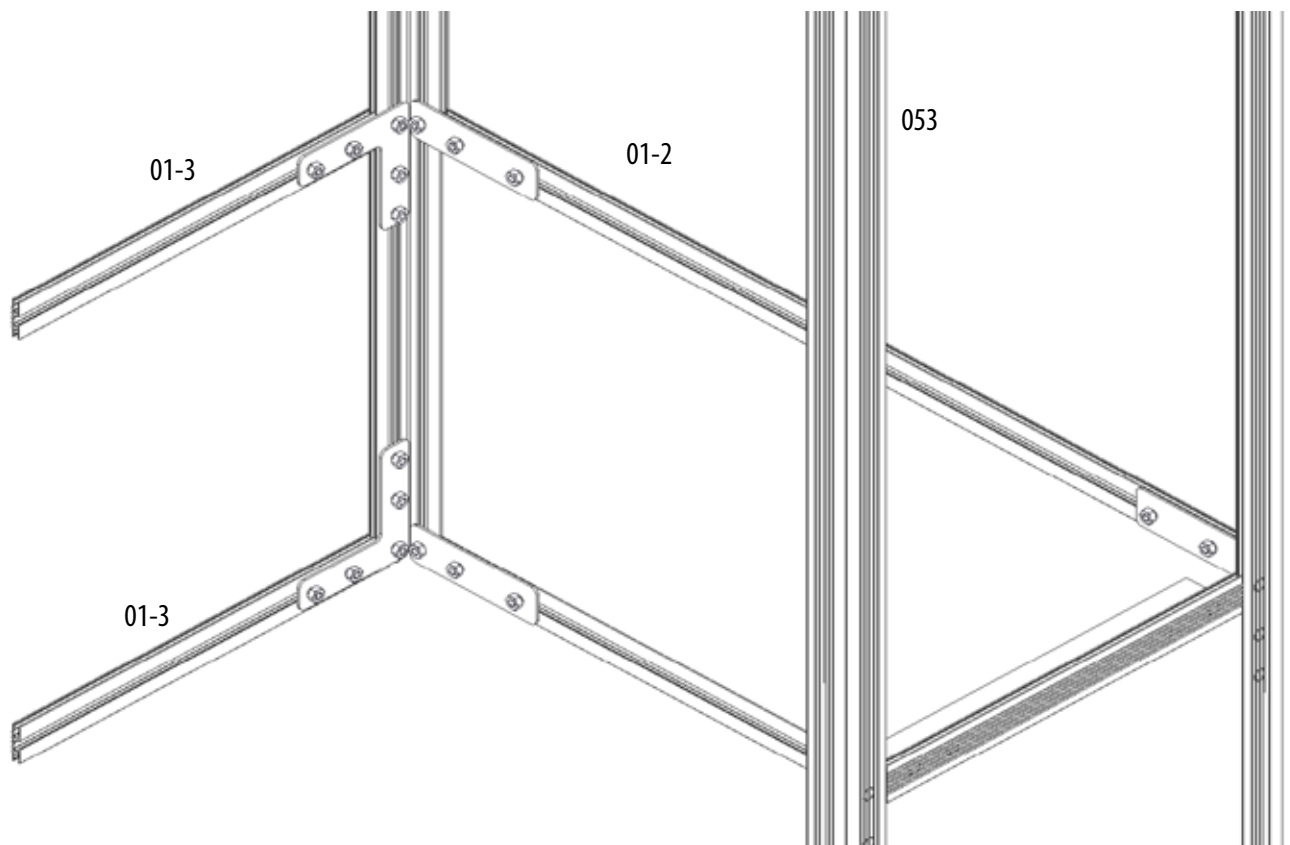

# 23

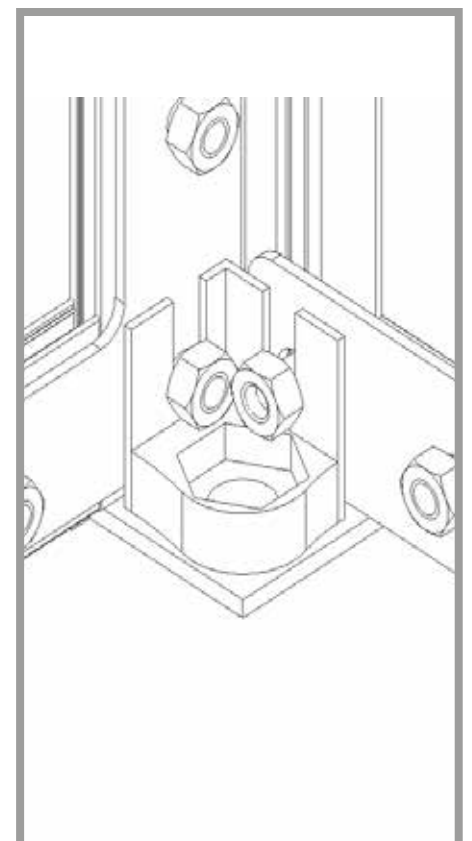
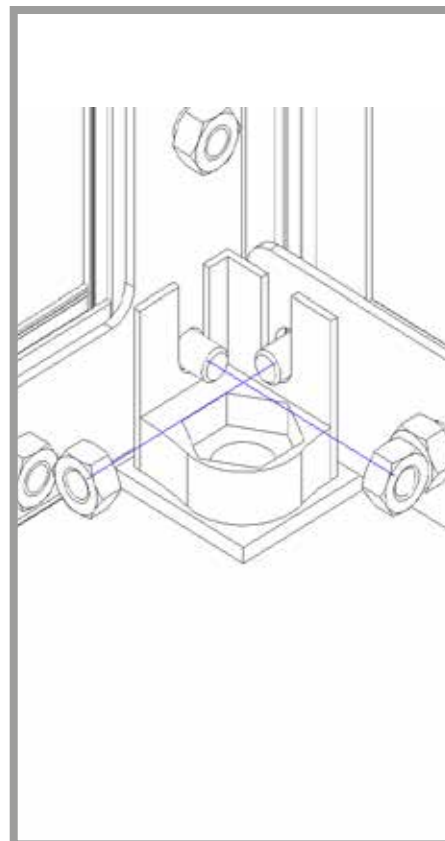
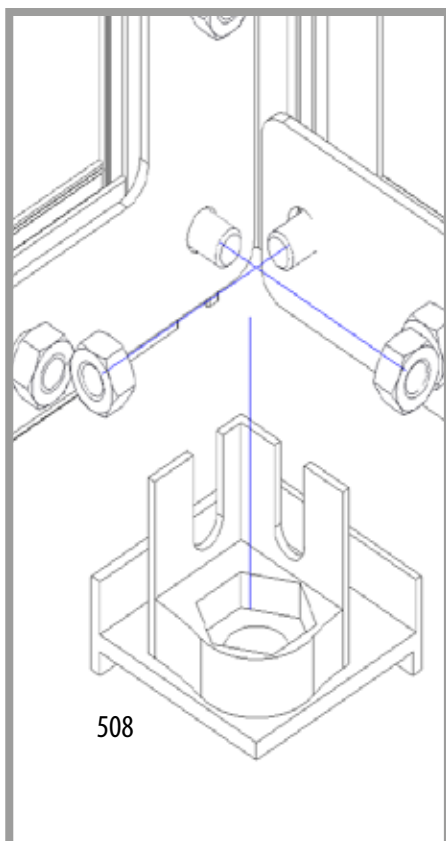

# 24

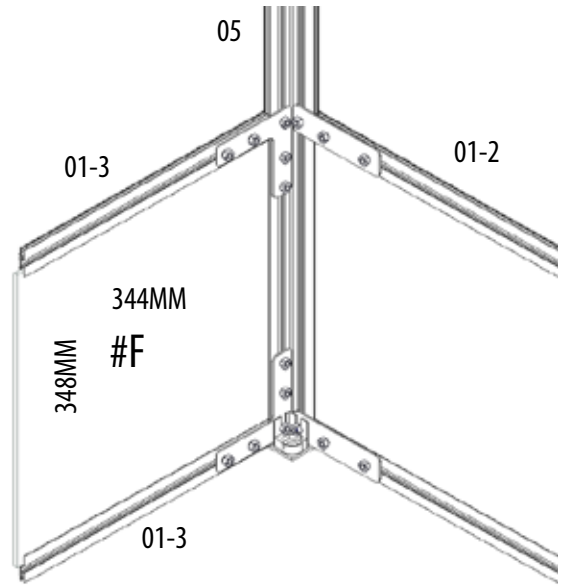
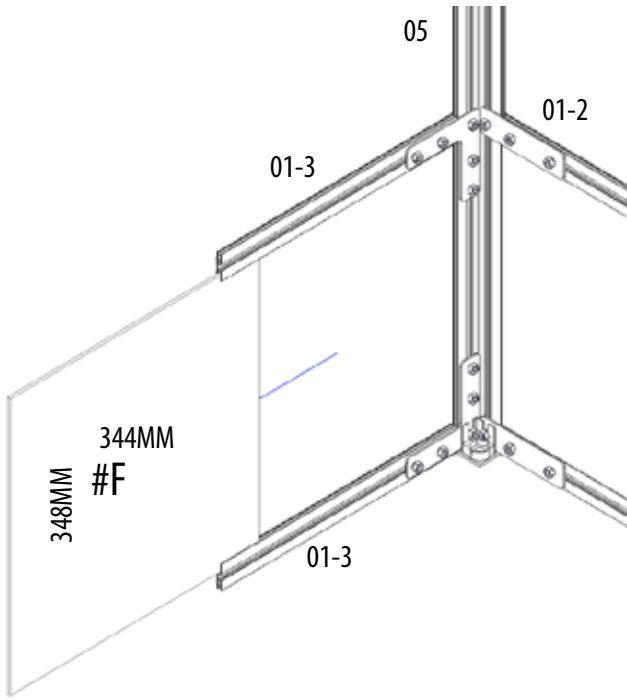

# 25

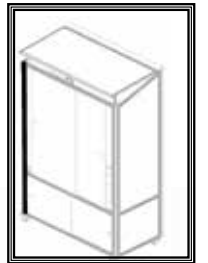
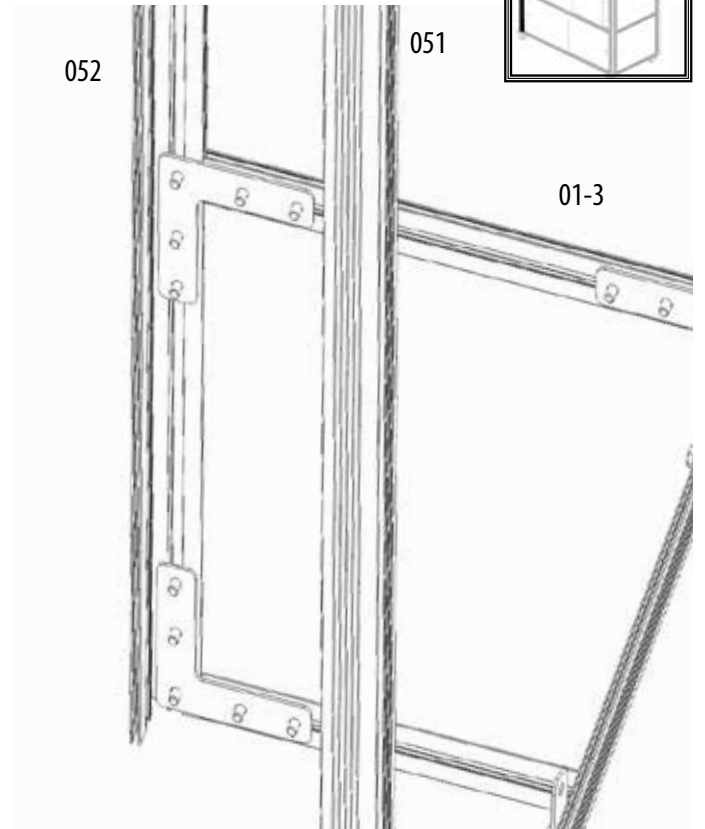
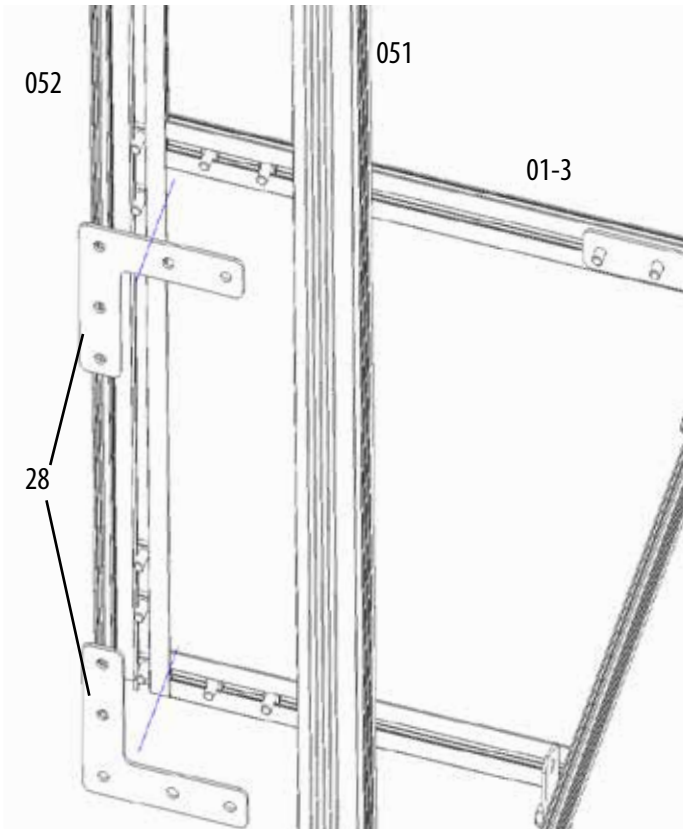

# 26

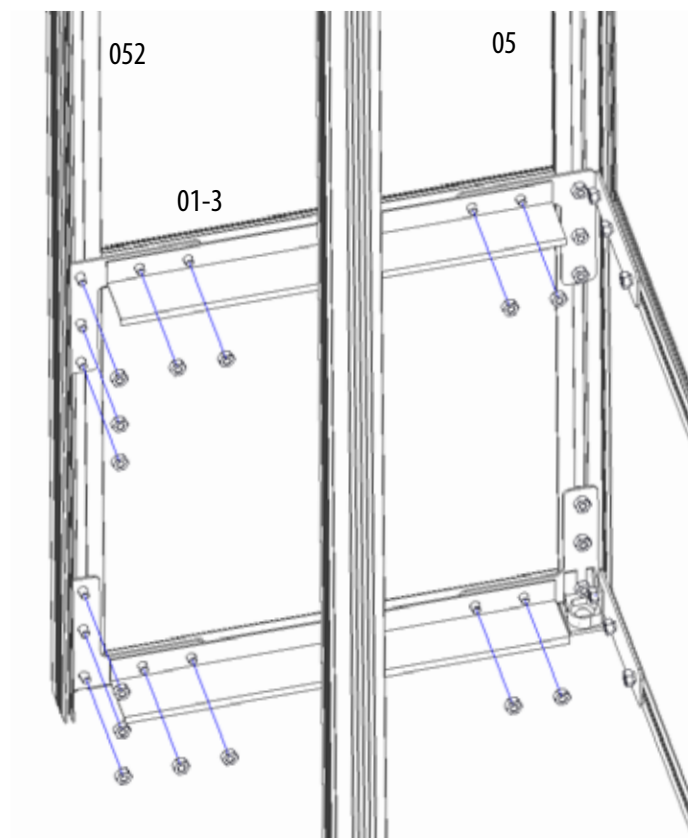
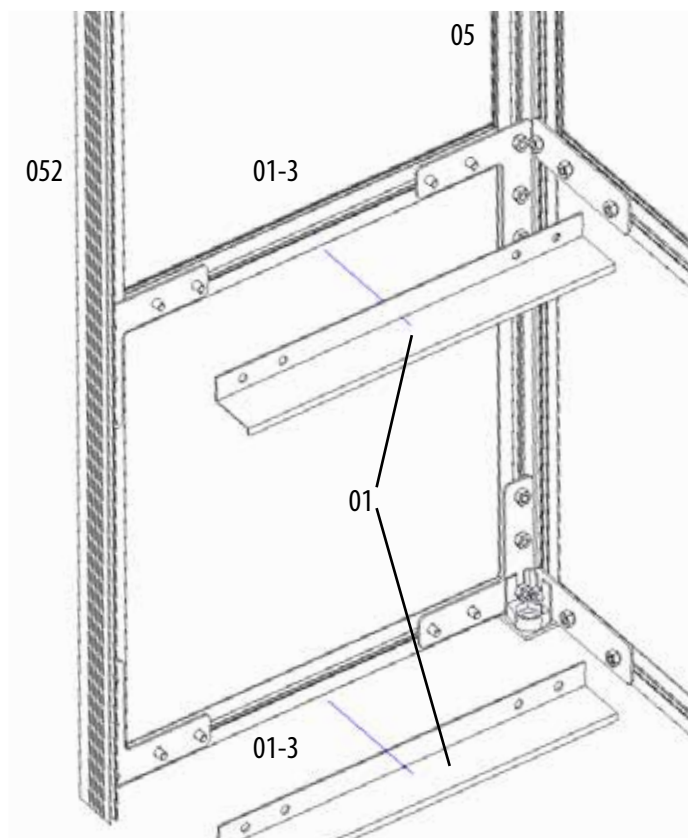

# 27

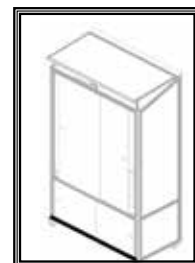
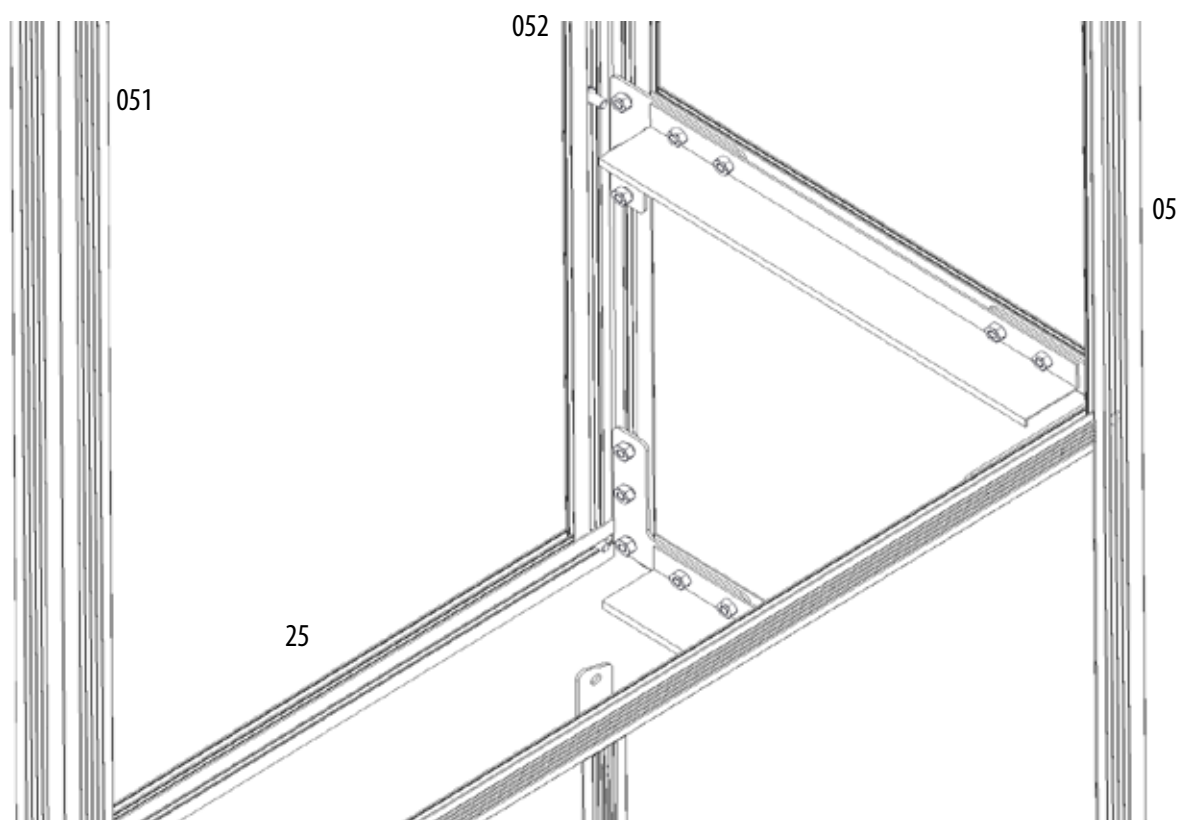

# 28

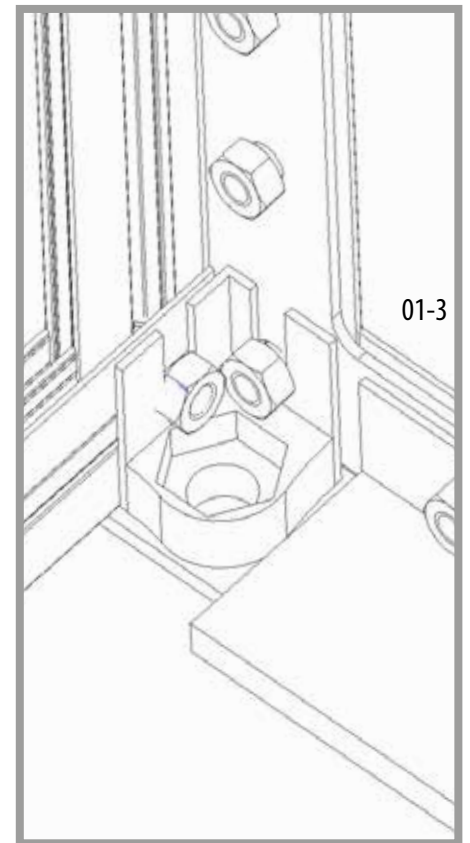
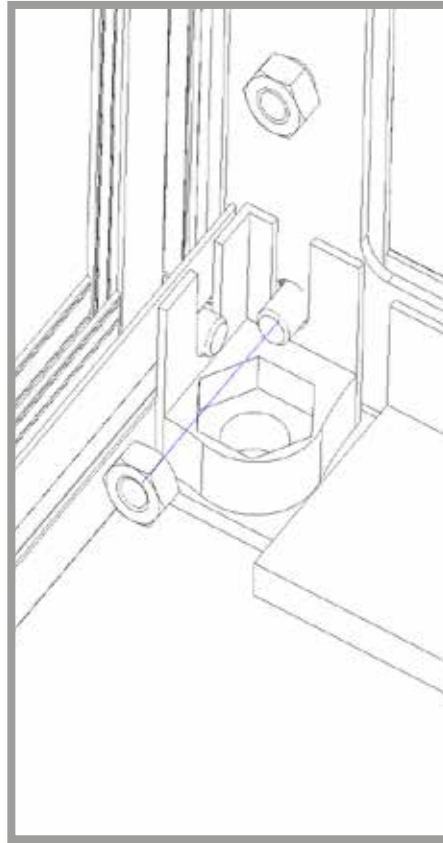
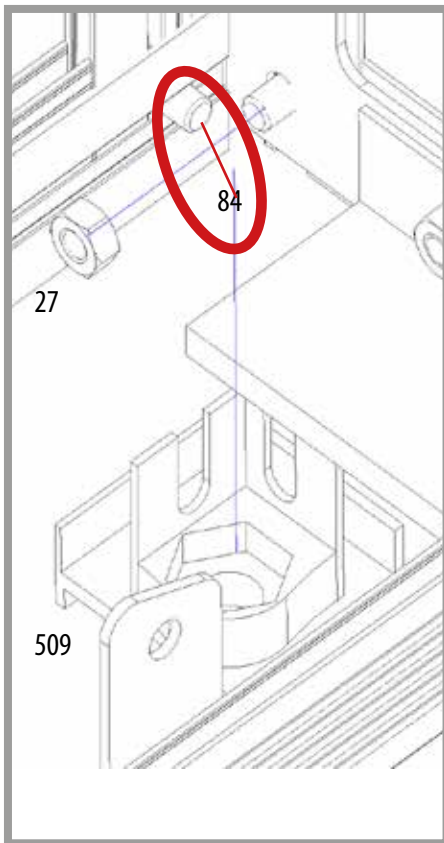

# 29

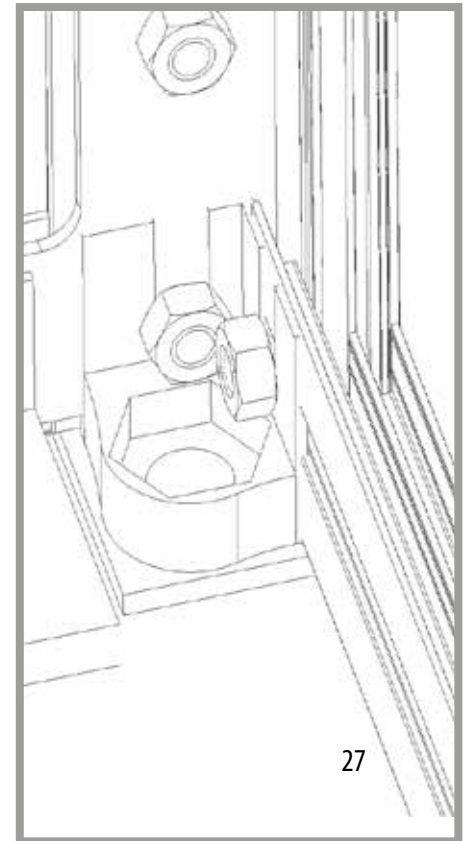
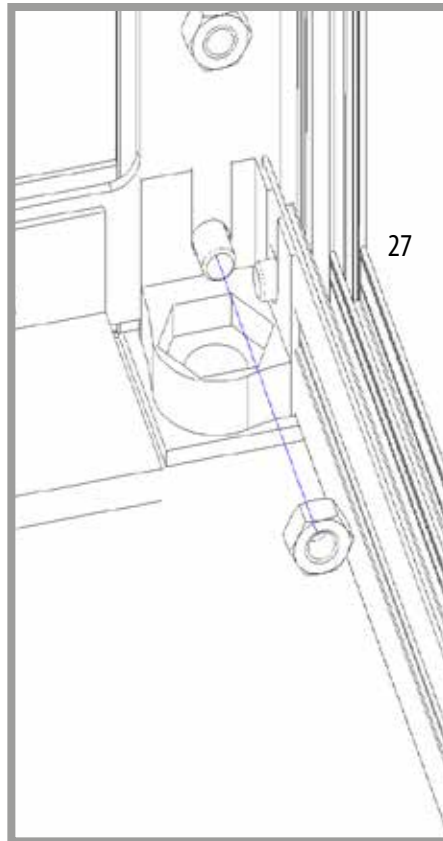
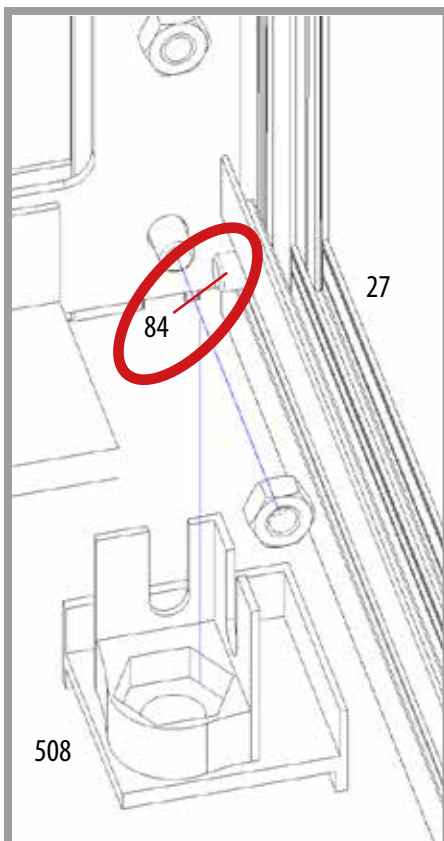

# 30

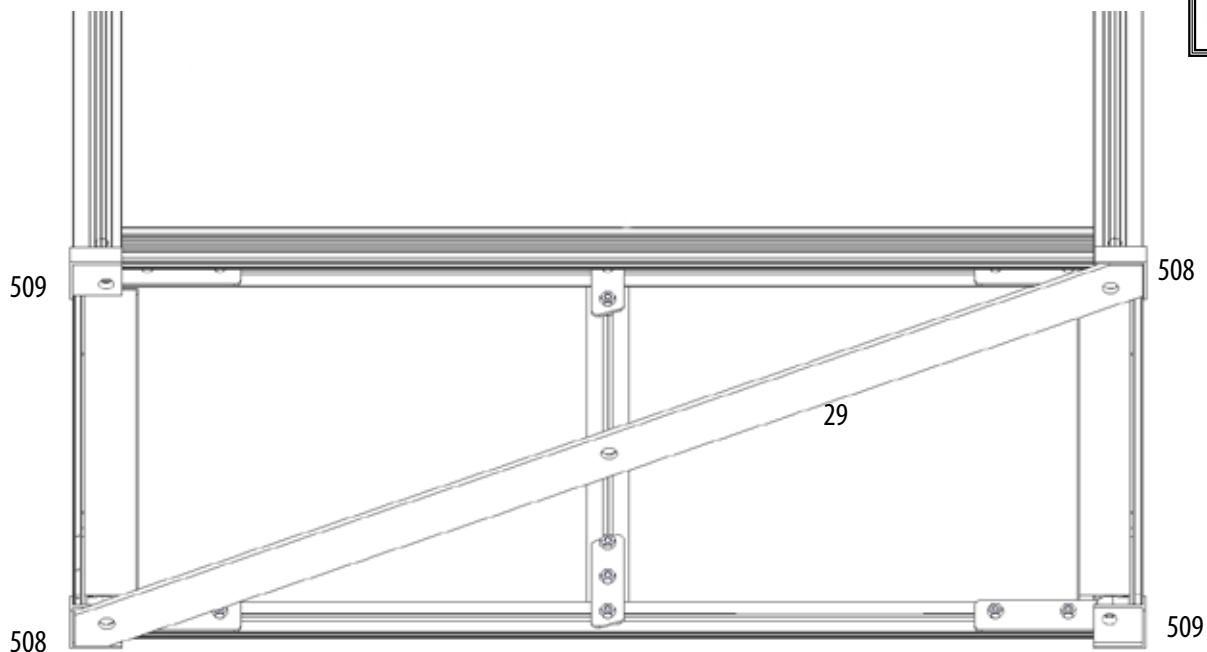
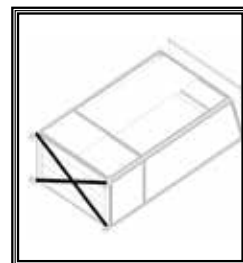

# 31

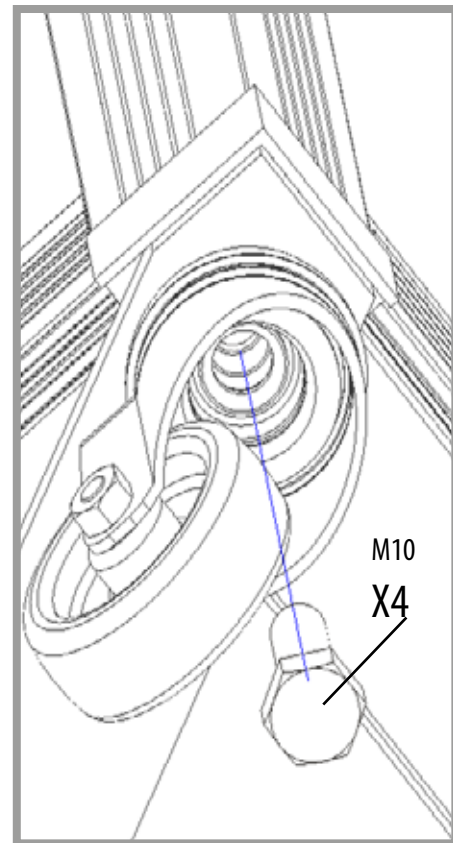
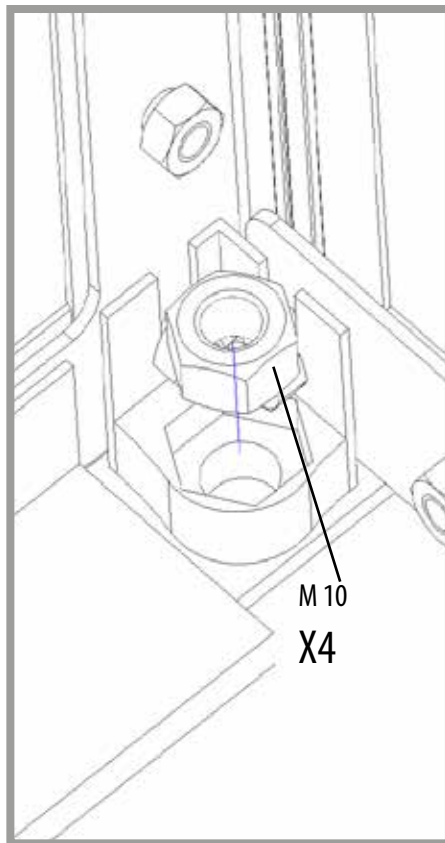
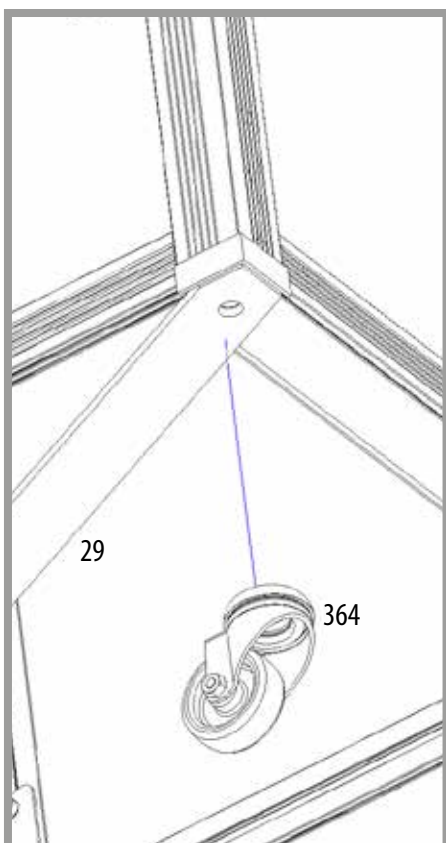

# 32

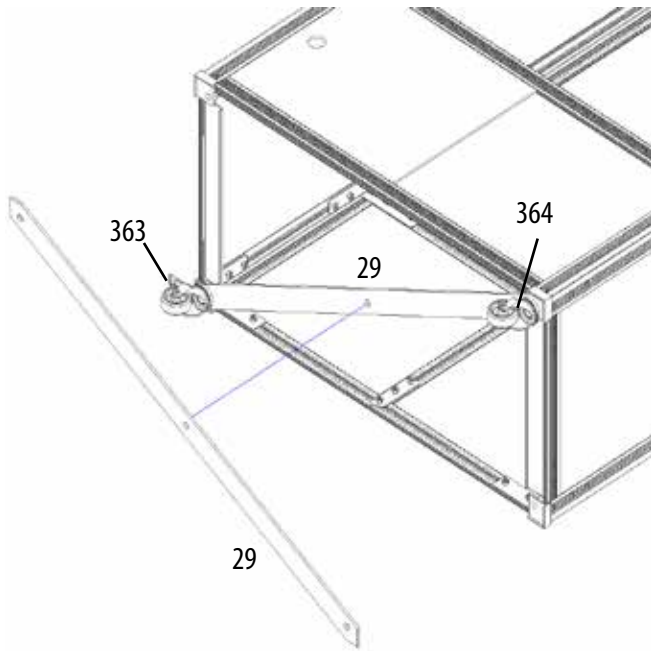

# 33

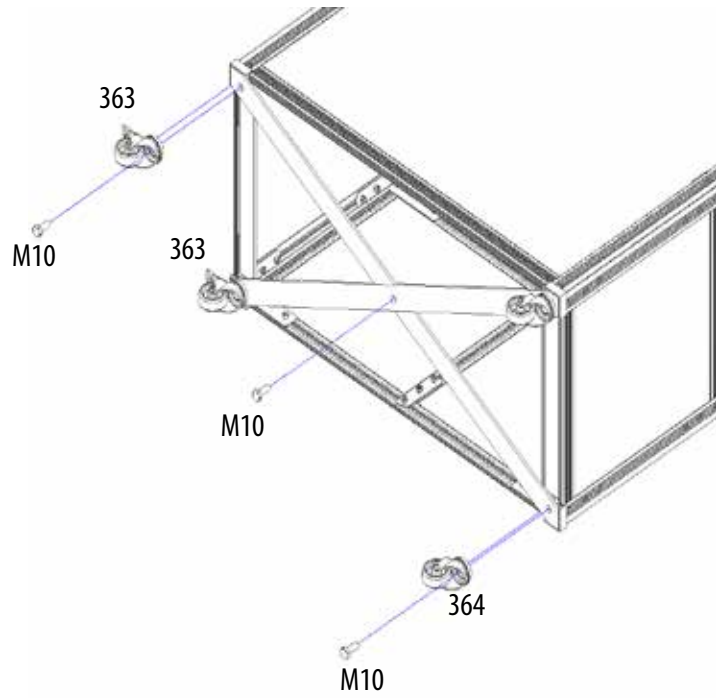

# 34

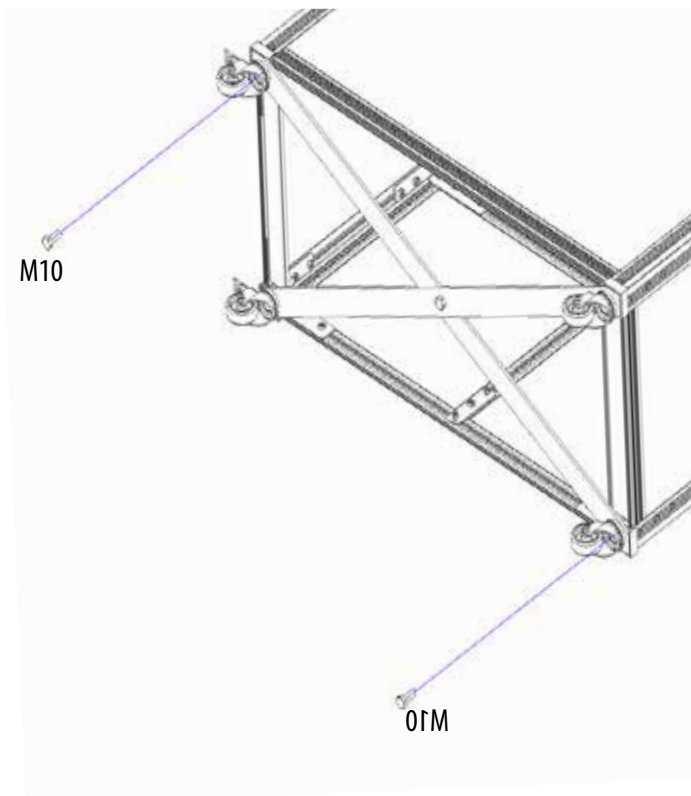

# 35

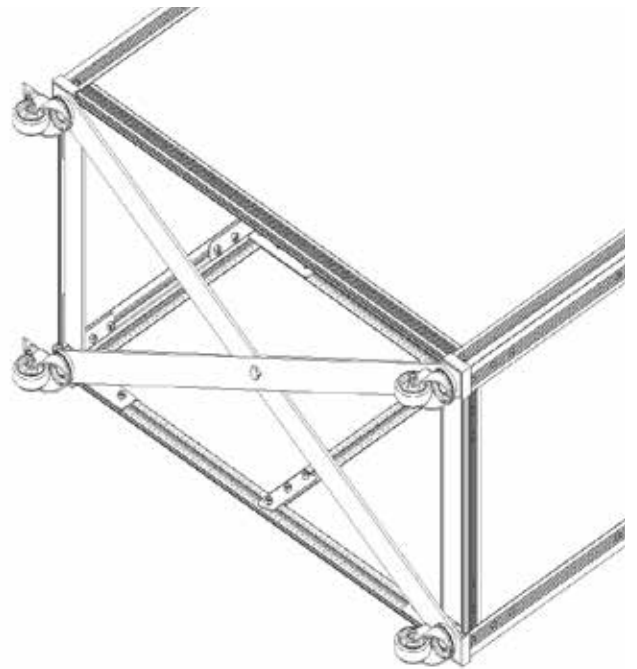

# 36

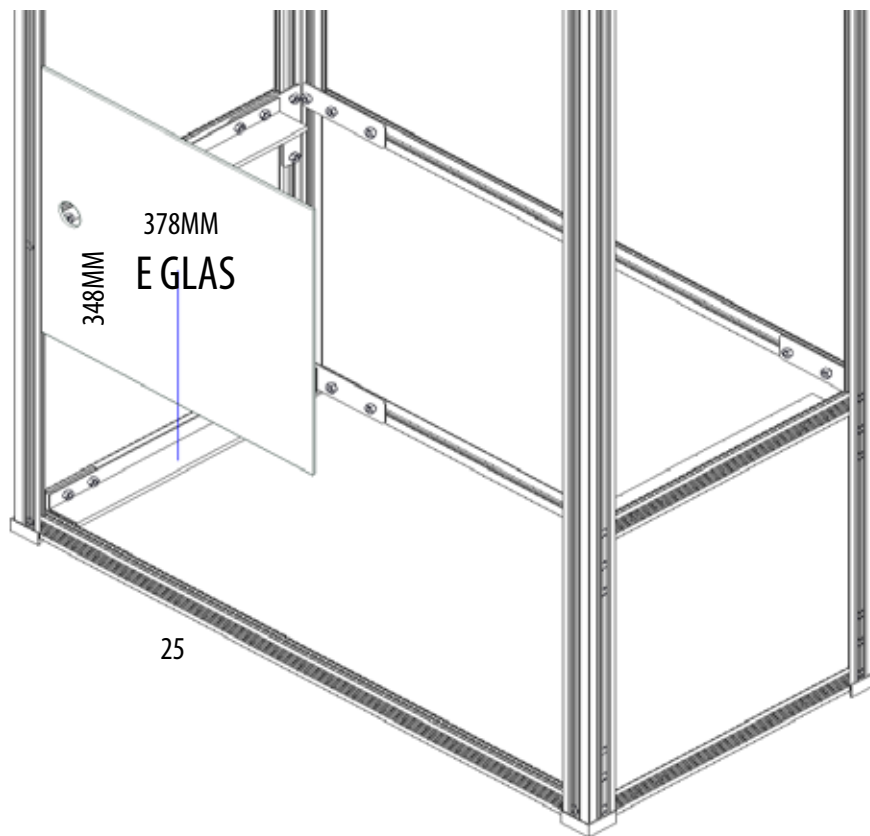

# 37

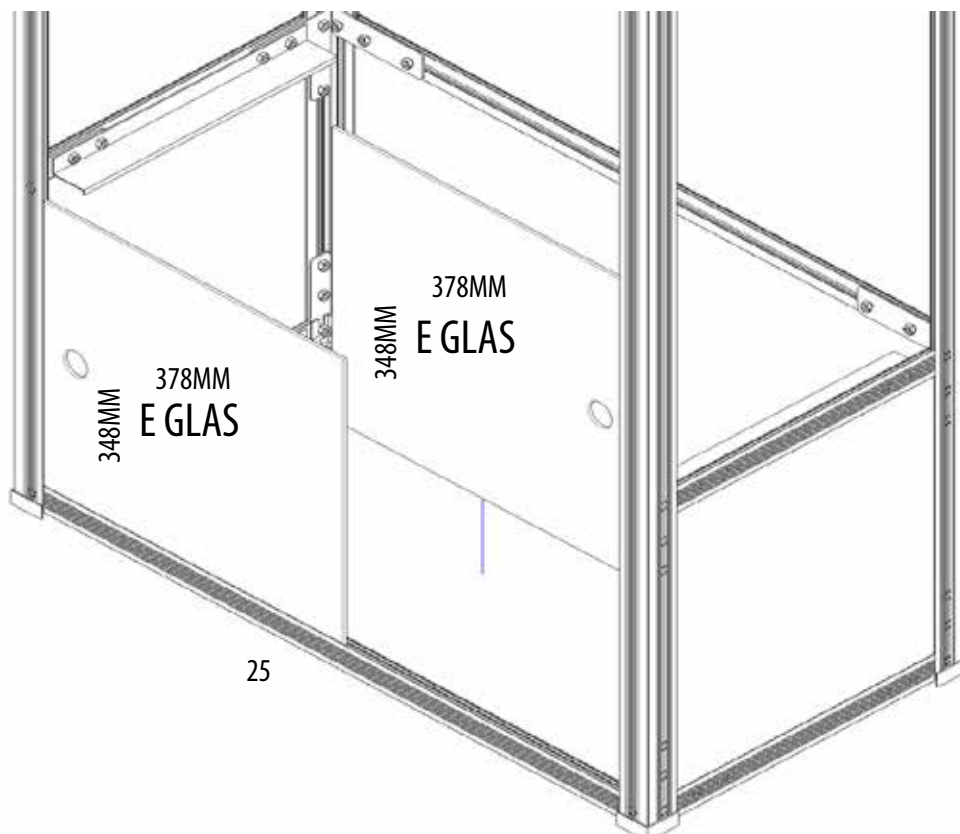

# 38

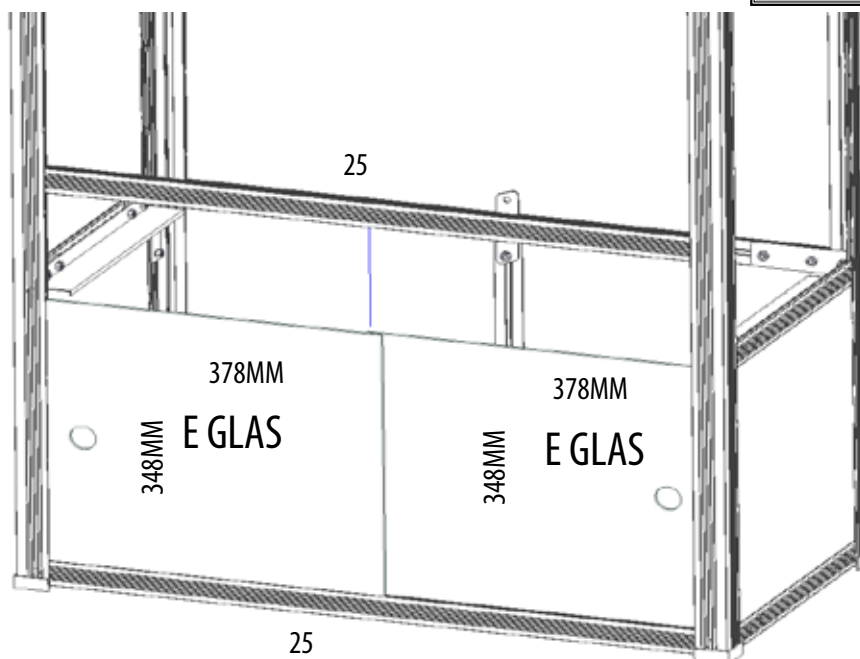
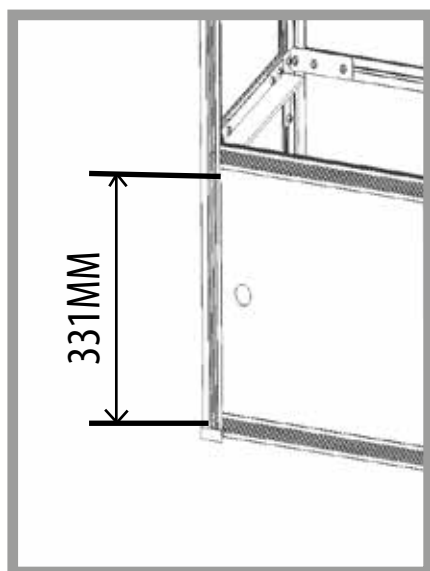
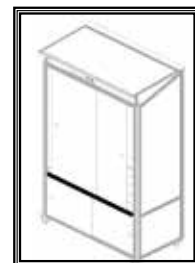

# 39

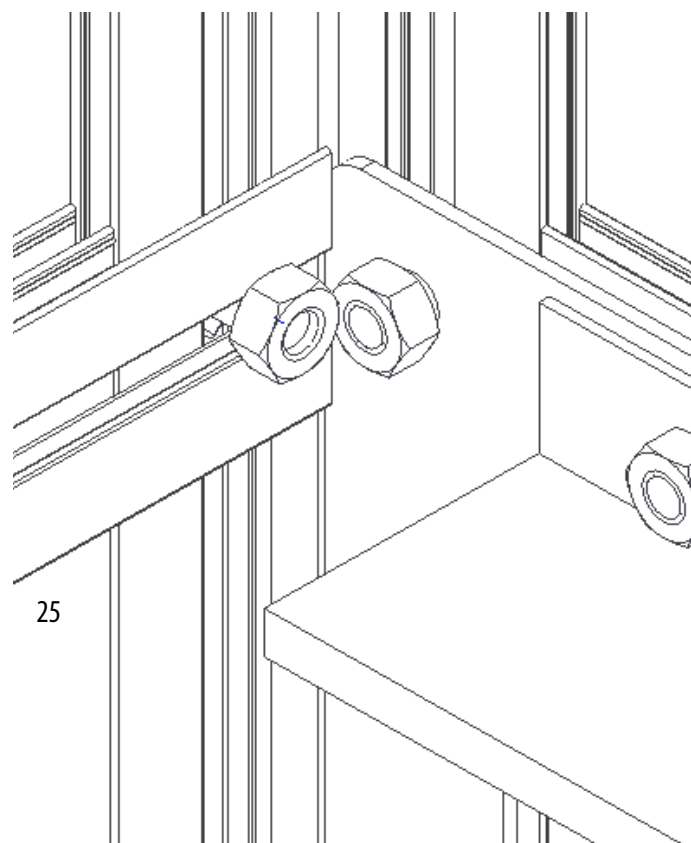
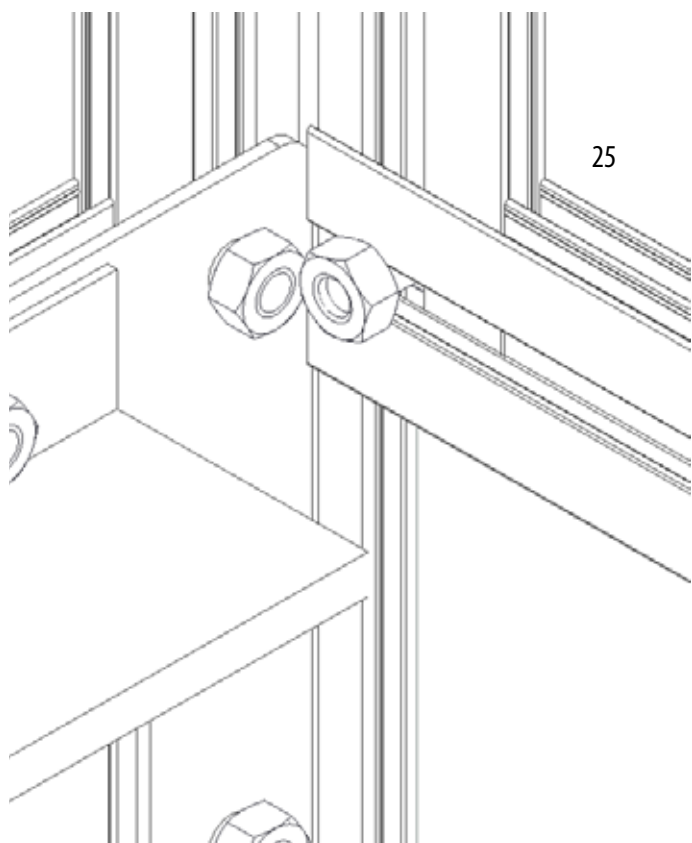



# 40

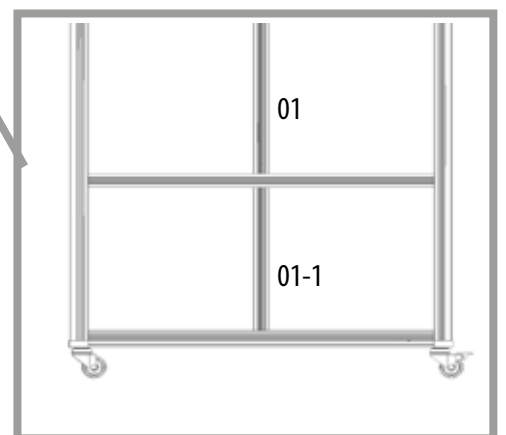
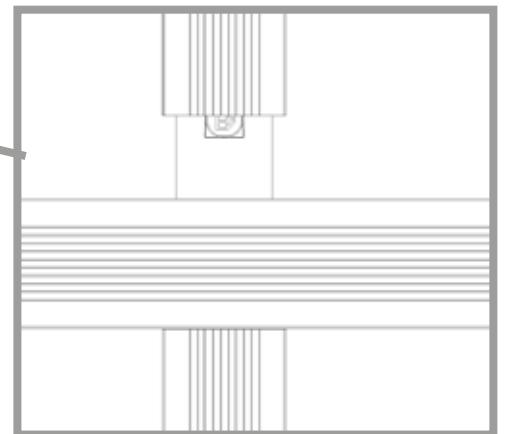
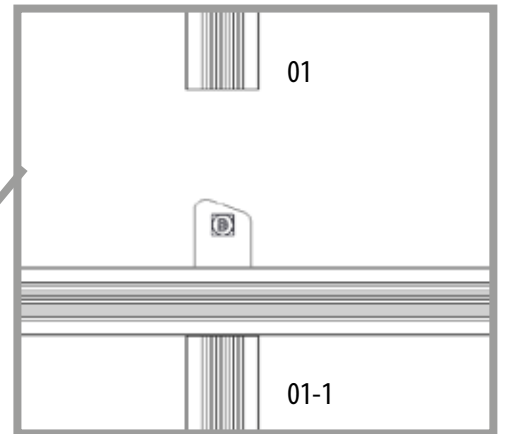
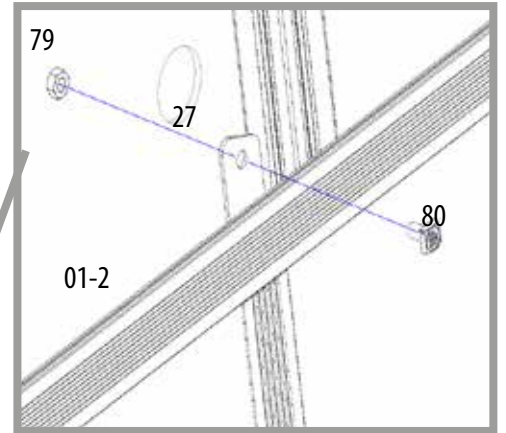
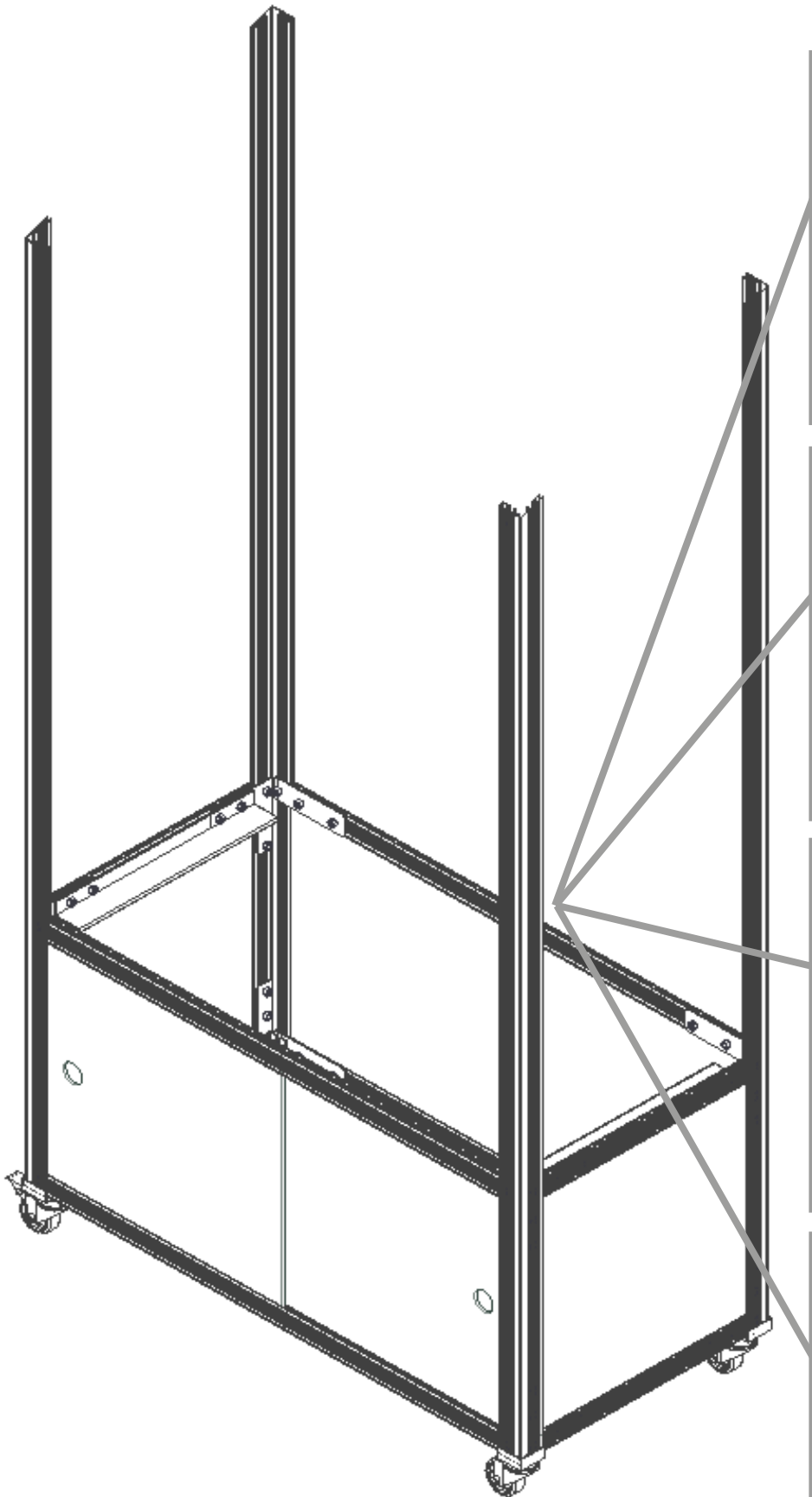
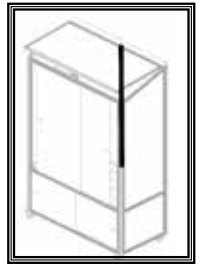

# 41

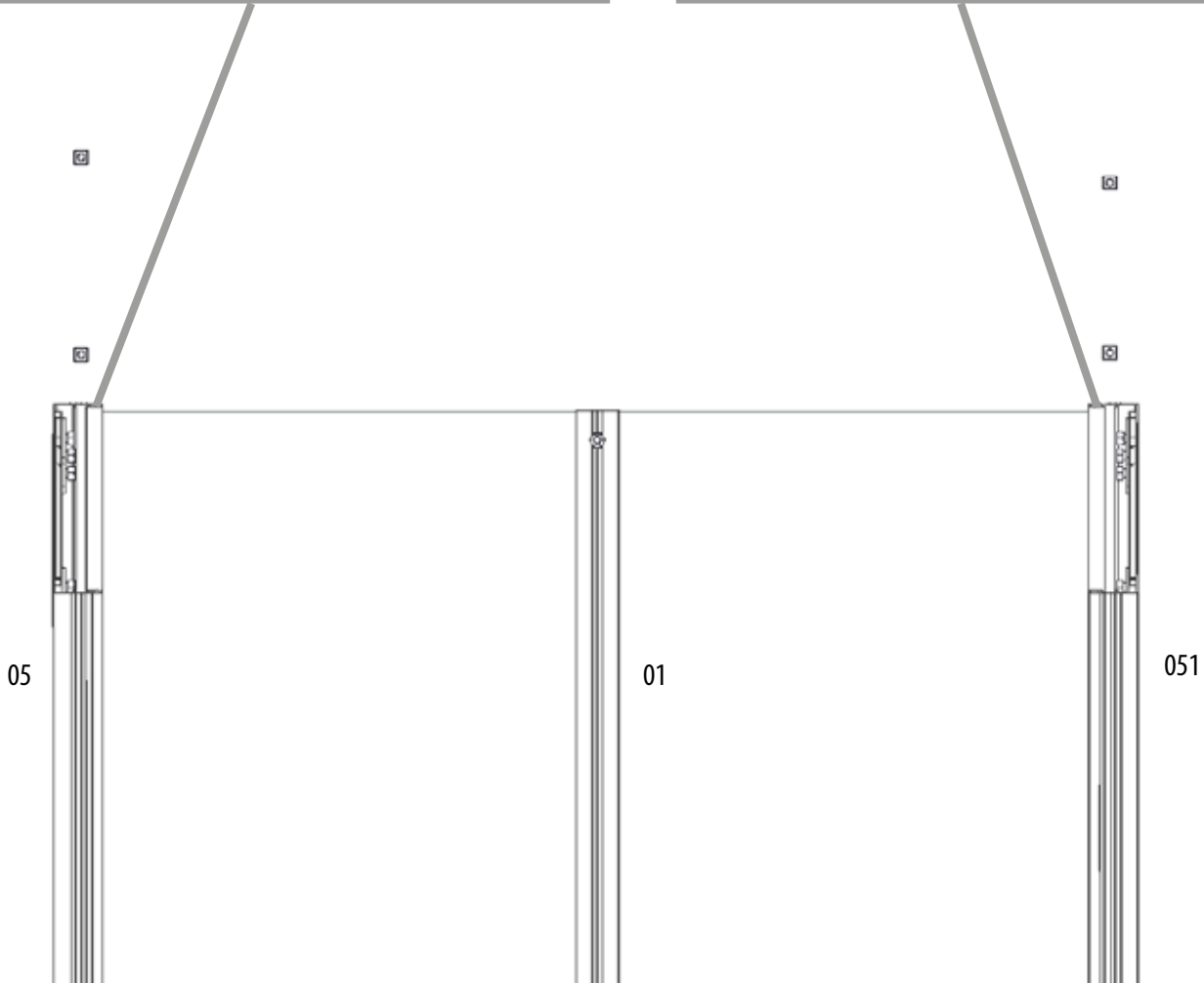
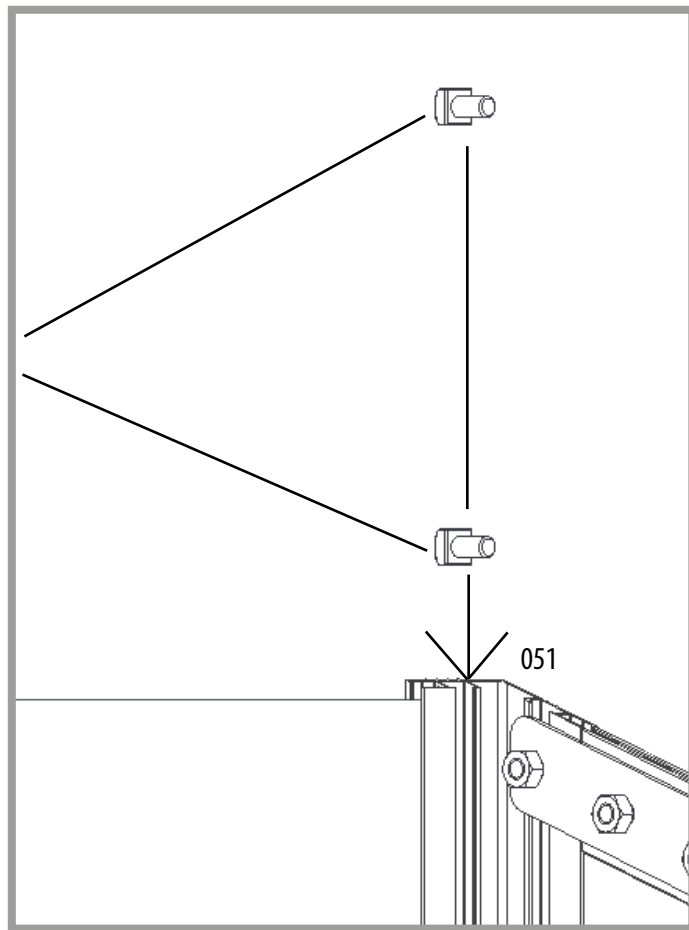
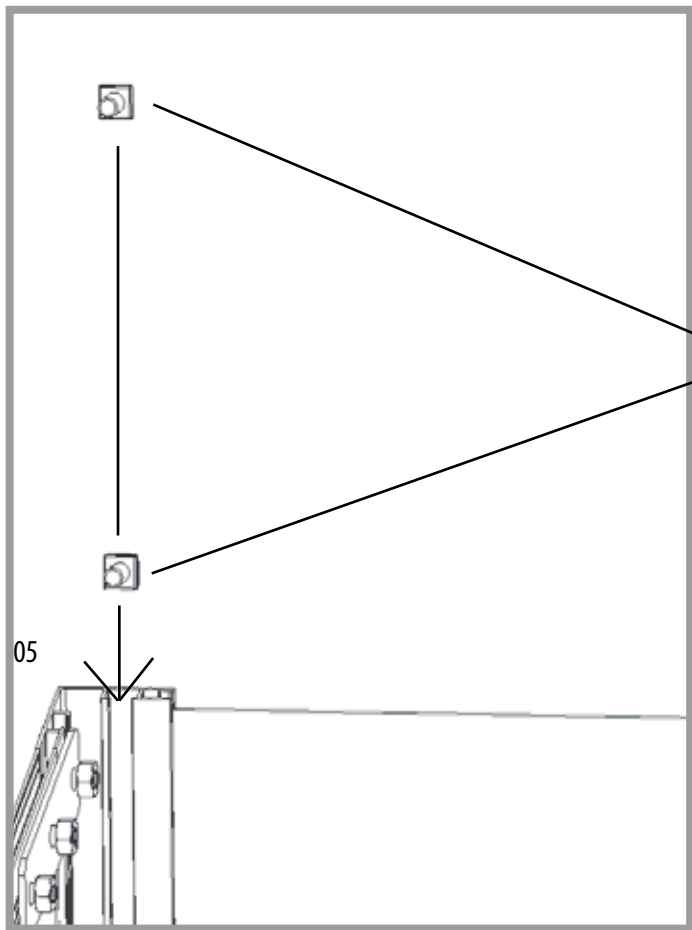

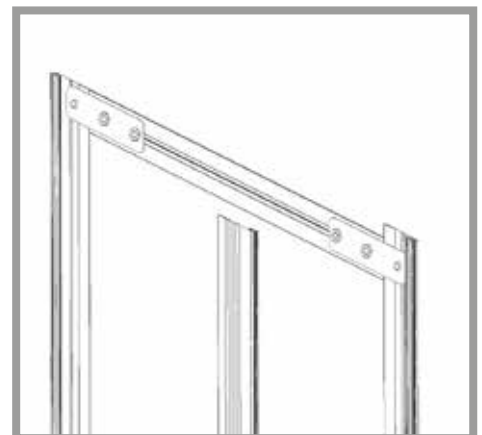
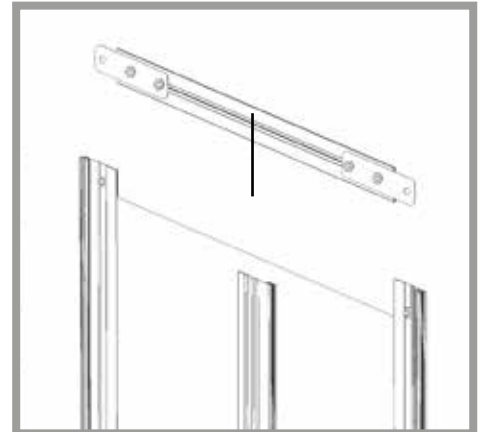
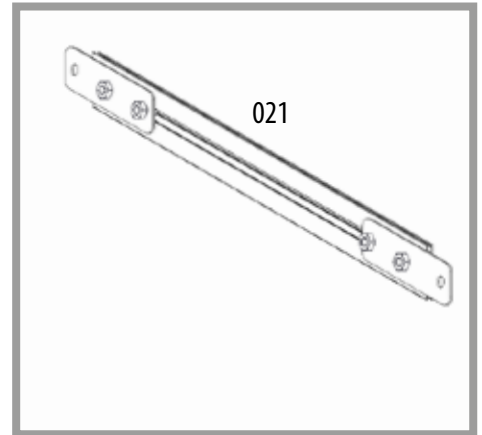
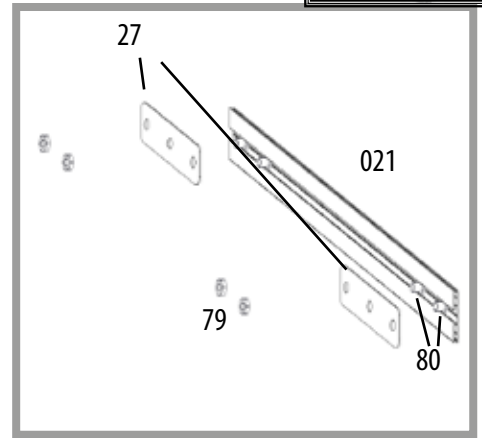
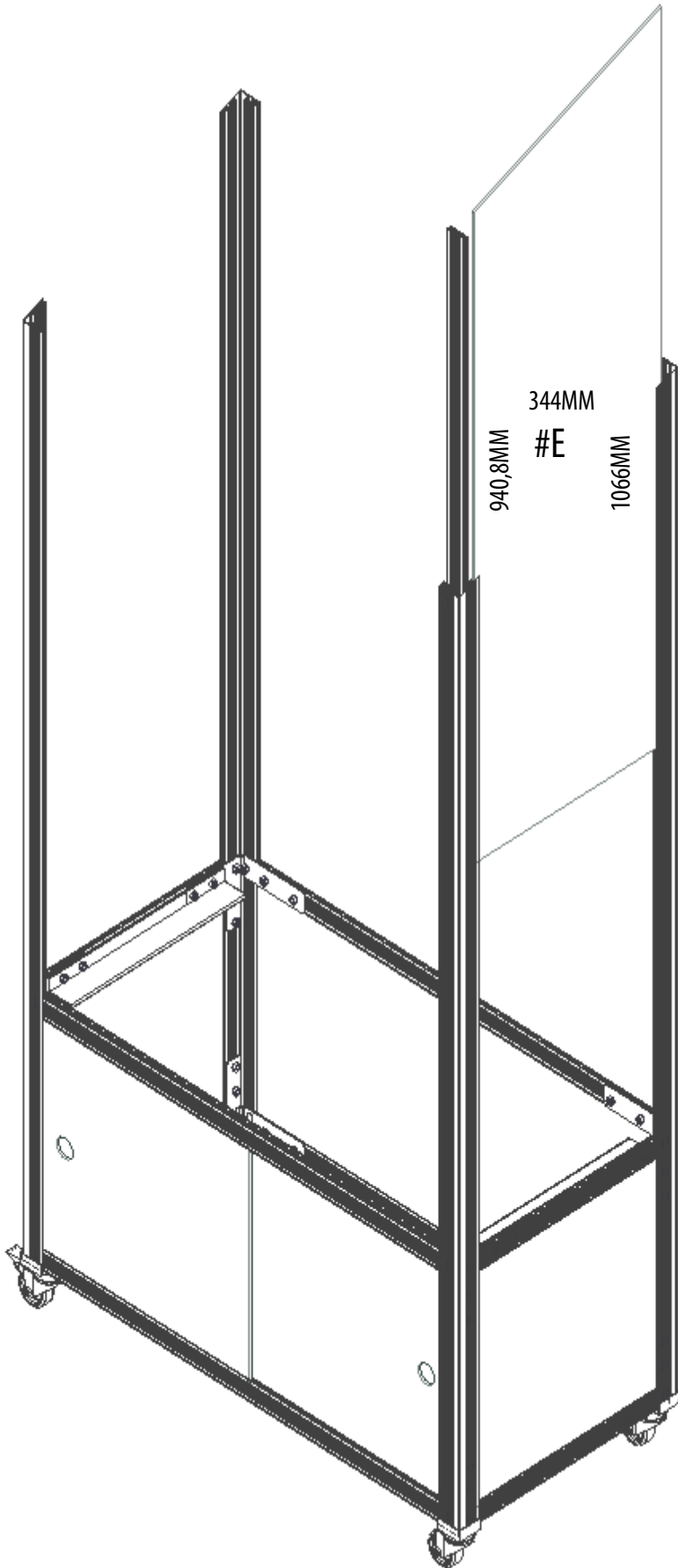
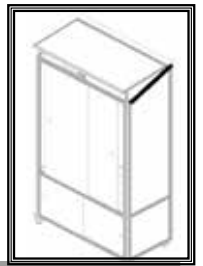

# 43

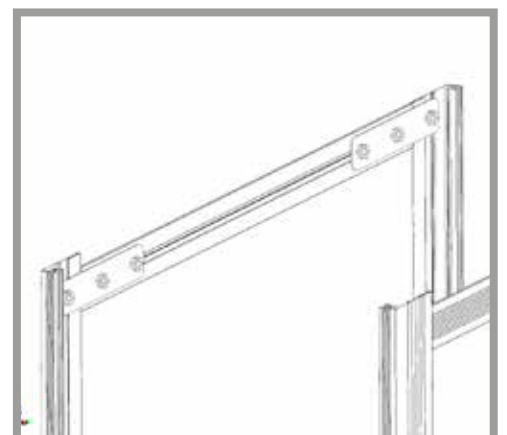
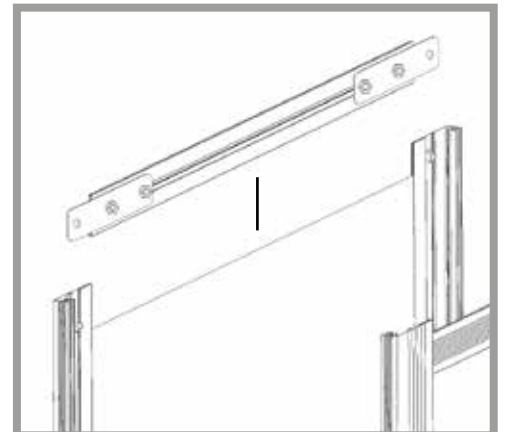
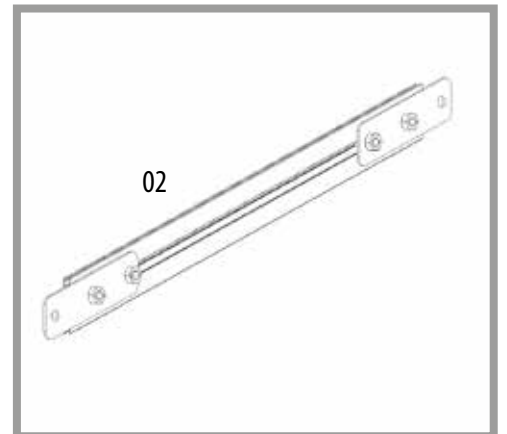
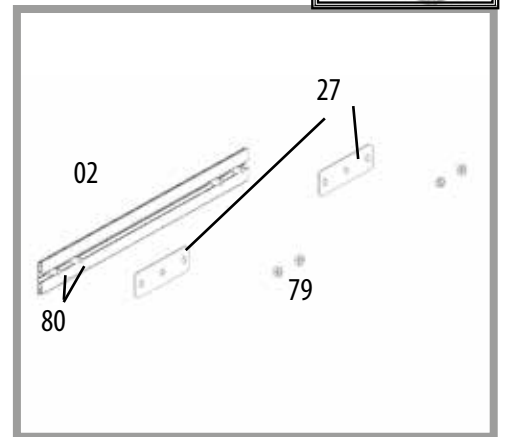
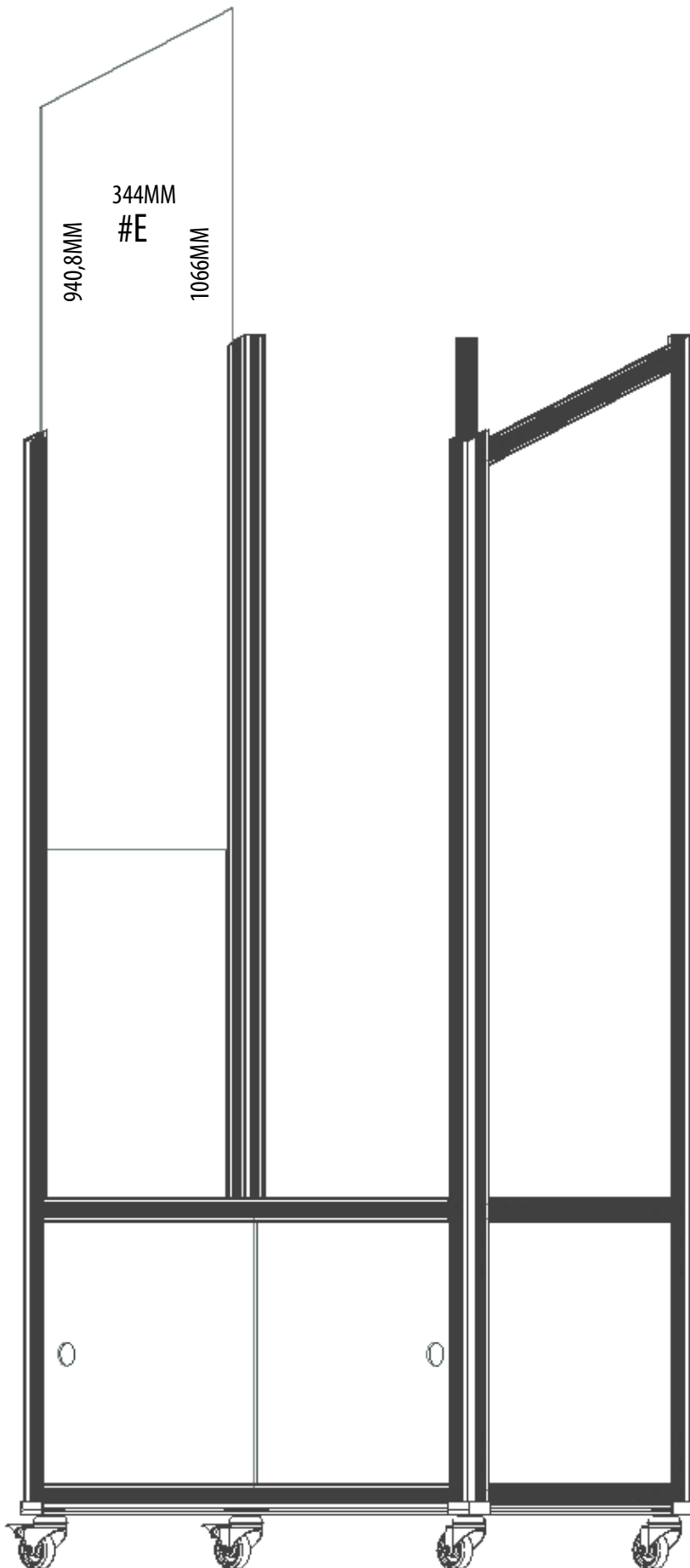
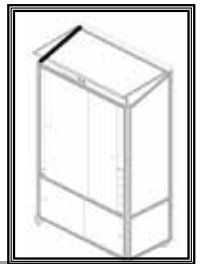

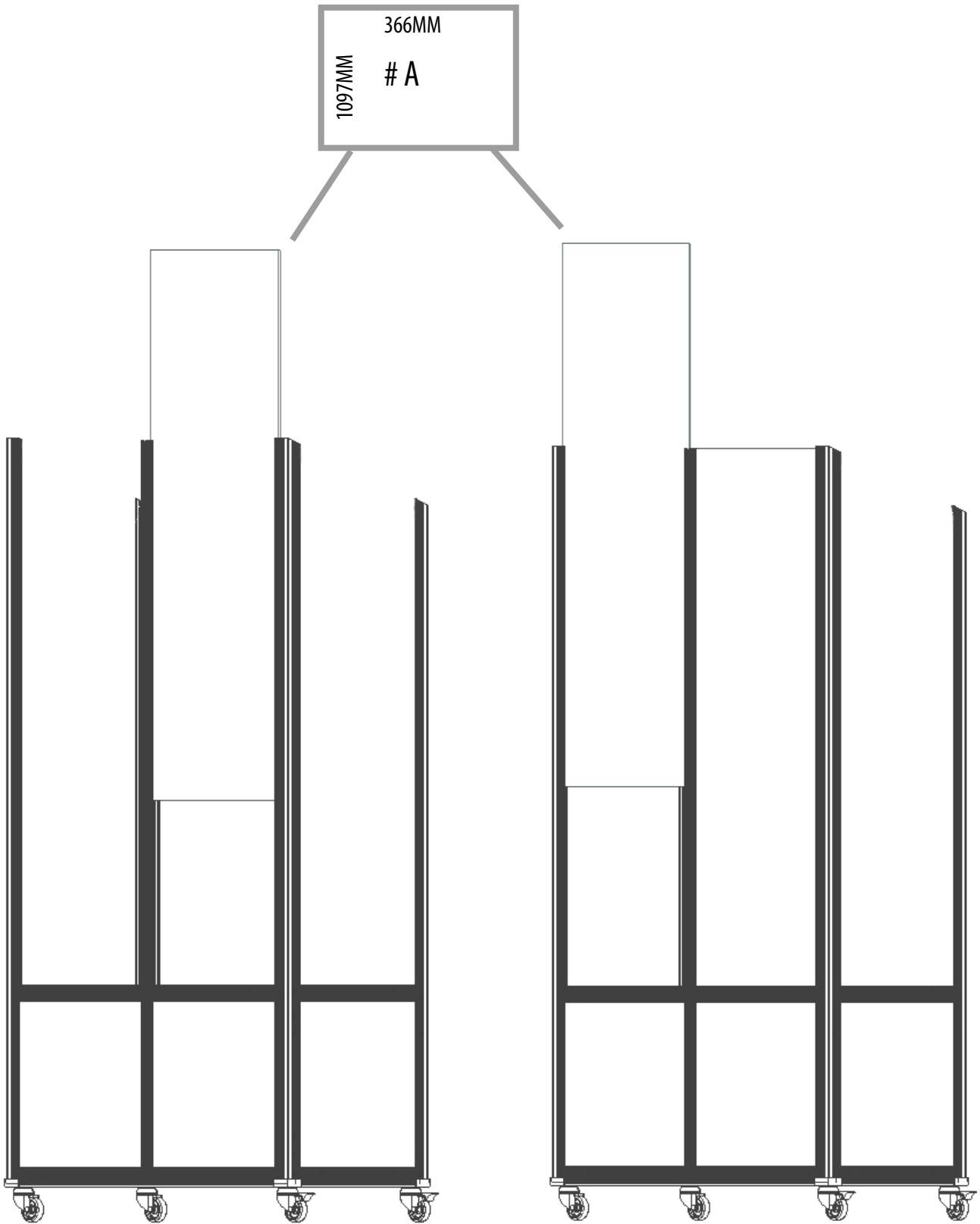

# 45

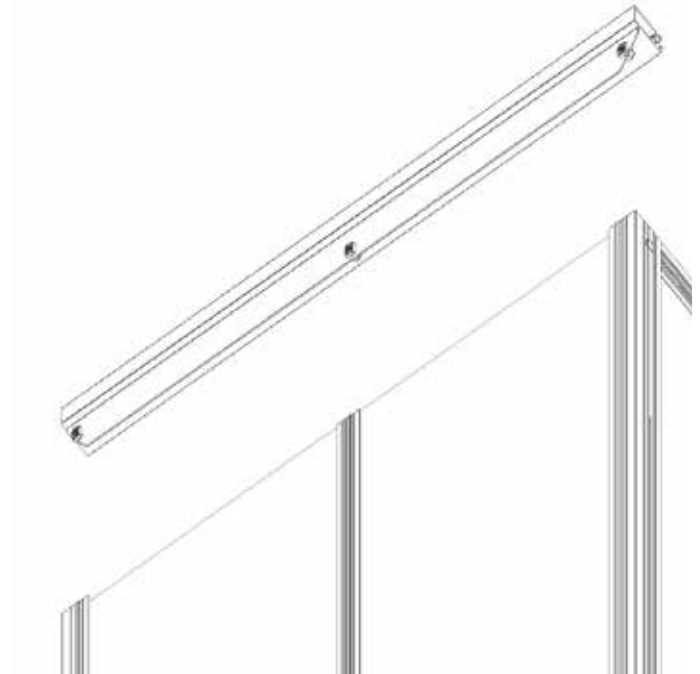
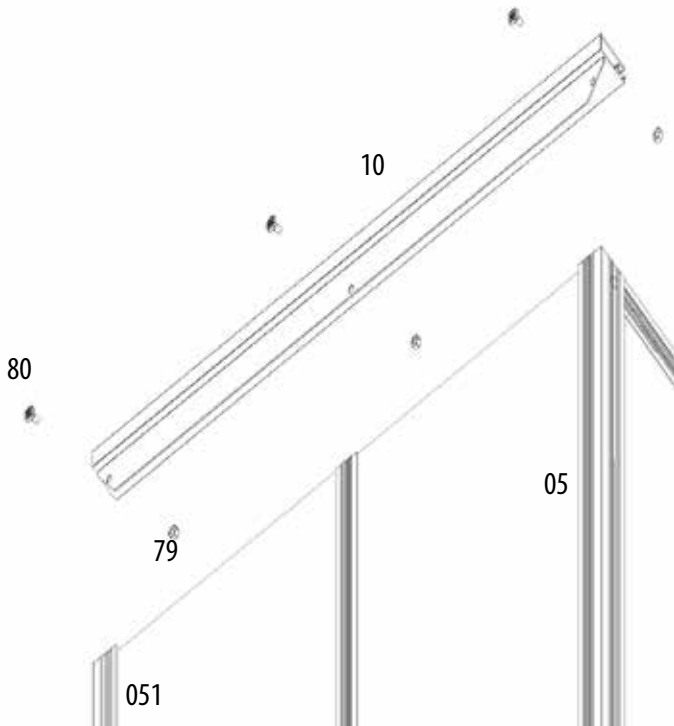
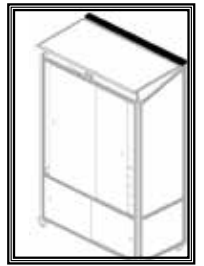

# 46

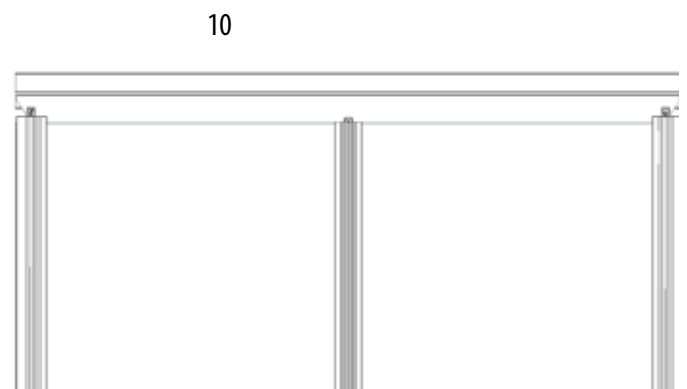
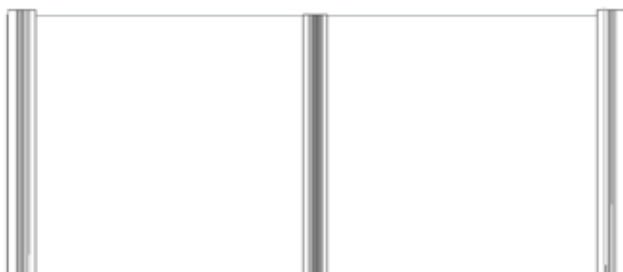

# 47

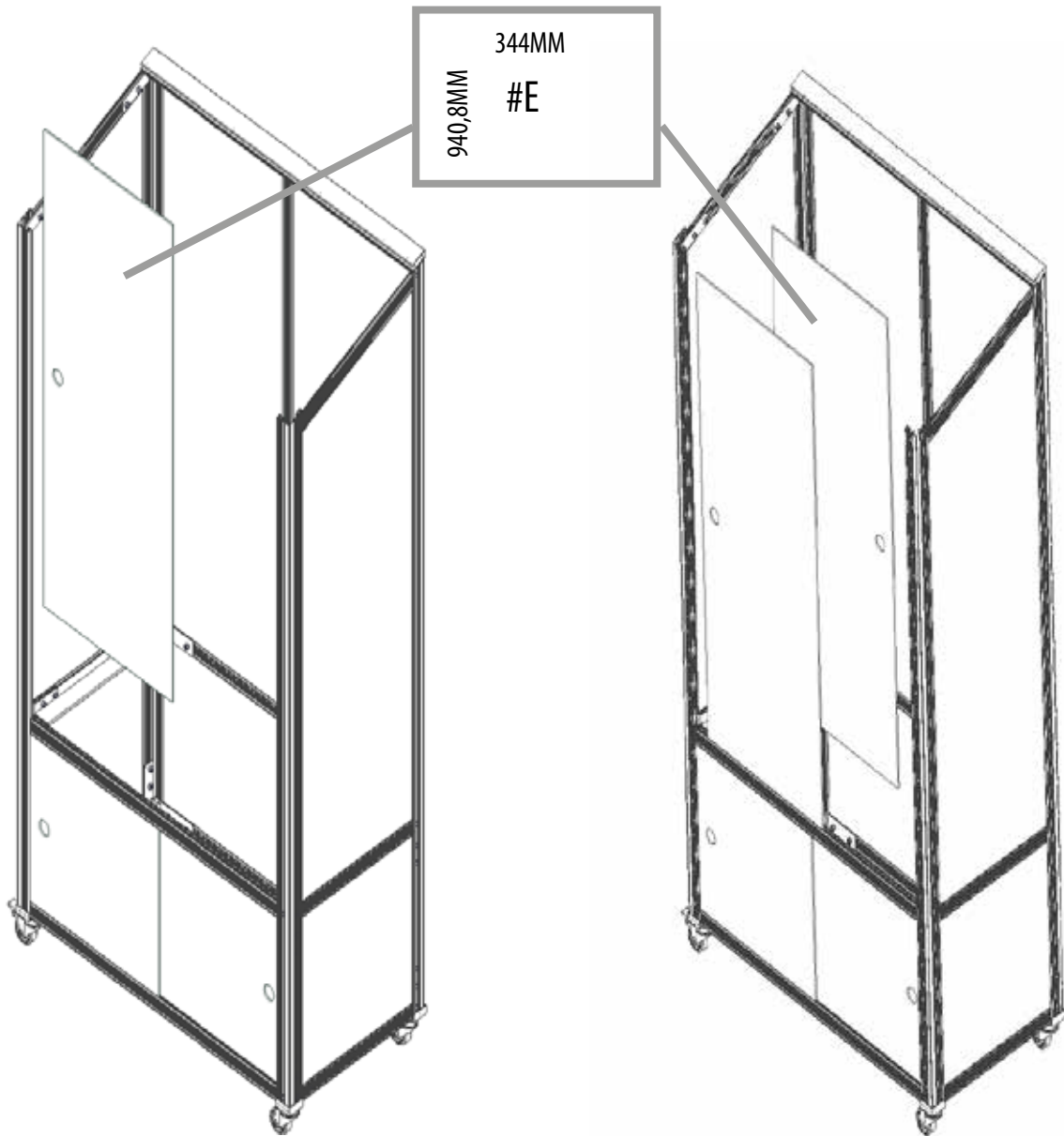

# 48

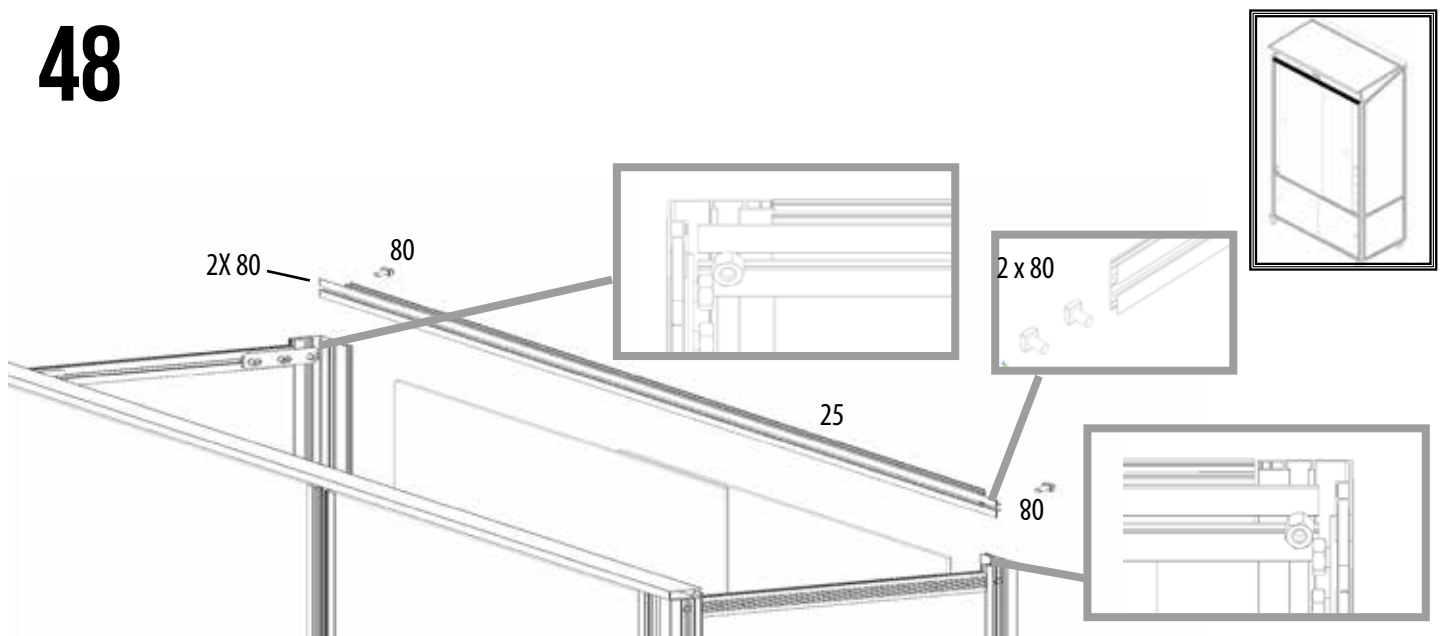

49

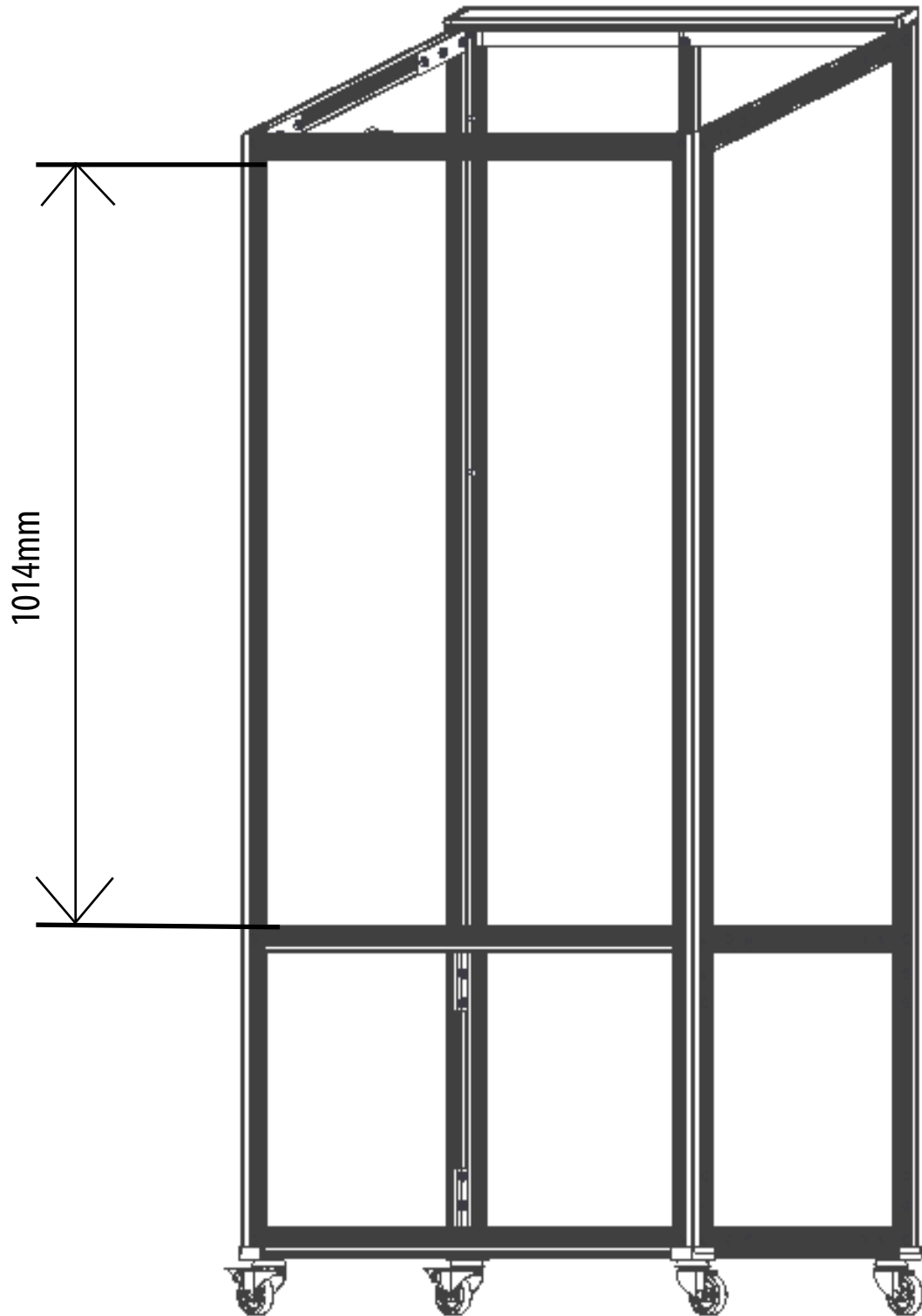



# 50

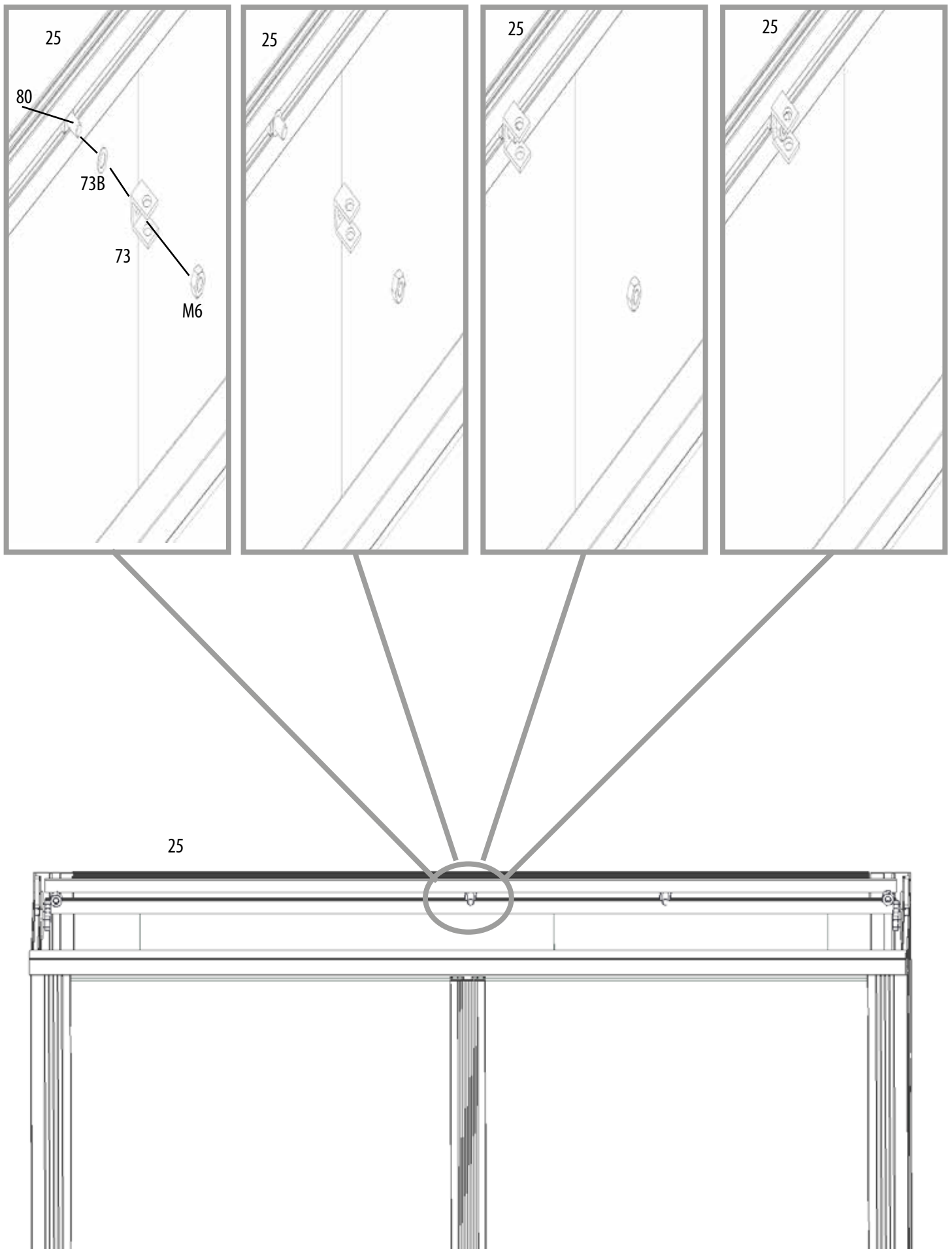

# 51

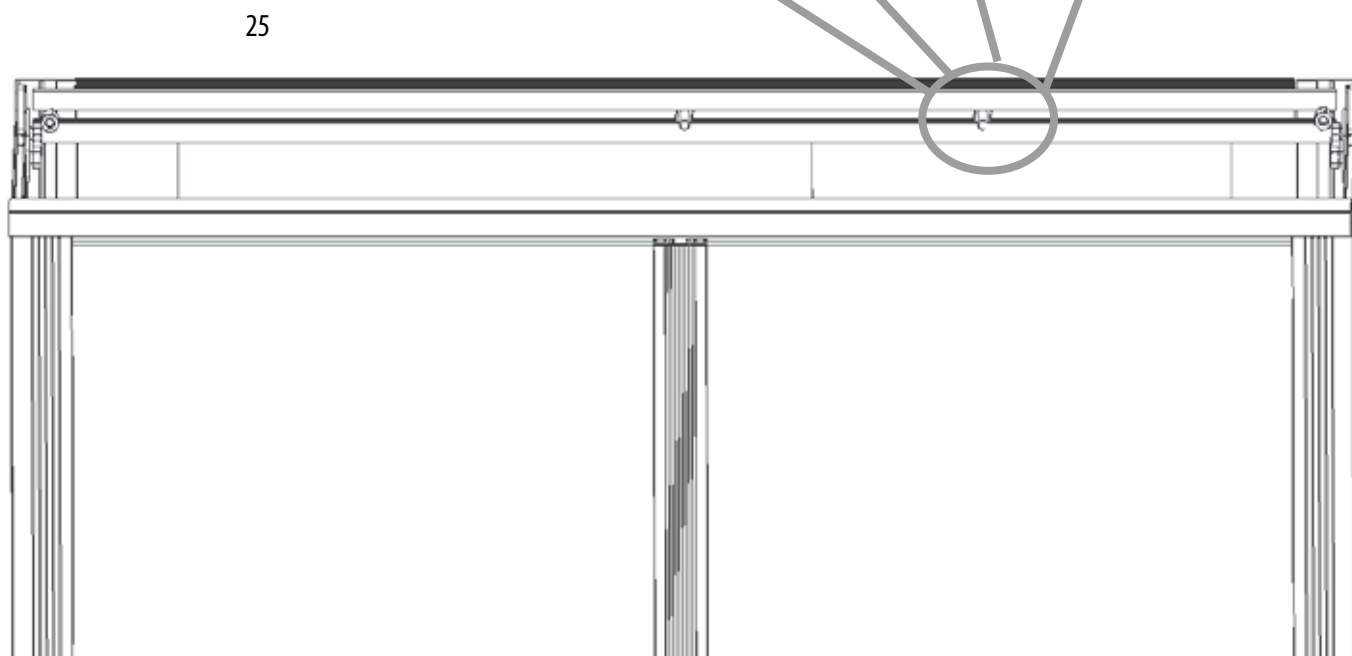
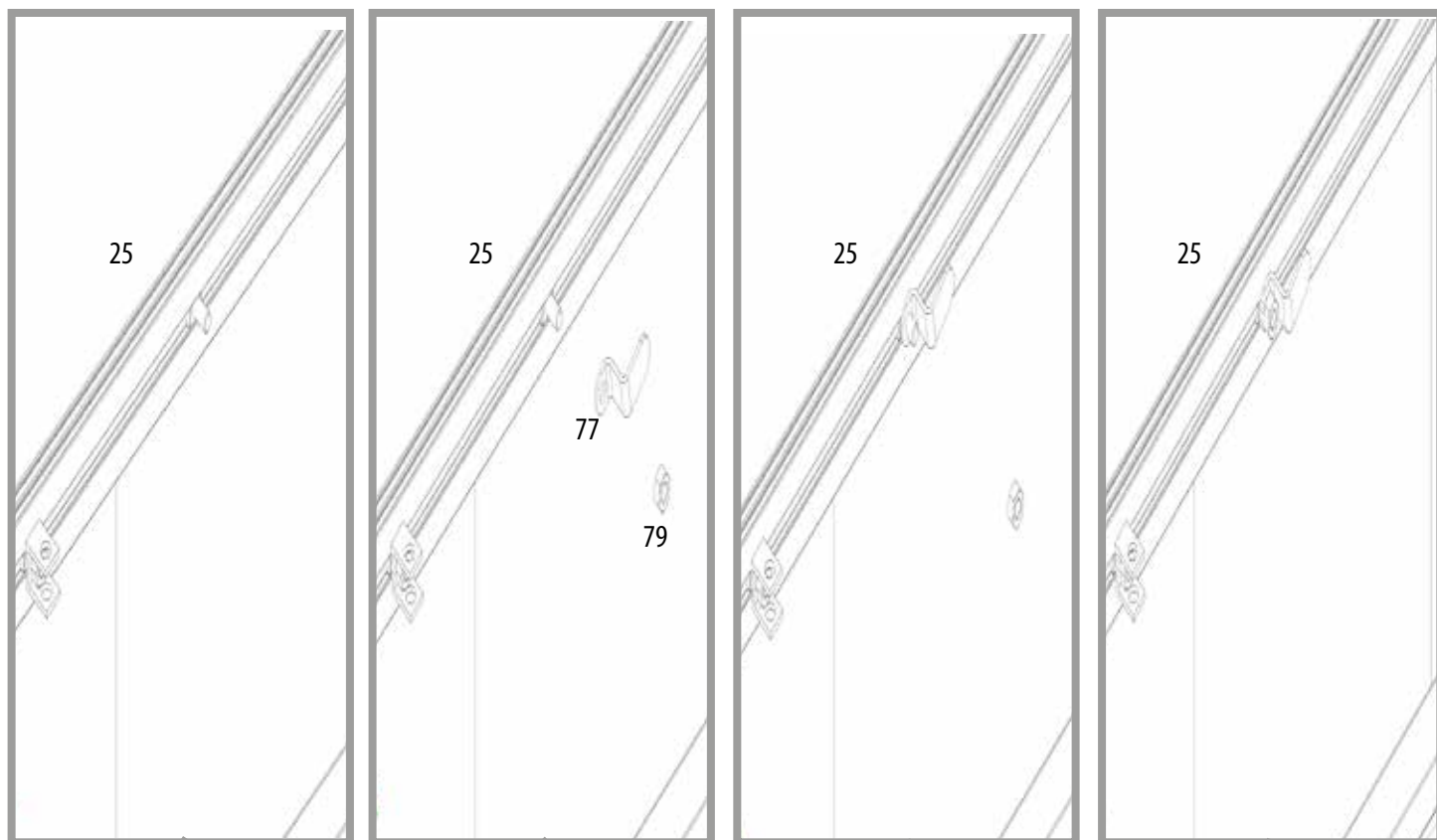

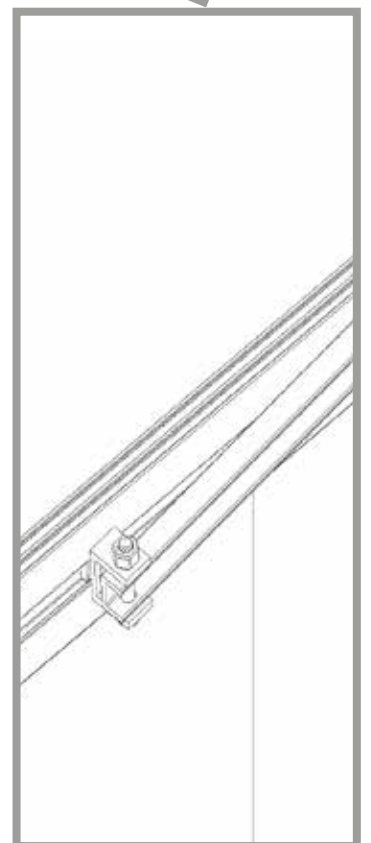
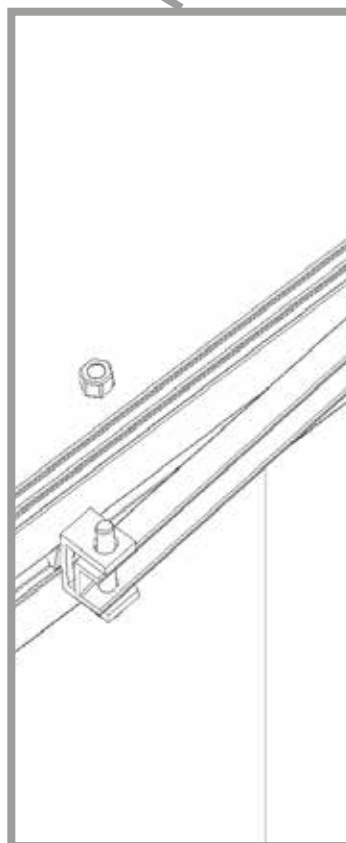
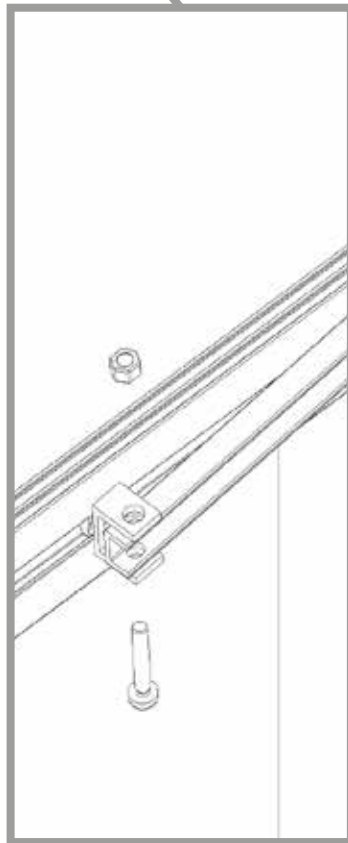
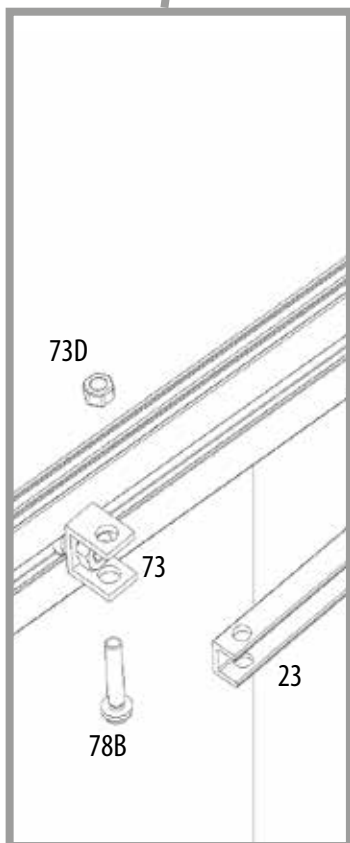
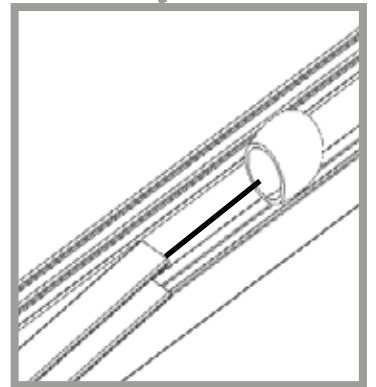
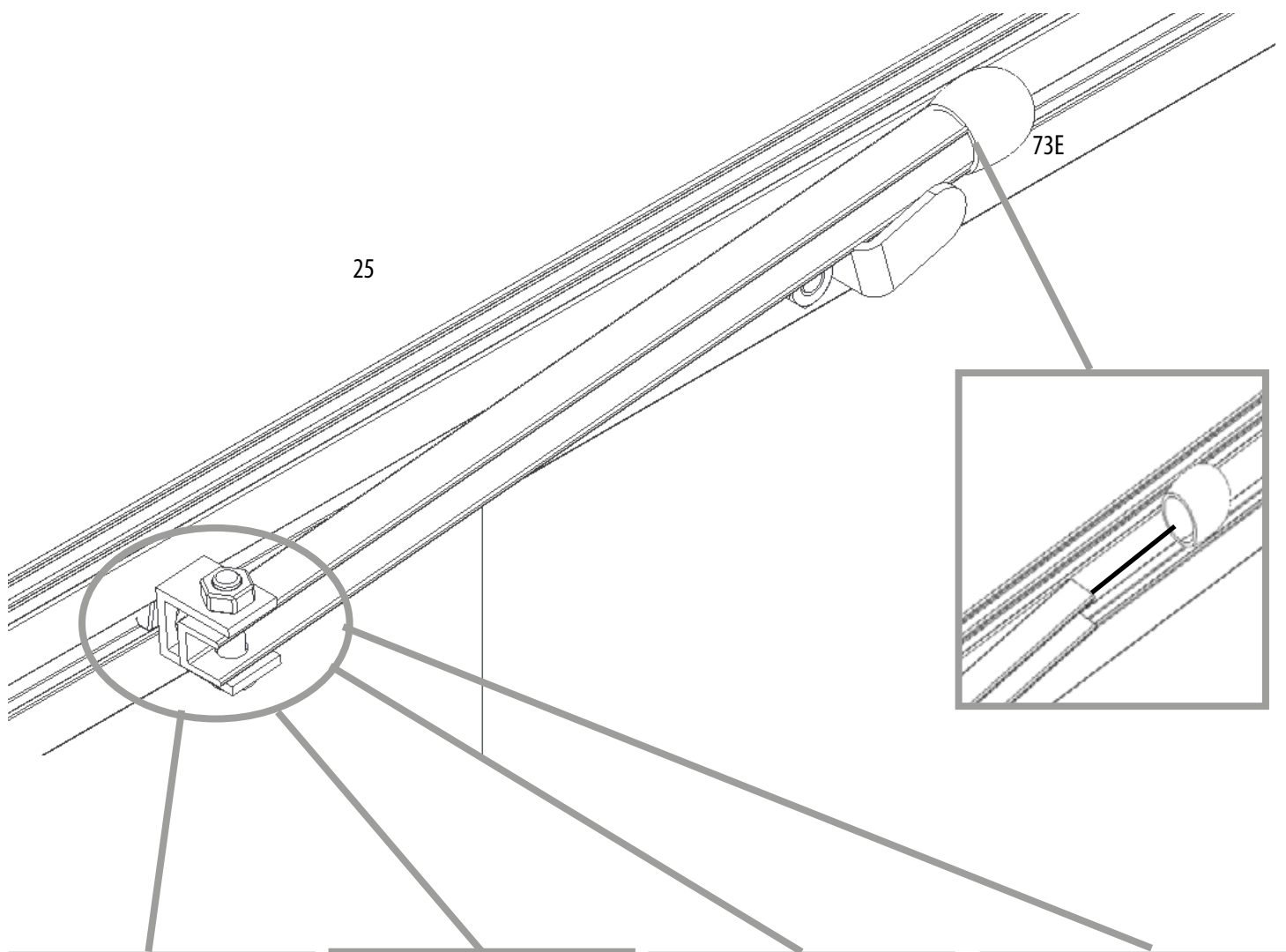

# 53

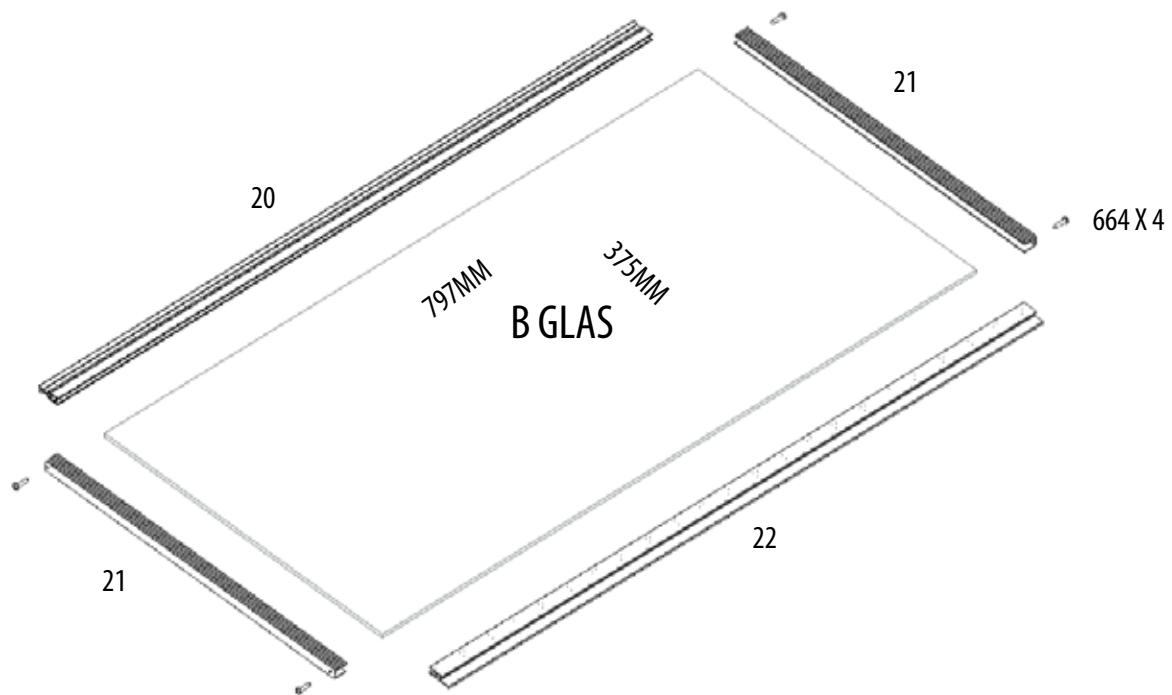
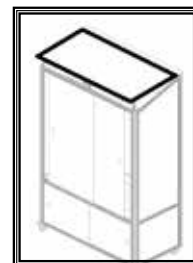

# 54

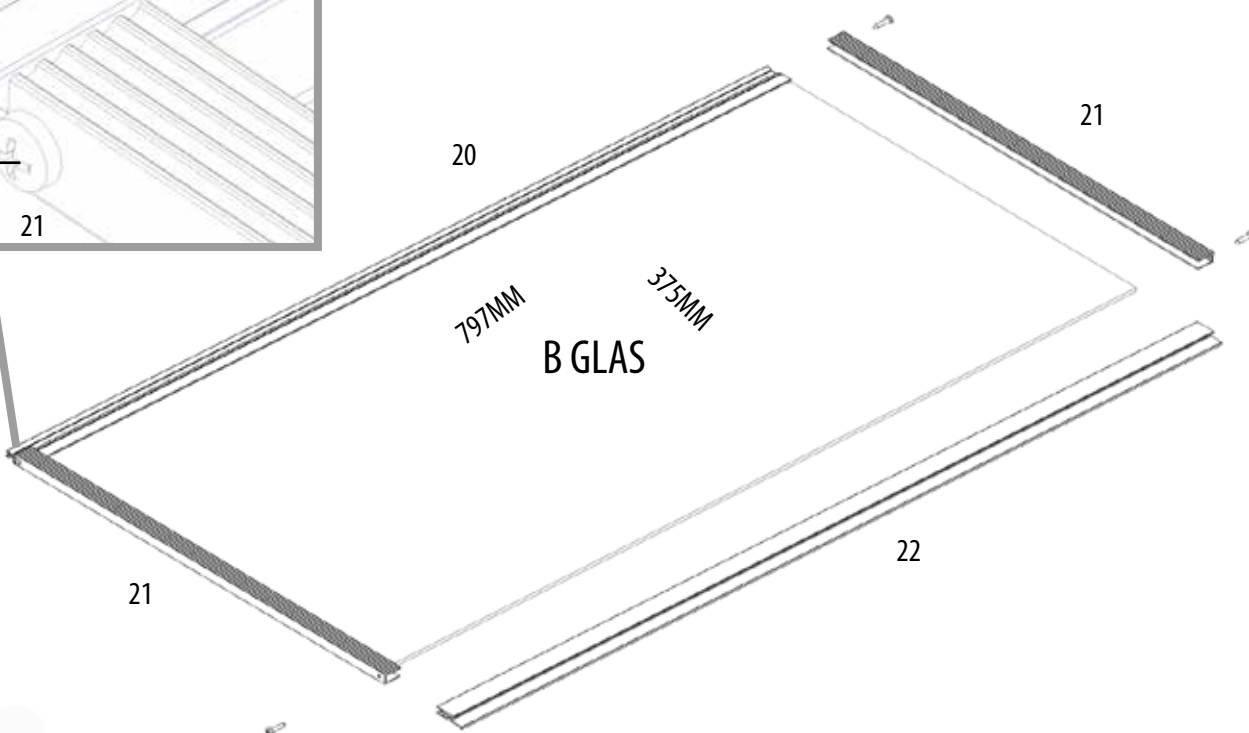
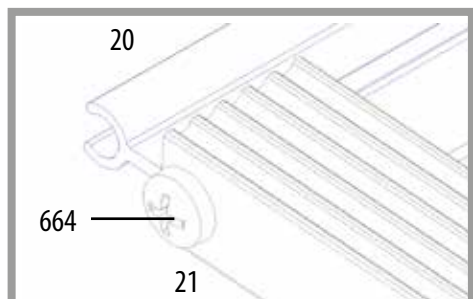

# 55

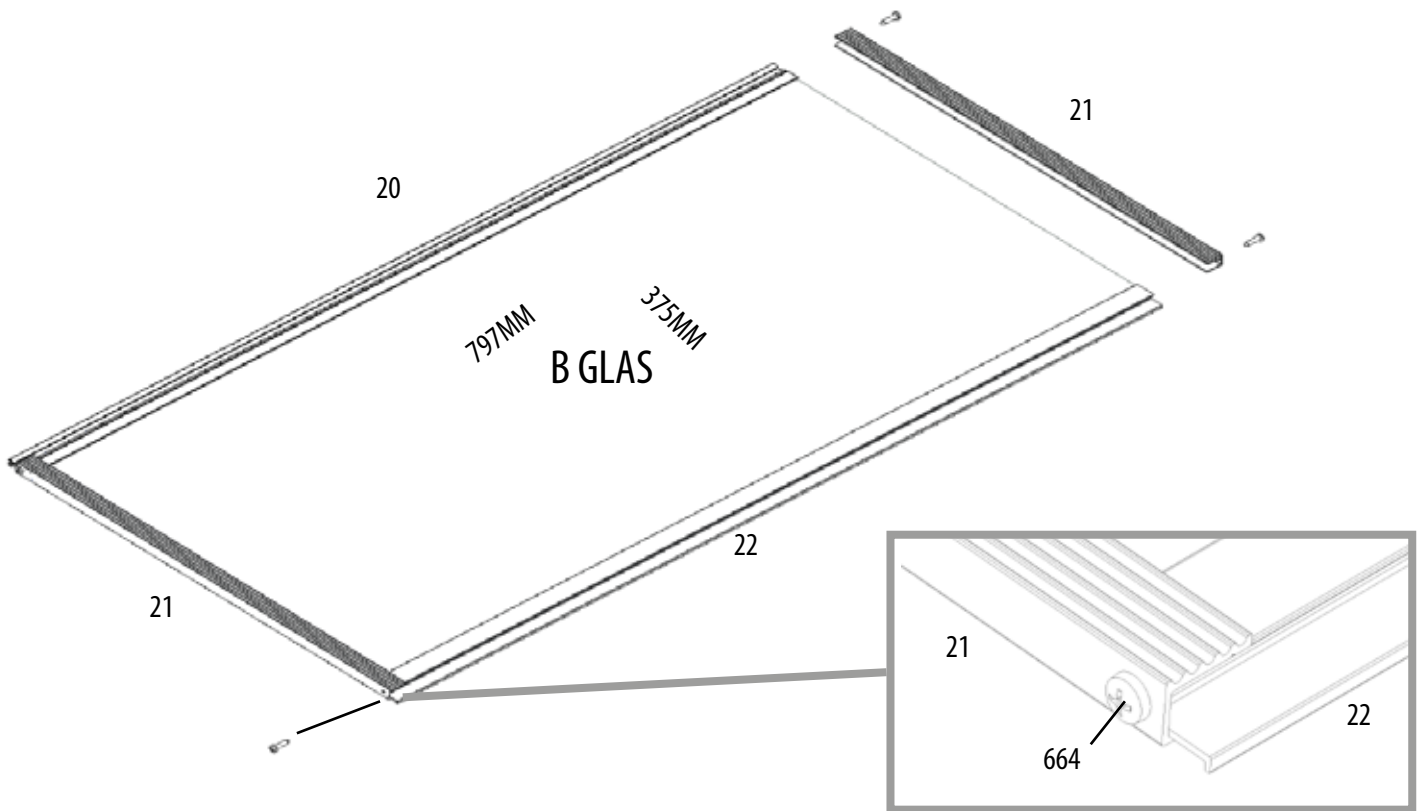

# 56

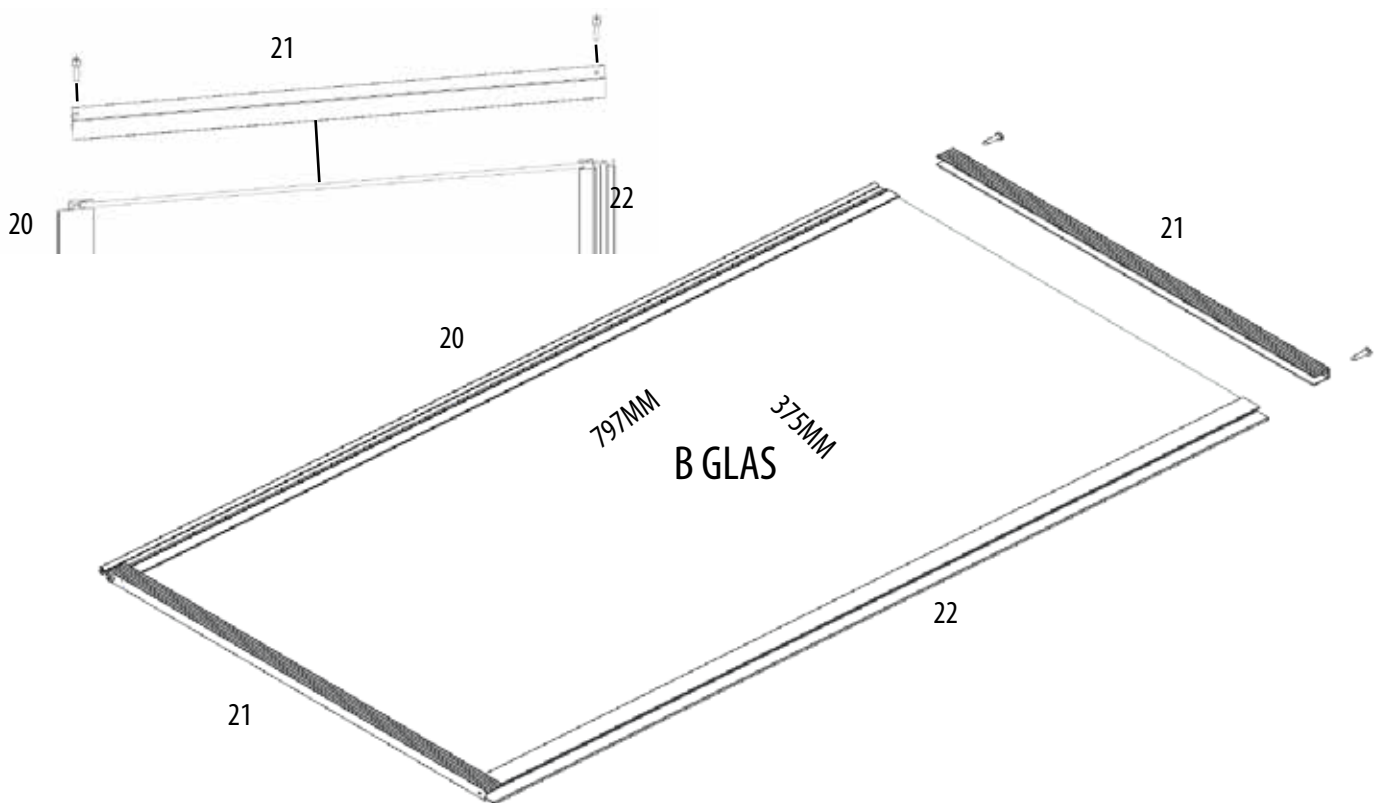

# 57

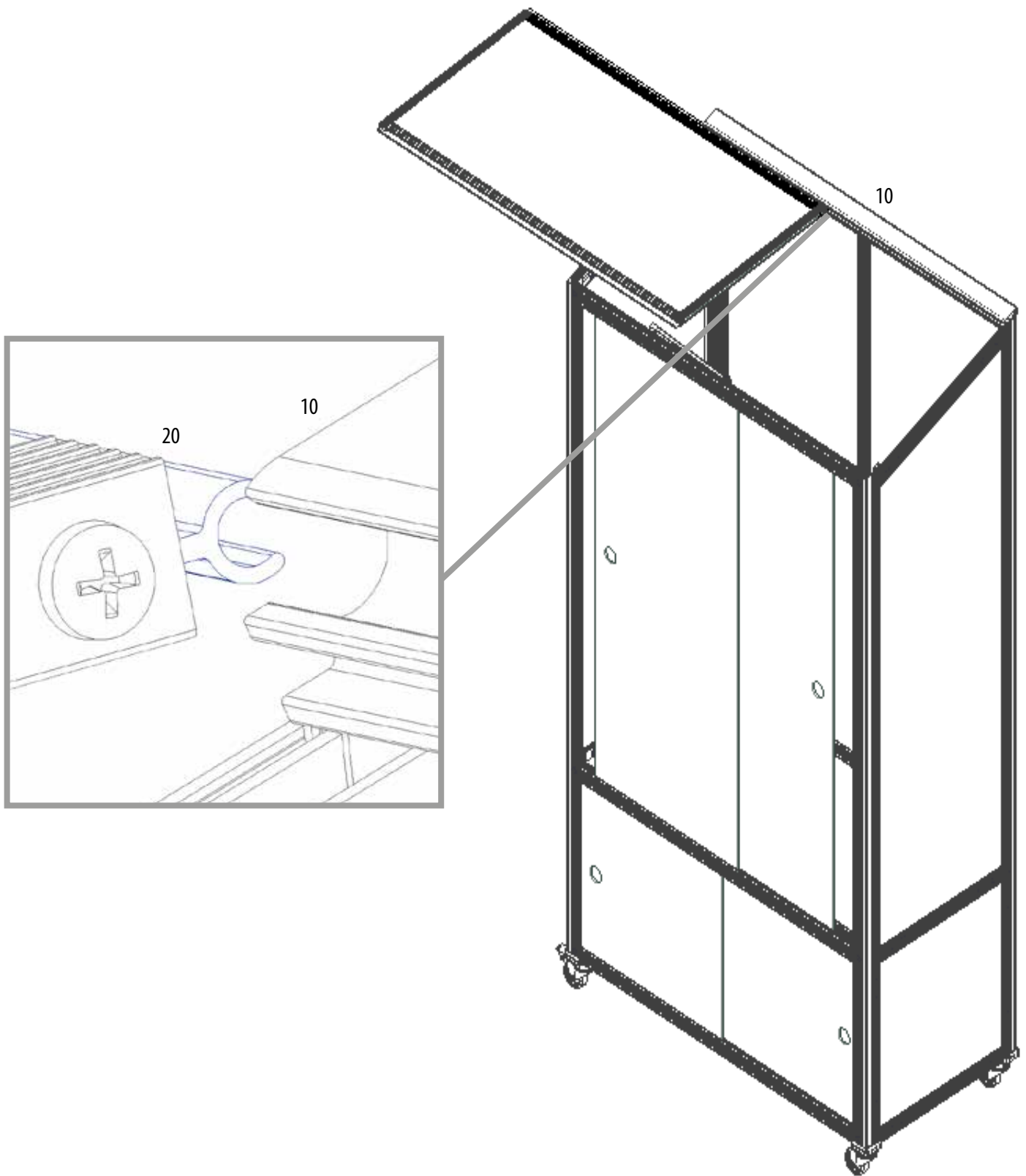

# 58

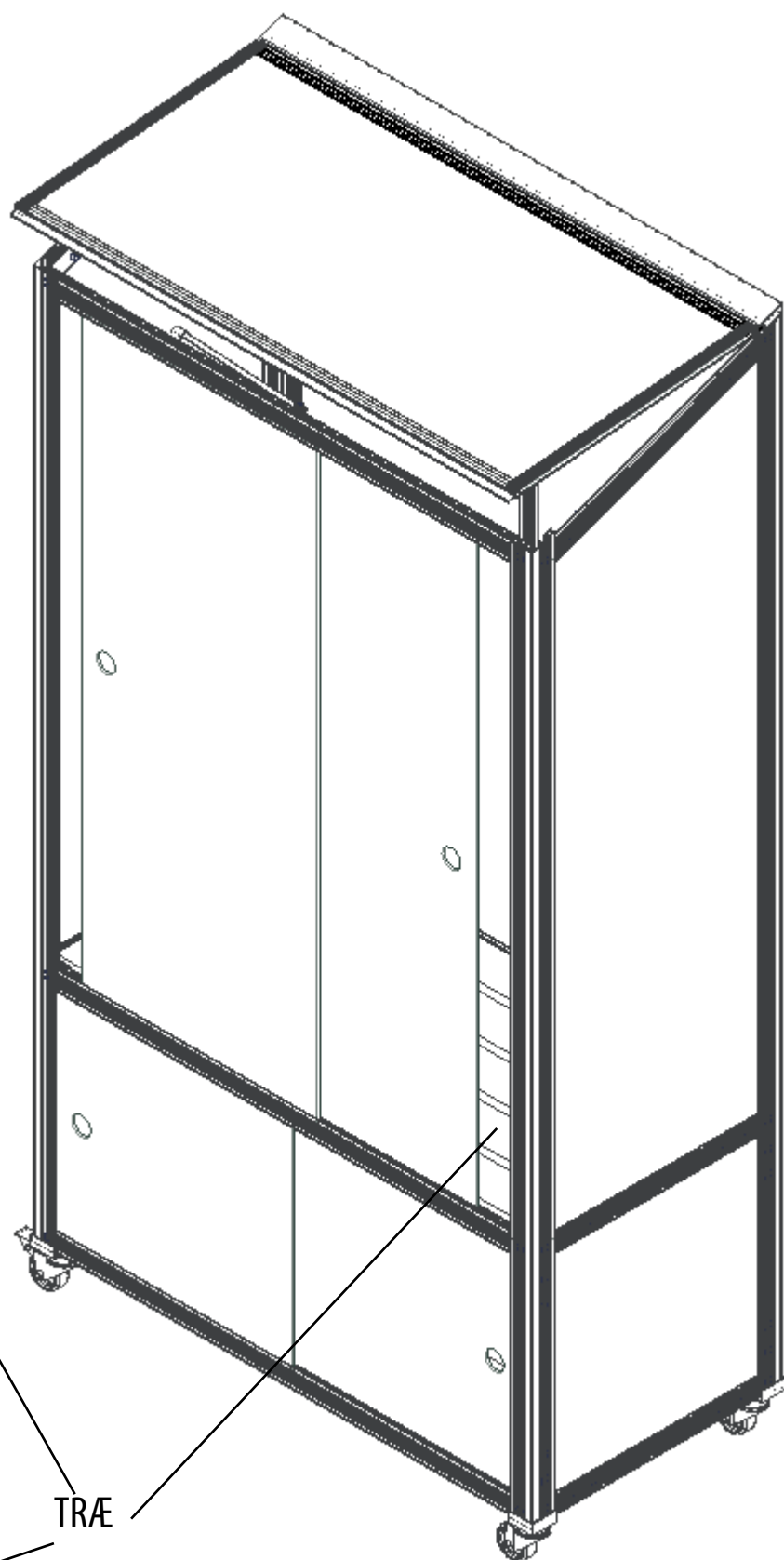
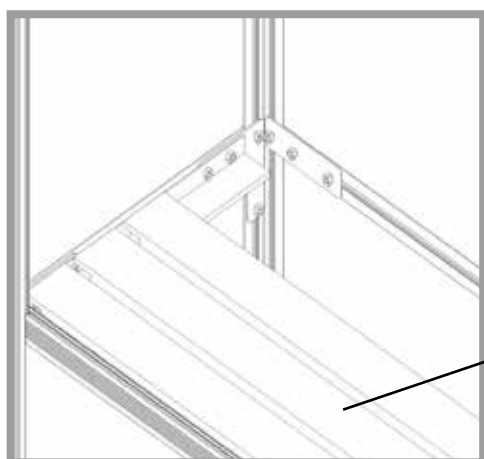
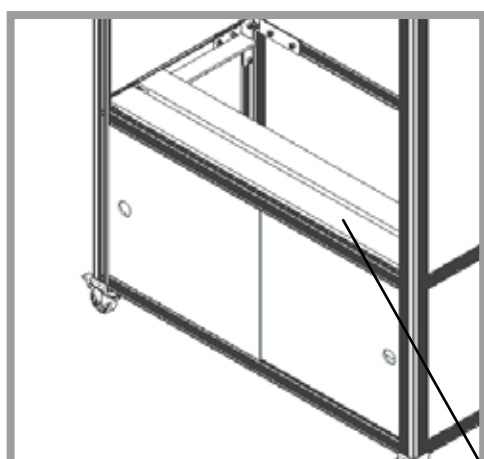
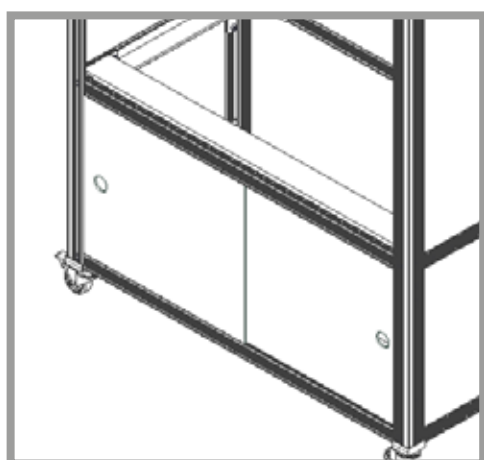
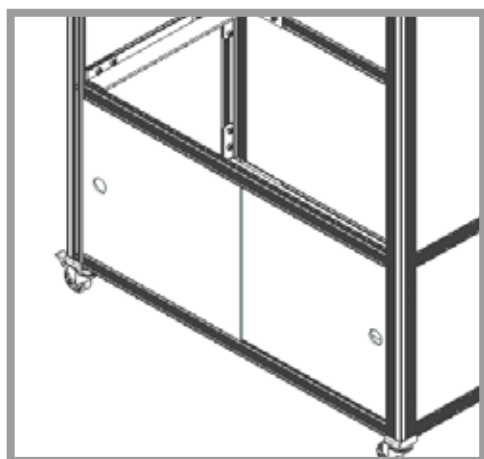

TRÆ

# 59

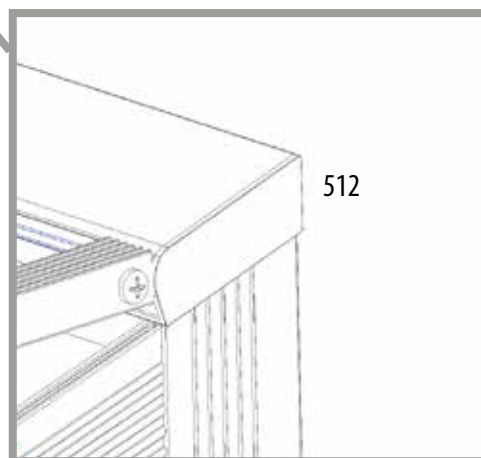
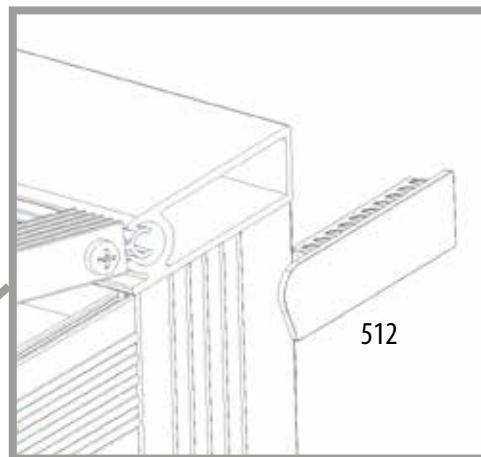
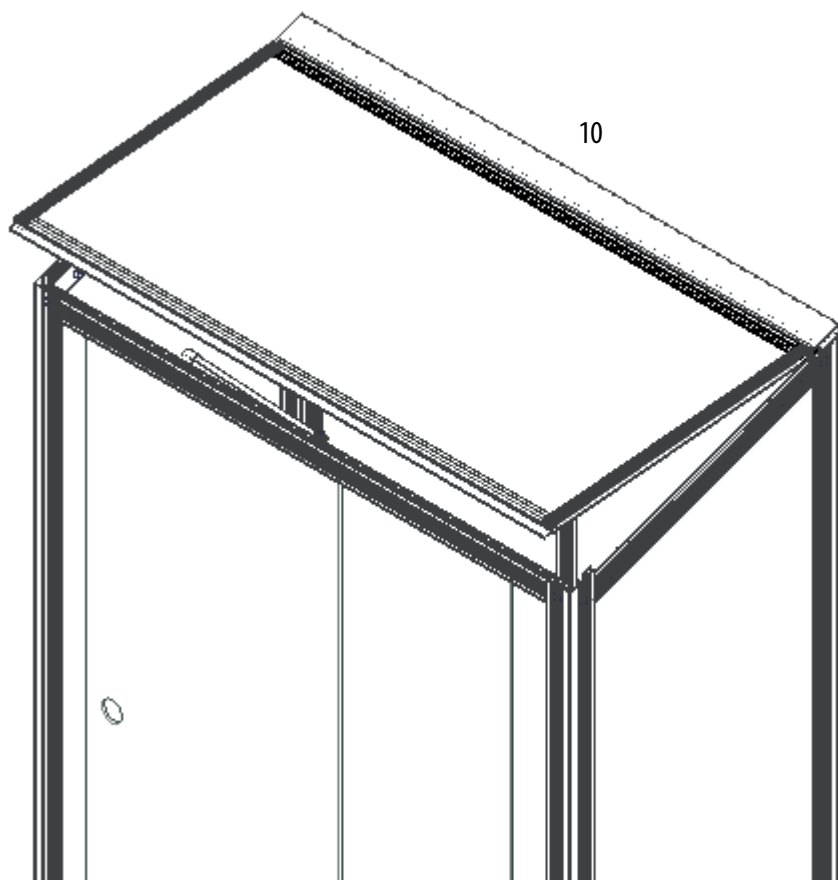

**1**

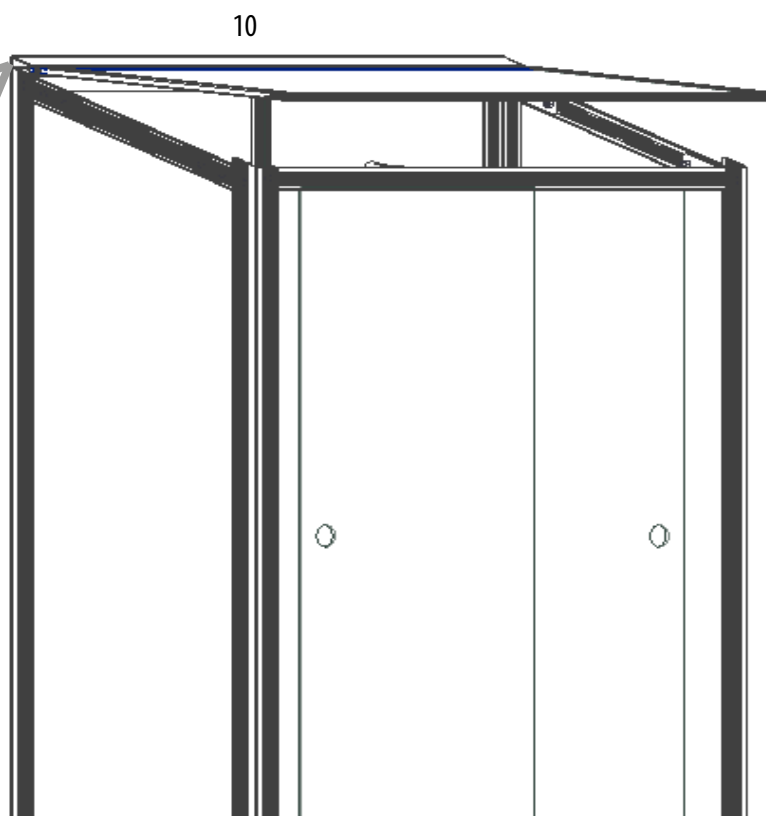
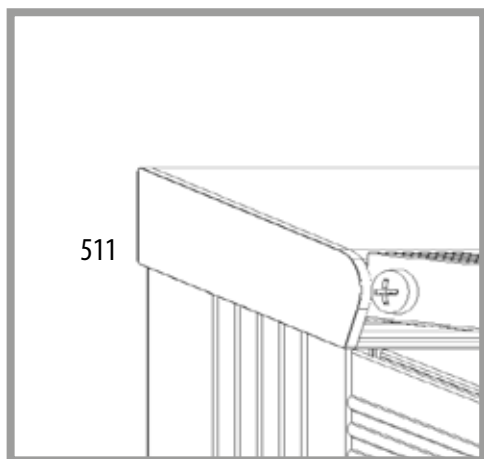
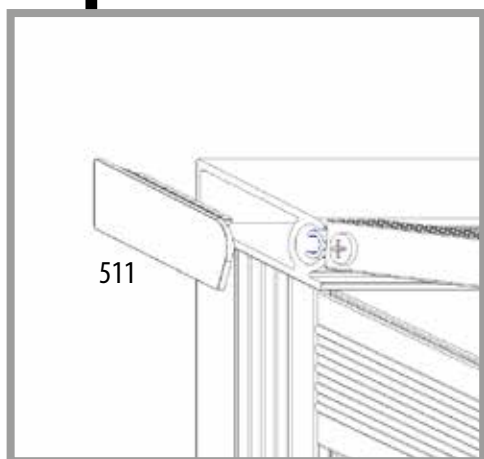



60

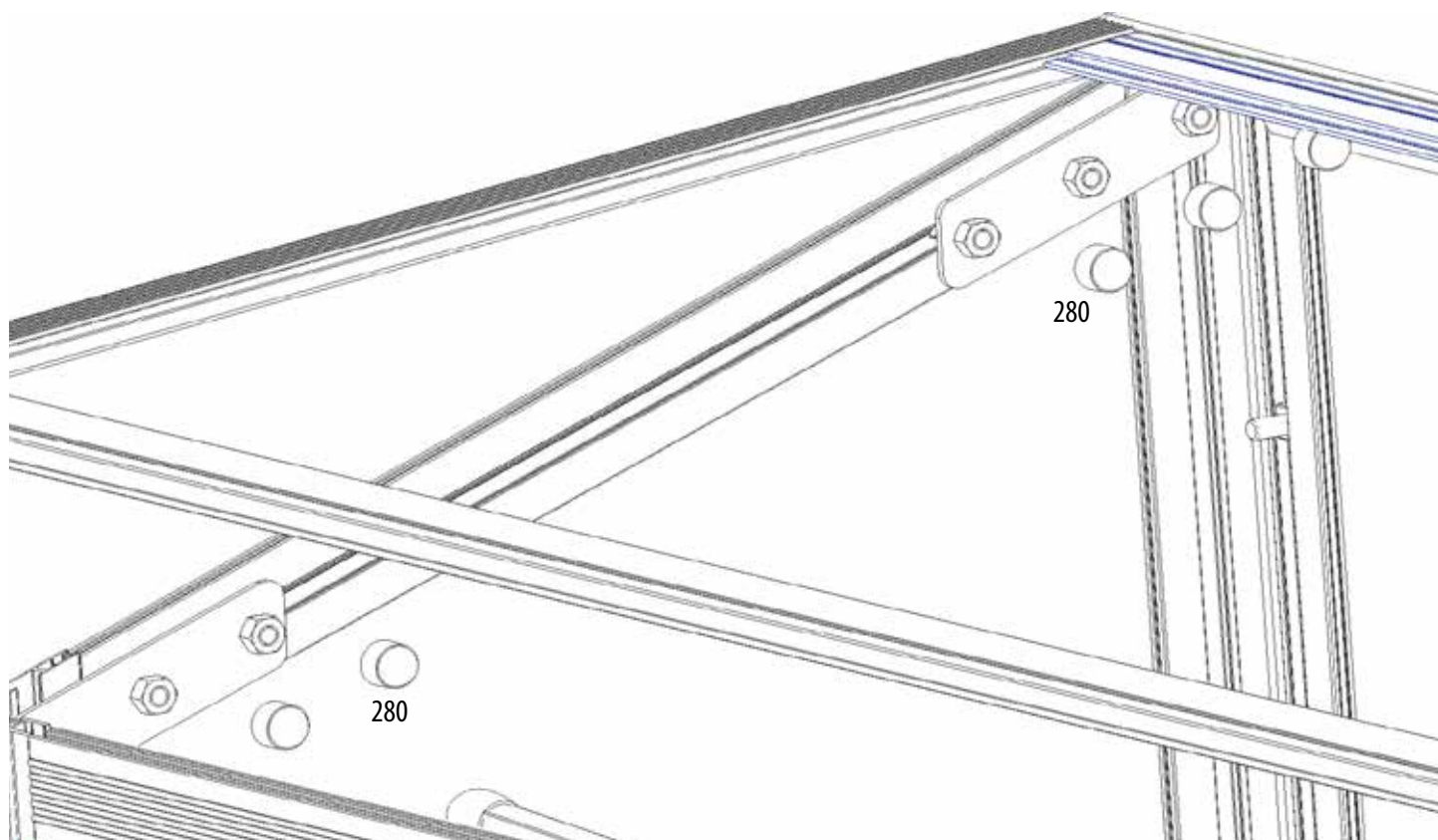

90 stk x 280

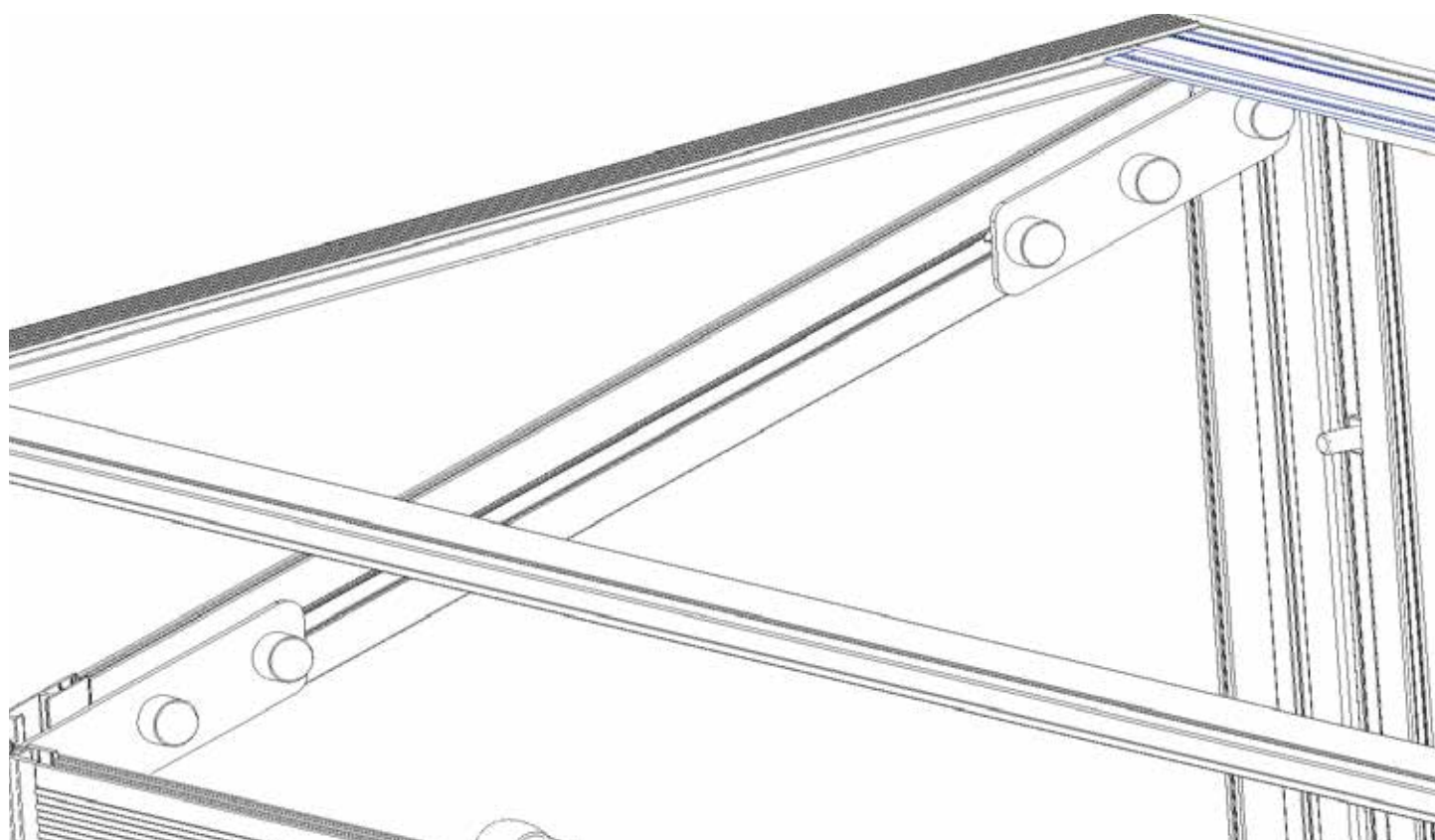

## Oversigt - overview - Übersicht - Översikt

#	Part number	#	Part number
05	16-13521488-05S	364	00310364
051	16-13521488-051S	M10	00300706
052	16-13521363-052S	M10x25	00300700
053	16-13521363-053S	M6	00401150
10	16-13780800-10S	73B	00300450
01	16-13511088-01S	73C	00310202S
01-1	16-13510331-01S	73D	00300629
01-2	16-13510727-01S	73E	00300407
25	16-13790777-25S	78B	00300615
01-3	16-13510326-01S	84	00300610
02	16-13510345-02S	80	00300617
021	16-13510345-021S	79	00300616
21	16-13570393-21S	280	00402280
20	16-13550798-20S	664	00300664S
22	16-13560798-22S	77	00310205S
23	16-10530200-23S	<b>4mm Hærdet glas - Tempered glass - Sicherheitsglas - Härdet glas</b>	
30	16-10020320-30S		
360mm	F04572	A	00281539
760mm	F4573	B	00281540
508	00300508	C	00281541
509	00300509	D	00281542
511	00300511	E	00281543
512	00300312	F	00281544
27	00310359S	G	00281545
28	00310360S		
93-1	00310338S		
29	00310361S		