

S017

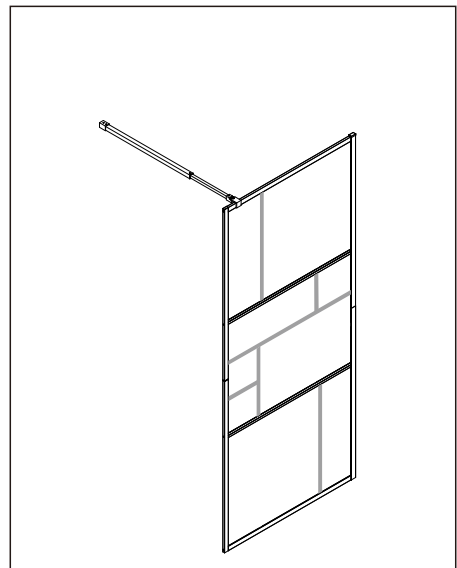

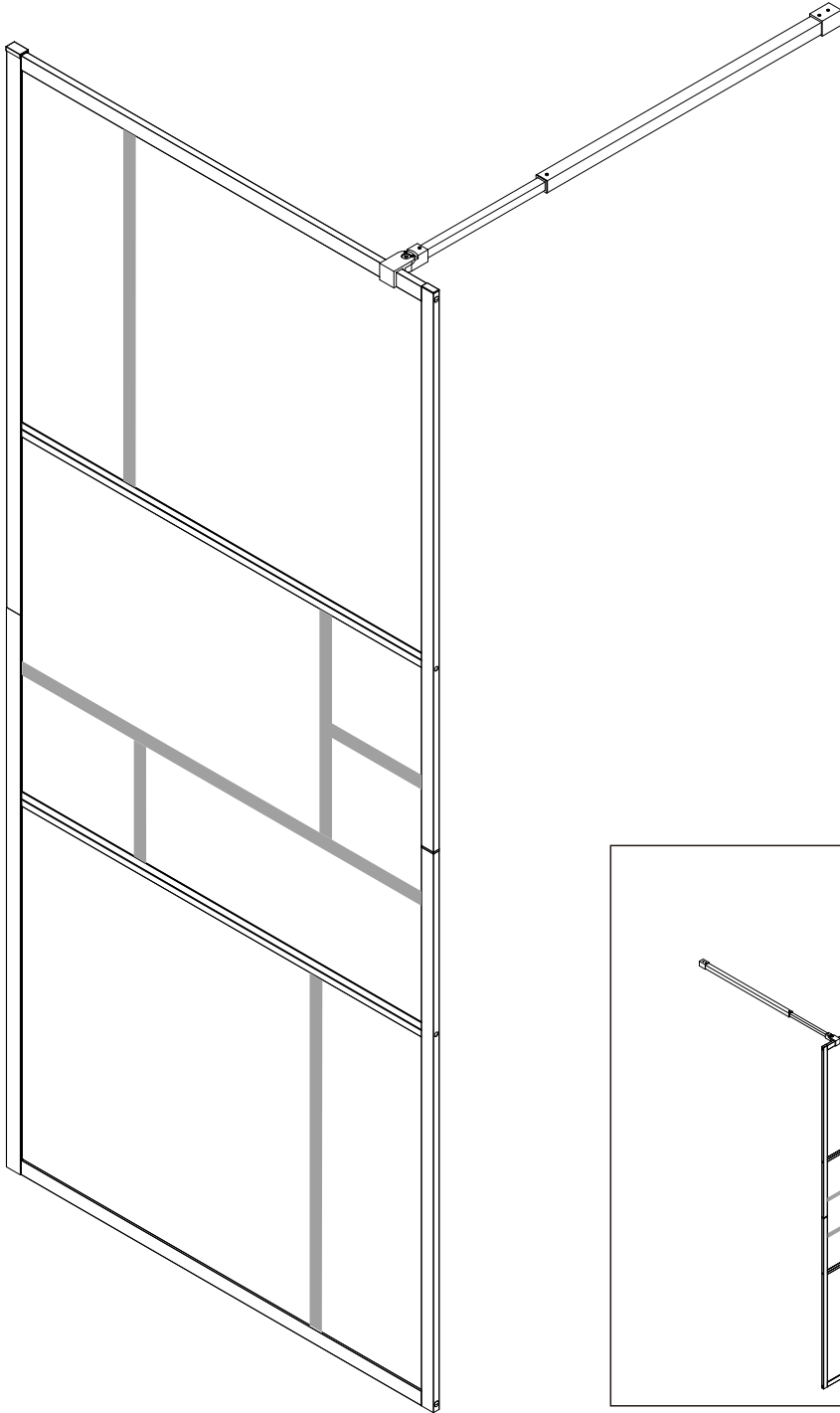

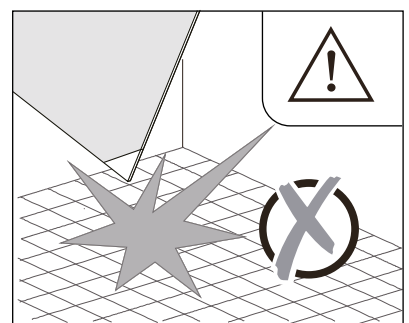
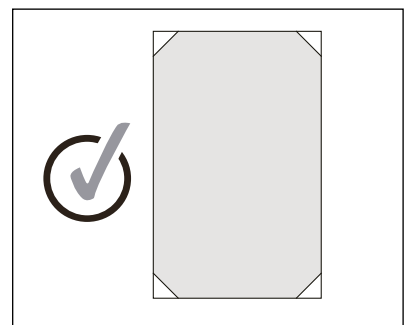
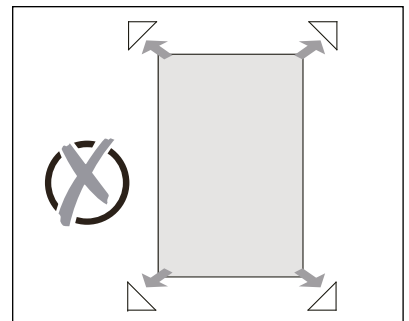
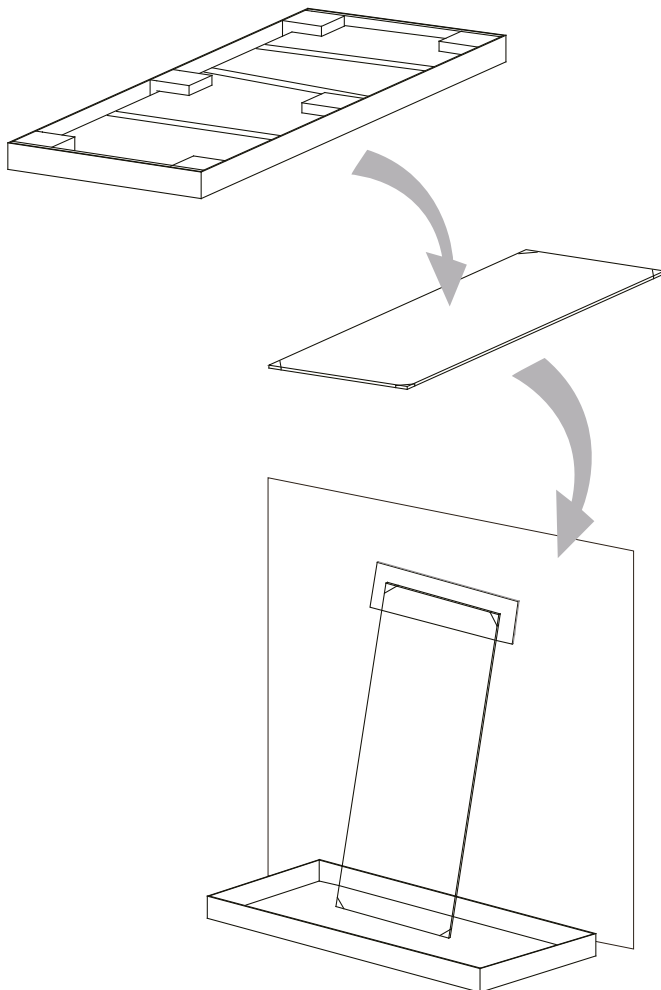
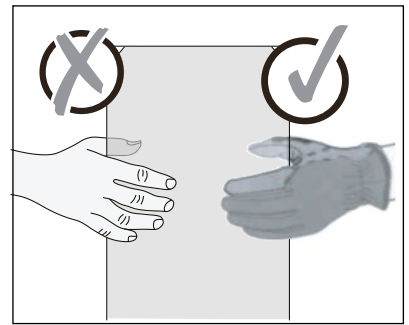
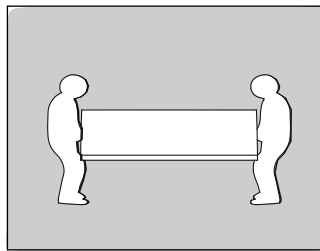
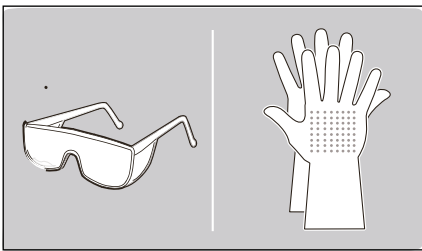
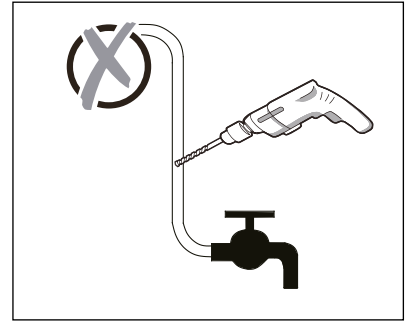
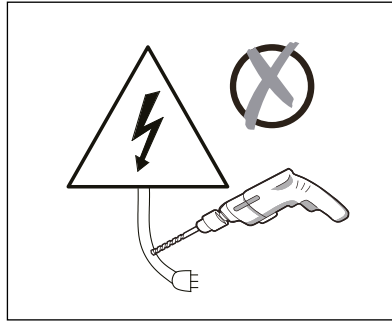
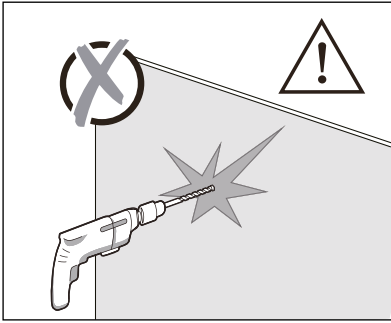
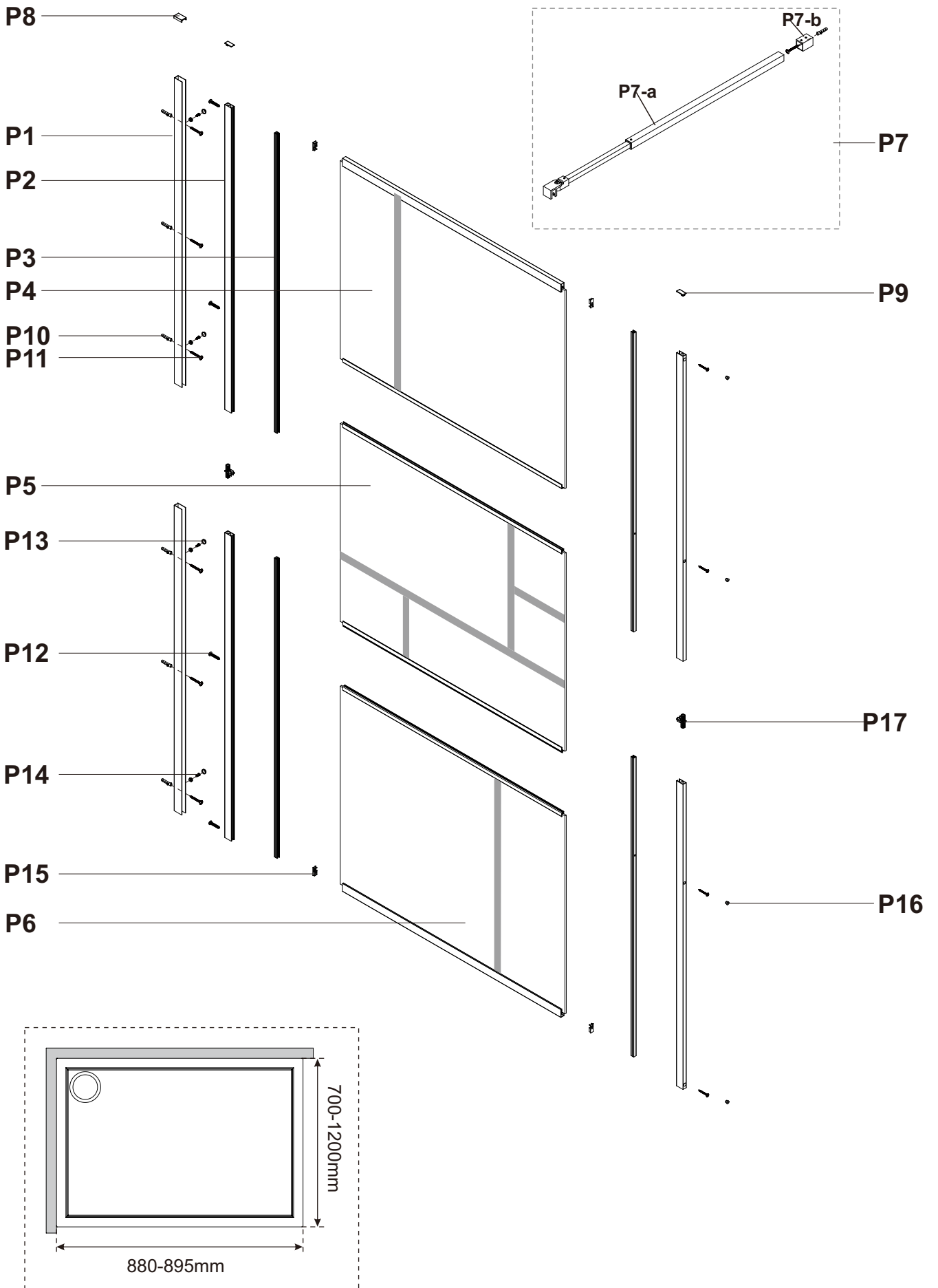

P1 X2	P2 X4	P3 X4	P4 X1
P5 X1	P6 X1	P7 X1	
P8 X1	P9 X2	P10 X6	P11 ST4X30MM X6
P12 ST3.5X40MM X8	P13 X4	P14 ST4X10MM X4	P15 X4
P16 X4	P17 X2		

 Ø 6mm	
 Ø 6mm	
 ⊕ PH2	 ⊖ SL3.0X75
 Ø 3mm	

1

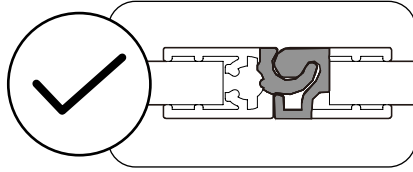
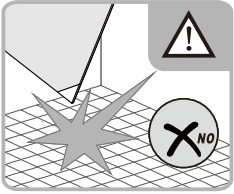
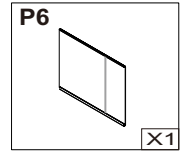
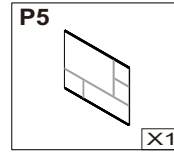
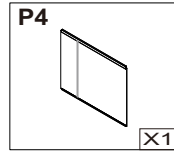
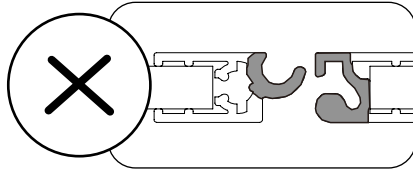

1.1

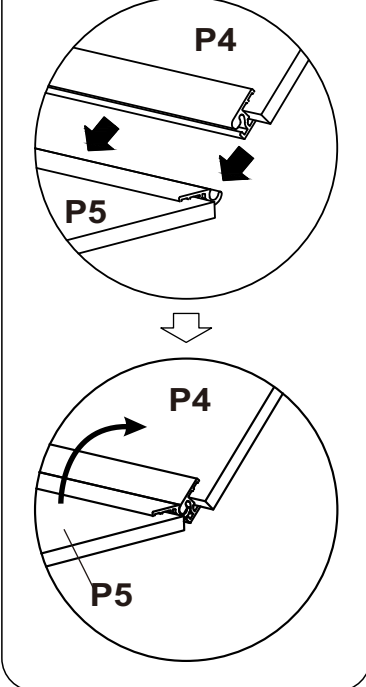

1.2

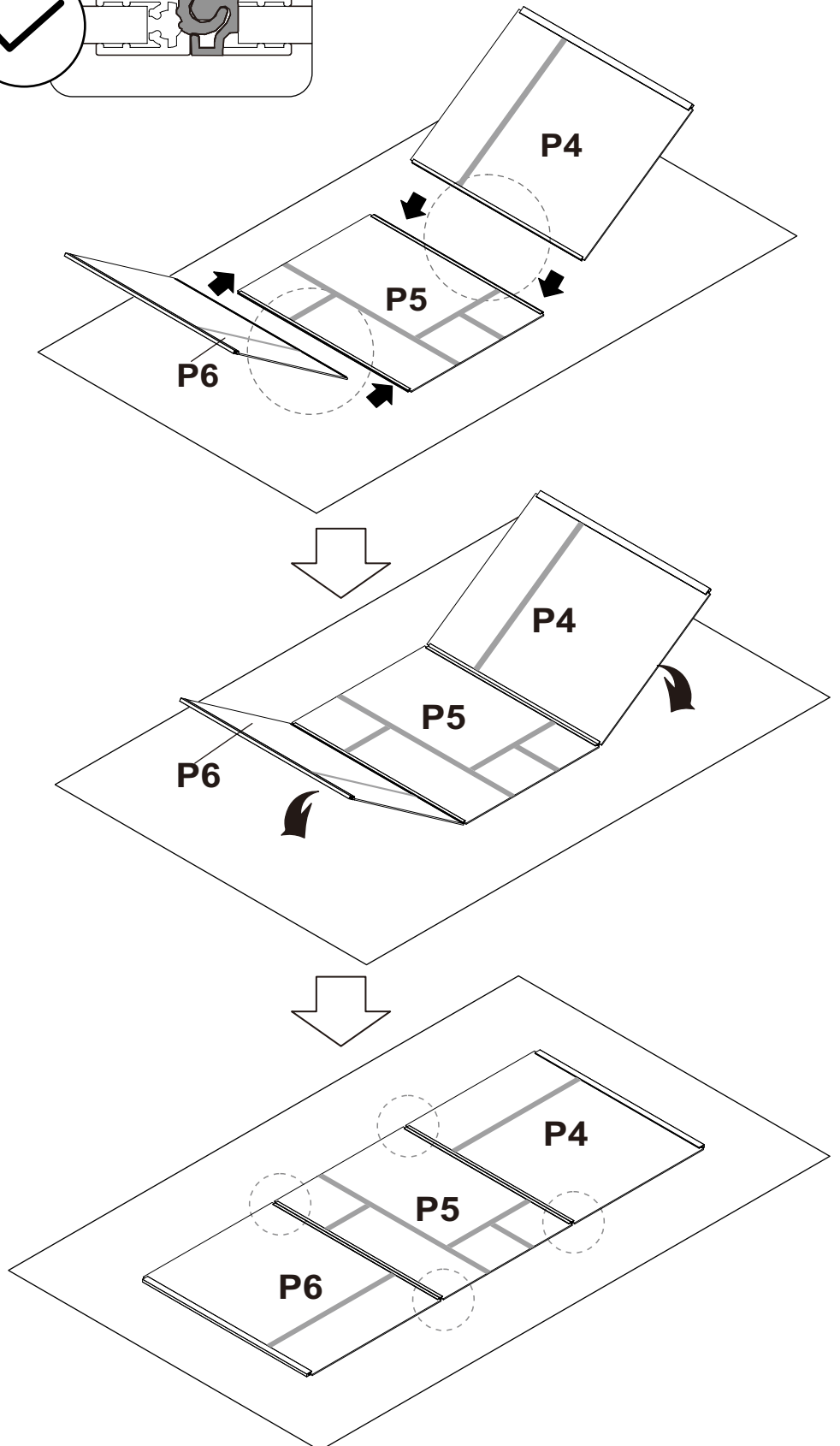
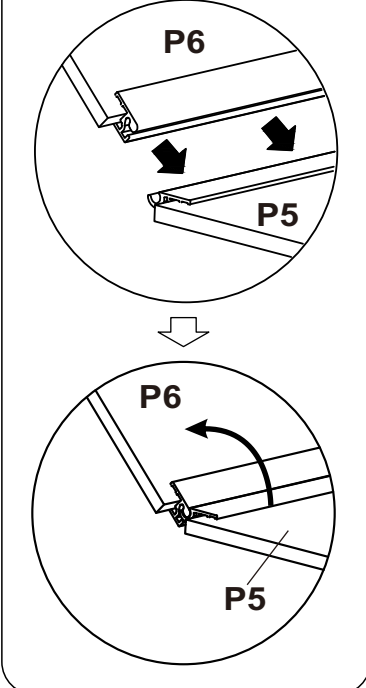



2

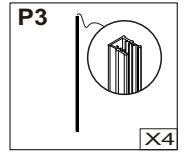
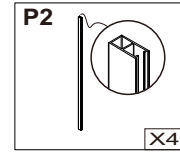

2.1

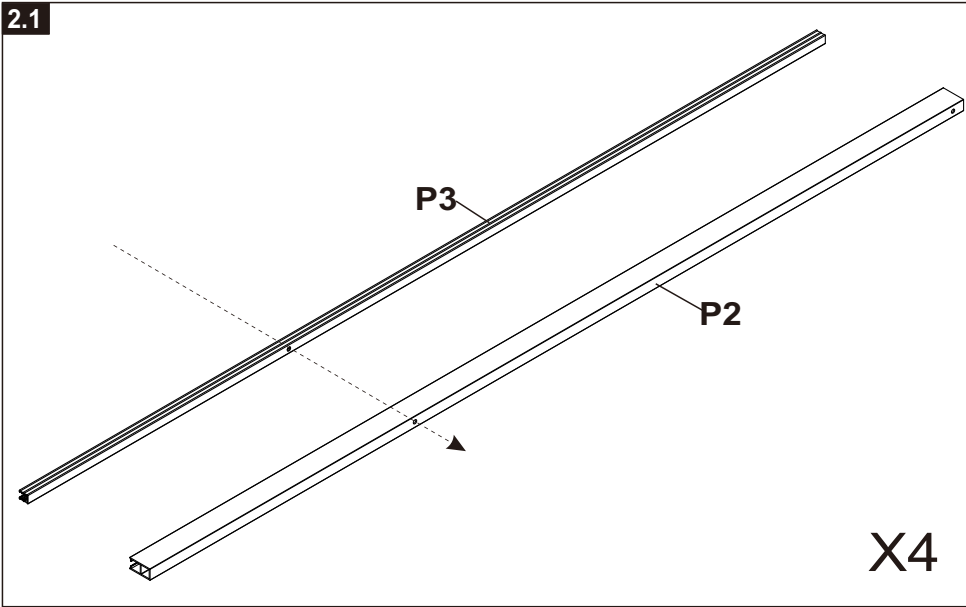

Löcher in Flucht
Holes in one line

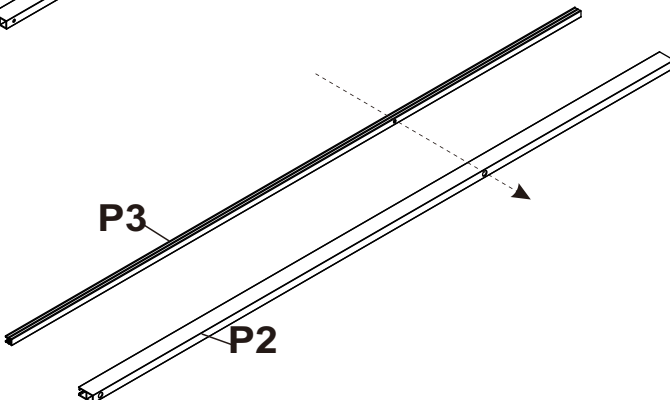
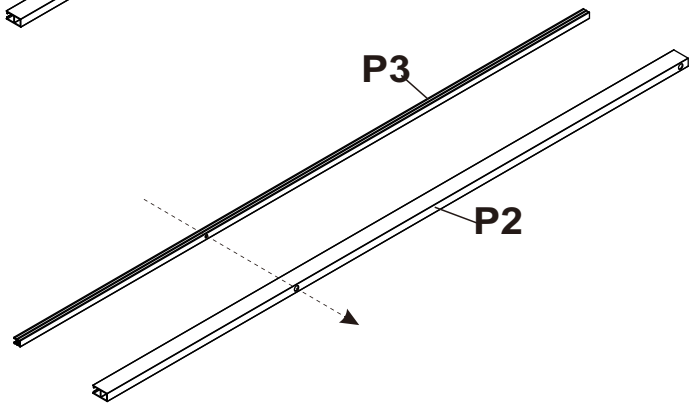
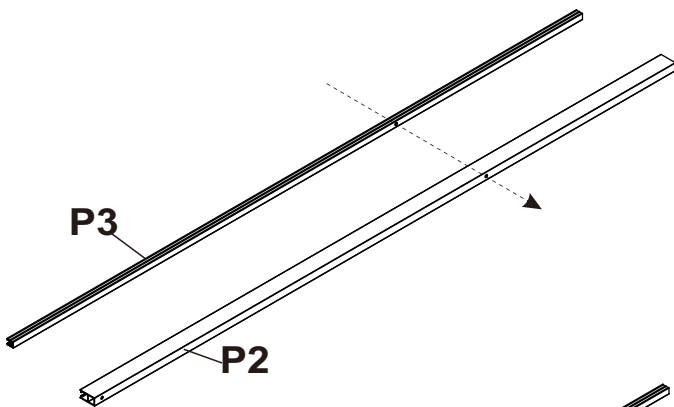
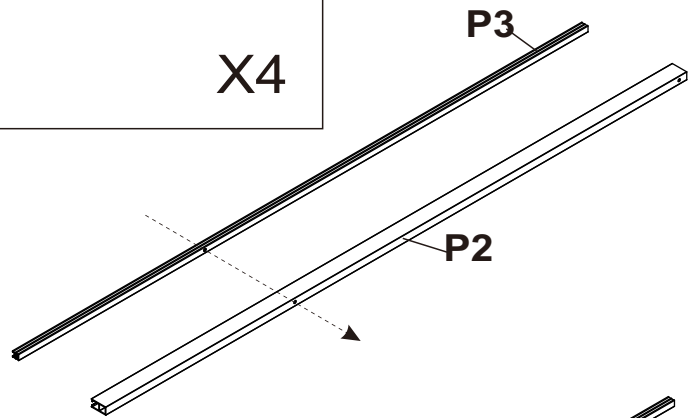

3

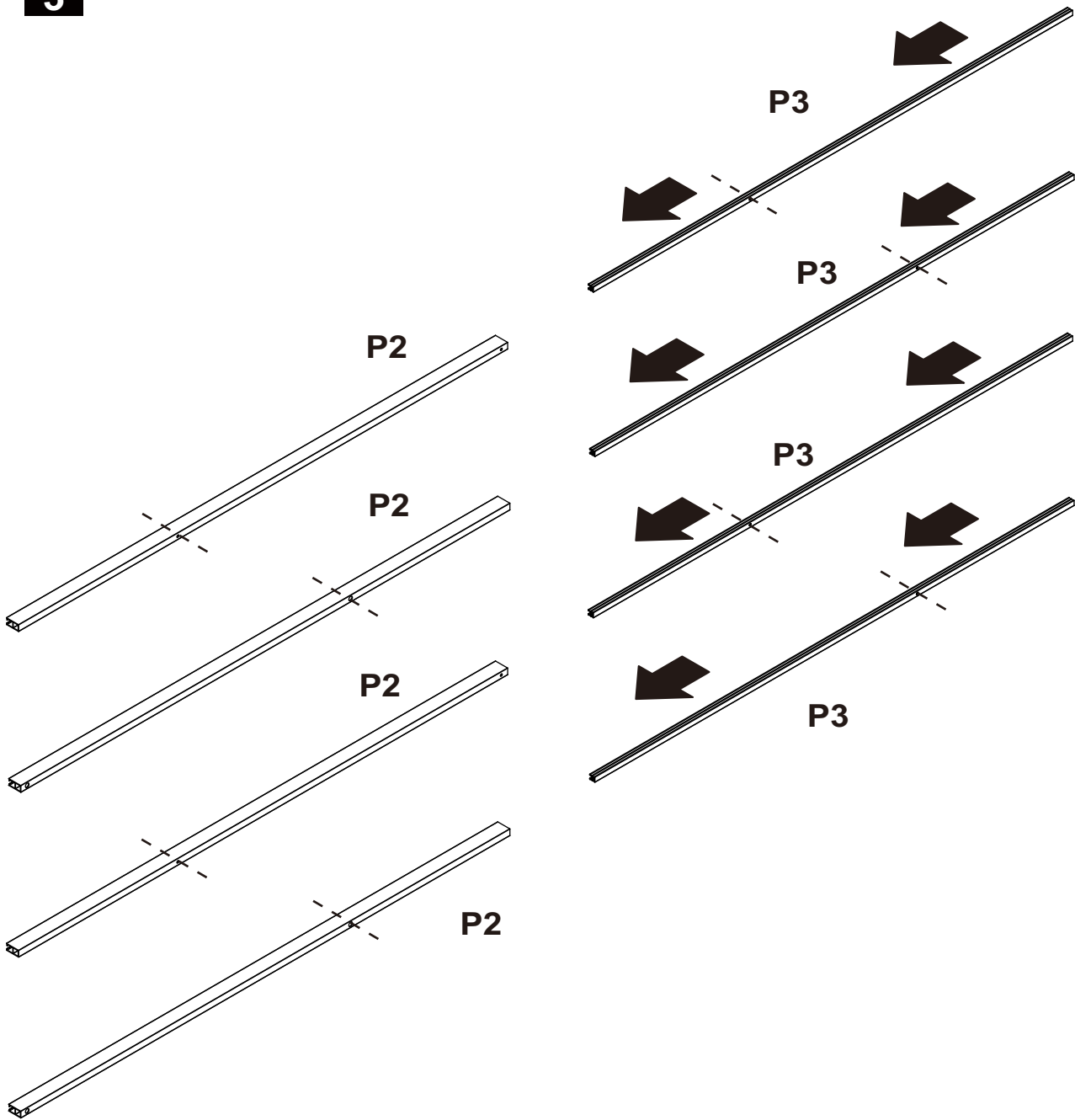

3.1

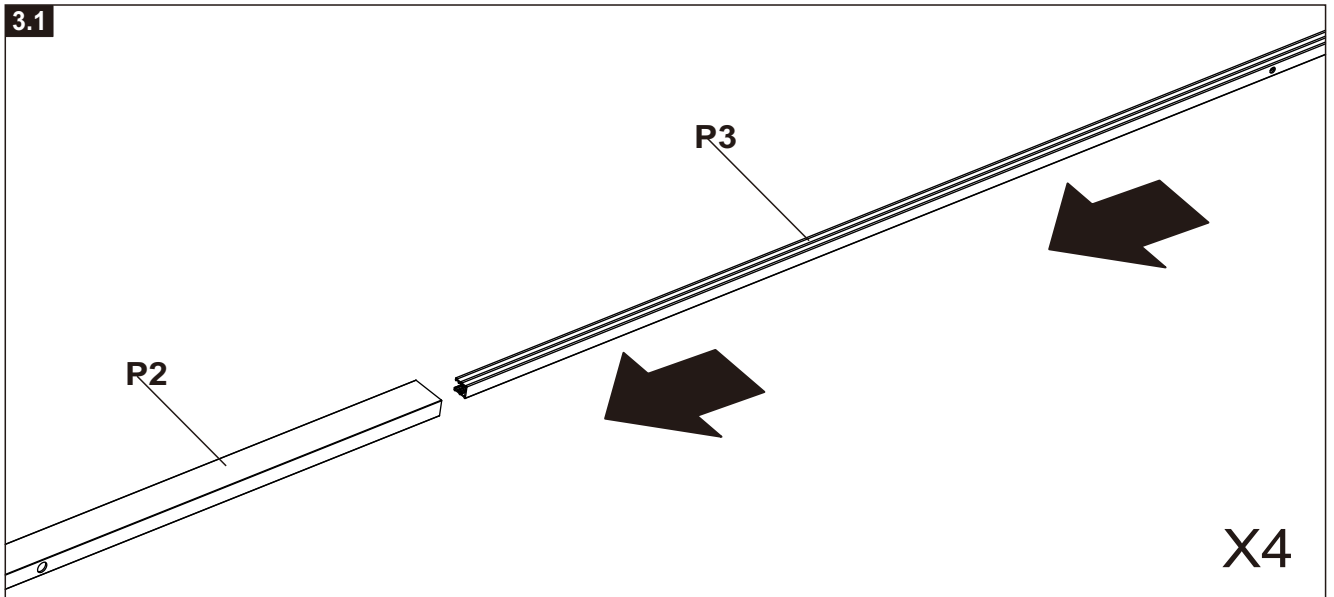

X4



4

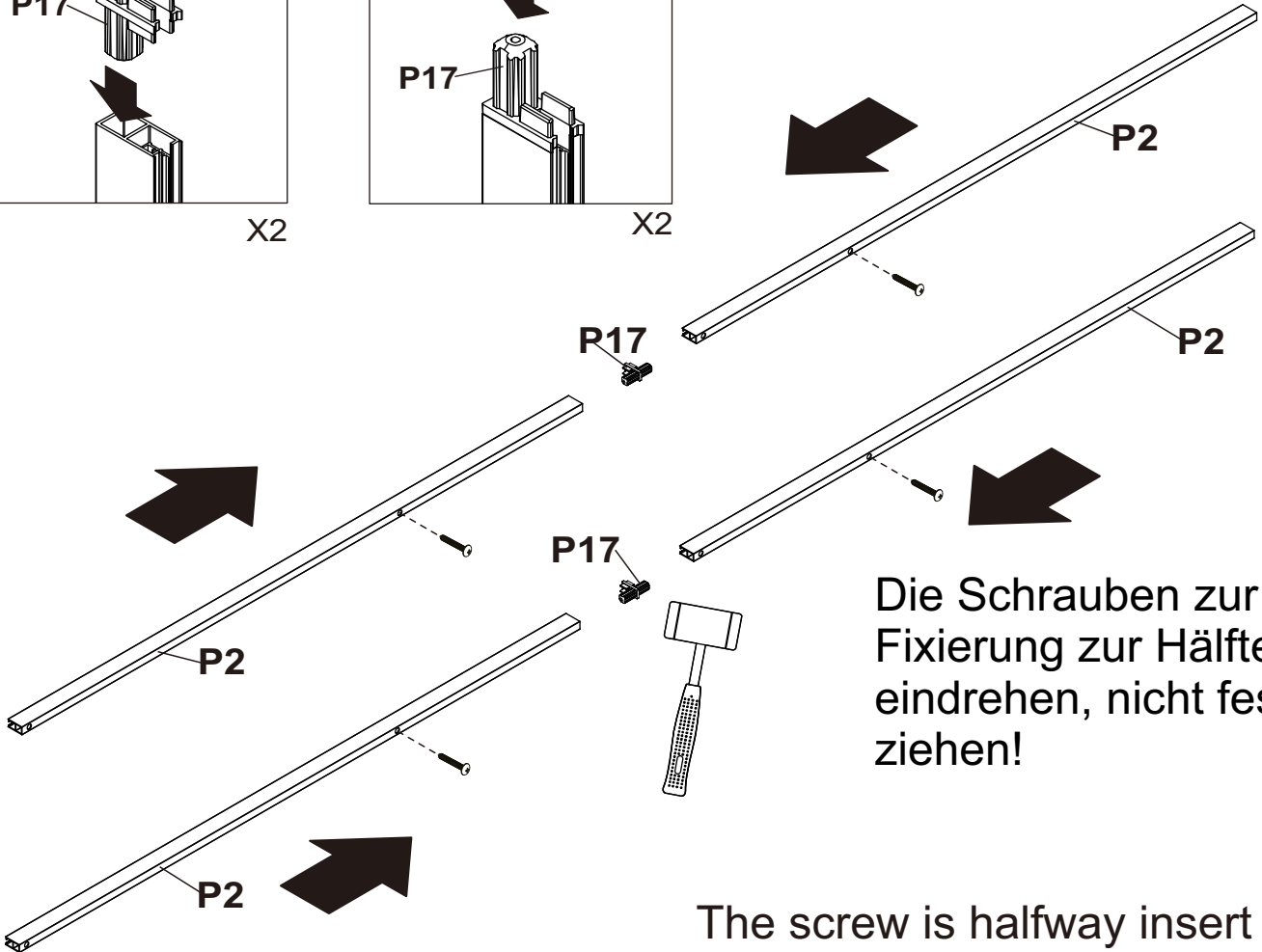
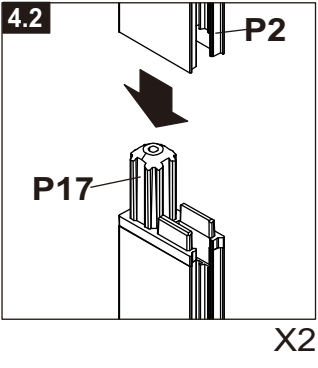
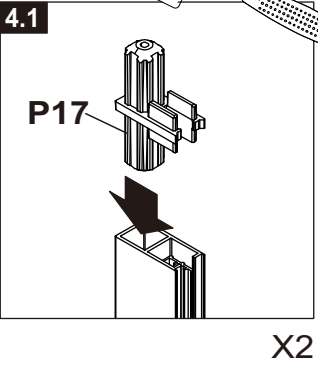
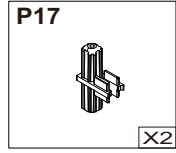

Die Schrauben zur Fixierung zur Hälfte eindrehen, nicht fest ziehen!

The screw is halfway insert not tightened, used to fix the hole position.

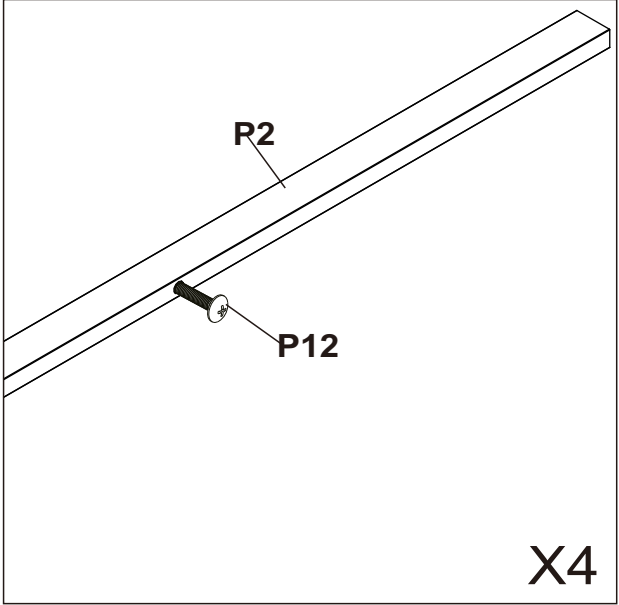
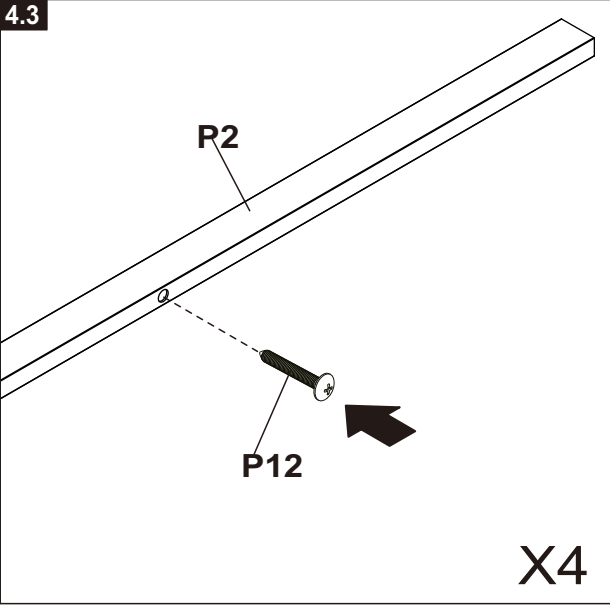



5

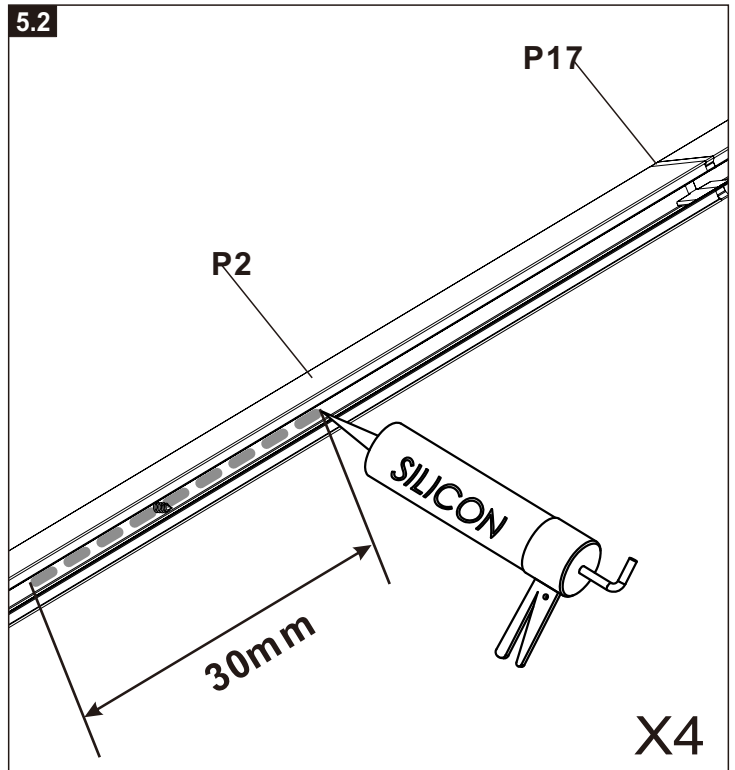
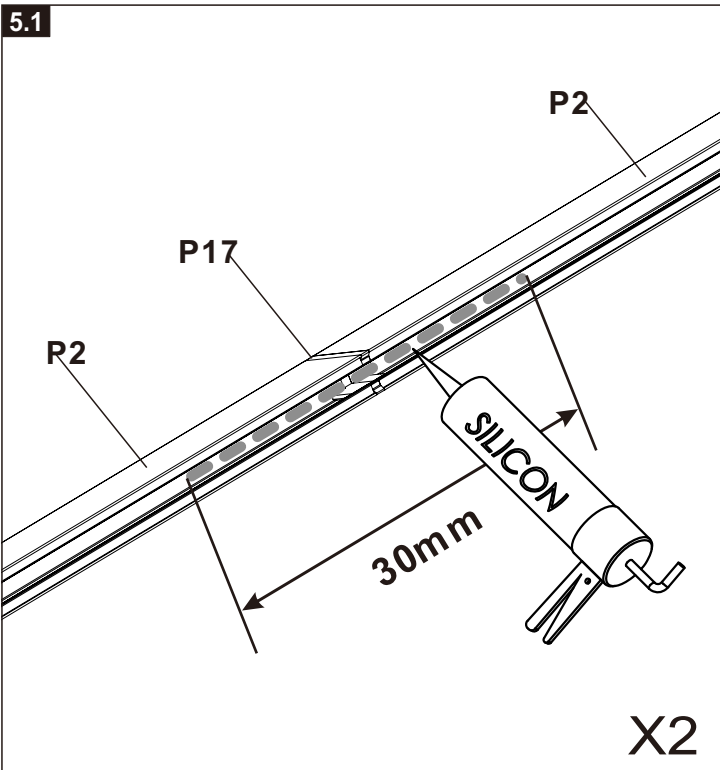
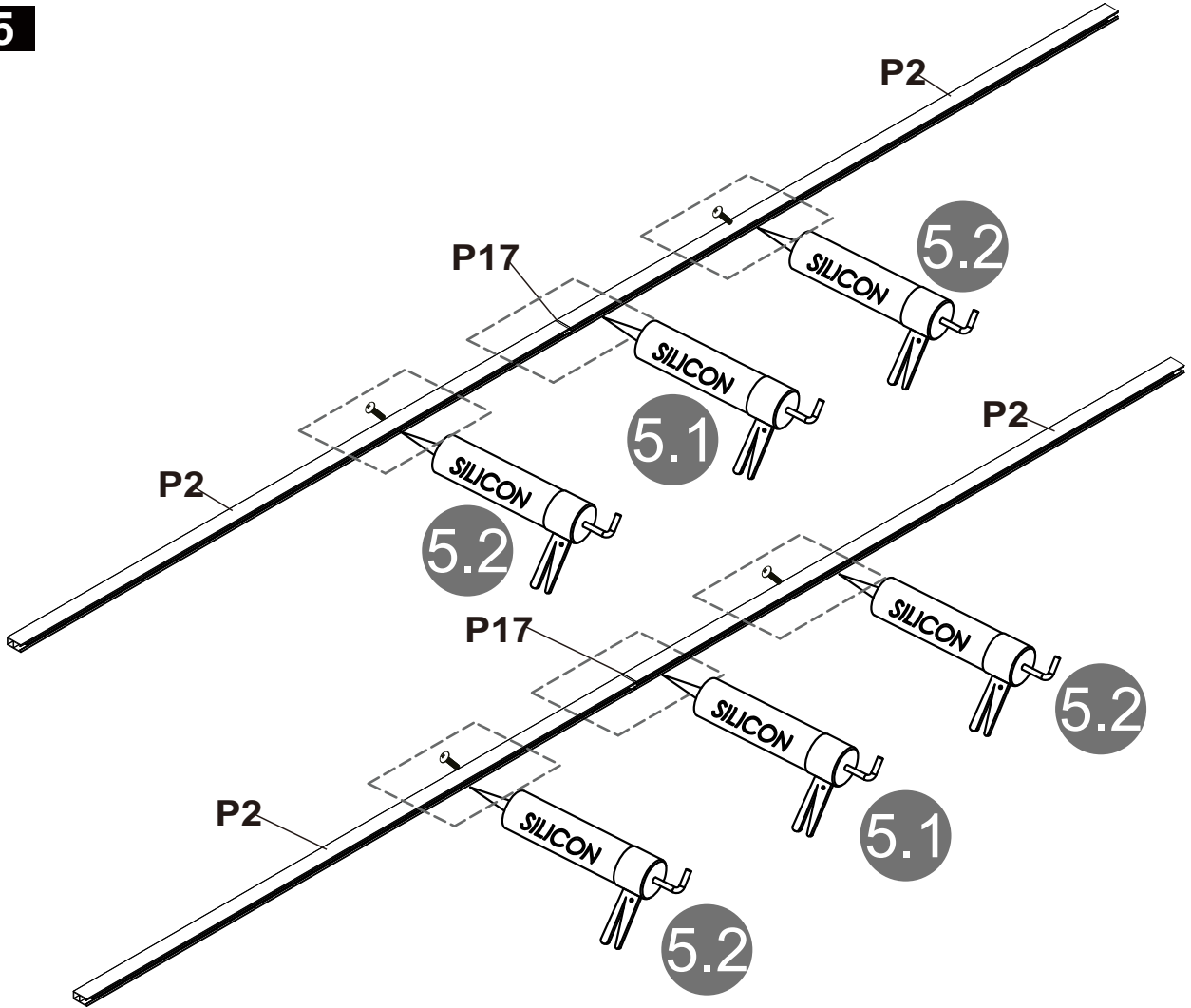

10



⊕ PH2

6

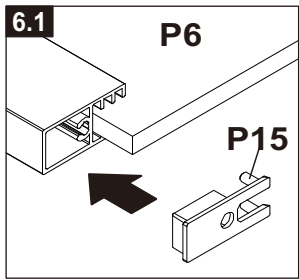
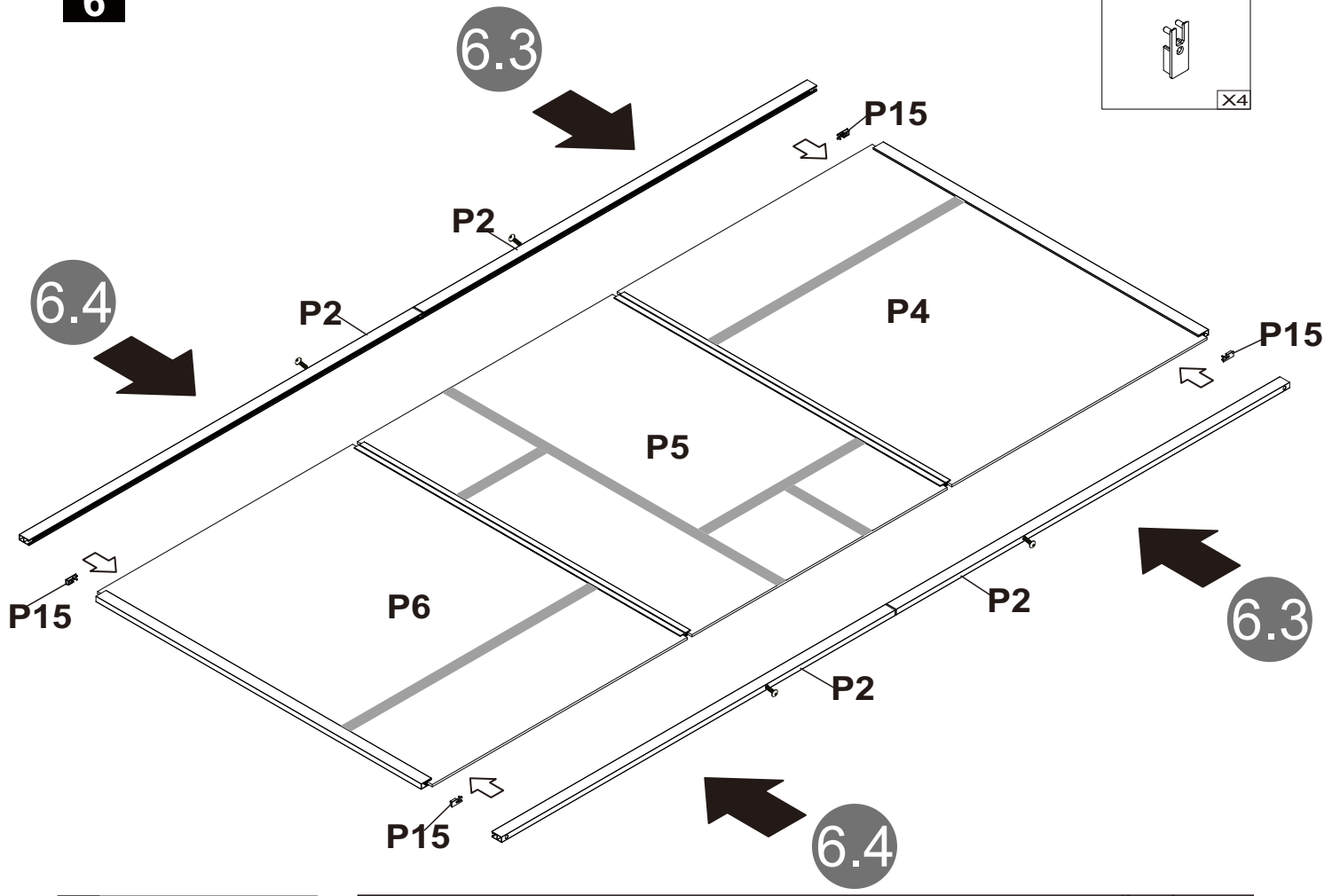
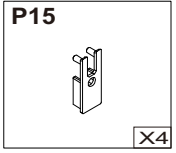

X2

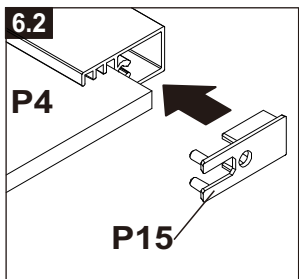

X2

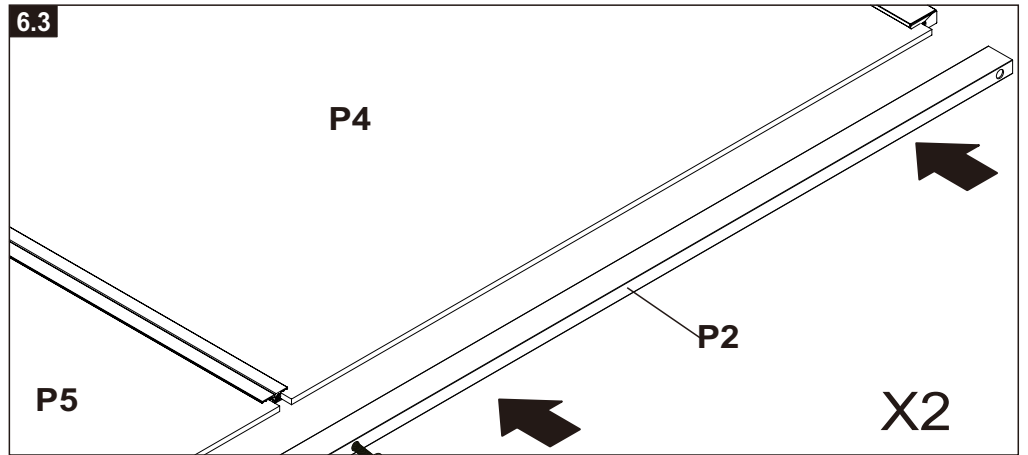

X2

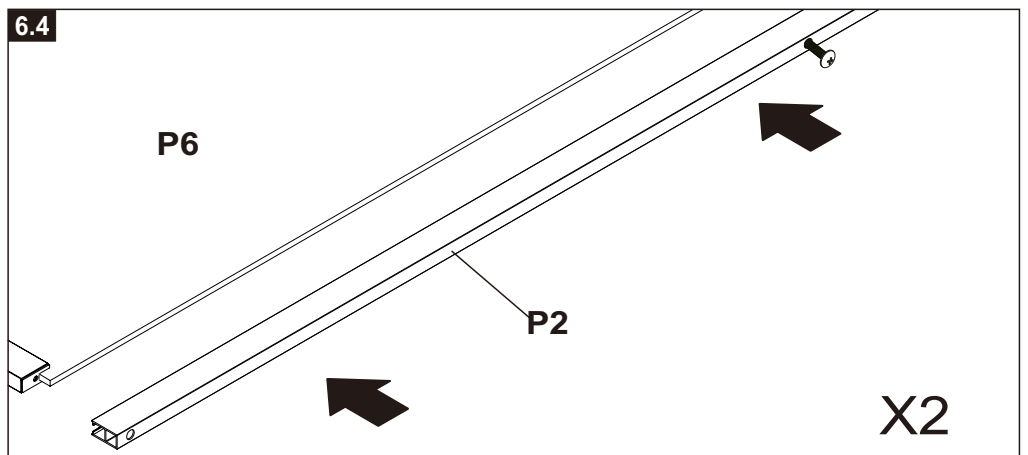

X2



⊕ PH2

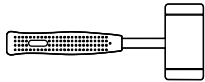

7

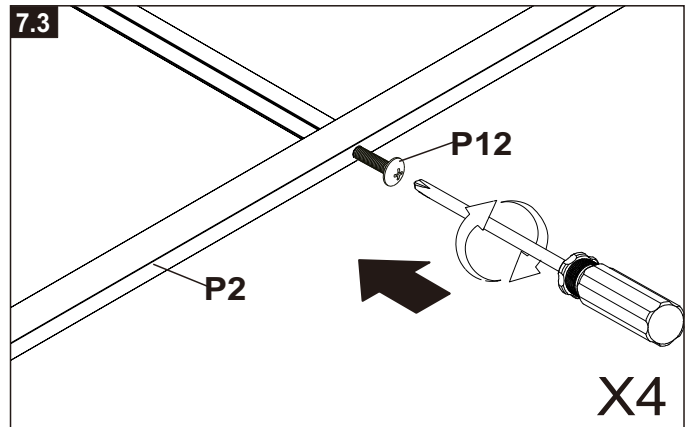
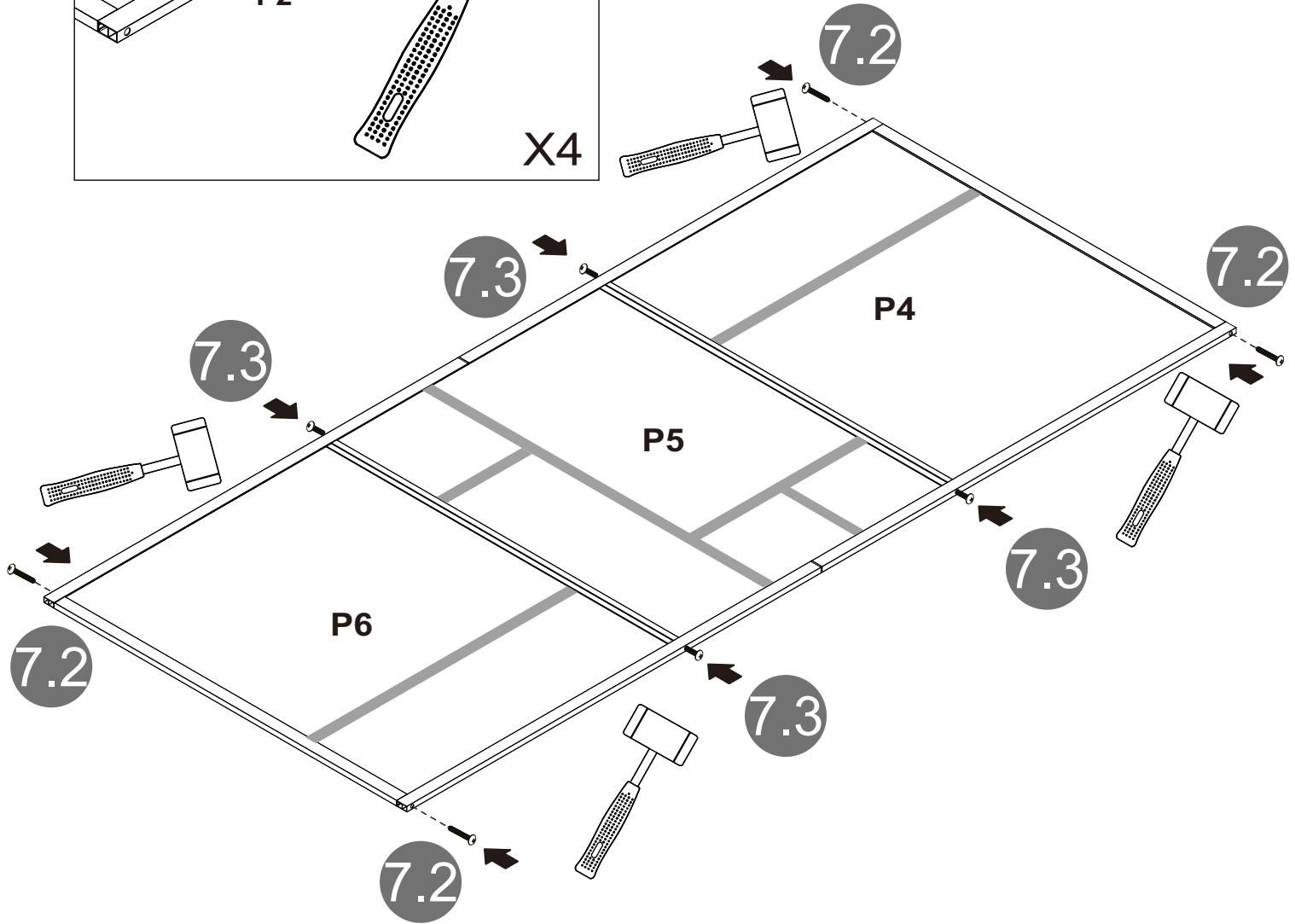
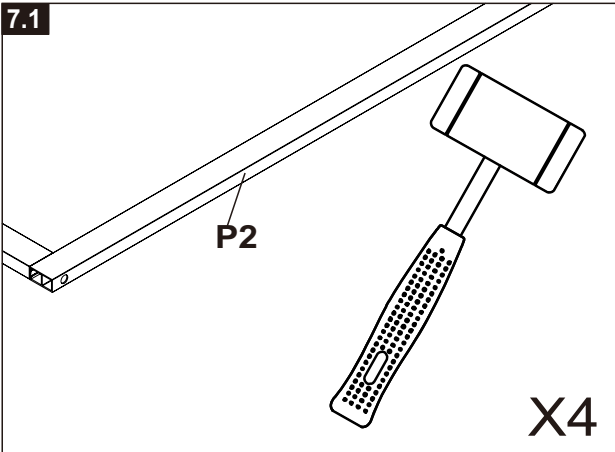

12

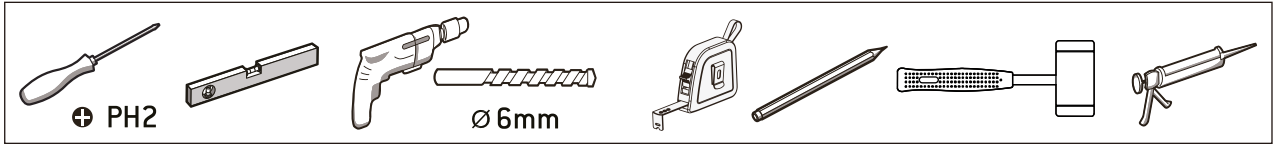

8

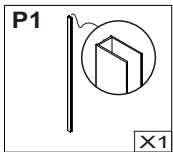
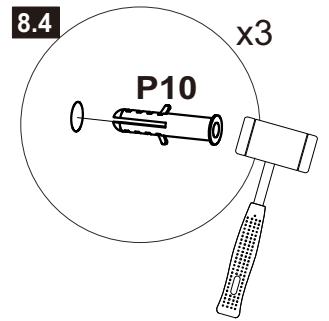
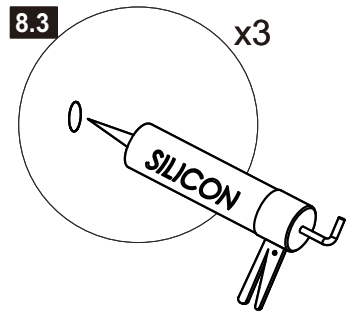
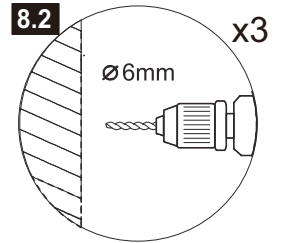
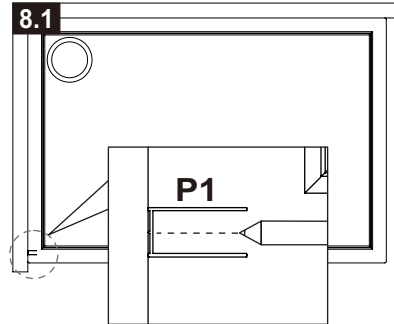
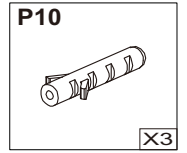
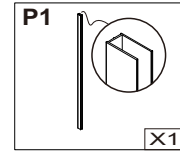
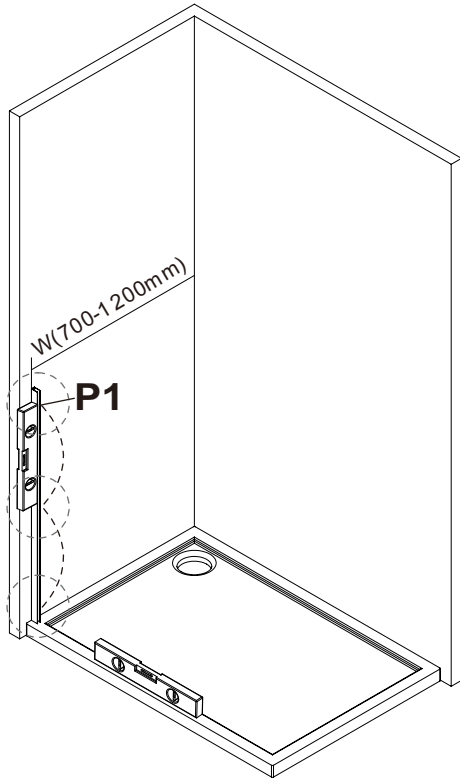

9

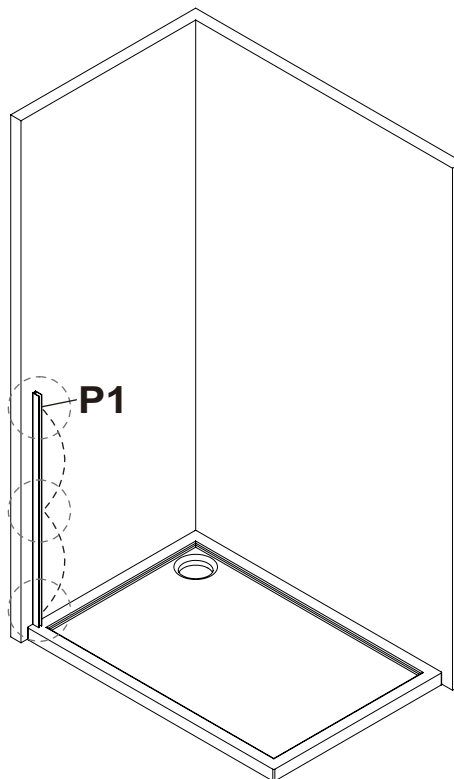
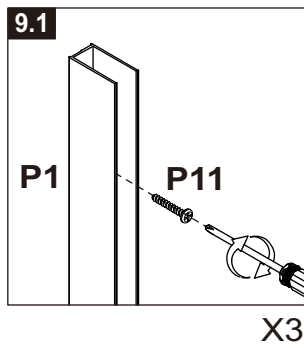

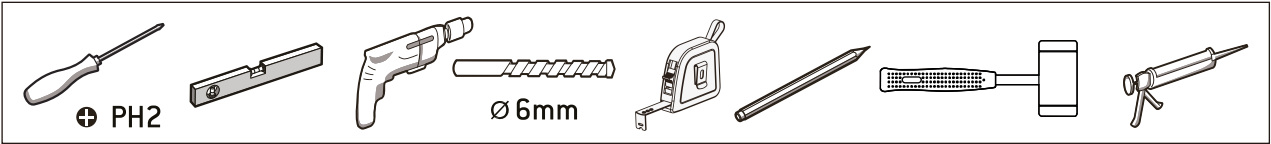

13

10

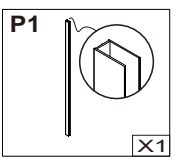
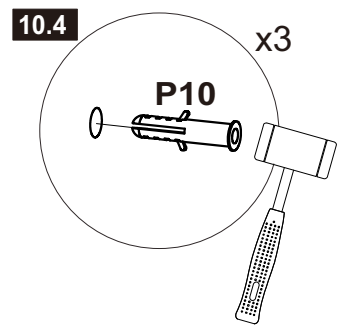
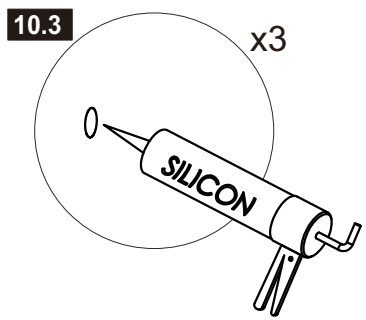
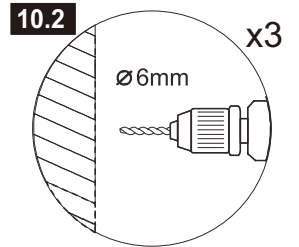
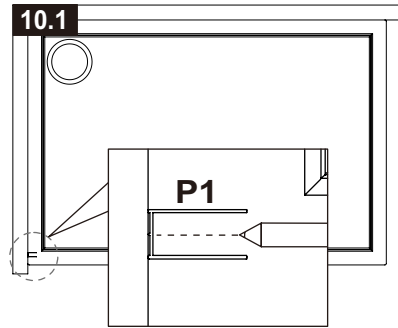
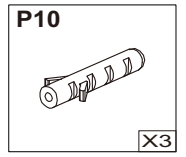
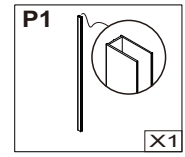
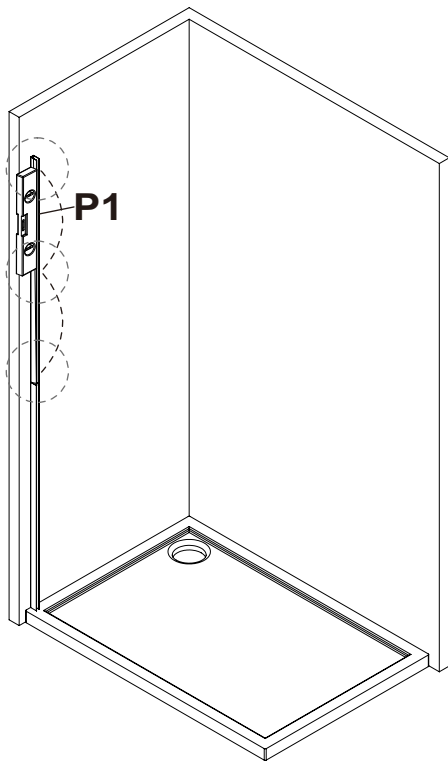

11

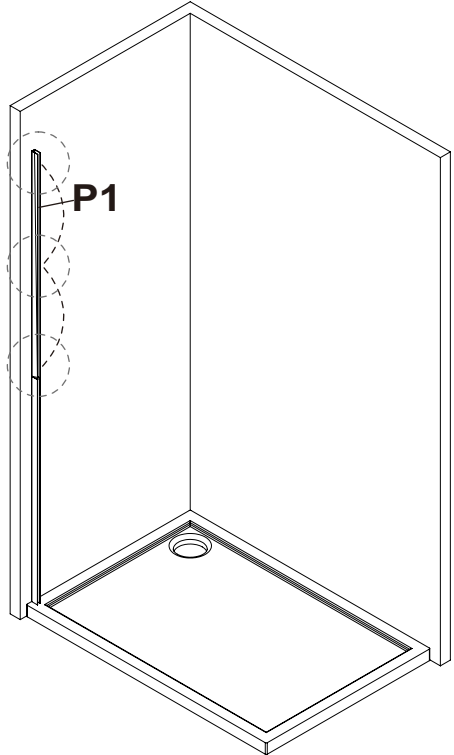
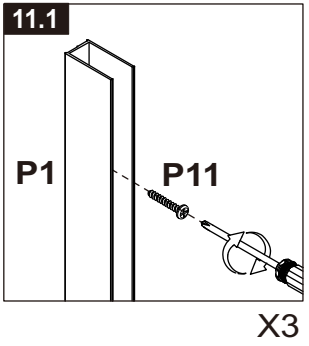

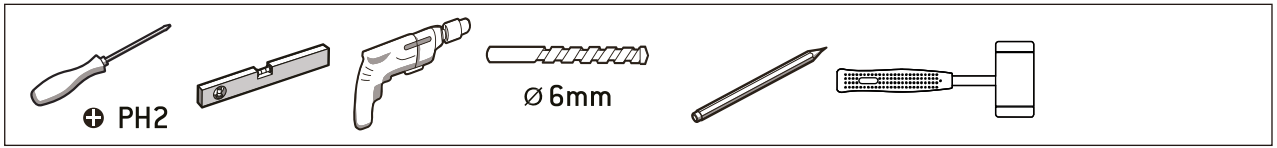

12

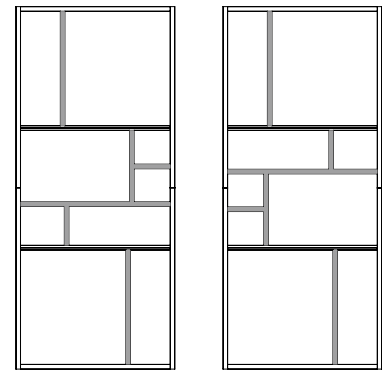
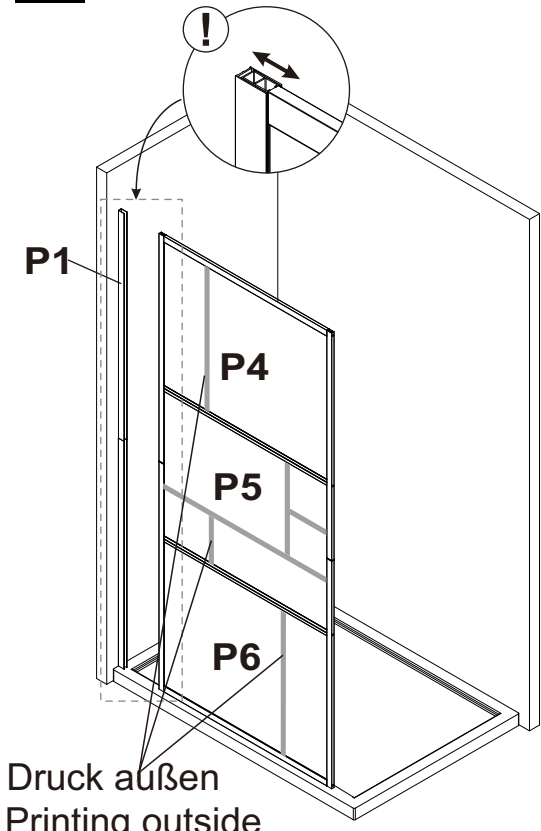

Reversibel
Reversible

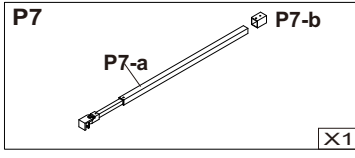
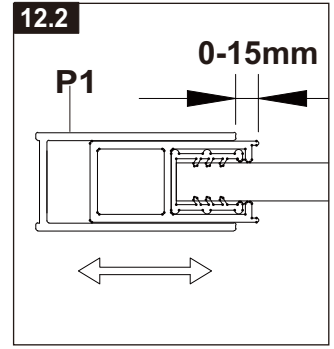
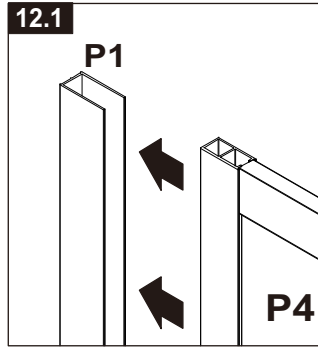
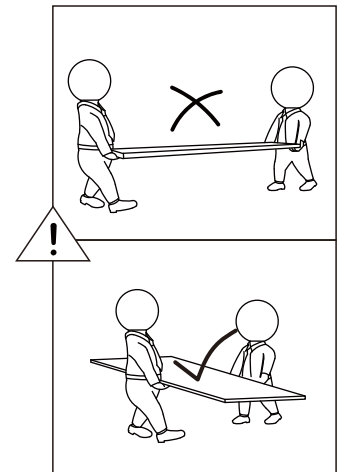

13

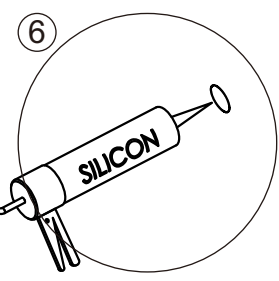
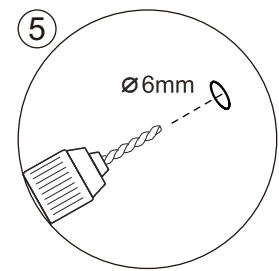
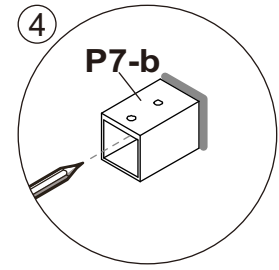
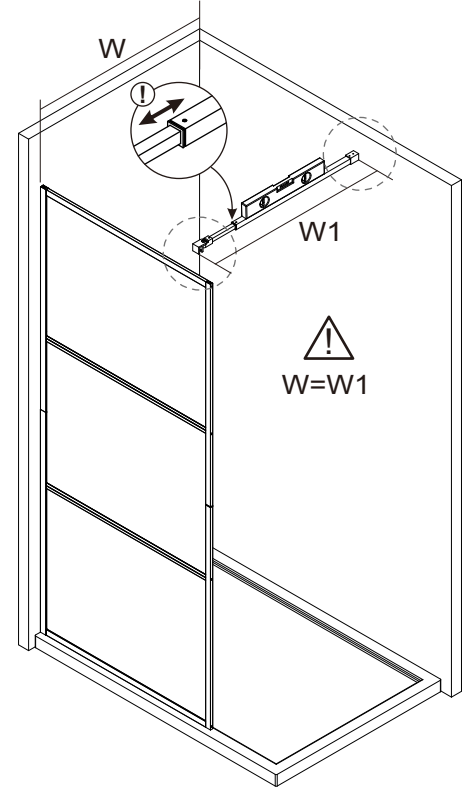
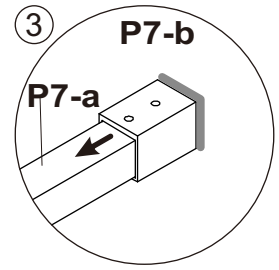
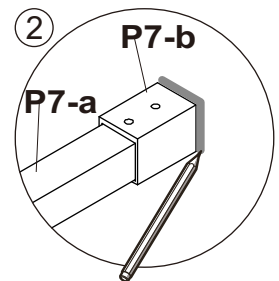
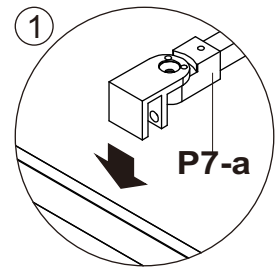



14

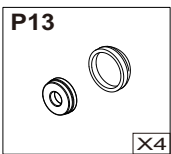
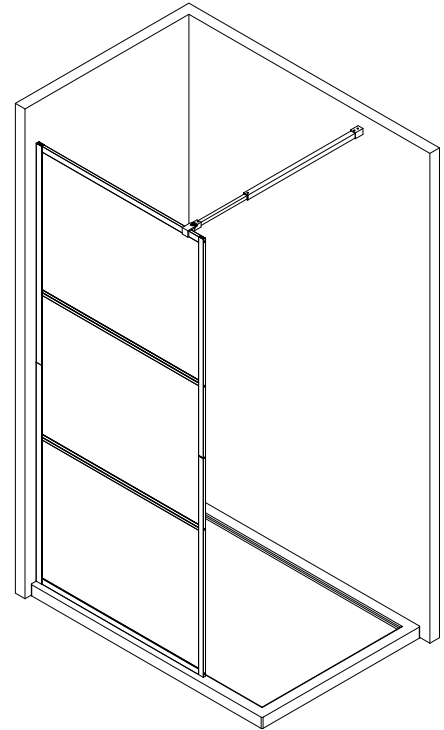
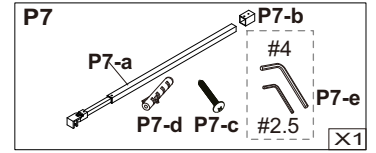
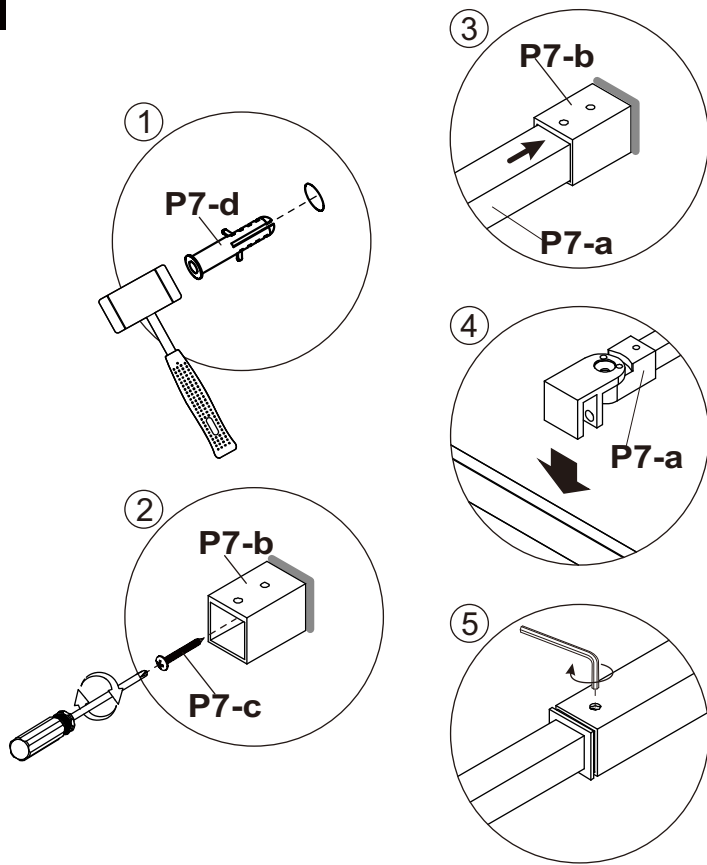

15

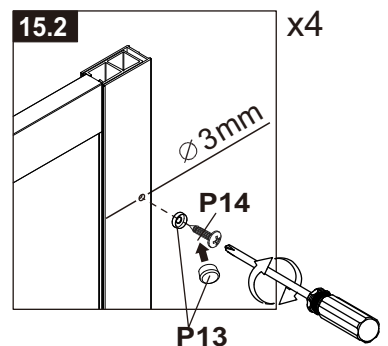
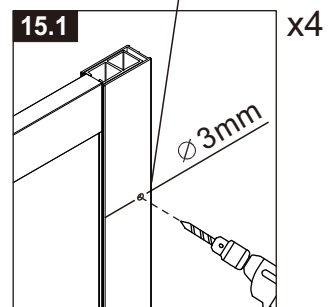
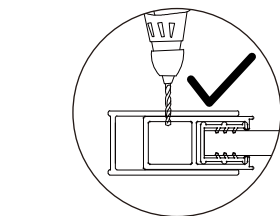
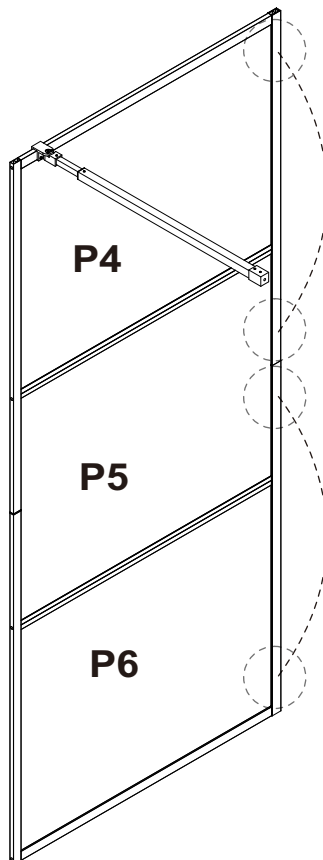
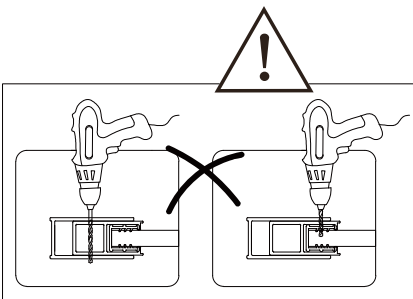
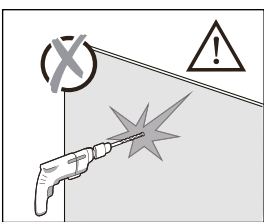

16



16

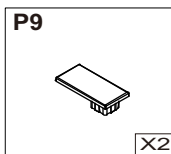
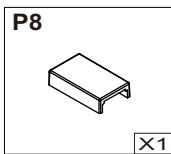
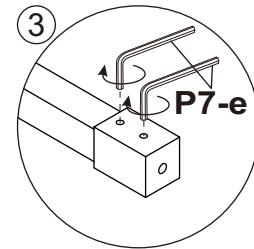
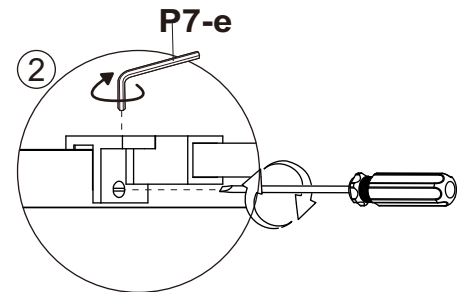
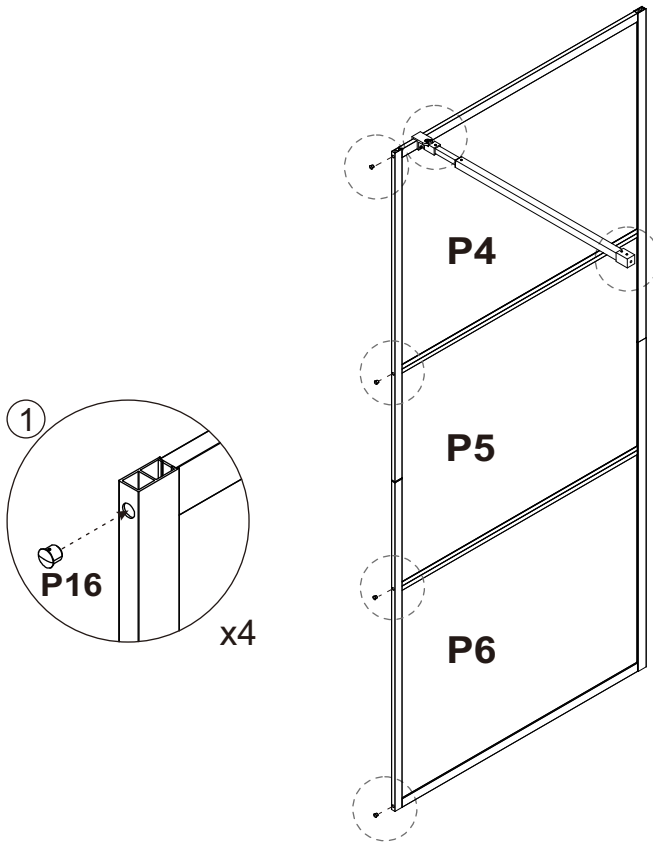
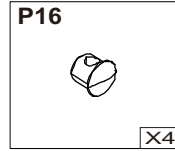
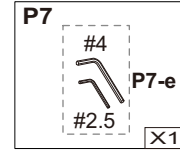

17

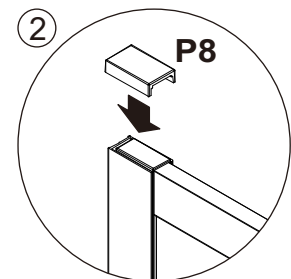
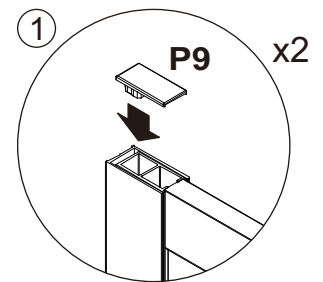
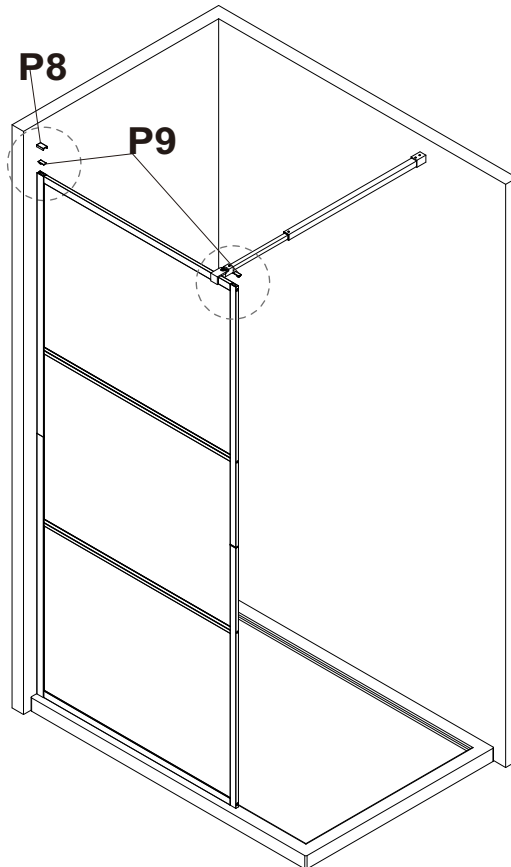



18

