

PLASTIC GARDEN SHED NANTES 6X6

Kunststoffgerätehaus Nantes 6x6

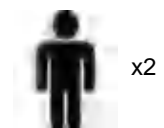

Art-No. 32888689
BAHAG AG
Gutenbergstr.21, 68167Mannheim, Germany
service@bauhaus.info



WARNING

Please read the instruction manual carefully before assembly.
Please assembly strictly in accordance with the instrution.
Please double - check to ensure that all parts of the package contents intact.
To avoid injury, work gloves are recommended during assembly.

ACHTUNG

Bitte lesen Sie die Aufbauanleitung sorgfältig vor der Montage.
Bitte halten Sie sich an die Anweisungen der Aufbauanleitung.
Bitte prüfen Sie vor dem Aufbau die Vollständigkeit der Teile.
Um Verletzungen zu vermeiden, tragen Sie bitte Sicherheitshandschuhe.

IMPORTANT SAFEGUARDS



Read these instructions carefully and retain them for future use. If this product is passed to a third party, then these instructions must be included.

When using the product, basic safety precautions should always be followed to reduce the risk of injury including the following:

⚠ WARNING - Risk of Injury!

- The product package contains small parts, sharp edges and sharp points. Keep children and pets away during assembly.
- Assemble on a dry and calm day. Do not attempt to assemble in strong wind or extreme weather.
- Take special precautions when working on heights, for example while using a ladder. Use the right type of ladder and ensure it is structurally sound. Use the ladder in accordance with the manufacturer's instructions.
- Use the drill driver properly and in accordance with the manufacturer's instructions.
- The product must be firmly anchored to a suitable base foundation to protect against injuries and damages caused by high winds.
- Intended use: The shed is suitable for storing garden tools and bicycles. The shed is not suitable for storing hazardous materials or for housing people or animals.

⚠ CAUTION - Risk of Injury!



Two competent people and at least 3 hours of work is required for the assembly.

⚠ CAUTION - Risk of Injury!



Sharp edges! Handle with care.



Wear eye protection.



Wear heavy duty protective gloves.



Wear safety footwear.



Wear protective clothing.

REQUIRED TOOLS

- Observe and follow all the local building ordinances. Apply for permission from local authorities if necessary. Always check with local authorities to ensure your shed is up to code.
- Do not let children climb on or play around the product.
- Always assemble the product on a firm, level ground.
- Do not use this product if any parts are missing, damaged, or worn.
- Do not over-tighten the fasteners.
- The roof covering may only be installed using a stable ladder. The roof may not be entered during assembly and for snow removal.

Before assembly

⚠ DANGER - Risk of Suffocation!

Keep any packaging materials away from children and pets – these materials are a potential source of danger, e.g. suffocation.

- The product is delivered in three cartons. For detailed information, please refer to "Parts List".
- Remove all the packing materials.
- Remove and review all components before starting assembly.
- Place all the components on a cloth or plastic sheet to avoid damage.
- To avoid scratches, lift large parts simultaneously with two people from both sides.
- Organize all the components according to the part numbers indicated on each component.
- Check all the components for transport damages.
- Prepare all the personal protective equipment (PPE) and all the tools required for assembly.

Selecting location

CAUTION

- The product must be anchored to a solid base foundation, such as concrete slab or paving slabs.
- Do not assemble the products on soft ground directly, such as lawn, soil or gravel. For a suitable concrete or paving slabs base foundation, contact an authorized local building dealer.

i Notice

- Select a location that allows sufficient working space around the product.
- Make sure the location is firm and level without roots or clumps of rocks.
- The base frame must lie flat on the ground. Level the base frame using a spirit level.
- Avoid locations with low hanging branches, as heavy branches could fall and damage the product.
- Avoid assembling the product in a low-lying area that collects water or that lies at the bottom of a hill.
- Small trees, bushes or fences around the product can be helpful to act as a windbreak.
- If concrete slab is used, it is important that it slopes towards the edges to prevent water collection.
- Plan in advance. If concrete slab is used, allow sufficient time for the concrete to dry before assembly.
- Be careful not to dig into the ground where water pipes, gas lines, or electrical cables are lying.
- Avoid placing the product anywhere near a septic tank, if present in the vicinity.
- If using a drill driver, set the torque to #4 to ensure the screws do not strip the metal reinforcements.

SITE PREPARATION

Level the ground surface

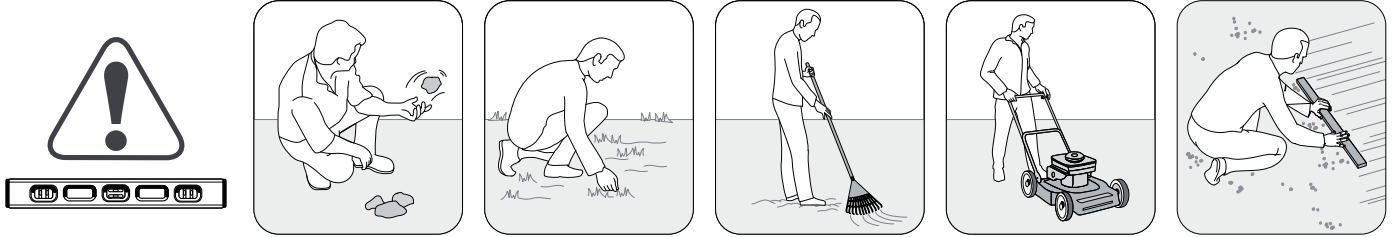

Recommendation:
Construct a paving slabs or concrete base as a foundation

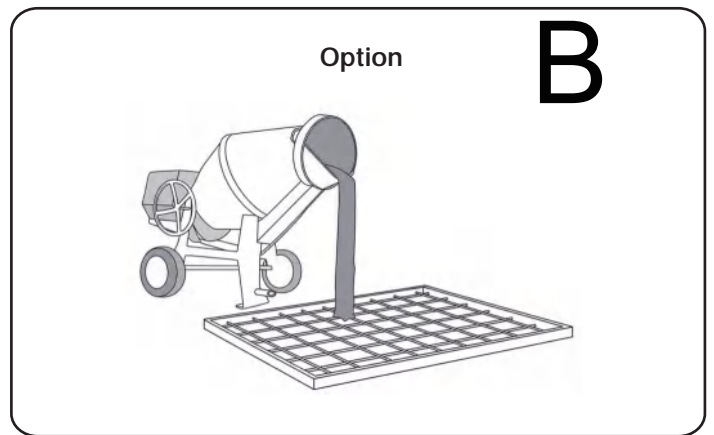
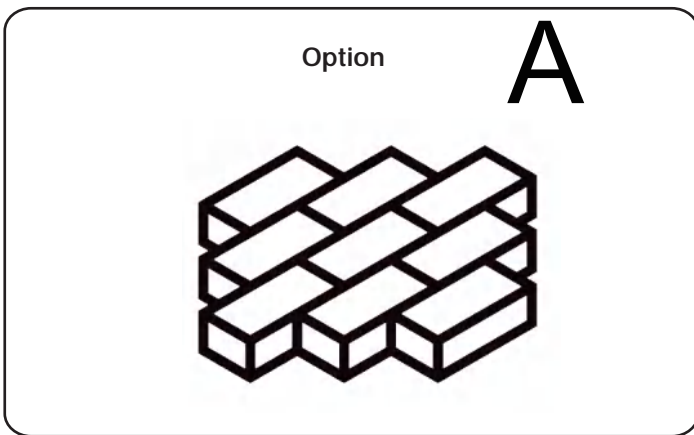

External floor measurements are:

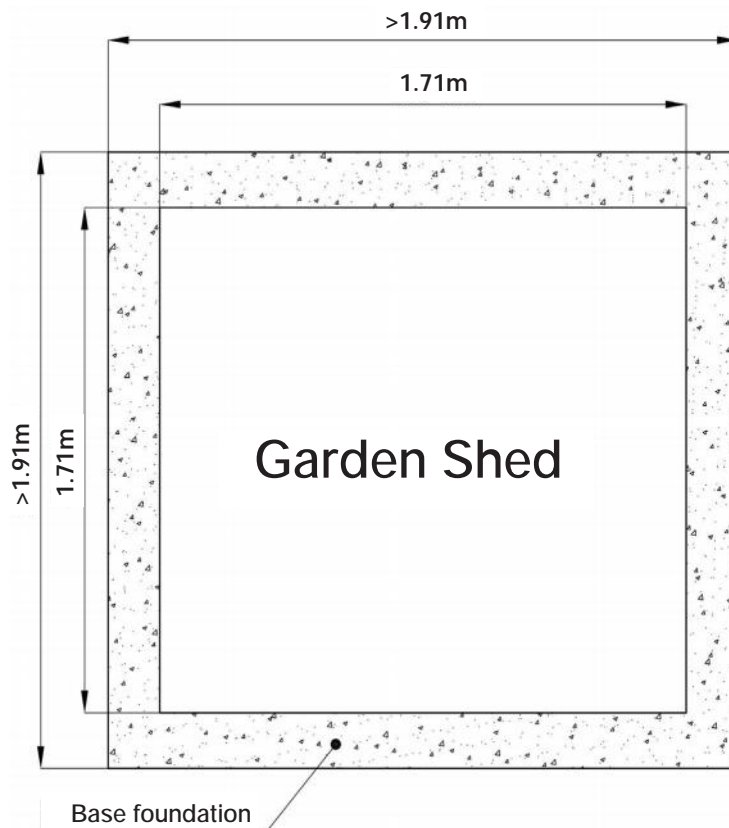

Assembly instructions

- Review all instructions before starting assembly.
- During assembly, carefully follow illustrated assembly steps and make sure you understand them fully. If in doubt, consult a professional builder.
- Plan in advance and book enough time for the assembly. Rushing often causes errors and could cause unnecessary injuries. If you have never assembled a shed before, take your time. Depending on your level of experience and the amount of help you have you might spend a bit more time on assembly.

Cleaning

Notice

Never use corrosive detergents, wire brushes, abrasive scourers, metal or sharp utensils to clean the product.

- Use a garden hose to rinse the shed siding.
- Scrub away the remaining dirt with a cloth, using mild detergent and water.
- Sweep out the shed interiors using a broom. A leaf blower can be used as well to blow away all the debris.
- To eliminate mildew, soak a cloth in mild detergent and scrub the mold and mildew away.
- To eliminate tree sap, pour some mild detergent over the sap and let it soak thoroughly before scrubbing hard.

Maintenance

- SHED: Regularly examine for wear and tear. Stop using at first sign of damage or if components become detached.
- ROOF: Keep clean of leaves and snow with long handled, soft bristled broom. Heavy snow or ice on the roof can damage the shed making it unsafe. Do not step on the roof. Do not use the roof as additional storage area. Check the roof regularly for any damages.
- WALLS: Do not rest any objects or lean against the wall panels.
- DOORS: Keep doors closed to prevent wind damage.
- Door rail: Applying lubricant on the door rail can make the door slide more smoothly.
- MOISTURE: With changing temperatures, condensation will accumulate inside the shed. Good ventilation will help in regulating and avoiding moisture. Open the door frequently to allow for proper ventilation.
- FASTENERS: Regularly check that all the components and fasteners are tightened.

Disposal



Dispose of the product according to local regulations.

Specifications

Net weight	approx. 78kg
Dimensions (D x W x H)	approx. 182x182 x219 cm

WICHTIGE SICHERHEITSVORKEHRUNGEN



Lesen Sie diese Anleitung sorgfältig durch und bewahren Sie sie für die zukünftige Verwendung auf. Wenn dieses Produkt an Dritte weitergegeben wird, müssen diese Anweisungen beigefügt werden. Bei der Verwendung des Produkts sollten immer grundlegende Sicherheitsvorkehrungen getroffen werden, um das Verletzungsrisiko zu verringern, einschließlich der folgenden:

⚠️ WARNUNG - Verletzungsgefahr!

- Die Produktverpackung enthält Kleinteile, scharfe Kanten und scharfe Spitzen. Kinder und Haustiere während der Montage fernhalten.
- Bei guten Wetterbedingungen zusammenbauen. Versuchen Sie nicht, bei starkem Wind oder extremem Wetter zu montieren.
- Treffen Sie besondere Vorsichtsmaßnahmen bei Arbeiten in der Höhe, z. B. bei der Benutzung einer Leiter. Verwenden Sie den richtigen Leitertyp. Verwenden Sie die Leiter gemäß den Anweisungen des Herstellers.
- Verwenden Sie den Bohrschrauber ordnungsgemäß und gemäß den Anweisungen des Herstellers.
- Das Produkt muss zum Schutz vor Verletzungen und Beschädigungen fest auf einem geeigneten Untergrund verankert sein.
- Verwendungszweck: Der Schuppen eignet sich zum Abstellen von Gartengeräten und Fahrrädern. Das Gartenhaus ist nicht geeignet für die Lagerung von Gefahrgütern oder für die Unterbringung von Menschen oder Tieren.

⚠️ WARNUNG - Verletzungsgefahr!



Zum Aufbau werden 2 Personen benötigt.

⚠️ WARNUNG - Verletzungsgefahr!



Scharfe Kanten! Mit Vorsicht behandeln.



Tragen Sie eine Schutzbrille.



Tragen Sie strapazierfähige Schutzhandschuhe.



Tragen Sie Sicherheitsschuhe.



Tragen Sie Schutzkleidung.

BENÖTIGTE WERKZEUGE

- Beachten und befolgen Sie alle örtlichen Bauvorschriften. Beantragen Sie bei Bedarf die Genehmigung der örtlichen Behörden. Erkundigen Sie sich immer bei den örtlichen Behörden, um sicherzustellen, dass Ihr Schuppen den Vorschriften entspricht.
- Lassen Sie Kinder nicht auf das Produkt klettern oder am das Produkt spielen.
- Montieren Sie das Produkt immer auf einem festen, ebenen Untergrund.
- Verwenden Sie dieses Produkt nicht, wenn Teile fehlen, beschädigt oder abgenutzt sind.
- Ziehen Sie die Befestigungselemente korrekt aber nicht zu fest an.
- Die Dacheindeckung darf nur mit einer stabilen Leiter montiert werden. Das Dach darf während der Montage und zur Schneeräumung nicht betreten werden.

Vor der Montage

⚠ GEFAHR - Erstickungsgefahr!

Halten Sie Verpackungsmaterialien von Kindern und Haustieren fern – diese Materialien stellen eine potenzielle Gefahrenquelle dar, z. B. Erstickungsgefahr.

- Das Produkt wird in einem Karton geliefert. Detaillierte Informationen finden Sie unter "Stückliste".
- Entfernen Sie alle Verpackungsmaterialien.
- Überprüfen Sie alle Komponenten, bevor Sie mit der Montage beginnen.
- Legen Sie alle Komponenten auf ein Tuch oder eine Plastikfolie, um Beschädigungen zu vermeiden.
- Um Kratzer zu vermeiden, heben Sie große Teile gleichzeitig mit zwei Personen von beiden Seiten an.
- Arrangieren Sie alle Komponenten gemäß den Teilenummern, die auf jeder Komponente angegeben sind.
- Überprüfen Sie alle Komponenten auf Transportschäden.
- Bereiten Sie die gesamte persönliche Schutzausrüstung (PSA) und alle für die Montage erforderlichen Werkzeuge vor.

Standort auswählen

VORSICHT

- Das Produkt muss auf einem soliden Untergrund, wie z. B. einer Betonplatte oder Gehwegplatten, verankert werden.
- Montieren Sie die Produkte nicht direkt auf weichem Untergrund wie Rasen, Erde oder Kies. Für ein geeignetes Fundament aus Beton oder Gehwegplatten wenden Sie sich an einen autorisierten Handwerker vor Ort.

i Anmerkung

- Wählen Sie einen Ort, der ausreichend Arbeitsraum um das Produkt herum ermöglicht.
- Stellen Sie sicher, dass der Standort fest und eben ist, ohne Wurzeln oder Steinklumpen.
- Das Untergestell muss flach auf dem Boden aufliegen. Nivellieren Sie den Grundrahmen mit einer Wasserwaage.
- Vermeiden Sie Standorte mit niedrig hängenden Ästen, da schwere Äste herunterfallen und das Produkt beschädigen könnten.
- Vermeiden Sie es, das Produkt in einem niedrig gelegenen Bereich zu montieren, in dem sich Wasser sammelt oder der am Fuße eines Hügels liegt.
- Kleine Bäume, Büsche oder Zäune rund um das Produkt können hilfreich sein, um als Windschutz zu dienen.
- Wenn Betonplatten verwendet werden, ist es wichtig, dass sie zu den Rändern hin geneigt sind, um Wasseransammlungen zu verhindern.
- Planen Sie im Voraus. Wenn eine Betonplatte verwendet werden soll, lassen Sie dem Beton vor der Montage genügend Zeit zum Trocknen.
- Achten Sie darauf, nicht in den Boden zu graben, wo Wasserleitungen, Gasleitungen oder elektrische Kabel verlaufen.
- Vermeiden Sie es, das Produkt in der Nähe einer Klärgrube zu platzieren, falls sich diese in der Nähe befindet.
- Wenn Sie einen Bohrschrauber verwenden, stellen Sie das Drehmoment auf #4 ein, um sicherzustellen, dass die Schrauben nicht überdreht werden.

VORBERREITUNG DES AUFSTELLUNGSRORTES

Ebnen Sie die Bodenoberfläche



Empfehlung: Verwenden sie als Fundament Gehwegplatten oder Beton.

option

A

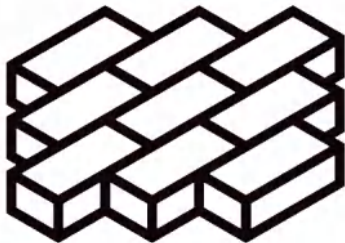

option

B

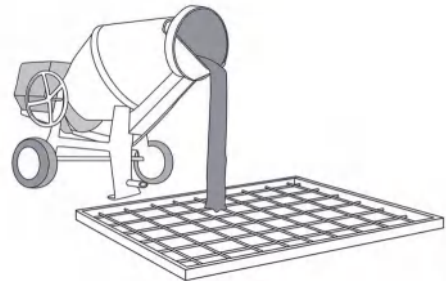

Die Außen- und Bodenmaße betragen:

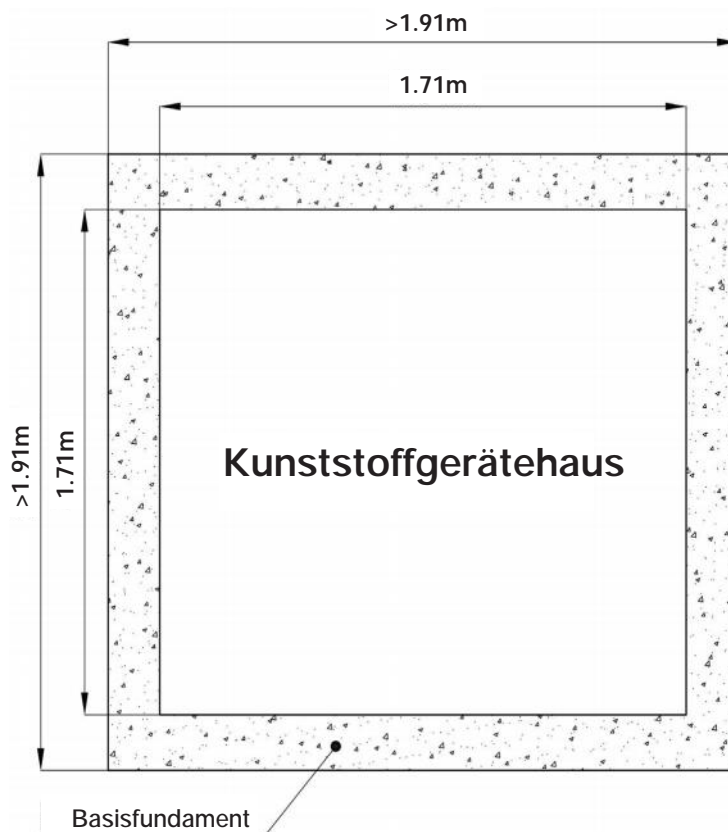

Montageanleitung

- Lesen Sie alle Anweisungen sorgfältig durch, bevor Sie mit der Montage beginnen.
- Befolgen Sie beim Aufbau sorgfältig die abgebildeten Schritte und stellen Sie sicher, dass Sie diese vollständig verstanden haben. Wenden Sie sich im Zweifelsfall an einen professionellen Handwerker.
- Planen Sie im Voraus und nehmen Sie sich genügend Zeit für den Aufbau. Eile führt oft zu Fehlern und kann zu unnötigen Verletzungen führen. Wenn Sie noch nie einen Gartenschuppen aufgebaut haben, lassen Sie sich Zeit. Je nach Erfahrung und Unterstützung kann der Aufbau etwas länger dauern.

Reinigung

Achtung

Verwenden Sie niemals ätzende Reinigungsmittel, Drahtbürsten, Scheuerschwämme, Metall oder scharfe Utensilien, um das Produkt zu reinigen.

- Verwenden Sie einen Gartenschlauch, um die Seiten des Schuppens abzusprühen.
- Schrubben Sie den restlichen Schmutz mit einem Tuch mit einem milden Reinigungsmittel und Wasser ab.
- Fegen Sie die Innenräume des Schuppens mit einem Besen aus. Ein Laubbläser kann auch verwendet werden, um alle Ablagerungen wegzublasen.
- Um Schimmel zu beseitigen, tränken Sie ein Tuch in mildem Reinigungsmittel und schrubben Sie den Schimmel und Mehltau weg.
- Um Baumsaft zu entfernen, gießen Sie etwas mildes Reinigungsmittel über den Saft und lassen Sie ihn gründlich einweichen, bevor Sie ihn kräftig schrubben.

Instandhaltung

- **SCHUPPEN:** Regelmäßig auf Verschleiß untersuchen. Beenden Sie die Verwendung beim ersten Anzeichen einer Beschädigung oder wenn sich Teile der Konstruktion lösen.
- **DACH:** Mit einem langstieligen Besen und weichen Borsten das Dach von Laub und Schnee befreien. Starker Schnee oder Eis auf dem Dach kann den Schuppen beschädigen und das Dach beeinträchtigen. Treten Sie nicht auf das Dach. Verwenden Sie das Dach nicht als zusätzlichen Stauraum. Überprüfen Sie das Dach regelmäßig auf Beschädigungen.
- **WÄNDE:** Lehnen Sie keine Gegenstände an die Wandpaneele.
- **TÜREN:** Halten Sie die Türen geschlossen, um Windschäden zu vermeiden.
- **FEUCHTIGKEIT:** Bei wechselnden Temperaturen kann sich Kondenswasser im Schuppen ansammeln. Eine gute Belüftung hilft bei der Regulierung und Vermeidung von Feuchtigkeit. Öffnen Sie die Tür häufig, um eine ausreichende Belüftung zu ermöglichen.
- **BEFESTIGUNGEN:** Überprüfen Sie regelmäßig, ob alle Komponenten und Befestigungselemente festgezogen sind.

Entsorgung















Entsorgen Sie das Produkt gemäß den örtlichen Vorschriften.

Technische Daten



Artikelinformation	Ca. 78kg
Maße	Ca. 182x182 x219 cm

Part List / Teileliste

No./Nr.	Part/Teil	Qty./Menge	No./Nr.	Part/Teil	Qty./Menge	No./Nr.	Part/Teil	Qty./Menge
PF1-1		4	DA1R		1	DD1-5		1
PF1-2		2	DA1L		1	DD1-6		1
DP2		3	DA3		1	DS1		2
DP3		2	PS6-B		1	DA4		2
DP4		1	PS5		2	DA2R		1
SG6		4	PS11		1	DA2L		1
SG7-2		1	PR3-2		4	DA2		1
SG7-1		1	PR3-3		2	DA1		1
PP4		1	PP1		2	SG9		5
CW2-1		14	PP3		4	BY		2
DW1-1		2	PP11		4	M01		4
PW1-3		1	PS7		1	M03-6L		1
PW1-5		1	CS4-1		2	M03-7		1
DW5-1		6	CS2-5		4	M04		1
DW3-4		1	SG1		2	SG8		2
DW3-3		1	SG2		4	SG14		4
DP5		4	SG10		1	BJ-1		1
PPA1		2	SG101		1	DC		2
PS1		2	SG102		1	PS3		1
PPA2		1	DD1-2		1	DD1-4		1
CPA1		1	DD1-1		1			
PS4		1	DD1-3		1			

No./Nr.	Part/Teil	Qty./Menge	Size/Größe	No./Nr.	Part/Teil	Qty./Menge	Size/Größe
Z410		144	4x10mm	Drill		1	Dia:3mm
Z420		110	4x20mm	ZW413		46	4x13mm
Z425		4	4x25mm	PZG4X8		4	M6x100mm



- Use spatula  (part"SG8") for easier insertion of panel into profile.
- Please ensure the panels are all installed on position before screwing.
- Please be mindful of the screw size used during installation.
- Using screws that are too long may damage the shed.
- Benutzen Sie das Werkzeug  "SG8" für ein leichteres Gleiten der Panele in die Profile.
- Bitte achten Sie darauf, dass die Panele korrekt in Position sind, bevor Sie diese fest verschrauben.
- Bitte achten Sie auf die Nutzung der korrekten Schrauben.
- Zu lange Schrauben können Schäden beim Aufbau verursachen.

Parts Schematic / Teile Übersicht

Roof Parts /Dach

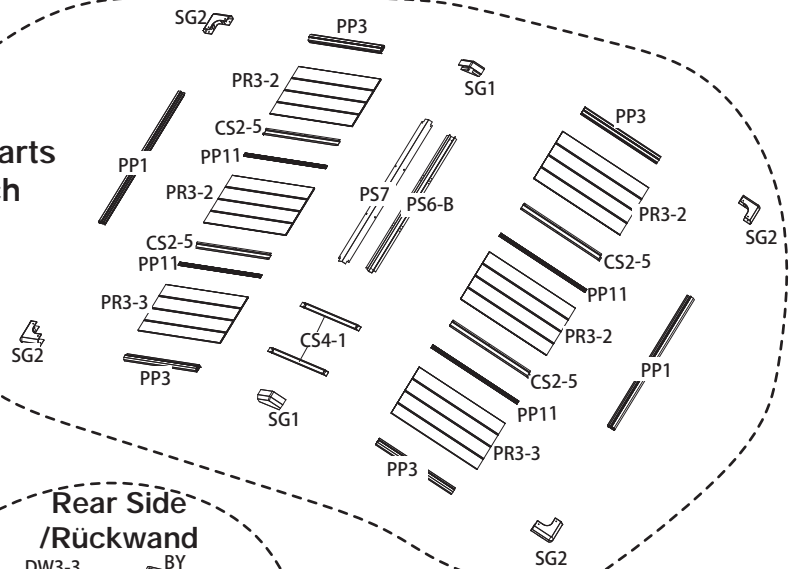

Left /Linke Wand

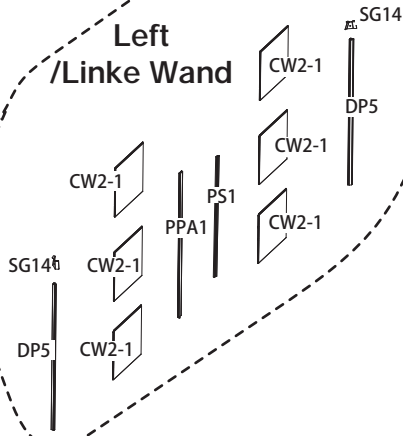

Rear Side /Rückwand

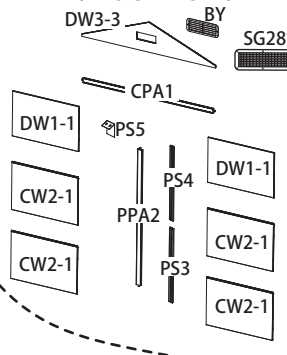

Right /Rechte Wand

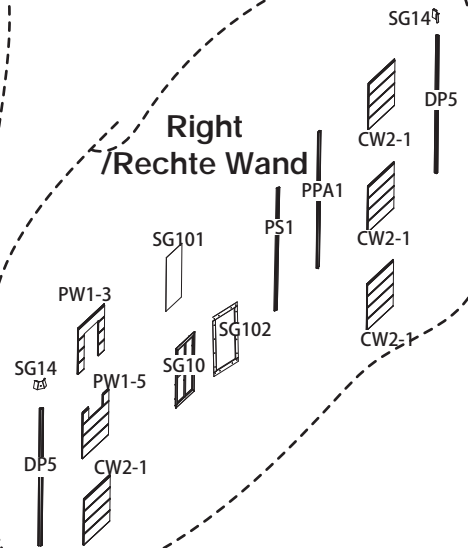

Front and door parts /Vorderseite

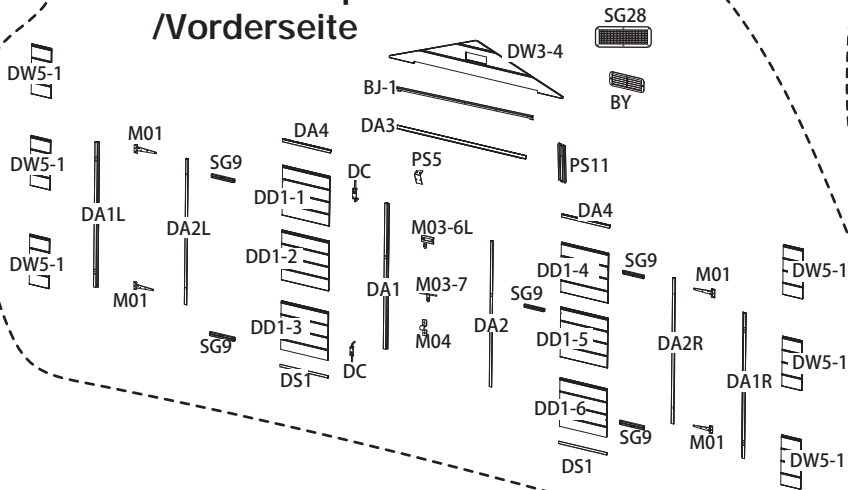

Floor Parts /Boden

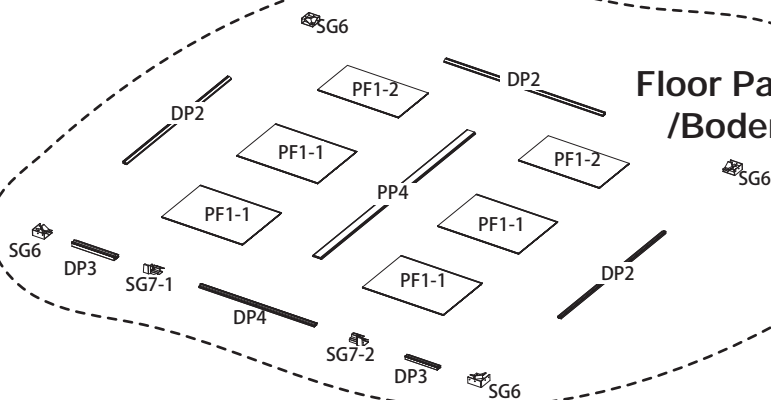

Floor Assembly /Bodenmontage



- Use spatula (part "SG8") for easier insertion of panel into profile.
- Benutzen Sie das Werkzeug "SG8" für ein leichteres Gleiten der Panele in die Profile.

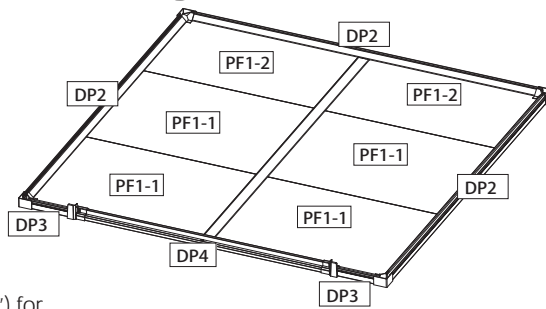

- After the floor is installed, it should be laid out neatly.
- Wenn der Boden fertig montiert ist, muss dieser glatt ausliegen.

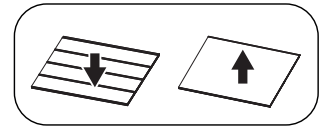

- The side of the floor with the grain should face down.
- Die glatte Seite zeigt nach oben

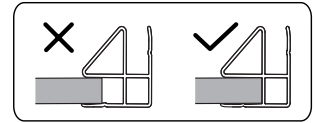

- The plates and sections should be in close contact.
- Die Panele müssen komplett im Profil liegen.

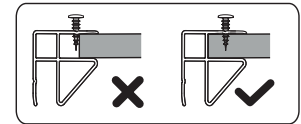

- The screws are to connect the sheet metal and the profile together.
- Die Schrauben dienen der Fixierung von Panel und Profil.

01



- In this step, place the flooring with the grain surface facing up.
- Für diesen Schritt muss die gestreifte Seite nach oben zeigen.

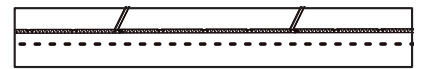

- After the floor is installed, it should be laid out neatly.
- Wenn der Boden fertig montiert ist, muss dieser glatt ausliegen.

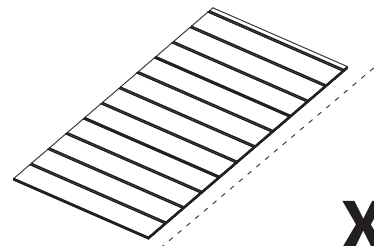
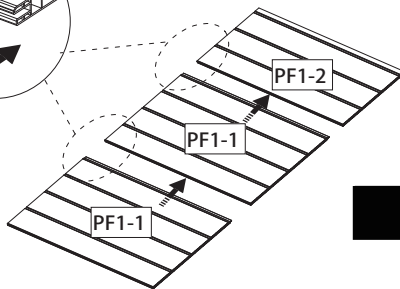
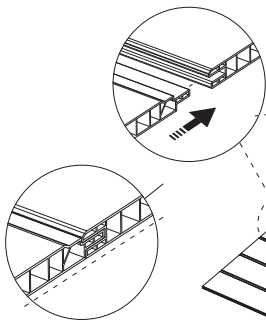

x 2

PF1-2		2 PC
PF1-1		4 PC
Z410		8 PC

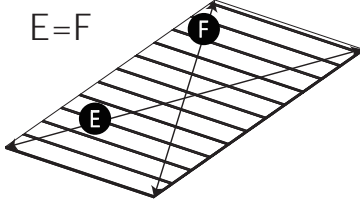

- Measure the diagonal of the assembled board E=F.
- Vor der Montage soll E=F in der Länge entsprechen.

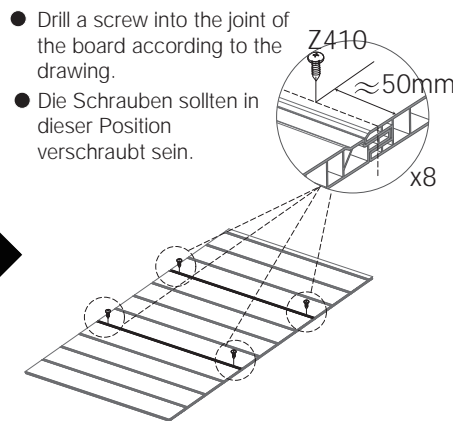

- Drill a screw into the joint of the board according to the drawing.
- Die Schrauben sollten in dieser Position verschraubt sein.

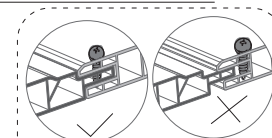





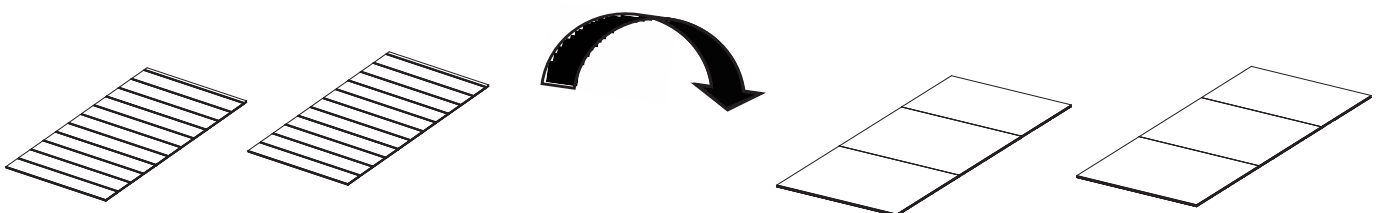

- Pay attention to the position of the screw.
- Achten Sie auf die korrekte Bohrung der Schraube.

x 2

- Please flip the two groups of flooring that have already been assembled 180°, with the grain facing down.
- Bitte drehen Sie beide Panele nach der Verschraubung, damit die glatte Seite nach oben zeigt.



DP2  3 PC	DP3  2 PC	DP4  1 PC	PP4  1 PC	SG7-1  1 PC	SG7-2  1 PC	SG6  4 PC	Z410 4 PC
---	---	---	---	---	---	---	-------------------------

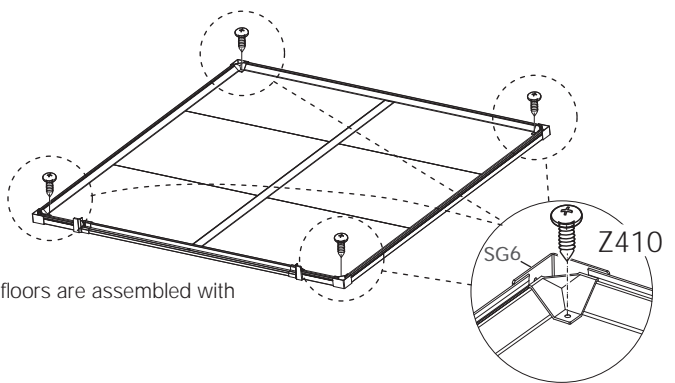
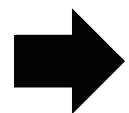
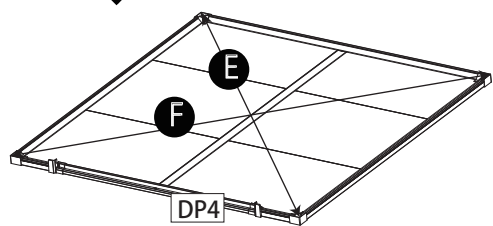
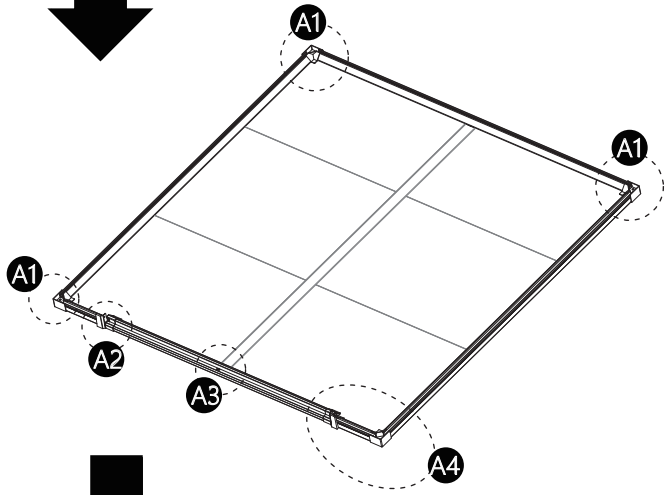
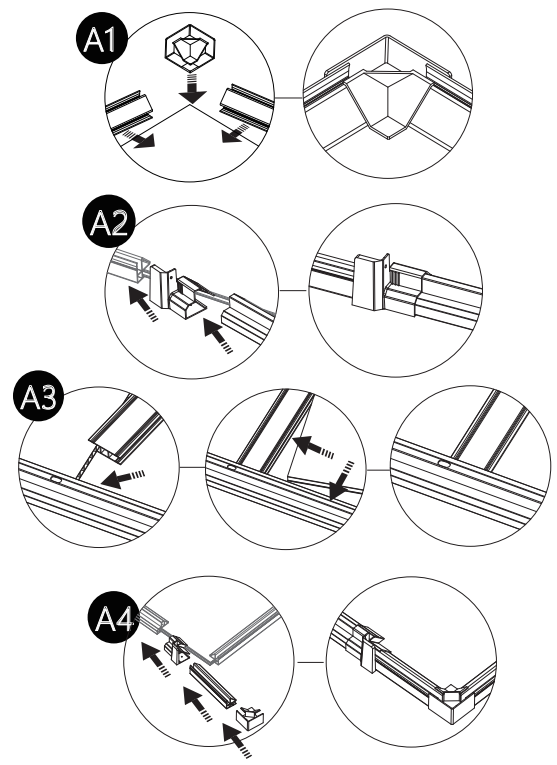
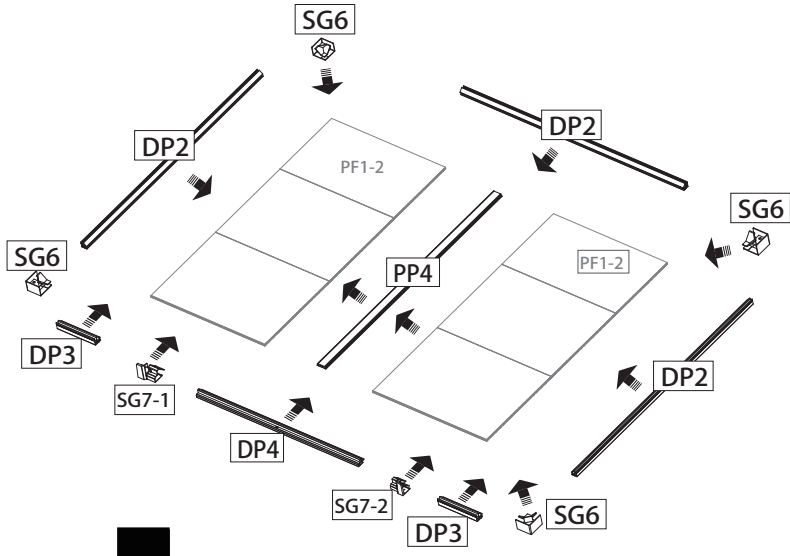

- please make measurement of the dimension of EF to make sure of all of floors are assembled with profiles well.
- Vor der Montage soll E=F in der Länge entsprechen.

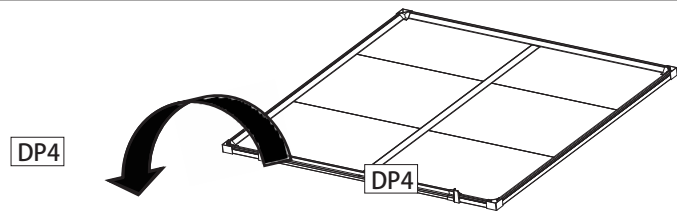

- To prevent it from spreading out, you need to flip the board inward with force, with the grain facing upwards.
- Für das Eindrehen der Schrauben muss der Boden gedreht werden, dabei genug Druck ausüben, damit die Teile nicht aus dem Rahmen rutschen.

Z420

- Drive the nails according to the marking lines on the profile.
- Die Schrauben wie unten gezeigt befestigen.

Caution:
Please use 3mm Drill to predrill a hole at depth 1mm before screw.

Achtung: Bitte verwenden Sie einen 3-mm-Bohrer, um ein Loch in einer Tiefe von 1 mm vorzubohren, bevor Sie die Schraube einsetzen.

Z410
4 PC

Z420
22 PC

PP4

- Flip the floor over so that the patterned surface is facing down.
- Nach der Montage den Boden drehen, damit die glatte Seite nach oben zeigt.

Wall panel assembly Wandpanelmontage

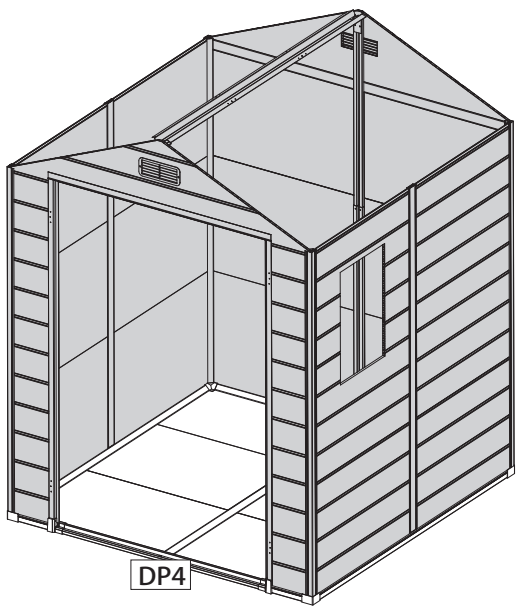

UP/Oben

Down/Unten

- Please pay attention to the installation direction of the wall panels.
- Bitte achten Sie auf die korrekte Richtung der Panele.

- The patterns on the exterior wall panels are aligned.
- Die Fugen der Panele sollten immer in einer Linie sein.

- The plates and sections should be in close contact.
- Die Panele müssen komplett im Profil liegen.

- The inclined insertion of the wall panel into the profile will make the installation smoother.
- Durch das Schräge einführen der Panele wird der Zusammenbau erleichtert.





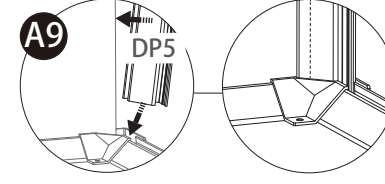
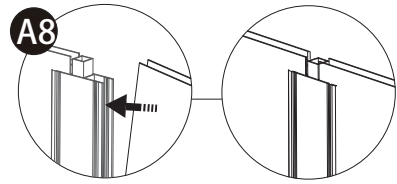
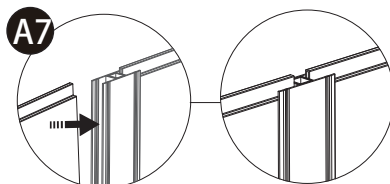
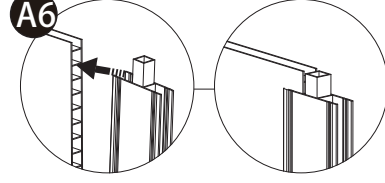
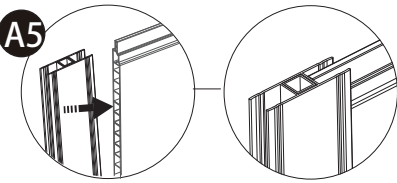
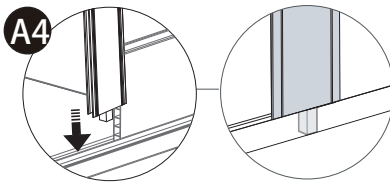
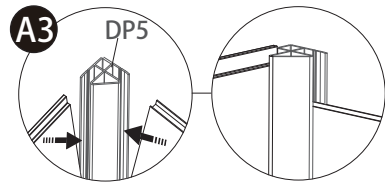
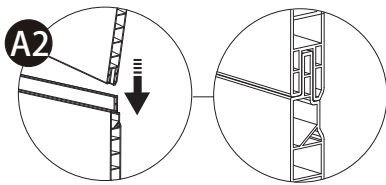
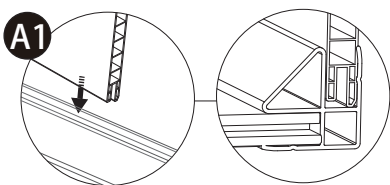
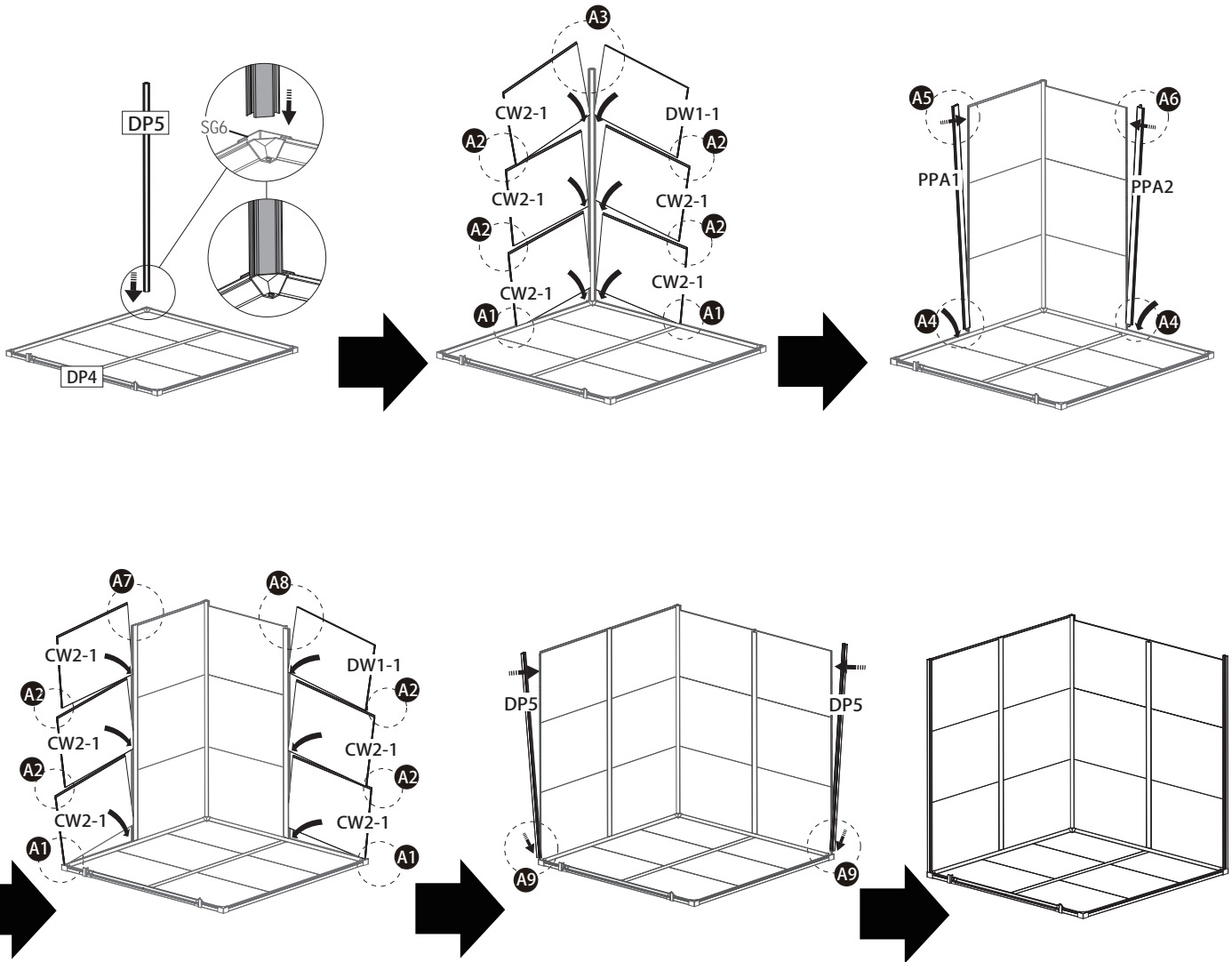

During the installation process, you can use SG8 to make the installation process easier.

Verwenden Sie das Werkzeug SG8, um die Panele leichter in die Profile zu bringen.





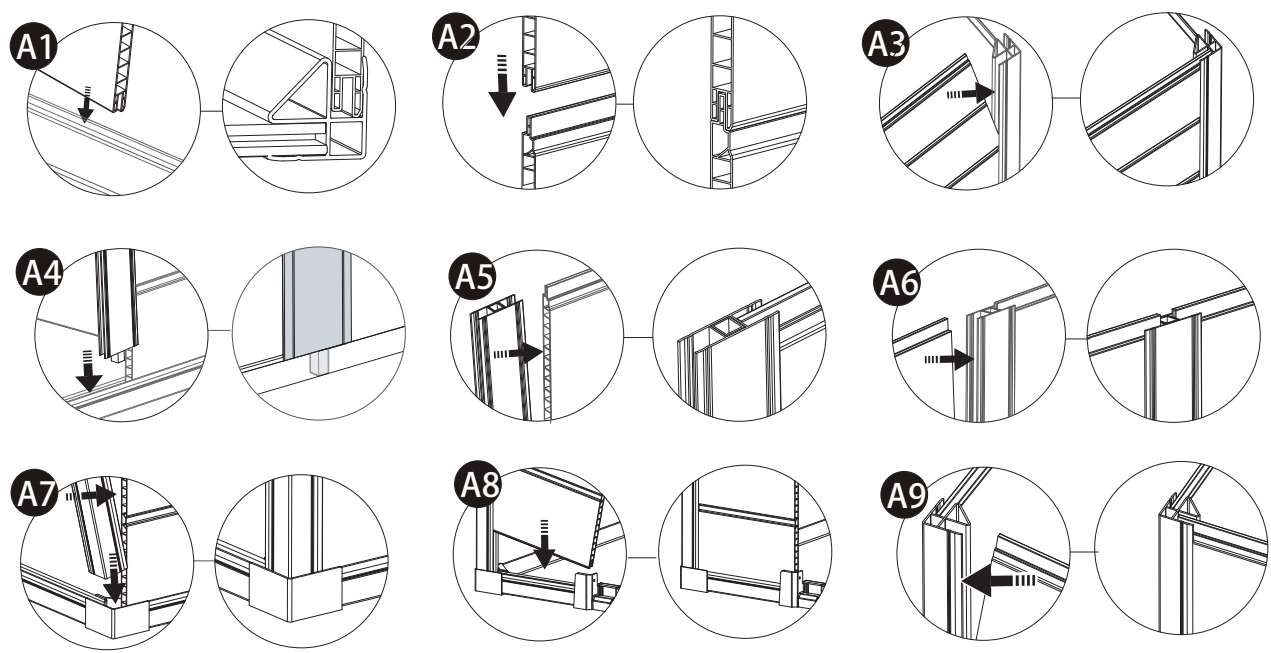
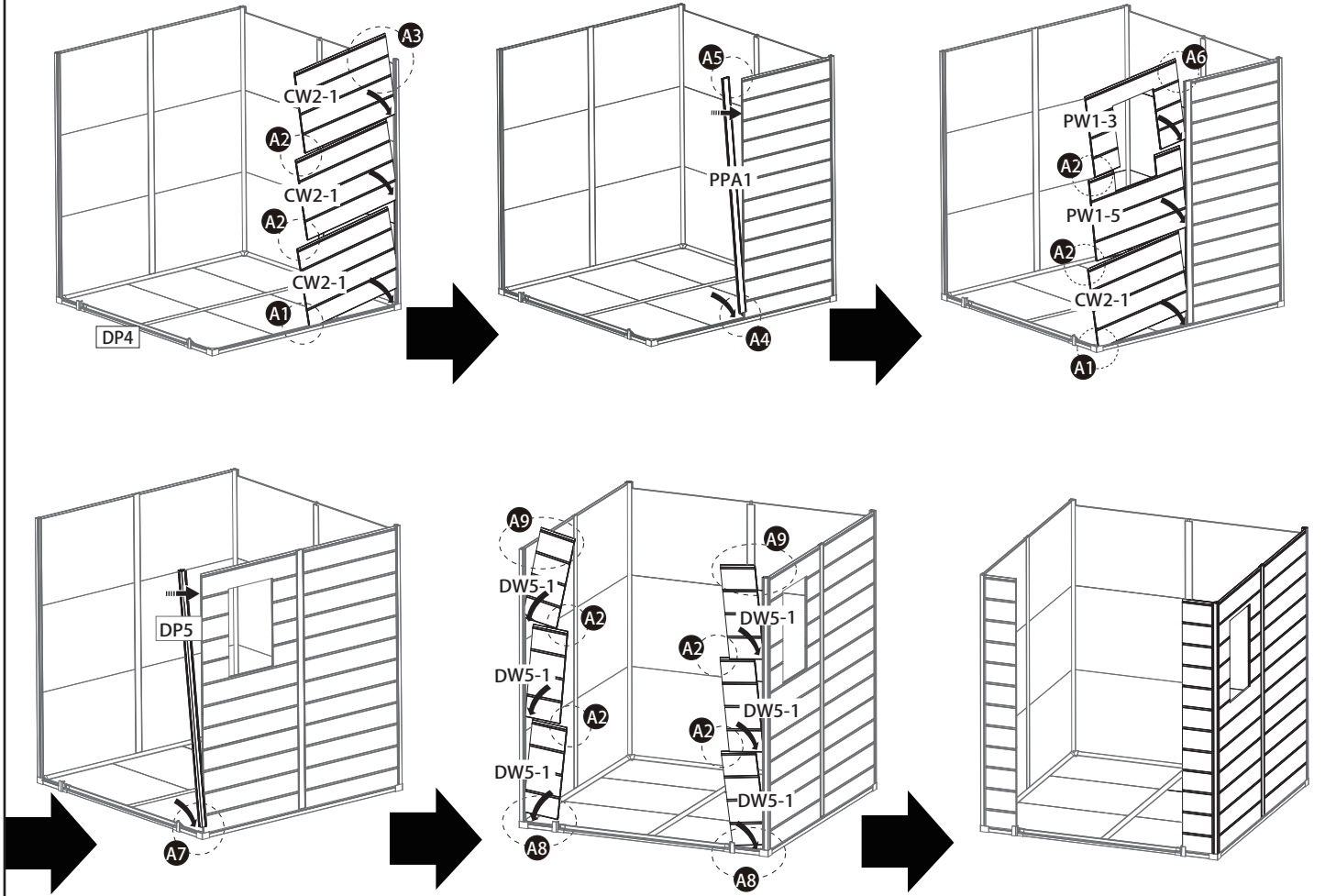

- The plates and the plates that are connected by insertion should remain in a parallel position.
- Die Panele sollen einen glatten Abschluss haben, wenn Nut und Feder ineinanderliegen.

CW2-1 10 PC	DW1-1 2 PC	DP5 3 PC	PPA1 1 PC	PPA2 1 PC
---------------------------	--------------------------	------------------------	-------------------------	-------------------------



CW2-1  4 PC	PPA1  1 PC	PW1-5  1 PC	PW1-3  1 PC	DP5  1 PC	DW5-1  6 PC
---	--	---	---	---	---





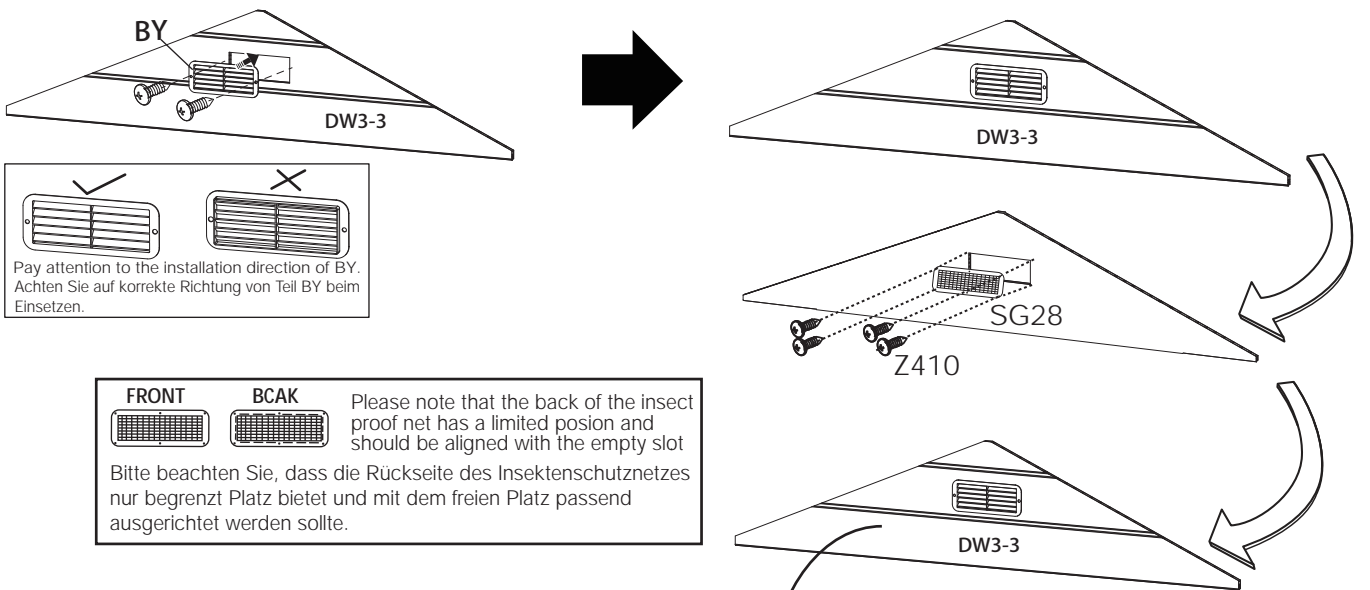
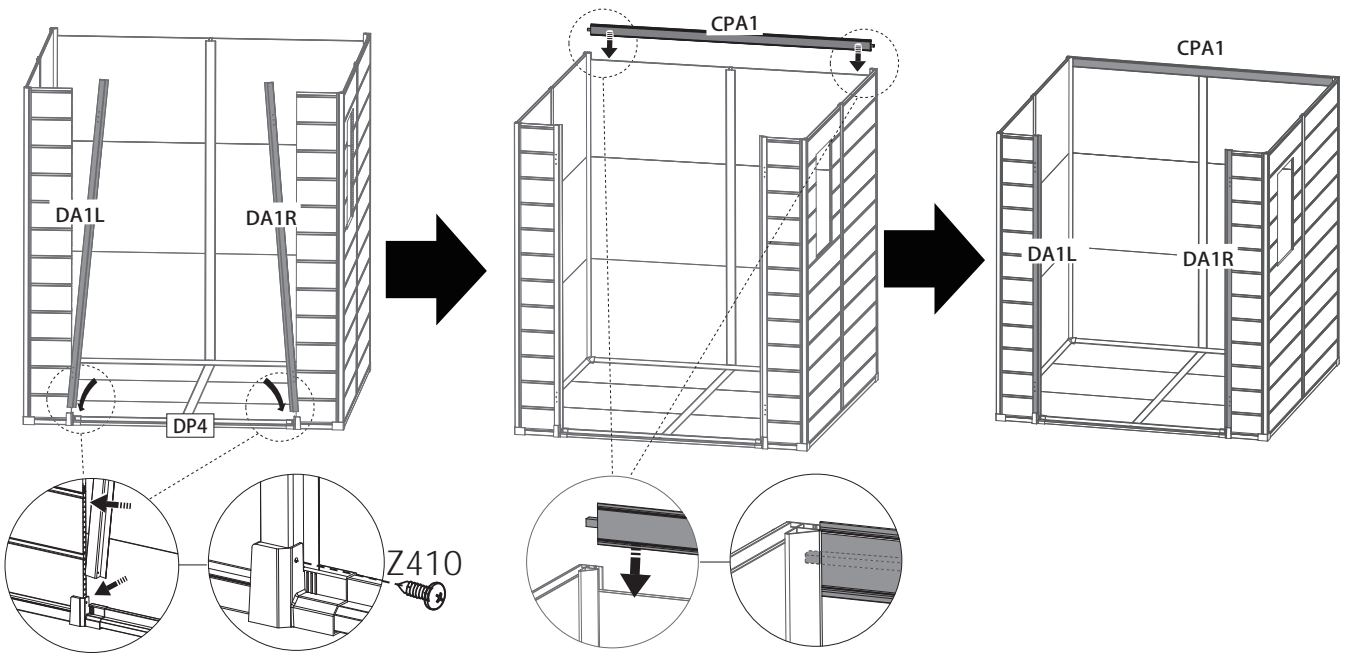

DA1L  1 PC	DA1R  1 PC	CPA1  1 PC	Z410  8 PC	DW3-3  1 PC	BY  1 PC	SG28  1 PC
--	--	--	--	---	--	--

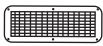
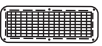

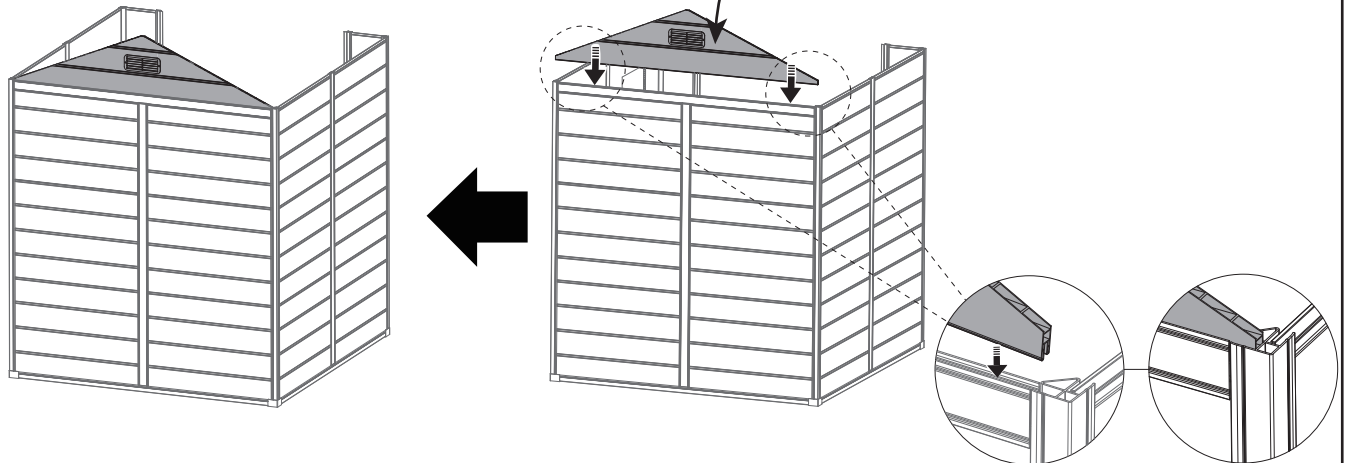
 ✓
 ✗
 Pay attention to the installation direction of BY.
 Achten Sie auf korrekte Richtung von Teil BY beim Einsetzen.

FRONT  **BACK** 
 Please note that the back of the insect proof net has a limited position and should be aligned with the empty slot
 Bitte beachten Sie, dass die Rückseite des Insektenschutznetzes nur begrenzt Platz bietet und mit dem freien Platz passend ausgerichtet werden sollte.

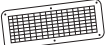

DW3-4  1 PC	BY  1 PC	DA3  1 PC	Z410  6 PC	SG28  1 PC
---	--	---	--	--

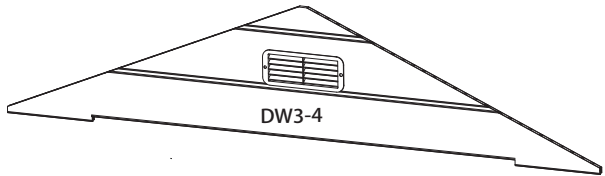
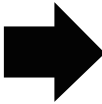
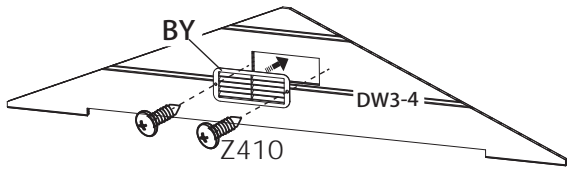

FRONT **BCAK** Please note that the back of the insect proof net has a limited position and should be aligned with the empty slot

Bitte beachten Sie, dass die Rückseite des Insektenschutznetzes nur begrenzt Platz bietet und mit dem freien Platz passend ausgerichtet werden sollte.

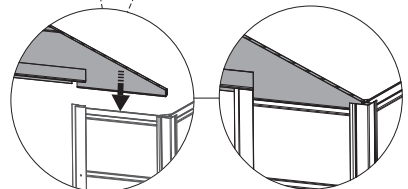
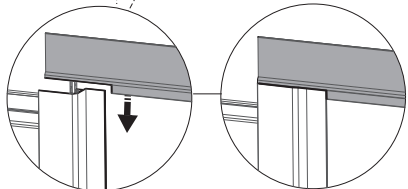
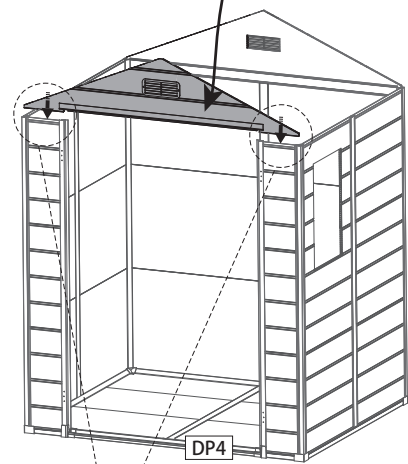
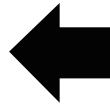
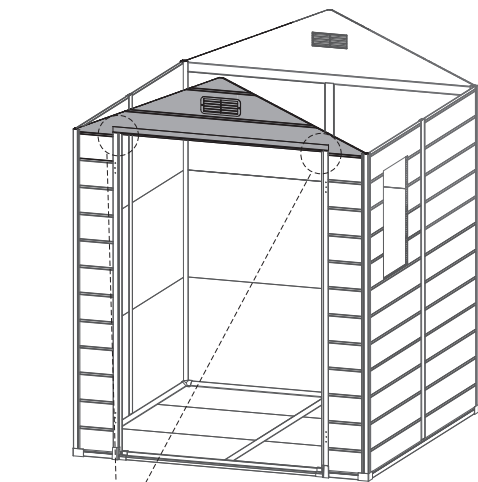
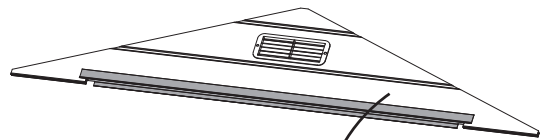
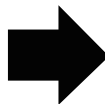
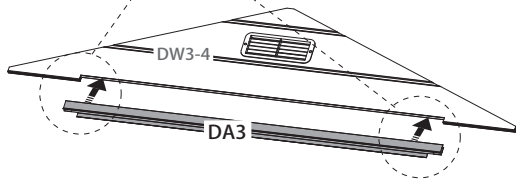
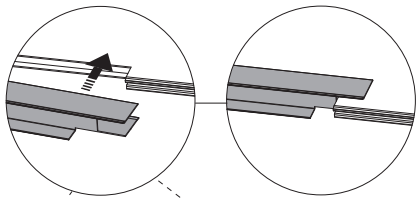
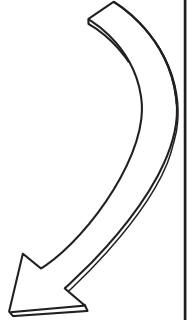
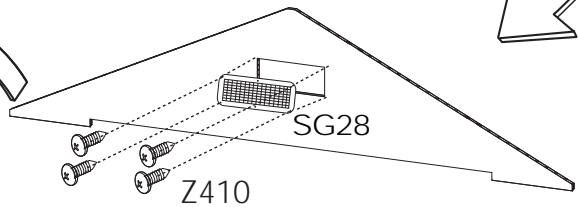
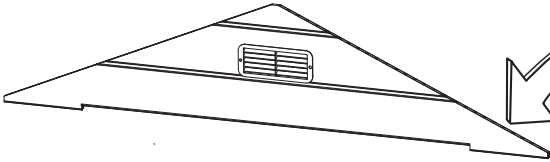

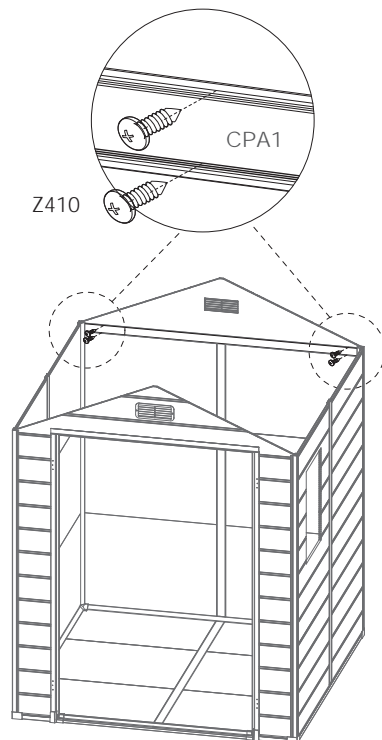
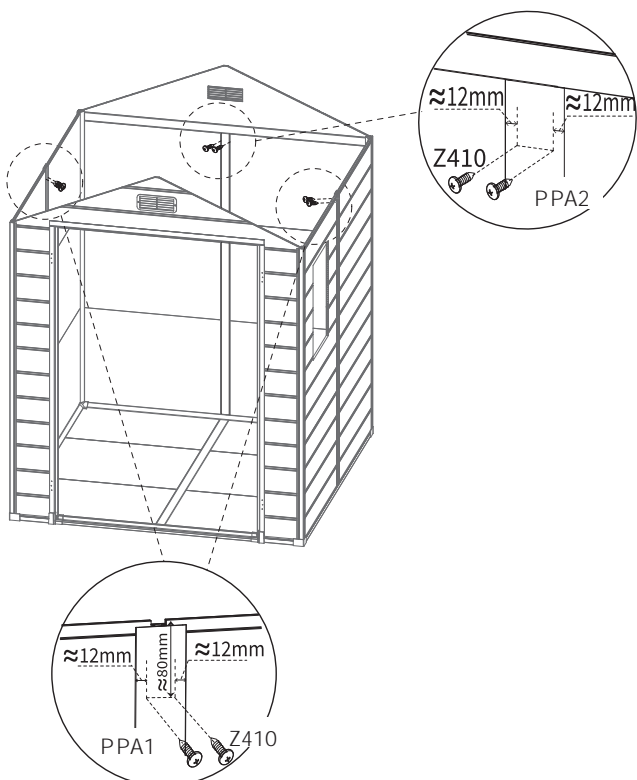
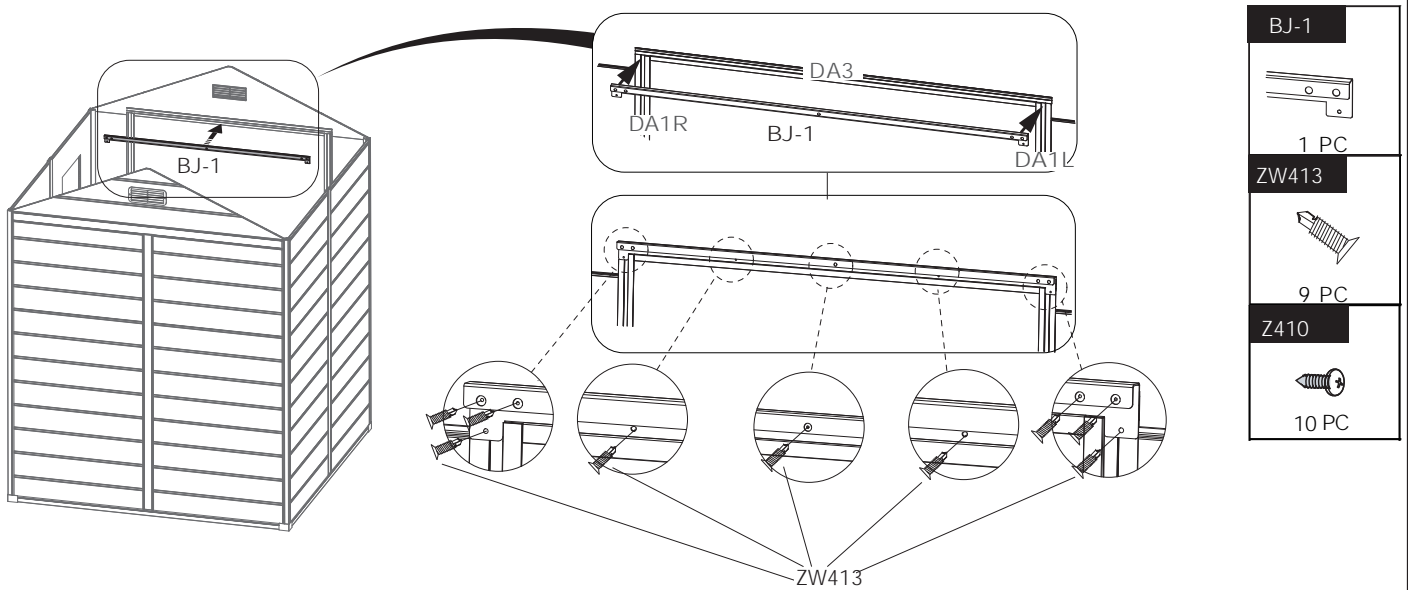
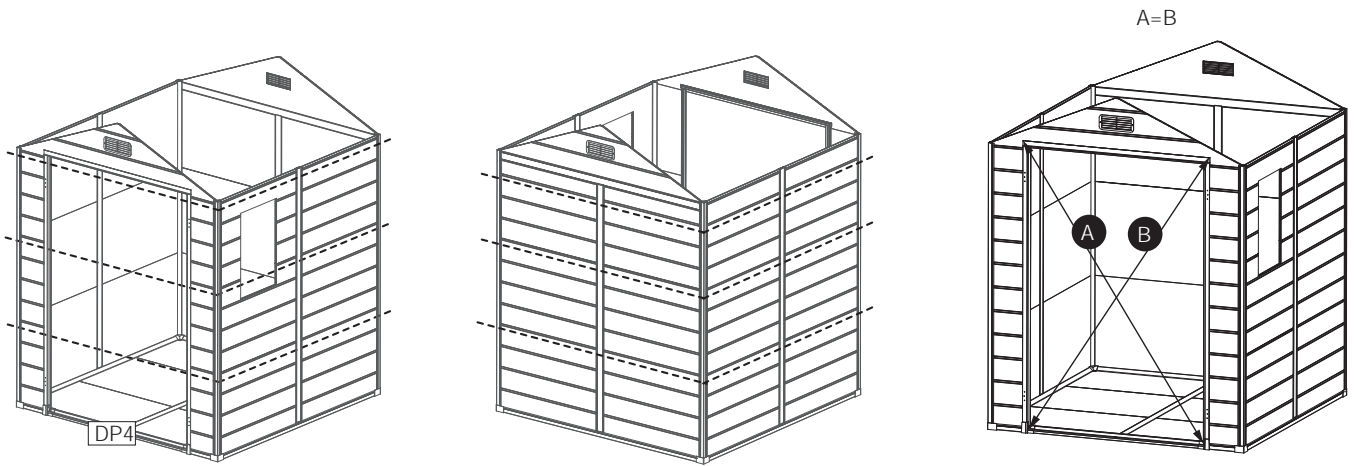

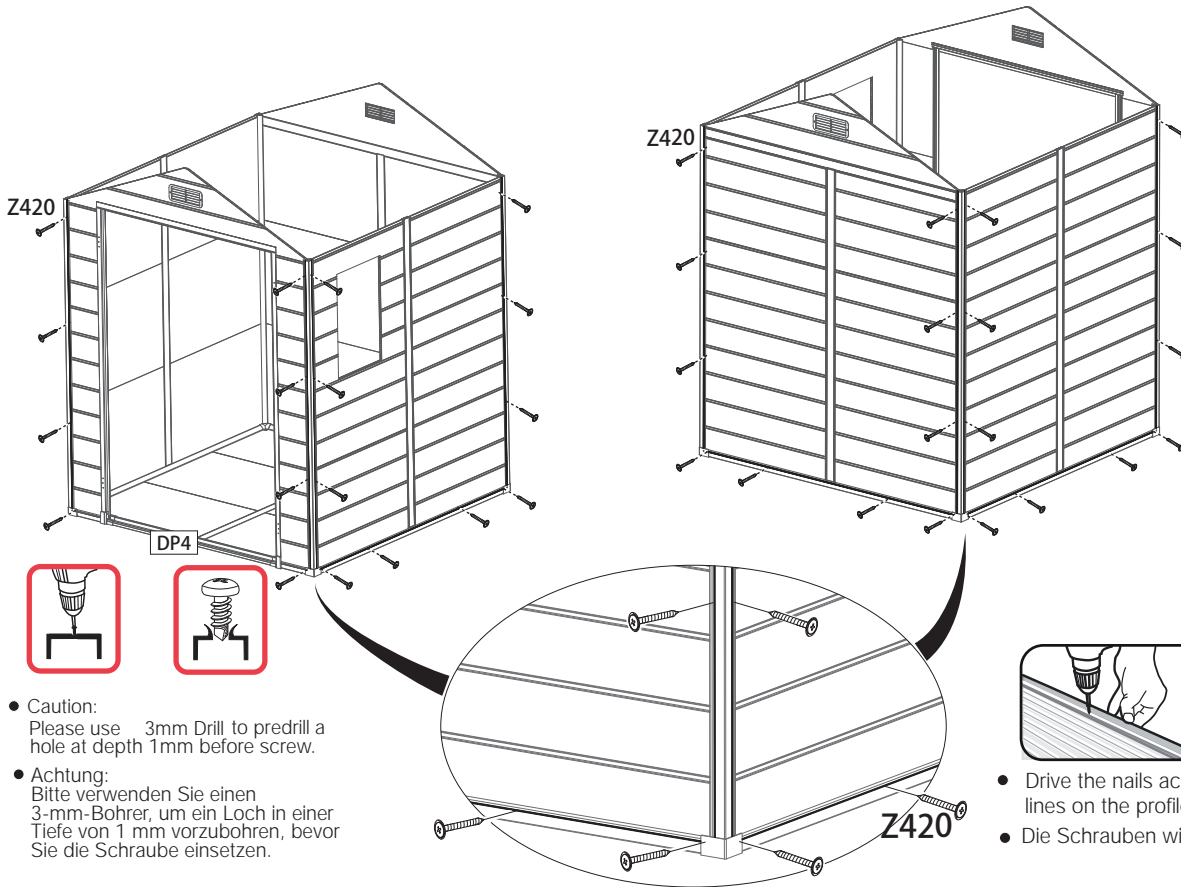

Z420

38 PC

- Caution: Please use 3mm Drill to predrill a hole at depth 1mm before screw.
- Achtung: Bitte verwenden Sie einen 3-mm-Bohrer, um ein Loch in einer Tiefe von 1 mm vorzubohren, bevor Sie die Schraube einsetzen.

- Drive the nails according to the marking lines on the profile.
- Die Schrauben wie unten gezeigt befestigen

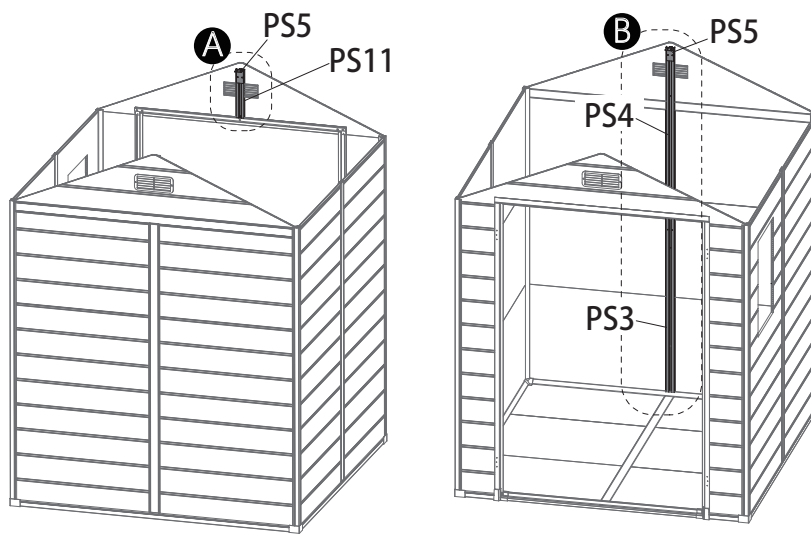

PS11

1 PC

PS3

1 PC

PS4

1 PC

PS5

2 PC

Z410

8 PC

ZW413

7 PC

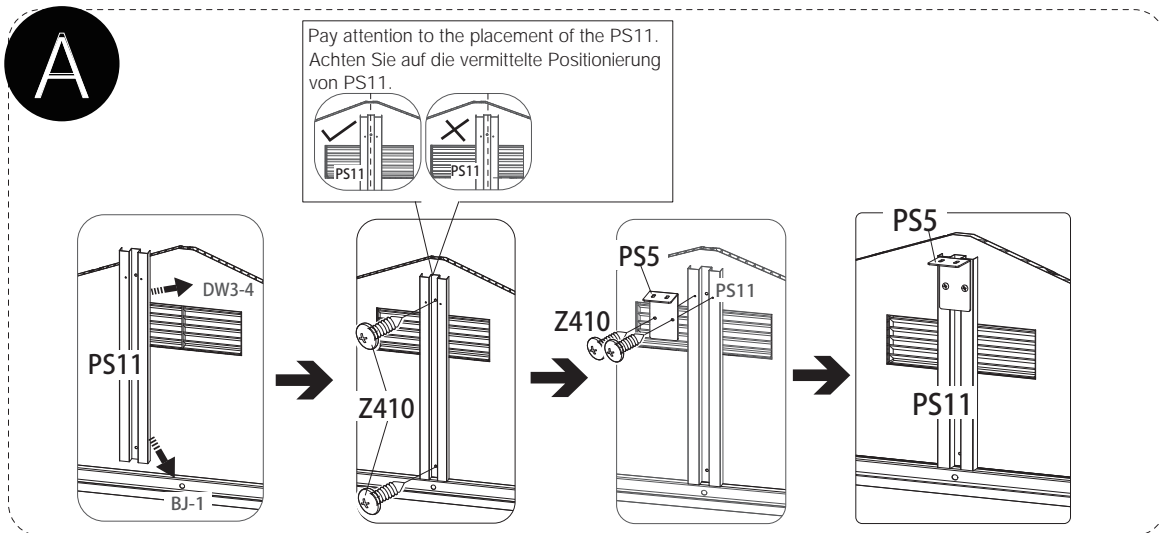

B

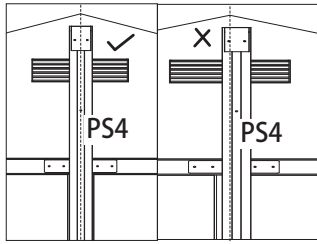

- Pay attention to the placement of the PS4.
- Achten Sie auf die vermittelte Positionierung von PS4.

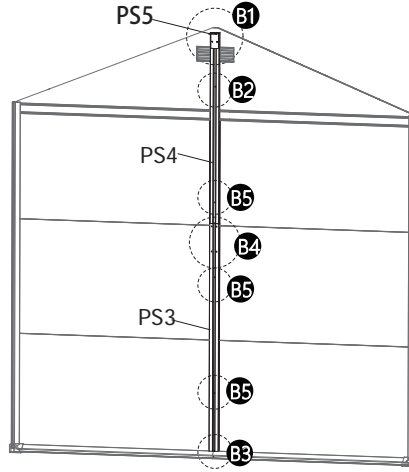

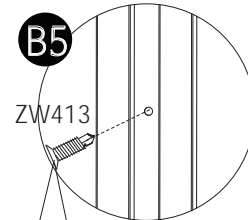
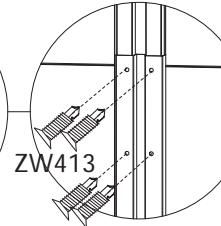
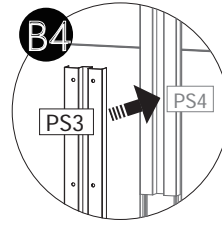
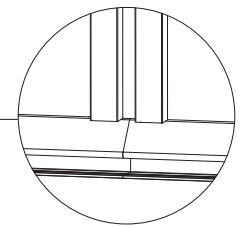
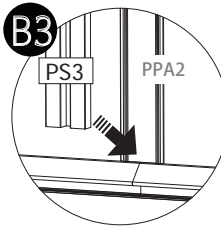
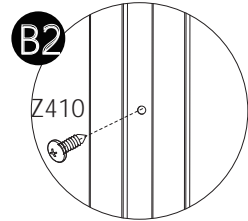
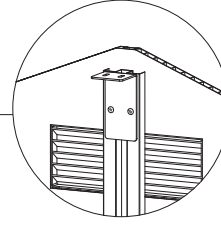
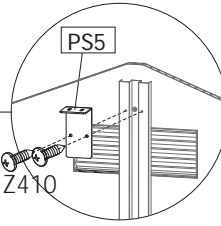
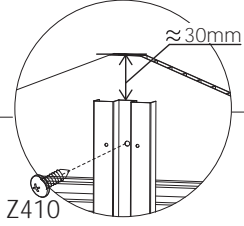
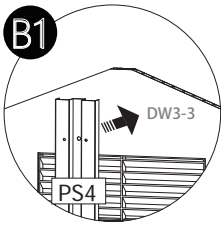

- Pay attention to measuring the dimensions
- Achten Sie auf die korrekten Abstände

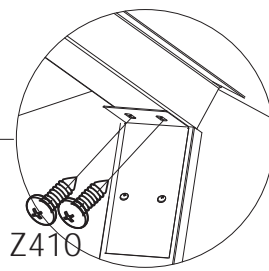
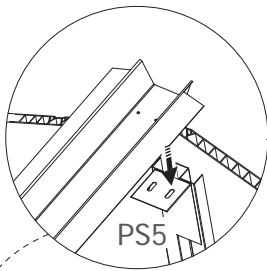

They need to be fixed on the aluminum tube inside the profile / Fixierung der Leiste mit dem Innenliegenden Profile

11



PS6-B	
	1 PC
Z410	
	4 PC

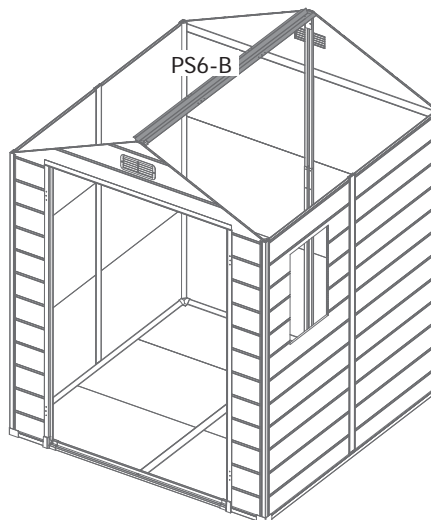
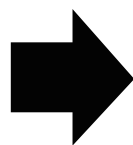
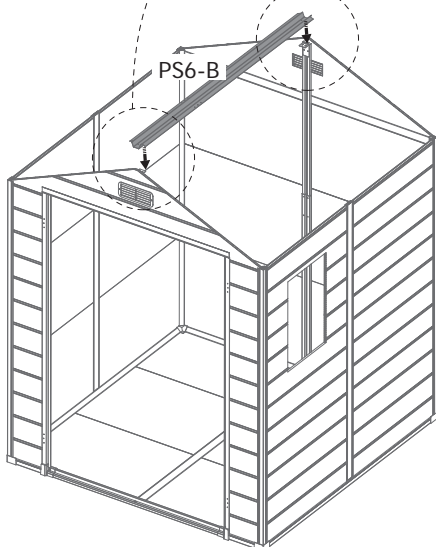

Roof section Montage Dach

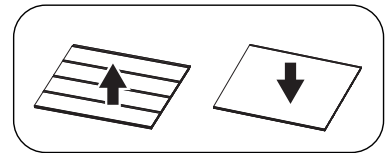
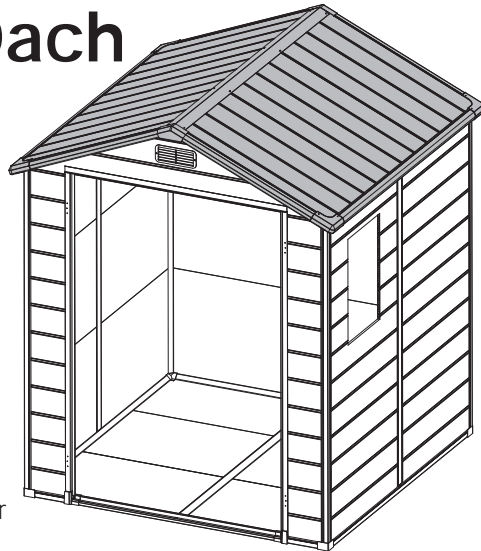

- The roofing board with a pattern is facing up.
- Die gestreifte Panelseite zeigt nach Außen.

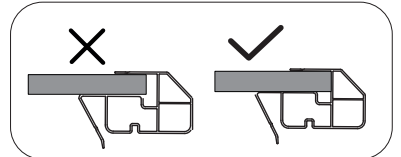

- The plates and sections should be in close contact.
- Die Panele müssen komplett im Profil liegen.

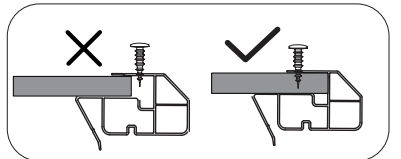

- The screws are to connect the sheet metal and the profile together.
- Die Schrauben dienen der Fixierung von Panel und Profil.

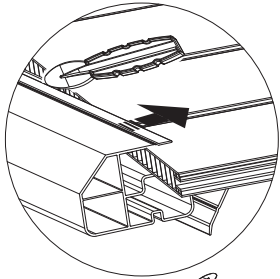

- Use spatula (part "SG8") for easier insertion of panel into profile.
- Benutzen Sie das Werkzeug "SG8" für ein leichteres Gleiten der Panele in die Profile.

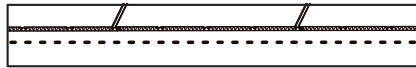

- After connecting the roof panels, they are level.
- Nach der Montage, müssen die Panele glatt ausliegen.

12

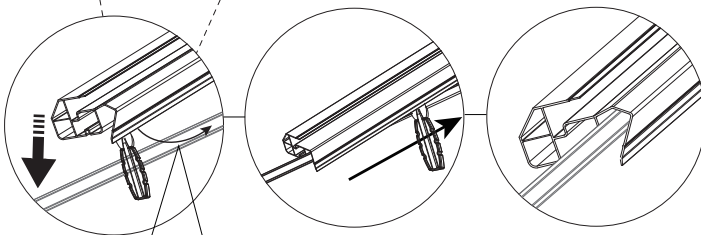
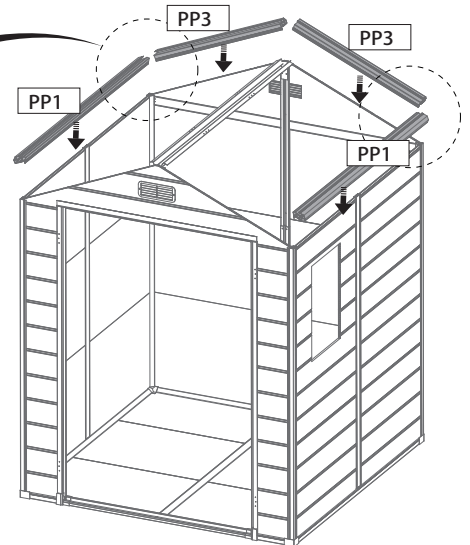
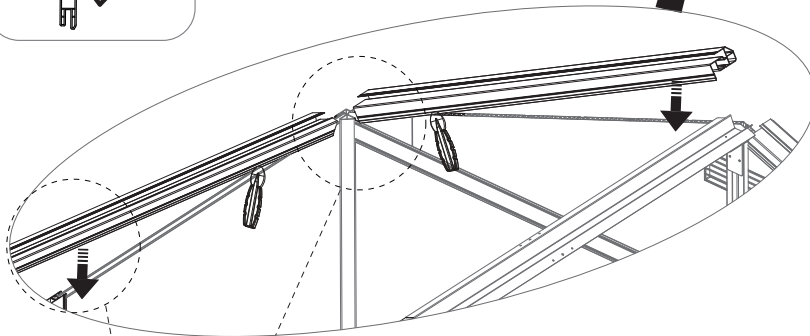
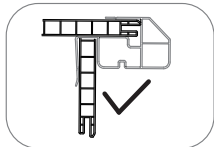
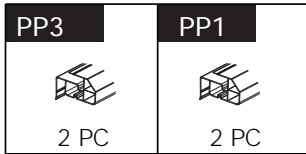

- When installing the roof profiles, use SG8 to push one side of the profiles outward to facilitate the installation of the profiles onto the wall panels.
- Verwenden Sie bei der Montage der Dachprofile SG8, um eine Seite der Profile nach außen zu drücken und so die Montage der Profile an den Wandpaneelen zu erleichtern.

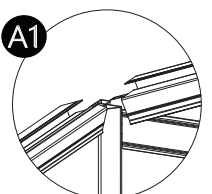
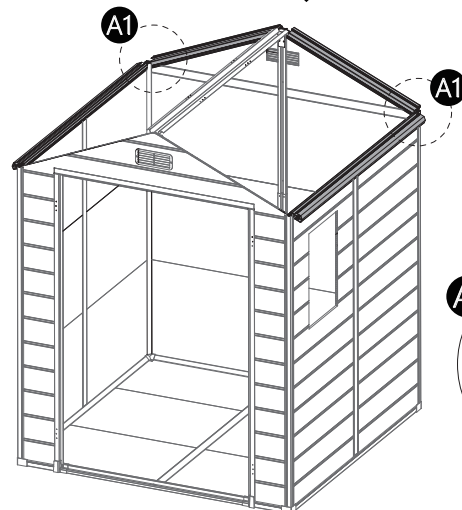

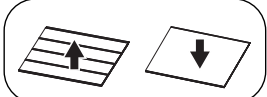



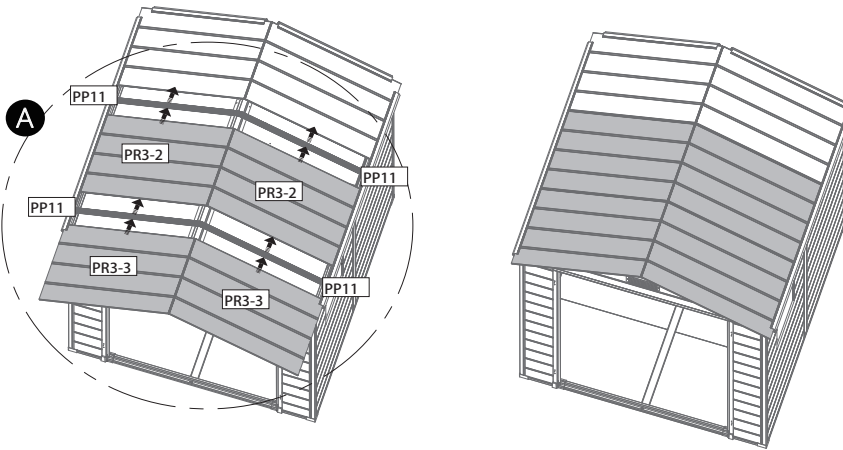
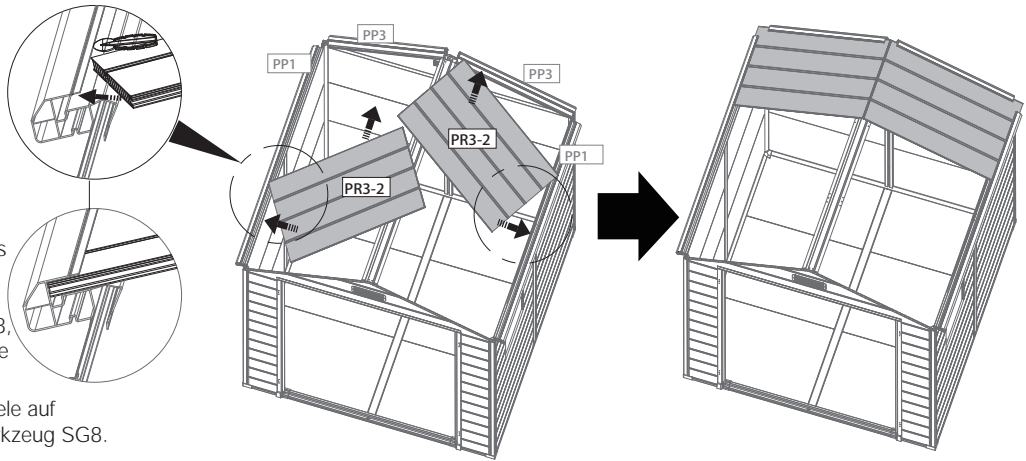

- The roofing board with a pattern is facing up.
- Die gestreifte Panelseite zeigt nach Außen.

- When installing the roof panels into the profiles, if the panels are tilted slightly and combined with the use of SG8, they will be easier to fit into the profiles.

- Beim Aufsetzen der Dachpaneele auf die Wand, nutzen sie das Werkzeug SG8.



PR3-2	
	4 PC
PP11	
	4 PC
PR3-3	
	2 PC

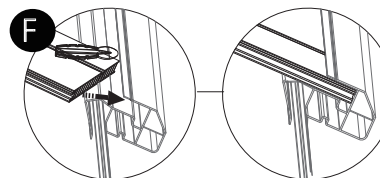
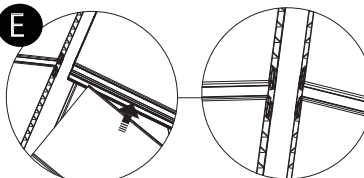
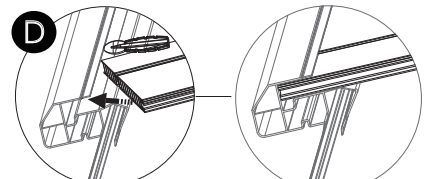
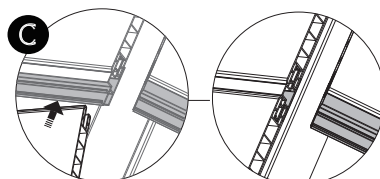
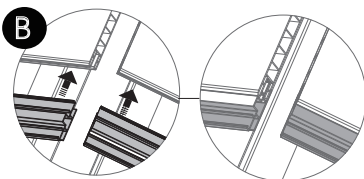
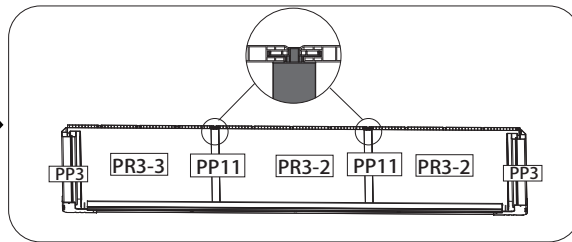
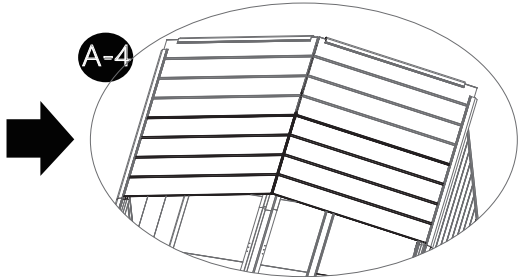
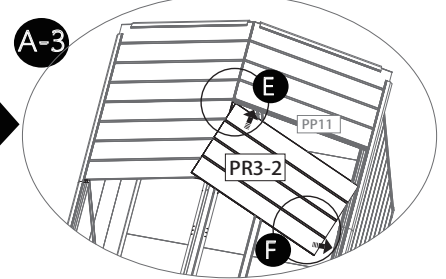
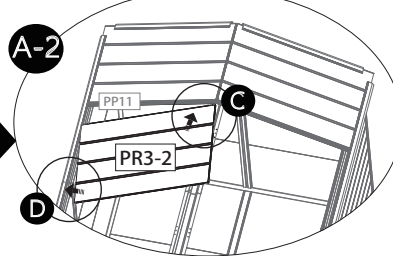
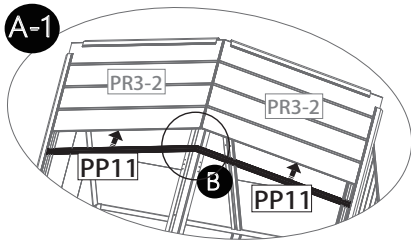

SG2



4 PC

PP3



2 PC

Z420



8 PC

Z410



8 PC

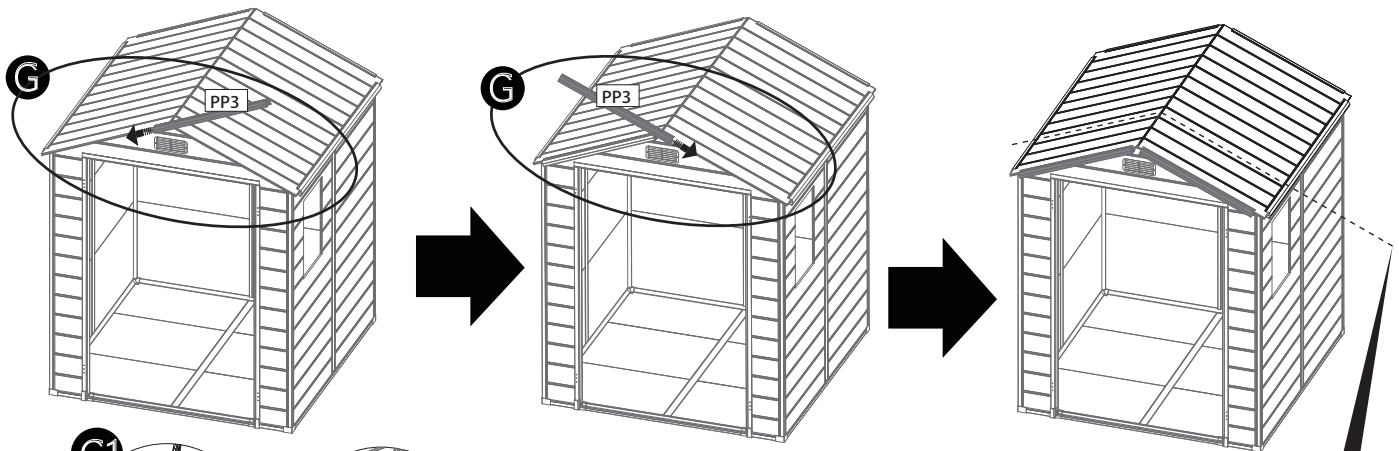

G1

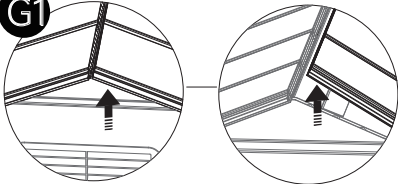

- Lift up one corner of the roof gently
- Heben Sie das Dach vorsichtig an

G2

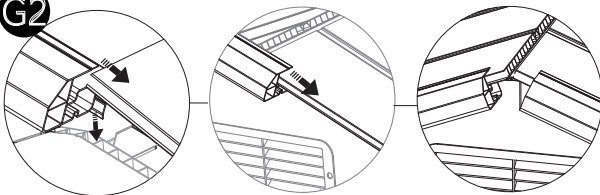

- Insert the PP3 into the corresponding wall panel and top panel at the same time, and install it at the position that fits with PS6-B.
- Führen Sie PP3 in das Dach und Wandpanel gleichzeitig ein und richten es passend für das Teil PS6-B aus.

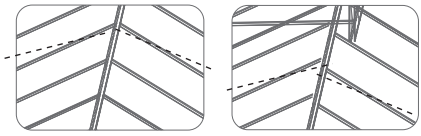

- The texture on the top plate on both sides of the roof should be aligned with each other. If they are not aligned, please lightly tap the roof profile to adjust the top plate.
- Die Fugen der Dachpaneele sollten in einer Linie sein.

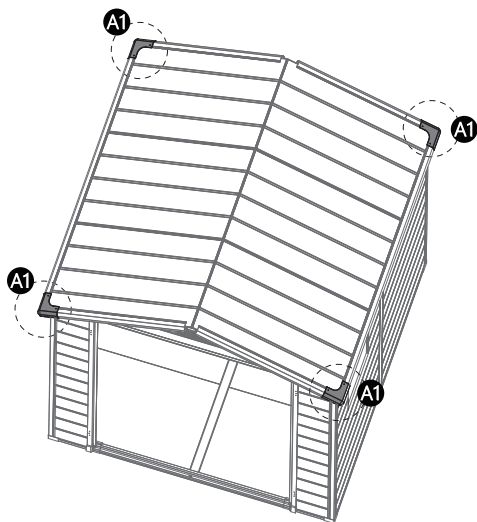

- If the SG2 does not fit the profiles on both sides, gently tap the corresponding profiles to adjust the position so that the SG2 can fit with the roof profiles.
- Wenn Teil SG2 nicht auf beiden Seiten in die Profile passt, klopfen Sie vorsichtig auf die entsprechenden Paneele, um die Position so anzupassen, damit SG2 in die Dachprofile passt.

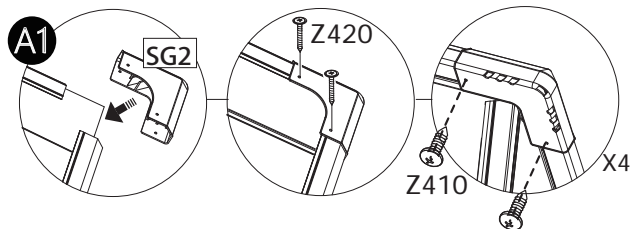

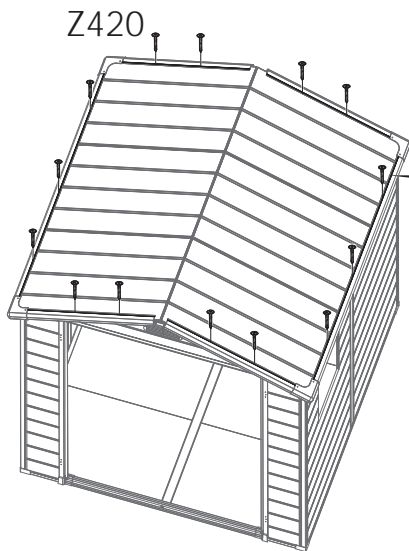

- Caution: Please use 3mm Drill to predrill a hole at depth 1mm before screw.
- Achtung: Bitte verwenden Sie einen 3-mm-Bohrer, um ein Loch in einer Tiefe von 1 mm vorzubohren, bevor Sie die Schraube einsetzen.

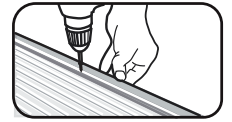

- Drive the nails according to the marking lines on the profile.
- Die Schrauben wie unten gezeigt befestigen.

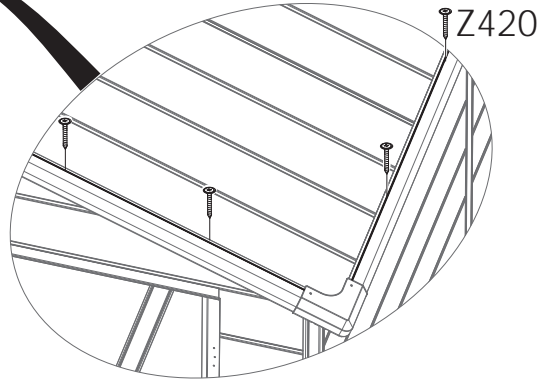

Pay attention to the positions of the screw holes.
Achten Sie auf die Position der Schraubenlöcher.

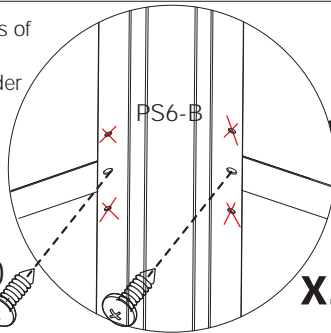

Z410 x2

- Achtung: Bitte verwenden Sie einen 3-mm-Bohrer, um ein Loch in einer Tiefe von 1 mm vorzubohren, bevor Sie die Schraube einsetzen.



- Caution: Please use 3mm Drill to predrill a hole at depth 1mm before screw.



Matters need attention:

- ① This step requires connecting PS6-B to the roof plate with screws from inside the room. To make it easier to drive the screws, please press the plate downward from the outside of the roof while driving the screws.
- ② Ensure that the distance between PP1 and PS6-B is equal before driving the nail.
- ③ It is recommended to measure and drive nails from the middle to both ends in sequence.

Zu beachten:

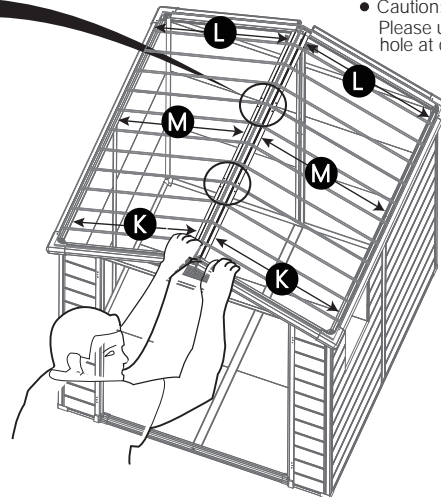
- ① In diesem Schritt wird PS6-B von innen mit Schrauben an die Dachplatte angeschlossen. Um das Eindrehen der Schrauben zu erleichtern, drücken Sie die Platte beim Eindrehen von außen nach unten.
- ② Stellen Sie sicher, dass der Abstand zwischen PP1 und PS6-B gleich ist, bevor Sie den Nagel einschlagen.
- ③ Es wird empfohlen, die Nägel von der Mitte bis zu beiden Enden zu messen und einzuschlagen.

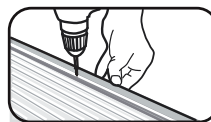
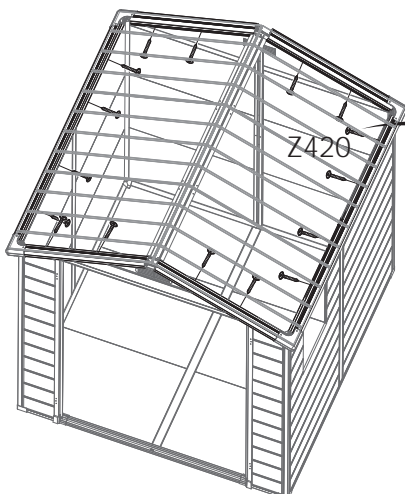

Z420

30 PC
Z410

4 PC



- Drive the nails according to the marking lines on the profile.
- Die Schrauben wie unten gezeigt befestigen.

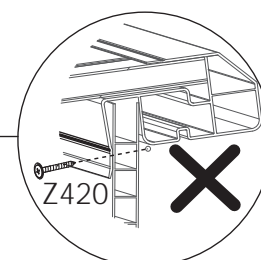
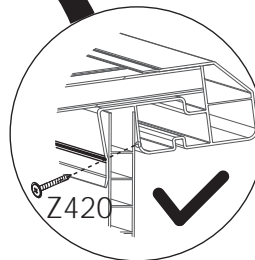

- Caution: Please use 3mm Drill to predrill a hole at depth 1mm before screw.
- Achtung: Bitte verwenden Sie einen 3-mm-Bohrer, um ein Loch in einer Tiefe von 1 mm vorzubohren, bevor Sie die Schraube einsetzen.



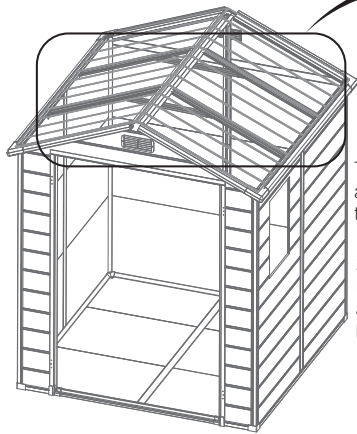

Two sets of supports are evenly installed on the roof plate and PP1.

2 Sets von Dachstützen werden am Dach und PP1-Teil befestigt.

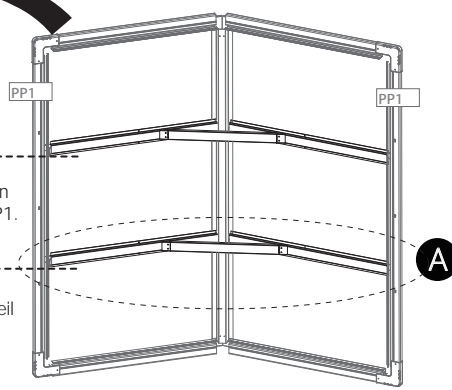

CS4-1		2 PC
CS2-5		4 PC
Z410		16 PC
Z420		8 PC
ZW413		8 PC

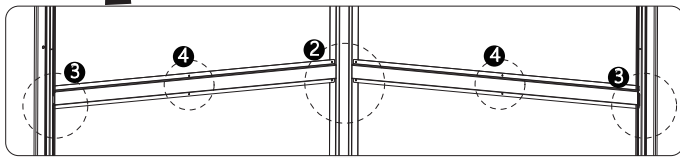
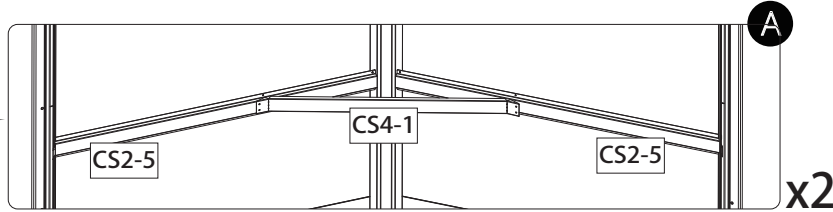

- First, fold CS2-5 here to the angle that fits PP1, and then proceed with the following installation.
- Falten Sie zuerst CS2-5 in dem Winkel, der an PP1 passt.

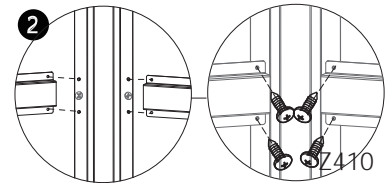
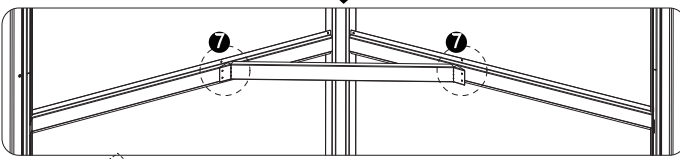
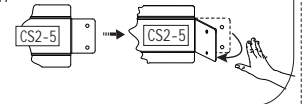

- First, fold CS4-1 here to the angle that fits CS2-5, and then proceed with the following installation.
- Falten Sie CS4-1 damit es zu CS2-5 passt.

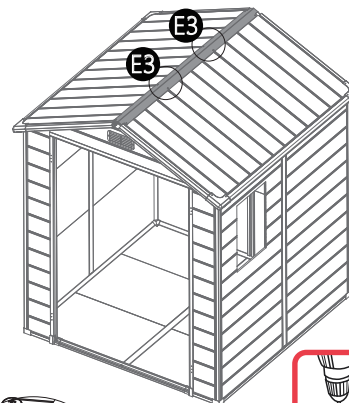
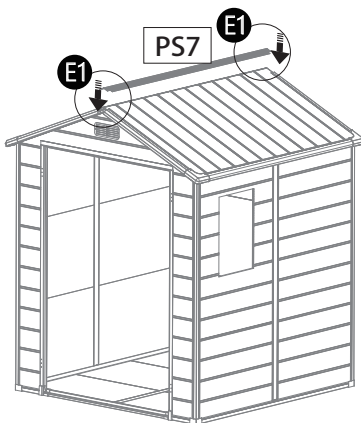
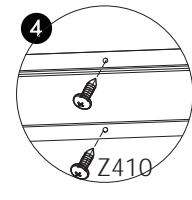
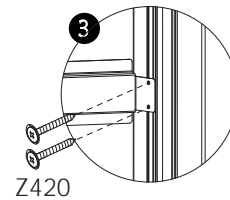
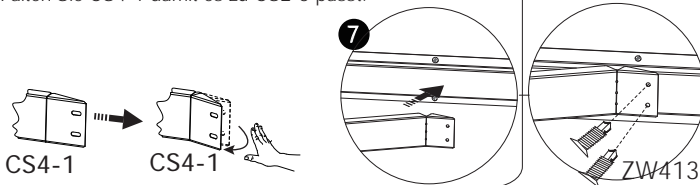

PS7		1 PC
Z410		8 PC

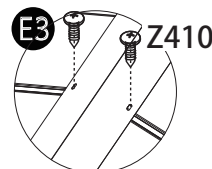
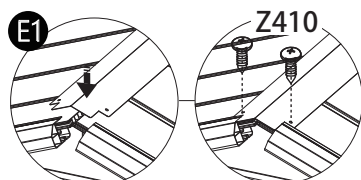

- Caution: Please use 3mm Drill to predrill a hole at depth 1mm before screw.
- Achtung: Bitte verwenden Sie einen 3-mm-Bohrer, um ein Loch in einer Tiefe von 1 mm vorzubohren, bevor Sie die Schraube einsetzen.

Window section Fenster Montage

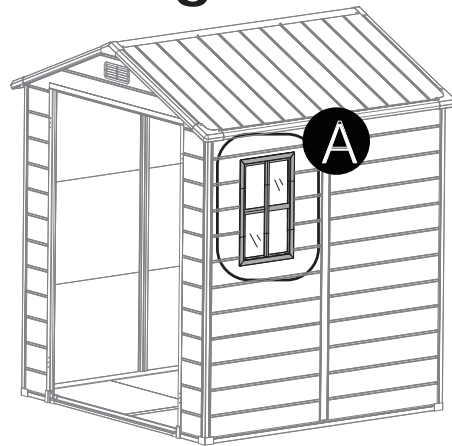

SG10

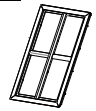

1 PC

SG101



1 PC

SG102



1PC

Z410



16 PC

A-1

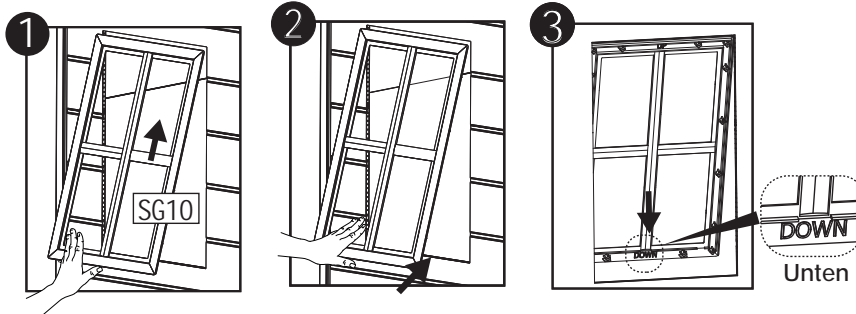

A-2

- Remove the film before fixing SG101
- Entfernen Sie zuerst die Schutzfolie.
- Two persons are needed for this step, to press SG10 from outside and inside.
- 2 Personen werden für diesen Schritt gebraucht um den Rahmen von außen und innen zu halten.

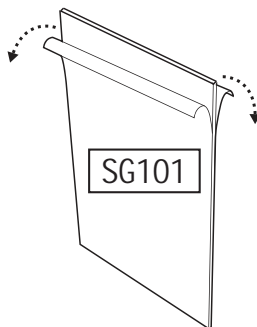

A-3

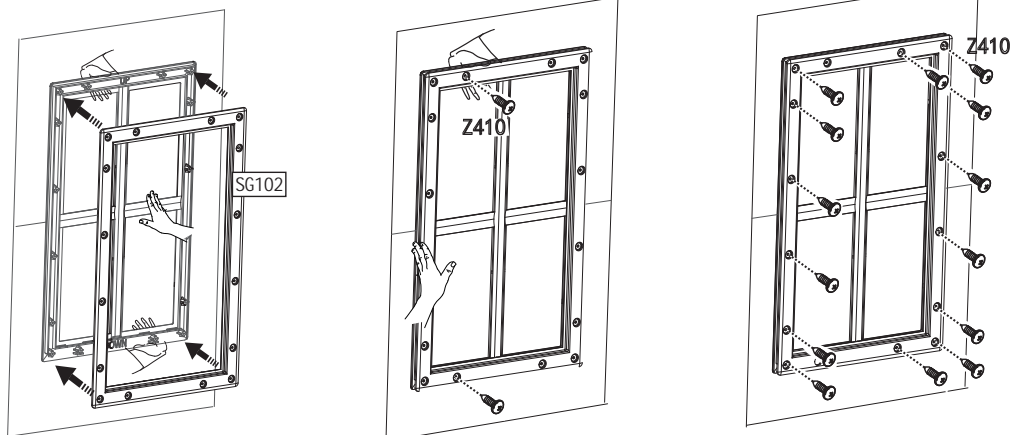

Door panel section Tür Montage

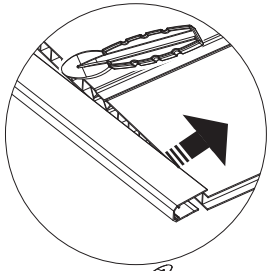

● Use spatula (part "SG8") for easier insertion of panel into profile.

● Benutzen Sie das Werkzeug "SG8" für ein leichteres Gleiten der Paneele in die Profile.

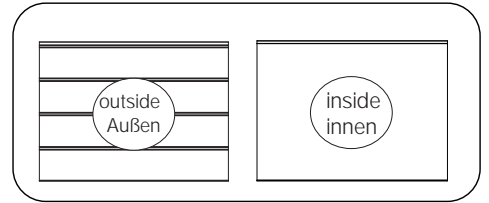
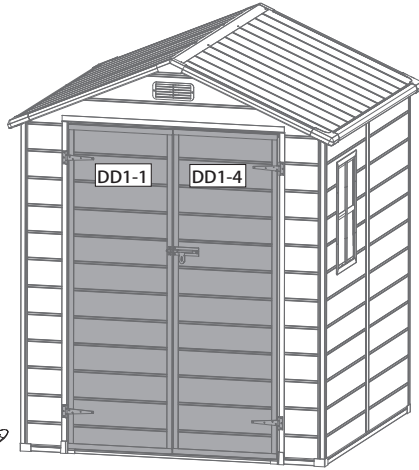

- The patterned surface of the door panel faces outward.
- Die strukturierte Oberfläche der Türverkleidung zeigt nach außen.



- After the door panels are connected, they should be aligned neatly.
- Nach dem Verbinden der Türverkleidungen sind diese ordentlich auszurichten.

19

- Please insert the SG9 into the corresponding board first.
- Führen Sie zuerst SG9 in die Paneele ein.

Left door Linke Tür

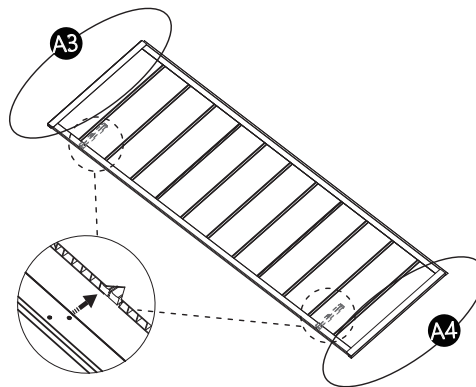
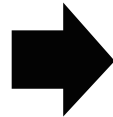
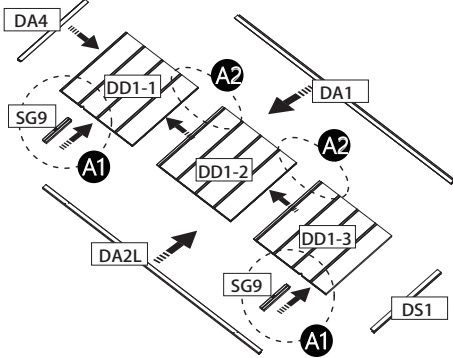

DA2L 1 PC	DA2R 1 PC	DA2 1 PC	DA1 1 PC	DD1-1 1 PC
-------------------------	-------------------------	------------------------	------------------------	--------------------------

DD1-2 1 PC

DD1-3 1 PC

DD1-4 1 PC

DD1-5 1 PC

DD1-6 1 PC

DA4 2 PC

DS1 2 PC

SG9 5 PC

Right door / Rechte Tür

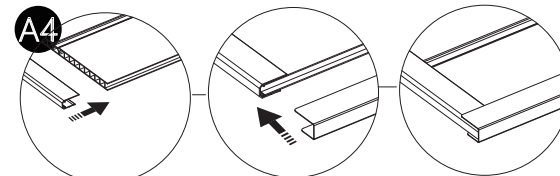
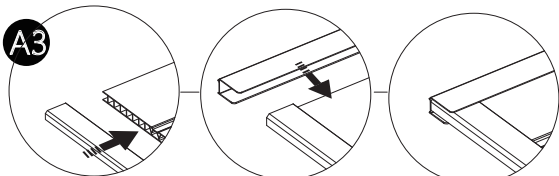
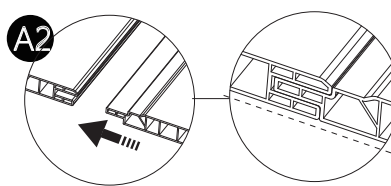
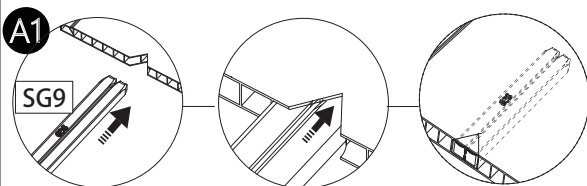
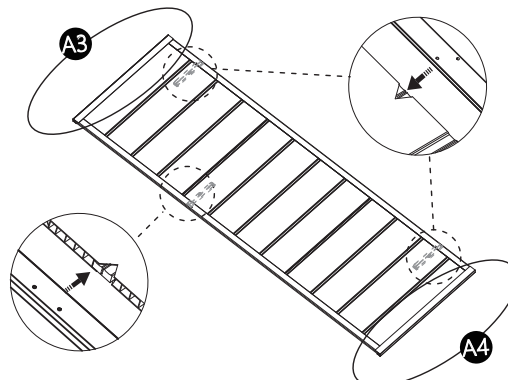
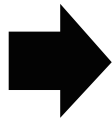
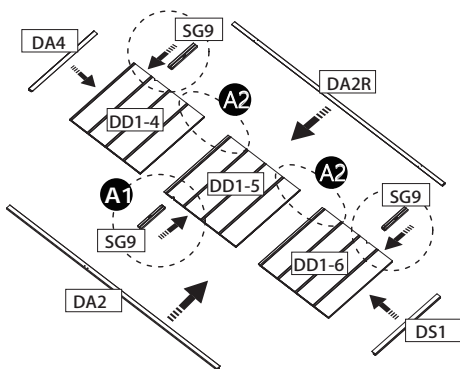

- Turn the door panel over, with the grain facing down, and then measure the diagonal of the door panel $E=F$, $L=K$, to ensure that the door panel and frame are properly installed.
- Drehen Sie die Tür, so dass die glatte Seite nach oben zeigt und richten Sie die Seiten aus, damit die Längen von $E=F$, $L=K$ entsprechen.

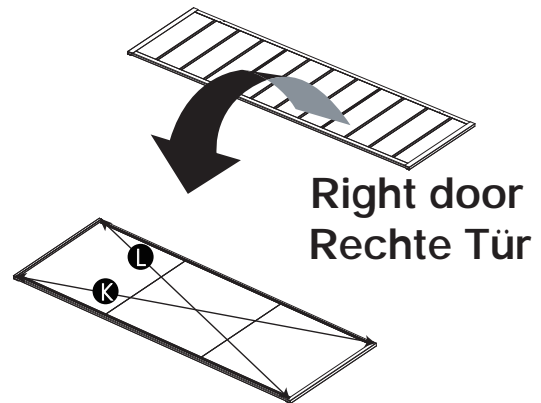
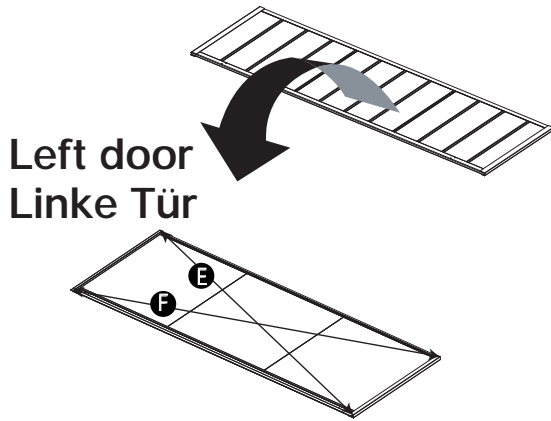

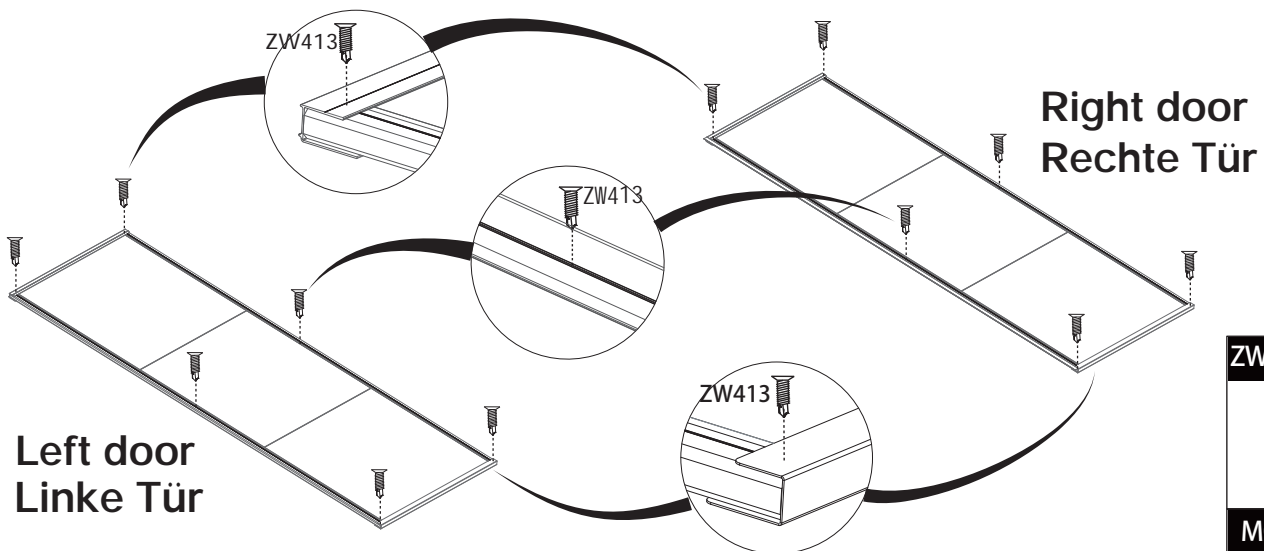

- Before driving the nail, you can first put the assembled door panel into the door frame, adjust it to match the angle of the door frame, and then drive the nail to fix it when the texture of the door panel is consistent with the texture of the wall panel.
- Bevor Sie die Schrauben fest eindrehen, können Sie die Türen in den Türrahmen stellen und sicher gehen, dass die Teile korrekt ausgerichtet sind.

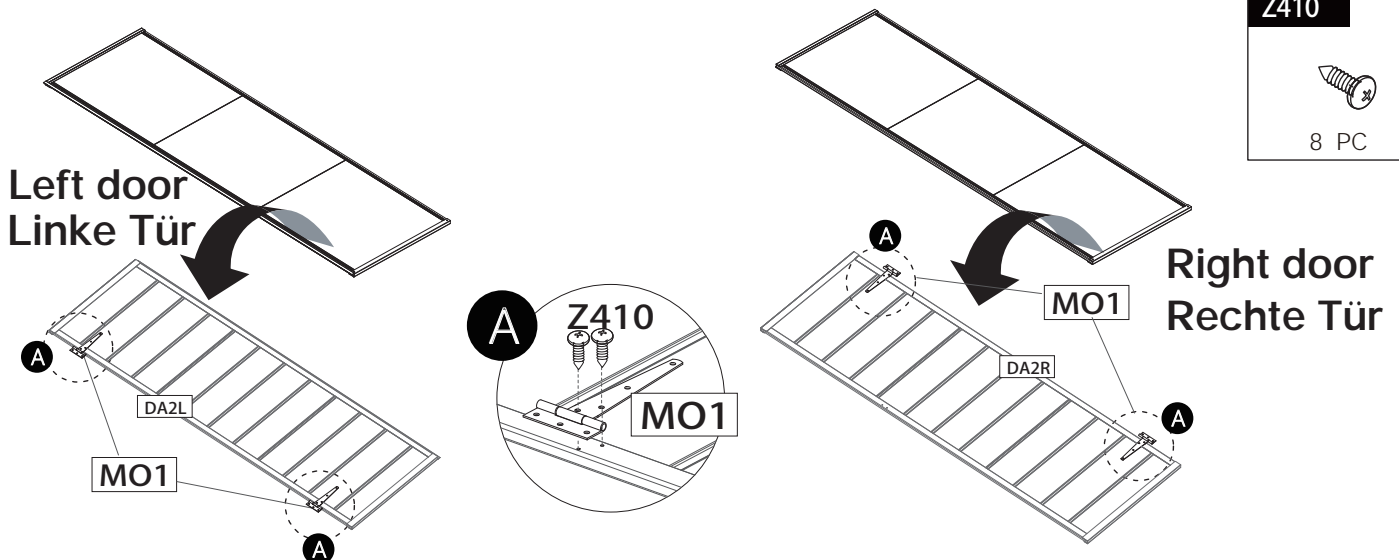

- First, flip the door panel over, with the grain facing up. Then install MO1 to the corresponding position on the door with a screw, in order to facilitate the fine adjustment of the door panel, do not tighten the screw of MO1.
- Drehen Sie die Tür mit der glatten Seite nach unten. Installieren Sie dann die Scharniere an der entsprechenden Position. Ziehen Sie die Schrauben noch nicht fest, um eine eventuell nötige Korrektur zu erleichtern.

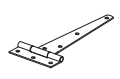

ZW413	
	12 PC
MO1	
	4 PC
Z410	
	8 PC

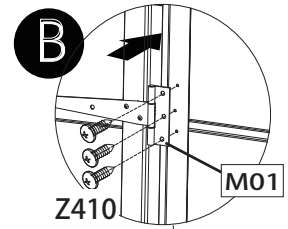
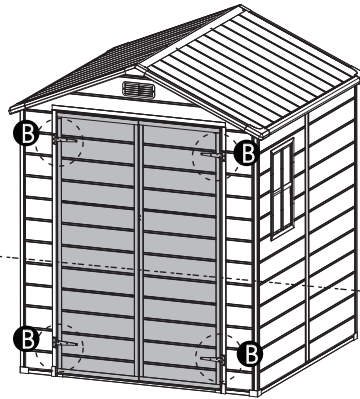
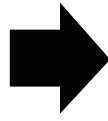

Z410

M01

Z410

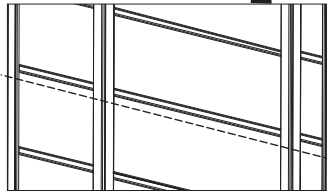
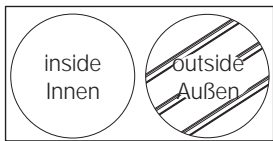

- After adjusting the position of the door panel, tighten all the screws.
- Nach korrekter Ausrichtung der Scharniere, werden die Schrauben fest eingedreht.

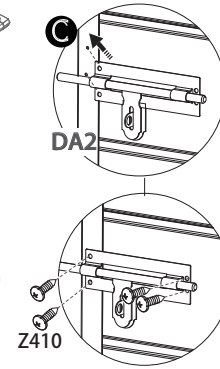
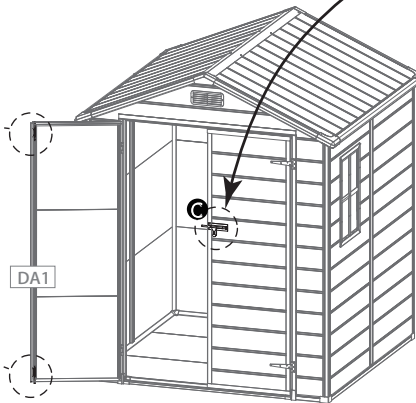
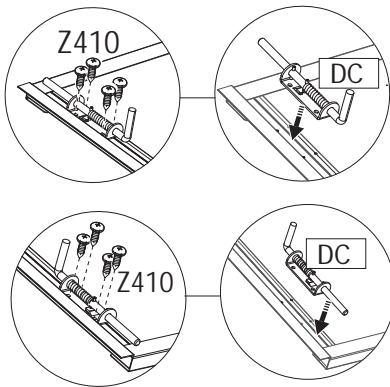
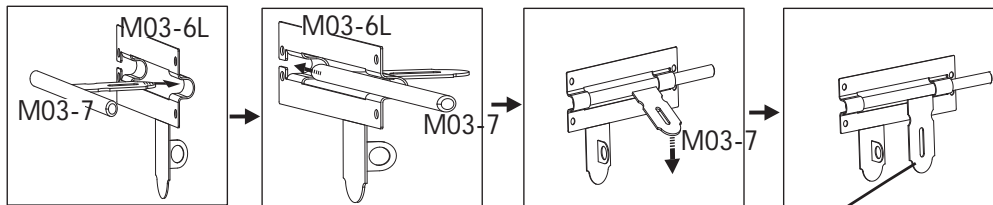

DC



2 PC

M03-6L



1 PC

M03-7

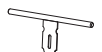

1 PC

Z410



32 PC

M04



1 PC

ZW413



2 PC

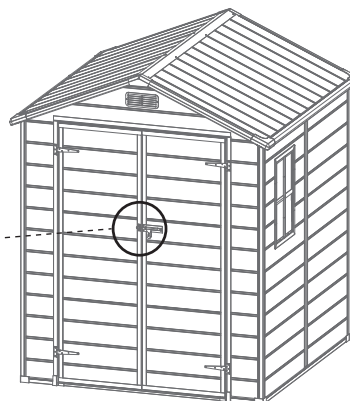
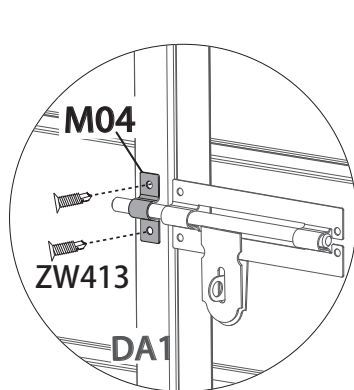



PZG4x8

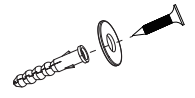

4 PC

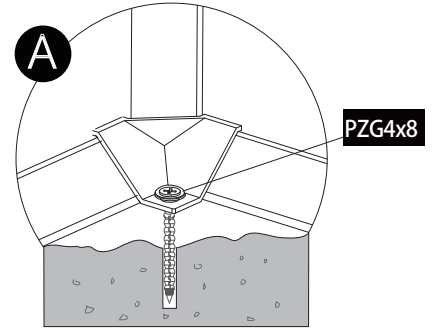

- Use an 6 drill bit to drill through the floor according to the original hole position.
- Verwenden Sie einen 6-Bohrer, um den Boden entsprechend der ursprünglichen Lochposition zu durchbohren.

- Use an 6 impact drill bit to drill a hole into the ground through the hole you just drilled.
- Verwenden Sie einen Schlagbohrer (6), um durch das gerade gebohrte Loch ein Loch in den Boden zu bohren.

