



Wasser erleben

HANSAPOLO

INSTALLATION AND MAINTENANCE GUIDE



Contents

CZ Obsah	FI Sisällysluettelo	IT Indice	PT Conteúdo
DE Inhaltsübersicht	FR Sommaire	NL Inhoud	RU Содержание
DK Indholdsfortegnelse	GR Περιεχόμενα	NO Innhold	SE Innehållsförteckning
ES Contenidos	HU Tartalom	PL Spis treści	SK Obsah

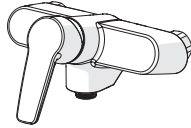

Technical data	4-5
Installation	8
Operation.....	11
Maintenance.....	11-15
Spare parts.....	16-17

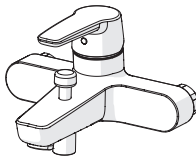

Technical data	6
Installation	8
Operation.....	11
Maintenance.....	11-15
Spare parts.....	16



Technical data	6
Installation	9
Operation.....	11
Maintenance.....	11-15
Spare parts.....	18



Technical data	7
Installation	10
Operation.....	11
Maintenance.....	11-13, 15
Spare parts.....	17

5145 0193

EN 817
50 - 1000 kPa
0.27 l/s (300 kPa)
165 kPa (0.2 l/s)
max. +80°C

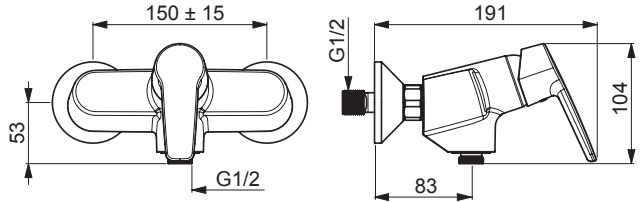

5145 0163

EN 817
50 - 1000 kPa
0.27 l/s (300 kPa)
165 kPa (0.2 l/s)
max. +80°C

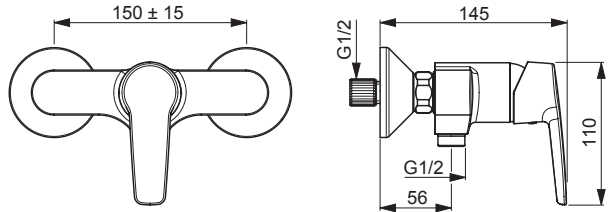

5145 0193 0067

EN 817
50 - 1000 kPa
0.27 l/s (300 kPa)
165 kPa (0.2 l/s)
max. +80°C

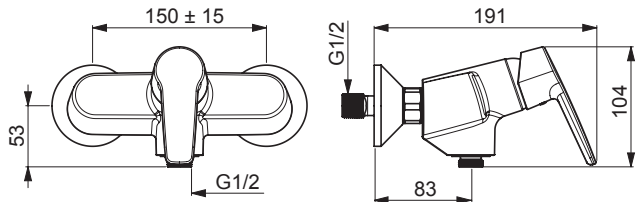

5161 2193

EN 817
I (ISO 3822)
50 - 1000 kPa
0.23 l/s (300 kPa)
230 kPa (0.2 l/s)
max. +80°C

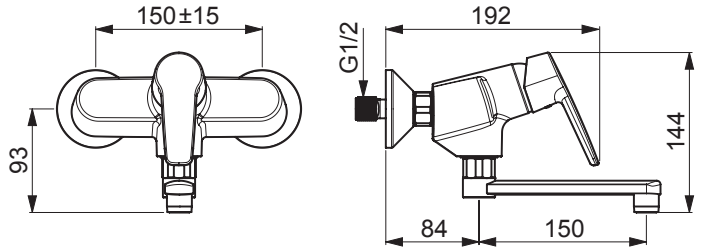

5162 2193

EN 817
I (ISO 3822)
50 - 1000 kPa
0.23 l/s (300 kPa)
230 kPa (0.2 l/s)
max. +80°C

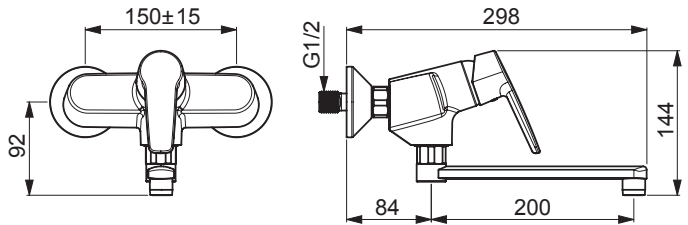

5144 2193

EN 817
 50 - 1000 kPa
 0.27 l/s (300 kPa)
 165 kPa (0.2 l/s)
 300 kPa (0.3 l/s)
 max. +80°C

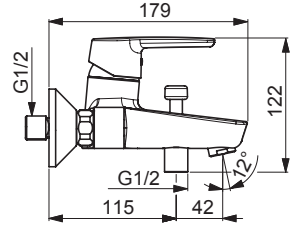
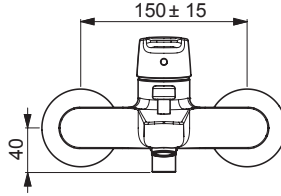

5144 2193 0067

EN 817
 50 - 1000 kPa
 0.27 l/s (300 kPa)
 165 kPa (0.2 l/s)
 300 kPa (0.3 l/s)
 max. +80°C

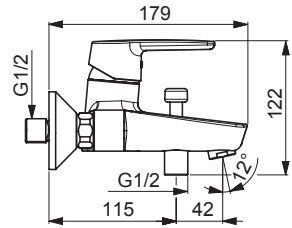
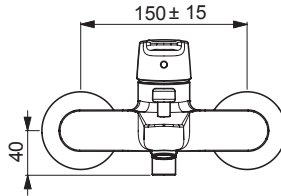

5239 2293

EN 817
 50 - 1000 kPa
 0.12 l/s (300 kPa)
 220 kPa (0.1 l/s)
 max. +80°C

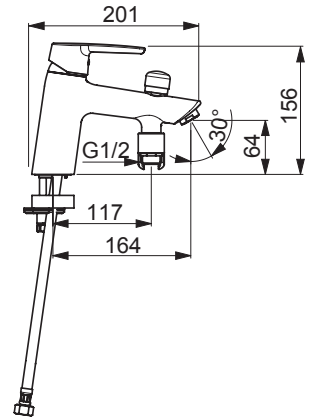
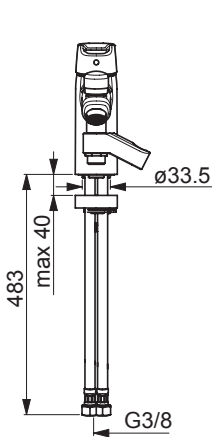

5062 9093

max. +80°C

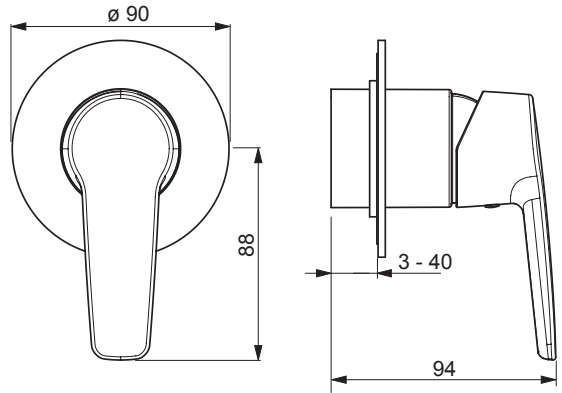

Installation

CZ Montáž

DE Montage

DK Installation

ES Montaje

FI Asennus

FR Installation

GR Συναρμολόγηση

HU Szerelés

IT Montaggio

NL Installatie

NO Montering

PL Instalacja

PT Instruções

RU Установка

SE Installation

SK Inštalácia

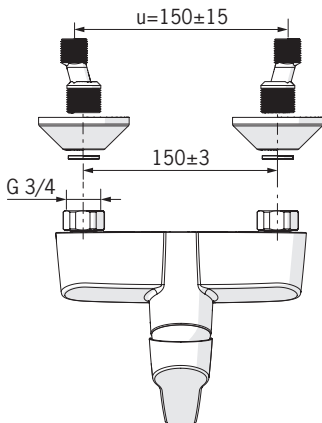
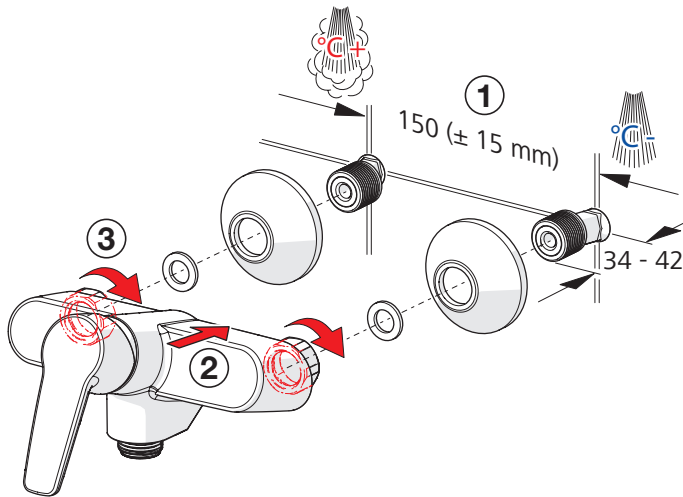
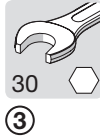
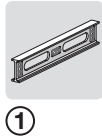
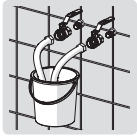
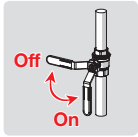

Installation

CZ Montáž

DE Montage

DK Installation

ES Montaje

FI Asennus

FR Installation

GR Συναρμολόγηση

HU Szerelés

IT Montaggio

NL Installatie

NO Montering

PL Instalacja

PT Instruções

RU Установка

SE Installation

SK Inštalácia

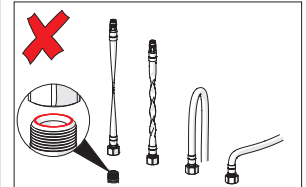
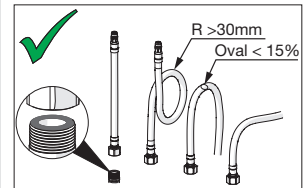
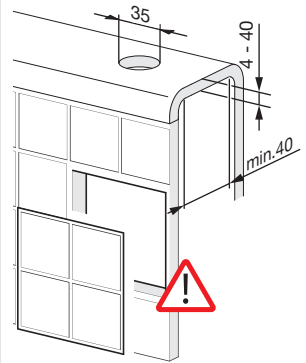
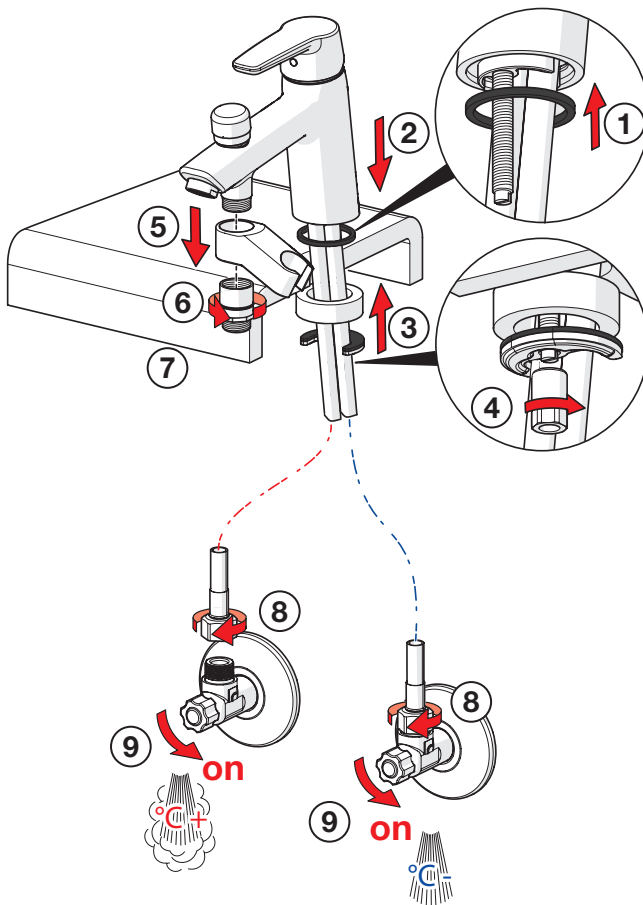
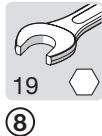
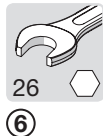
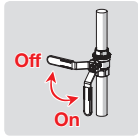

Installation

CZ Montáž

DE Montage

DK Installation

ES Montaje

FI Asennus

FR Installation

GR Συναρμολόγηση

HU Szerelés

IT Montaggio

NL Installatie

NO Montering

PL Instalacja

PT Instruções

RU Установка

SE Installation

SK Inštalácia

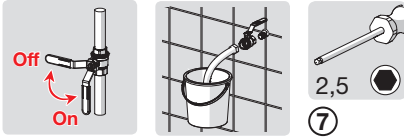

5062 9093

1

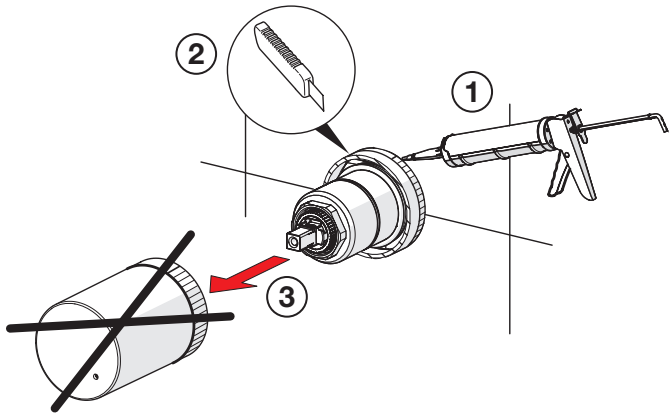

2

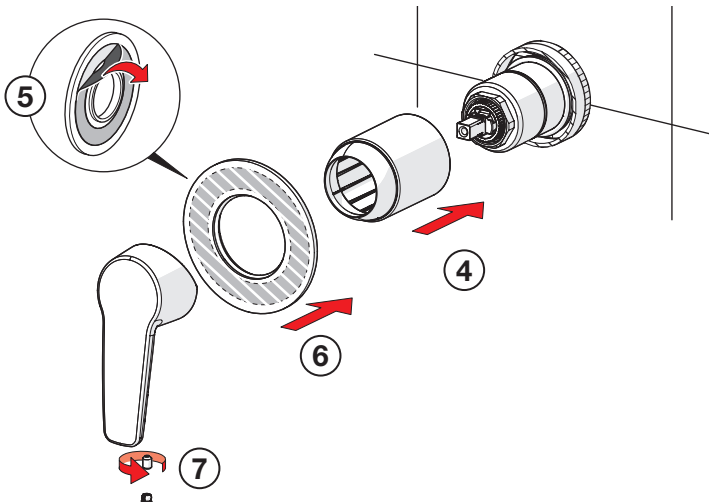

Operation

CZ Funkce	FI Toiminta	IT Funzionamento	PT Funcionamento
DE Funktion	FR Utilisation	NL Bediening	RU Принцип действия
DK Betjening	GR Λειτουργία	NO Funksjon	SE Funktion
ES Servicio	HU Üzemeltetés	PL Działanie	SK Prevádzka

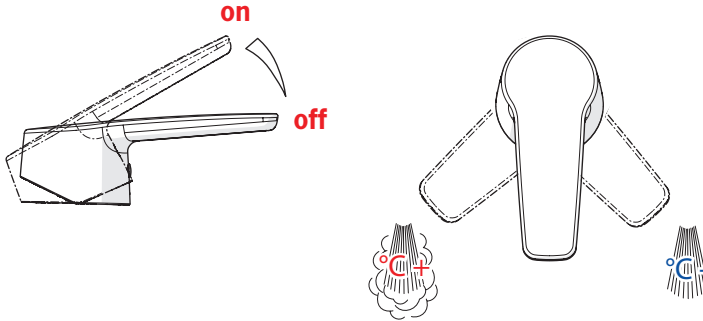

Limiting the flow rate

CZ Omezení průtoku	IT Limitazione della portata
DE Begrenzung der Durchflussmenge	NL Begrenzing van de doorstroomhoeveelheid
DK Begrænsning af vandmængden	NO Begrensning av vannmengde
ES Limitación de la tasa de flujo	PL Ograniczenie wielkości strumienia
FI Virtaaman rajoitus	PT Limitar o caudal
FR Limitation du débit	RU Регулирование потока
GR Περιορισμός ρυθμού ροής	SE Flödesbegränsning
HU Az áramlás határolása	SK Obmedzenie prietoku

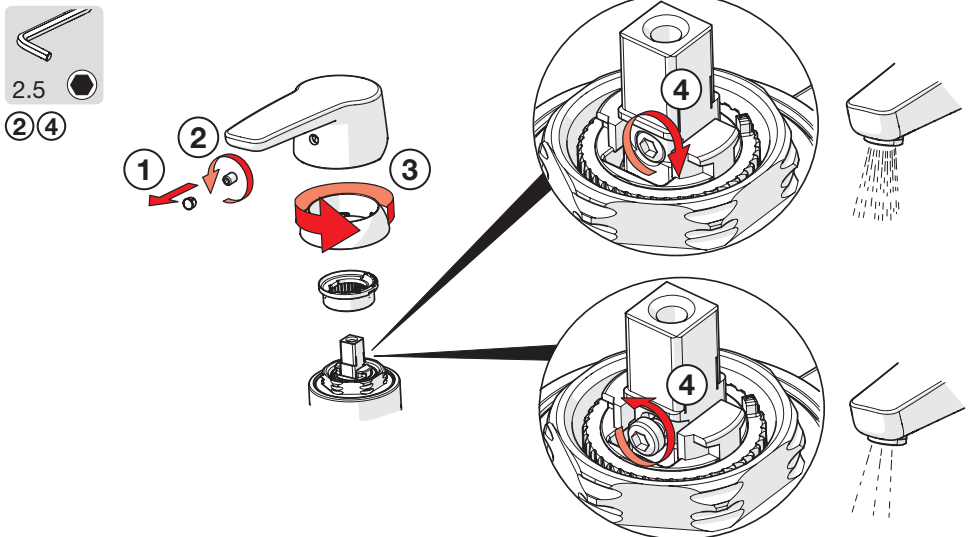

Limiting temperature

CZ Omezení teploty vody

DE Temperaturbegrenzung

DK Forindstilling af vandets max. temperatur

ES Limitación de la temperatura

FI Lämpötilan rajoitus

FR Limitation de la température

GR Περιορισμός θερμοκρασίας

HU A hőmérséklet határolása

IT Limitazione della temperatura

NL Perlator vervangent

NO Begrenzing temperatuur

PL Ograniczenie temperatury

PT Limitar a temperatura

RU Ограничение температуры в регулирующем блоке

SE Begränsning av vattnets max. temperatur

SK Obmedzenie teploty

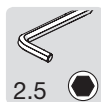

2.5

②

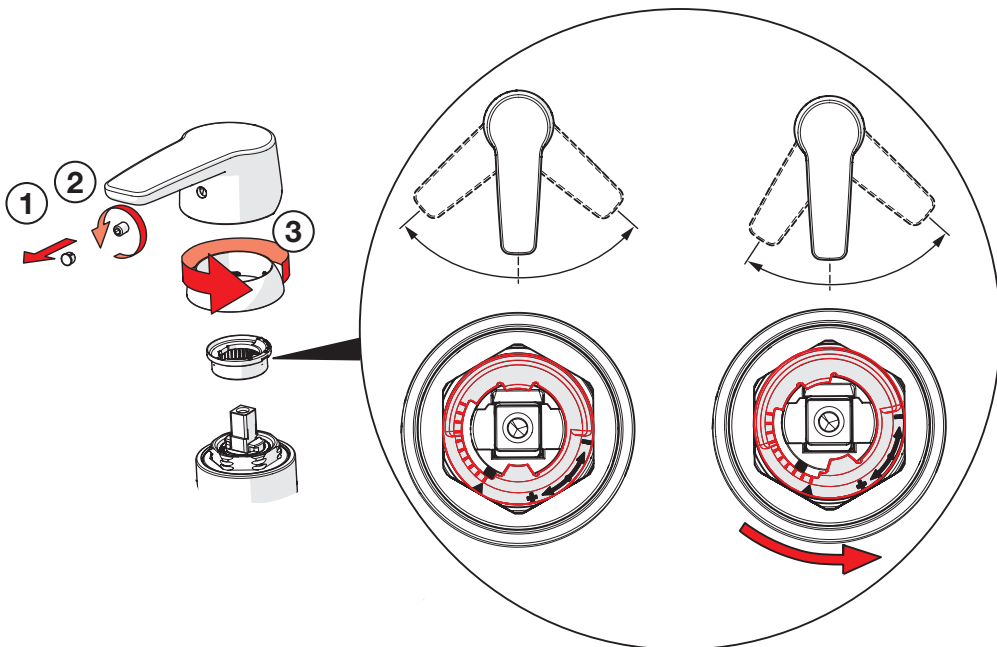

To change the cartridge

CZ Výměna kartuše

DE Auswechseln der Patrone

DK Udsiftingning af reguleringskassette (unit)

ES Montaje del cartucho

FI Säätöosan vaihto

FR Montage et démontage de la cartouche

GR Αντικατάσταση του στοιχείου

HU A patron cseréje

IT Montaggio della cartuccia

NL Vervangen van het keramische binnenwerk

NO Skifting av kassett

PL Wymiana modułu sterującego

PT Substituição do cartucho

RU Замена регулировочного блока

SE Byte av kassett

SK Výměna kartuše

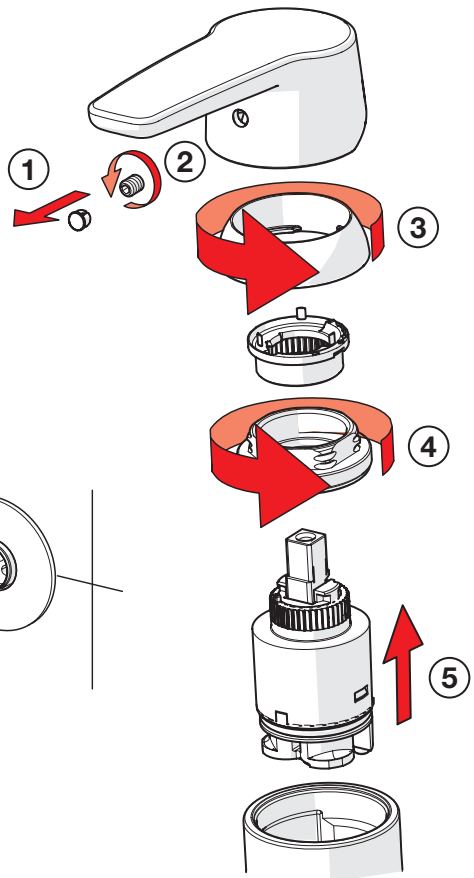
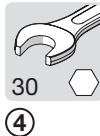
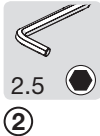
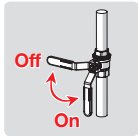

5062 9093

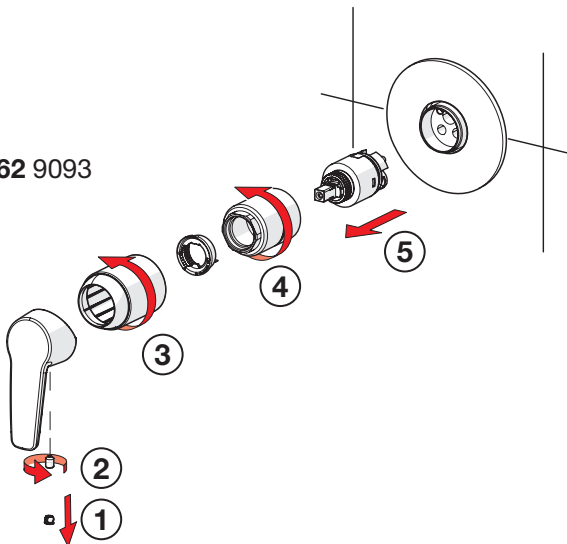

Changing the diverter

CZ Výměna přepínače

DE Wartung des Umstellers

DK Udsiftingning af omskifter

ES Cambiar la inversor

FI Vaihtimen vaihto

FR Changement de l'inverseur

GR Αλλαγή εκτροπέα

HU A zuhanyváltó cseréje

IT Sostituzione della deviatore

NL Omsteller vervangen

NO Bytting av omkaster

PL Wymiana przełącznika

PT Substituir o desviador

RU Замена переключателя

SE Byte av omkastare

SK Výměna prepínača



①

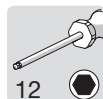

③



①

5239 2293

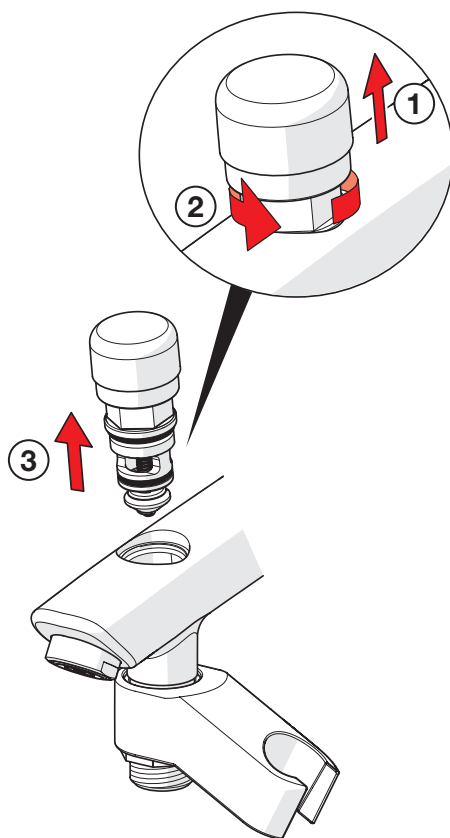
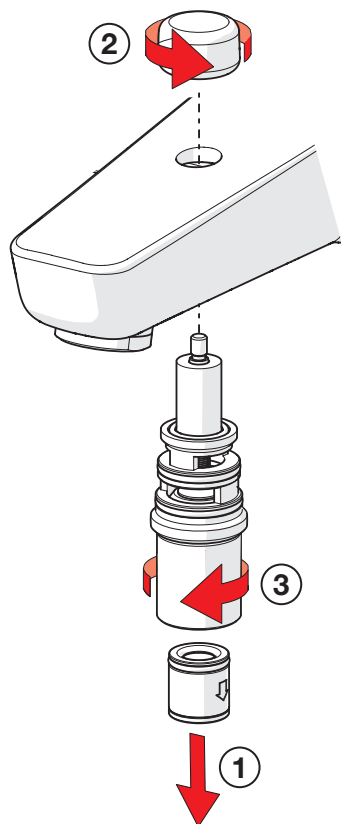

Cleaning the faucet

CZ Čištění baterie

DE Reinigung der Armatur

DK Rengøring af armaturet

ES Limpieza de la grifería

FI Puhdistus

FR Nettoyage du robinet

GR Καθαρισμός του βρύση

HU Takarítás a csapot

IT Pulizia della rubinetteria

NL Reinigen van de kraan

NO Rengjøring av kranen

PL Czyszczenie baterii

PT Limpeza da torneira

RU Чистка смесителя

SE Rengöring av blandarna

SK Čistenie vodovodnej batérie

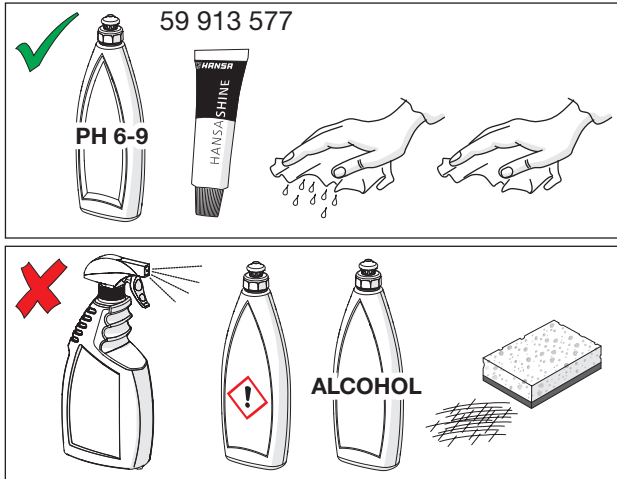

Cleaning/changing the aerator

CZ Čištění/Výměna perlátoru

DE Reinigung/Wechseln des Luftsprudlers

DK Rensning/Udskiftning af perlator

ES Limpieza/Cambiar el aireador

FI Poresuuttimen puhdistaminen/vaihtaminen

FR Nettoyage/Changement de l'aérateur

GR Καθαρισμός/αλλαγή αεριστήρα

HU Az aerátor tisztítása/cseréje

IT Pulizia/Sostituzione dell'aeratore

NL Reinigen/veranderen van de perlator

NO Rensning/Bytting av strålesamler

PL Czyszczenie/Wymiana perlatora

PT Limpar/substituir o arejador

RU Очистка и замена аэратора

SE Rengöring/Byte av strålsamlare

SK Čistenie/Výměna perlátora

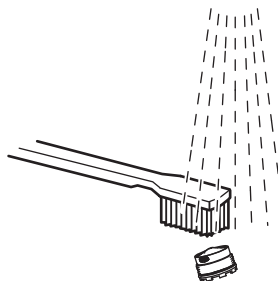

Spare parts

CZ Náhradní díly

FI Varaosat

NL Reserve-onderdelen

RU Запасные части

DE Ersatzteile

FR Pièces détachées

NO Reservedeler

SE Reservdelar

DK Reservedele

HU Alkatrészek

PL Części zamienne

SK Náhradné diely

ES Piezas de recambio

IT Pezzi di ricambio

PT Peças de reposição

5145 0193, 5145 0193 0067,

5161 2193, 5162 2193

1 59 914 417

2 59 912 504

3 59 912 325

4 59 913 210

5 59 913 075

6 59 905 714

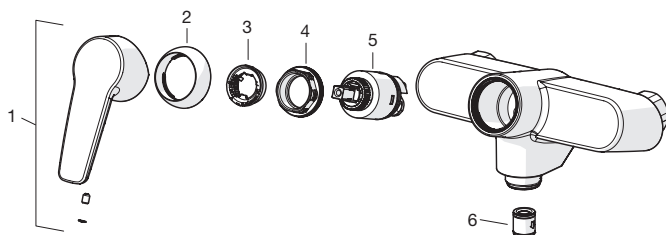

5144 2193, 5144 2193 0067

1 59 914 417

2 59 912 504

3 59 912 325

4 59 913 210

5 59 913 075

6 59 911 829

7 59 912 706

8 59 905 714

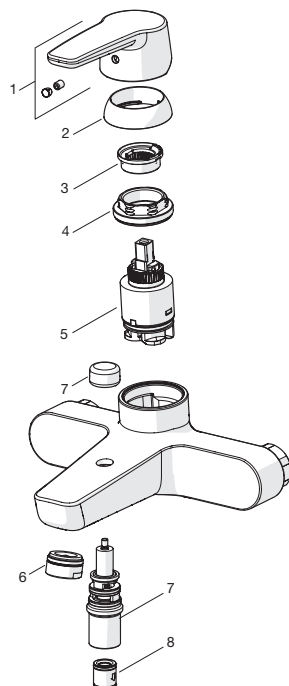

Spare parts

CZ Náhradní díly	FI Varaosat	NL Reserve-onderdelen	RU Запасные части
DE Ersatzteile	FR Pièces détachées	NO Reservedeler	SE Reservdelar
DK Reservedele	HU Alkatrészek	PL Części zamienne	SK Náhradné diely
ES Piezas de recambio	IT Pezzi di ricambio	PT Peças de reposição	

5145 0163

- 1 59 914 417
- 2 59 912 504
- 3 59 912 325
- 4 59 913 210
- 5 59 913 075

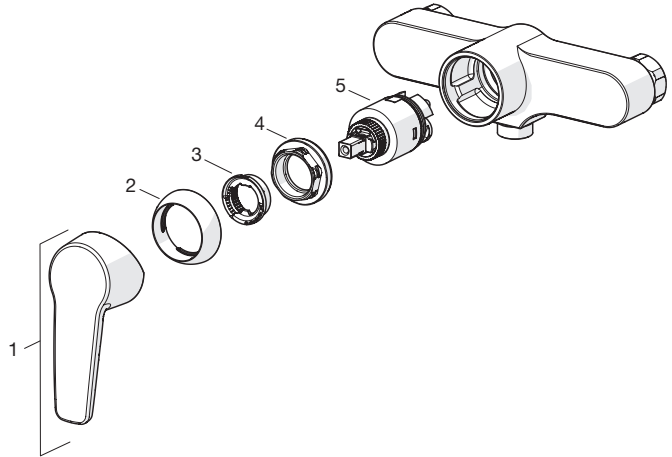

5062 9093

- 1 59 914 417
- 2 59 912 511

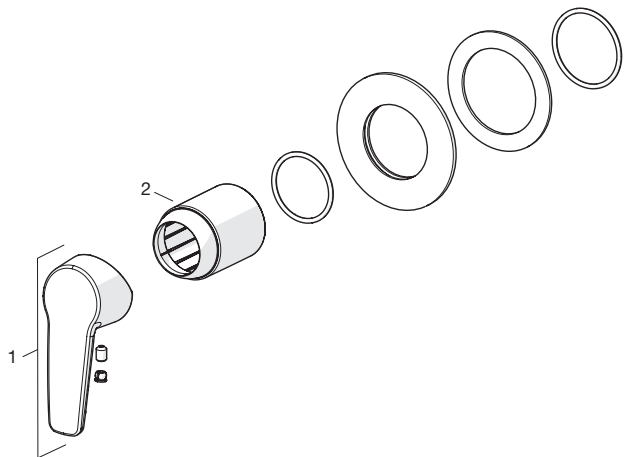

Spare parts

CZ Náhradní díly	FI Varaosat	NL Reserve-onderdelen	RU Запасные части
DE Ersatzteile	FR Pièces détachées	NO Reservedeler	SE Reservdelar
DK Reservedele	HU Alkatrészek	PL Części zamienne	SK Náhradné diely
ES Piezas de recambio	IT Pezzi di ricambio	PT Peças de reposição	

5239 2293

1	59 914 417
2	59 912 504
3	59 912 325
4	59 913 210
5	59 913 075
6	59 912 656
7	59 911 829
8	59 905 714
9	59 912 506
10	59 912 474
11	59 910 749

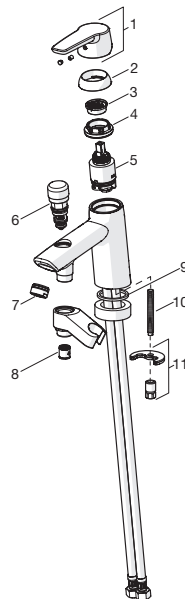

Oras Group is a powerful European provider of sanitary fittings: the market leader in the Nordics and a leading company in Continental Europe. The company's mission is to make the use of water easy and sustainable and its vision is to become the European leader of advanced sanitary fittings. Oras Group has two strong brands, Oras and Hansa.

The head office of the Group is located in Rauma, Finland, and the Group has four manufacturing sites: Burglengenfeld (Germany), Kralovice (Czech Republic), Olesno (Poland) and Rauma (Finland). Oras Group employs approximately 1400 people in twenty countries. Oras Group is owned by Oras Invest, a family company and an industrial owner.

HANSA Armaturen GmbH
P. O. BOX 81 02 40
D-70519 Stuttgart

Sigmaringer Strasse 107
D-70567 Stuttgart
Tel.: +49 711 16 14 0
Fax: +49 711 16 14 368
info@hansa.de

www.hansa.com



a member of  orasgroup