



# ELBA PLUS

SECATOALLAS ELÉCTRICO DIGITAL PROGRAMABLE

## CARACTERÍSTICAS

### CONTROL Y TECNOLOGÍA



Panel táctil con pantalla LCD



Modo Confort, Eco y Anti-hielo



Optimum Flux Tech



Termostato de alta sensibilidad



**PRODUCTO CON PANEL REVERSIBLE**  
Disponible para realizar pedido con panel de control en el colector izquierdo.

### EFICIENCIA



Función Ventanas Abiertas

### FUNCIONALIDAD



Programable 24/7



Bloqueo de panel

### DISEÑO Y ACABADOS

**STEEL**

Cuerpo 100% acero



Blanco RAL 9016



Negro Mate RAL 9005



Cromo espejo



Modelo expuesto  
TELL2N40B77 - Elba Plus 300W blanco

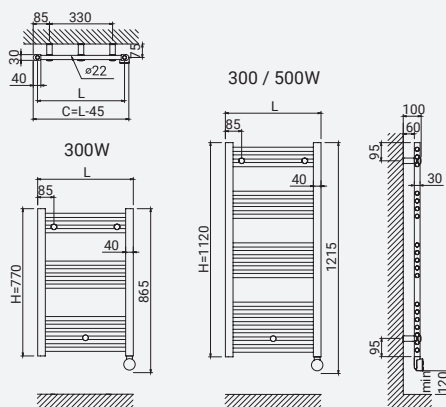

## ESPECIFICACIONES TÉCNICAS

MODELOS	Blanco	TELL2N40B077	TELL2N40B112	TELL2N50B077	TELL2N50B112
	Negro	TELL2N40N077	TELL2N40N112	TELL2N50N077	TELL2N50N112
	Cromo	TELL2N40C077	TELL2N40C112	TELL2N50C077	TELL2N50C112
Potencia Nominal (W)	Blanco / Negro	300	500	300	500
	Cromo	300	300	300	300
Número de tubos		12	19	12	19
Ancho - L (mm)		400	400	500	500
Peso (Kg)		6,1	9,8	10,6	15,9
Área recomendada (m <sup>2</sup> )		Hasta 3 m <sup>2</sup>	Hasta 5 m <sup>2</sup>	Hasta 3 m <sup>2</sup>	Hasta 5 m <sup>2</sup>
Acabados		Blanco RAL 9016 / Negro mate RAL 9005 / Cromo		Blanco RAL 9016 / Negro mate RAL 9005 / Cromo	
EAN13	Blanco	8435556164104	8435556164111	8435556164043	8435556164050
	Negro	8435556164142	8435556164159	8435556164081	8435556164098
	Cromo	8435556164128	8435556164135	8435556164067	8435556164074
P.V.R. <sup>1</sup>	Blanco	191 €	228 €	196 €	236 €
	Negro	212 €	254 €	217 €	263 €
	Cromo	231 €	292 €	240 €	306 €

1) IVA no incluido. El producto incluye cable de 1,4 m con clavija (salida lateral derecho), soportes, kit + plantilla de instalación y manual de usuario.