

GLOBE MOKA

Componenti Struttura Esterna / External structure components / Bauteile Aussenkorpus / Composants structure externe / Componentes estructura externa

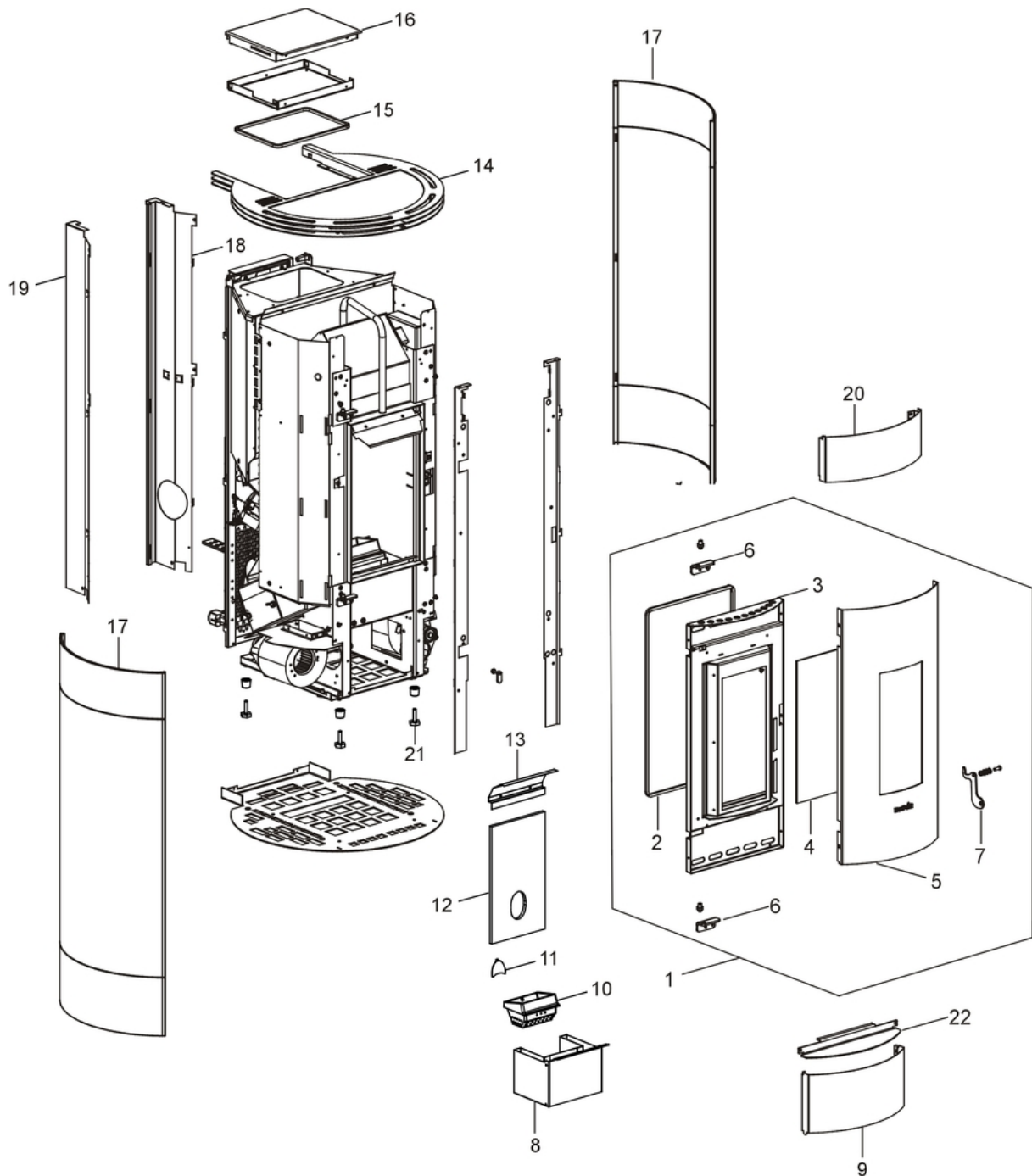

N°	Codice/Code	Descrizioni / Description / Beschreibung / Description / Descripción
1	4D245GP15003	Porta fuoco completa / Complete door / Komplette Tür / Porte complète / Puerta completa
2	4D18013021A	Guarnizione treccia nera D.10 - 5 M / Black twist gasket D.10 - 5 M / Dichtung D.10 - 5 M / Joint tresse noire D.10 - 5 M / Junta D.10 - 5 M
2	4D18013021B	Guarnizione treccia nera D.10 - 50 M / Black twist gasket D.10 - 50 M / Dichtung D.10 - 50 M / Joint tresse noire D.10 - 50 M / Junta D.10 - 50 M
3	4D170140010	Vetroceramico 385x175x4 mm / Glass 385x175x4 mm / Glasskeramikscheibe 385x175x4 mm / Vitrocéramique 385x175x4 mm / Cristal cerámico 385x175x4 mm
4	4D170140010	Vetroceramico 385x175x4 mm / Glass 385x175x4 mm / Glasskeramikscheibe 385x175x4 mm / Vitrocéramique 385x175x4 mm / Cristal cerámico 385x175x4 mm

4	4D18013008A	Guarnizione 10x3 (5m) / Gasket 10x3 (5m) / Dichtung 10x3 (5m) / Joint 10x3 (5m) / Junta 10x3 (5m)
4	4D18013008B	Guarnizione 10x3 (50m) / Gasket 10x3 (50m) / Dichtung 10x3 (50m) / Joint 10x3 (50m) / Junta 10x3 (5m)
5	4D24014954361	Telaio esterno porta fuoco / External door frame / Aussere Feuertürrahmen / Cadre extérieure porte / Armazón externo puerta
6	4D2401303720	Supporto porta nero / Black door support / Schwarzes Türhaltebügel / Support porte noir / Soporte puerta negro
6	4D2401303720	Supporto porta nero / Black door support / Schwarzes Türhaltebügel / Support porte noir / Soporte puerta negro
7	4D24014066161	Maniglia / Handle / Griff / Poignée / Tirador
7	4D24015841361	Kit decompressione camera di combustione / Pressure relief kit / Bausatz Überdruckablauf Brennkammer / Kit decompression chambre de combustion / Kit decompression cámara de combustión
8	4D24014015461	Cassetto cenere / Ash drawer / Aschenkasten / Tiroir à cendres / Cajón ceniza
9	4D24014951317	Pannello frontale inferiore Moka / Moka lower frontal panel / Vorderes unteres Paneel Moka / Panneau antérieur inférieur Moka / Panel frontal inferior Moka
9	4D24014951396	Pannello frontale inferiore White / White lower frontal panel / Vorderes unteres Paneel White / Panneau antérieur inférieur White / Panel frontal inferior White
10	4D13013001	Braciere / Grate / Brennschale / Braser / Braser
11	4D2401303101	Deflettore pellet / Pellet deflector / Pellet Leitblech / Deflecteur pellet / Deflector pellet
12	4D115140020	Schiena in Calorite / Calorite back / Rückwand aus Calorite / Fond en Calorite / Parte trasera de Calorite
13	4D242140043	Supporto Vermiculite / Vermiculite support / Vermiculite Halterung / Support Vermiculite / Soporte Vermiculite
14	4D24014959461	Top nero / Black top / Abdeckplatte Schwarz / Dessus noir / Top negro
15	4D18013016	Guarnizione 155X190 mm / Gasket 155X190 mm / Dichtung 155x190 mm / Joint 155X190 mm / Junta 155X190 mm
16	4D24014020361	Coperchio serbatoio pellet / Pellet hopper cover / Deckel Pelletbehälter / Couvercle réservoir pellet / Tapadera depósito
17	4D24014962317	Fianco DX-SX Moka / R.-L. Moka side / RE.-LI. Aussenseite Moka / Côté D-G Moka / Lateral DCHO-IZDO Moka
17	4D24014962317	Fianco DX-SX Moka / R.-L. Moka side / RE.-LI. Aussenseite Moka / Côté D-G Moka / Lateral DCHO-IZDO Moka
17	4D24014962396	Fianco DX-SX White / R.-L. White side / RE.-LI. Aussenseite White / Côté D-G White / Lateral DCHO-IZDO White
17	4D24014962396	Fianco DX-SX White / R.-L. White side / RE.-LI. Aussenseite White / Côté D-G White / Lateral DCHO-IZDO White
18	4D24014057363	Montante posteriore DX / Rear R. vertical rod / Hintere R. Montageleiste / Montant postérieur D. / Montante posterior DCHO
19	4D24014058363	Montante posteriore SX / Rear L. vertical rod / Hintere L. Montageleiste / Montant postérieur G. / Montante posterior IZDO
20	4D24014953361	Pannello frontale superiore nero / Upper black frontal panel / Vorderes oberes Paneel schwarz / Panneau antérieur supérieur noir / Panel frontal superior negro
21	4D12013006	Piedini di appoggio (4 pz.) / Support feet (4 pcs.) / Einstellfüße (4 Stck.) / Vérins (4 pcs) / Pies de apoyo (4 pzs)
22	4D24014952363	Sottoporta nero / Door protection / Schutz unter der Tür / Protection sous porte / Resguardo abajo puerta

GLOBE MOKA

Componenti interni meccanici ed elettronici / Electronic and mechanic internal parts / Interne mechanische und elektronische Bauteile / Composants internes mécaniques et électroniques / Componentes internos electrónicos y mecánicos

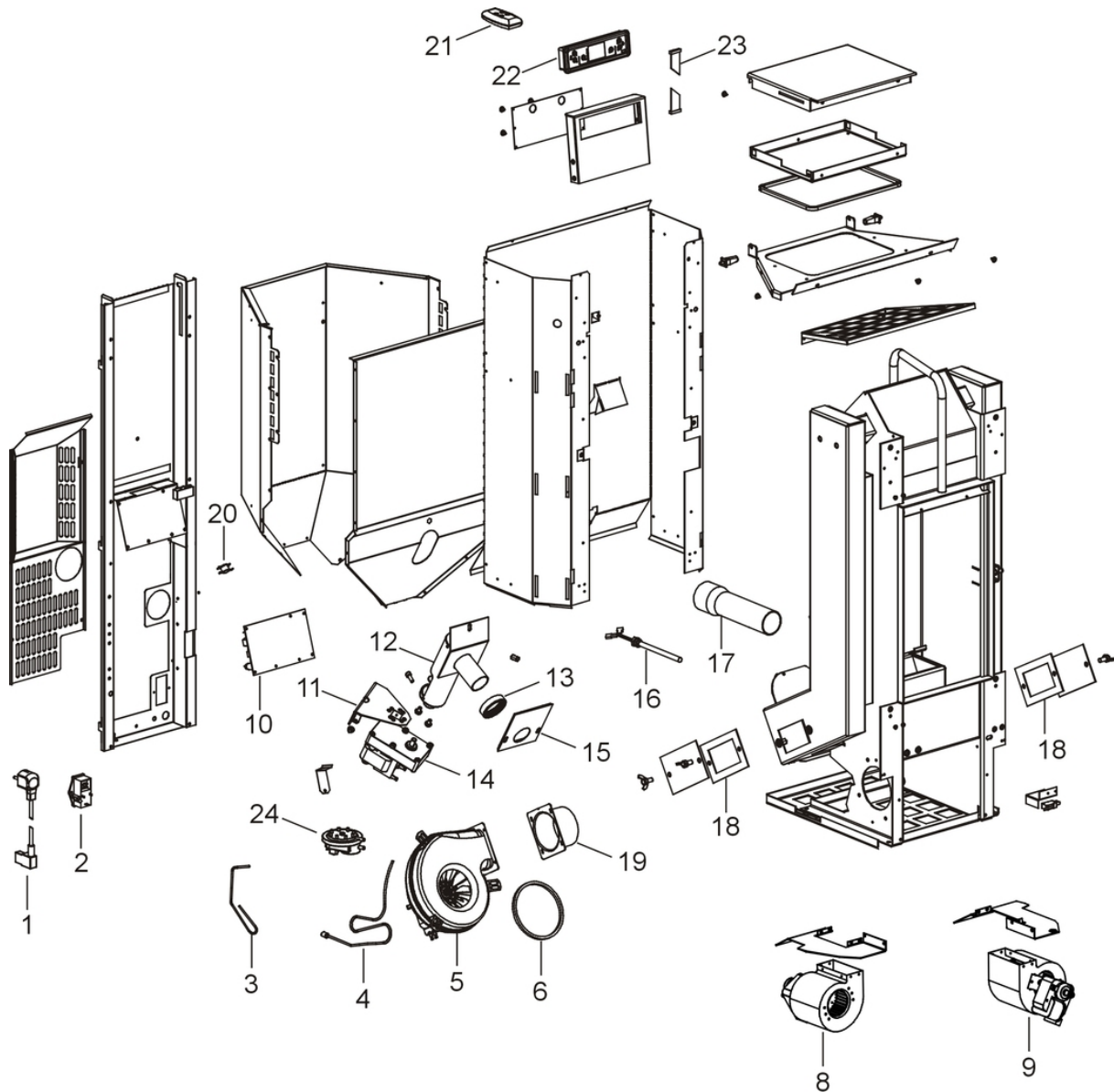

N°	Codice/Code	Descrizioni / Description / Beschreibung / Description / Descripción
1	4D14513041	Cavo alimentazione / Power source cable / Zündungskabel / Câble alimentation / Cable alimentación
2	4160193	Pulsante accensione / On/Off button / Zündungstaste / Touche d'allumage / Botón encendido
3	4D14513015	Sonda fumi / Smoke sensore / Rauchgassonde / Sonde fumées / Sonda humos
4	4D14513017	Sonda ambiente / Room temperature sensor / Raumtemperaturfühler / Sonde température ambiance / Sonda ambiente
5	4D145140150	Ventilatore fumi stagno / Tin smoke fan / Hermetisch Dichtrauchgebläse / Ventilateur fumées étanche / Ventilador humos hermético
6	4D18013024	Guarnizione / Gasket / Dichtung / Joint / Junta
8	4D14513054	Ventilatore aria / Air fan / Luftgebläse / Ventilateur air / Ventilador aire
9	4D14513054	Ventilatore aria / Air fan / Luftgebläse / Ventilateur air / Ventilador aire
10	4D14513064	Scheda madre / Motherboard / Hauptplatine / Carte mère / Tarjeta madre
10	4D14513064B	Scheda madre / Motherboard / Hauptplatine / Carte mère / Tarjeta madre

11	4D2401302613	Supporto coclea / Feed screw support / Schnecke Halterung / Support de la vis-sans-fin / Soporte cóclea
12	4D12013057	Assieme coclea - Versione corta con albero femmina / Auger set - Short version with female shaft / Förderschnecke / Groupe vis sans fin - Version courte avec arbre femelle / Cóclea
13	4D18013003	Guarnizione D.50 mm / Gasket D.50 mm / Dichtung D.50 mm / Joint D.50 mm / Junta D.50 mm
14	41450901600	Motoriduttore 3,3 rpm Merkle Korff / Reduction motor 3,3 rpm Merkle Korff / Getriebemotor 3,3 RPM MERKLE KORFF / Motoréducteur 3,3 RPM MERKLE KORFF / Motorreductor 3,3 rpm Merkle Korff
14	4D145159010	Motoriduttore 3,3 rpm / Reduction motor 3,3 rpm / Getriebemotor 3,3 rpm / Motoréducteur 3,3 rpm / Motorreductor 3,3 rpm
15	4D18013004	Guarnizione 100X108 mm / Gasket 100X108 mm / Dichtung 100x108 mm / Joint 100X108 mm / Junta 100X108 mm
16	4D14513002	Candeletta / Sparkplug / Zündkerze Pelletzündung / Bougie / Bujía encendido pellet
17	4D160140040	Tubo ingresso aria 60x2x210 mm / Air inlet pipe 60x2x210 mm / Lufteingangrohr 60x2x210 mm / Tuyau entrée air 60x2x210 mm / Tubo entrada aire D.80 L.200 mm
17	4D18013003	Guarnizione D.50 mm / Gasket D.50 mm / Dichtung D.50 mm / Joint D.50 mm / Junta D.50 mm
18	4D18013001	Guarnizione 130x80 mm / Gasket 130x80 mm / Dichtung 130x80 mm / Joint 130x80 mm / Junta 130x80 mm
18	4D18013001	Guarnizione 130x80 mm / Gasket 130x80 mm / Dichtung 130x80 mm / Joint 130x80 mm / Junta 130x80 mm
19	4D14513040	Raccordo D.80 mm / Connector D.80 mm / Anschlußrohr D.80 mm / Raccord D.80 mm / Racor D.80 mm
20	4D14513006	Termostato 60°C / Thermostat 60°C / Thermostat 60°C / Thermostat 60°C / Termostato 60°C
21	4D14513055	Telecomando / Remote control / Fernbedienung / Télécommande / Mando a distancia
22	4D14513032	Pannello comandi / Control panel / Bedienblende / Tableau de commande / Panel de mandos
23	4D14513007	Cavo flat scheda-pannello / Flat cable motherboard-control panel / Flat Kabel Hauptplatine-Bedienblende / Câble flat carte mère-panneau commande / Cable flat tarjeta madre-panel de mandos
24	4D14513009	Pressostato / Pressure switch / Druckwächter / Pressostat / Presostato