

# FIRA01.99

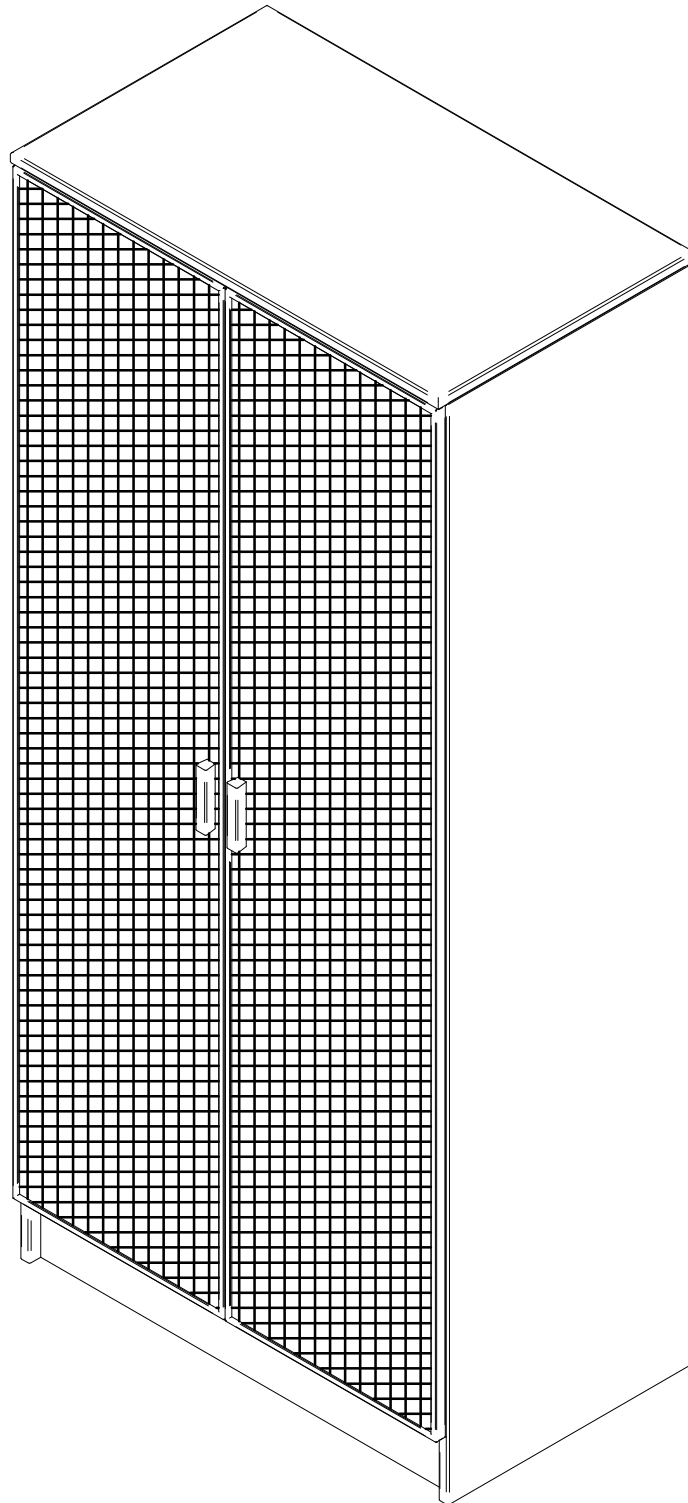

**ASTIGARRAGA**  
*kit line*

FR MONTAGE ES MONTAJE IT MONTAGGIO  
DE BEDIENUNGSANLEITUNG EN ASSEMBLY PT MONTAGEM

FR NOUS VOUS CONSEILLONS

- Poser les colis en position horizontale
- Classer et compter les éléments de montage et la quincaillerie
- Définir une zone de montage
- Suivre dans l'ordre les instructions de montage

DE WIR RATEN IHNEN

- Legen Sie das Paket in eine horizontale Position, bevor Sie es öffnen
- Ordnen und zählen Sie die Teile und Beschläge
- Richten Sie einen Platz für die Montage ein
- Folgen Sie die Montageanleitung Schritt für Schritt

ES TE ACONSEJAMOS

- Poner el paquete en posición horizontal
- Ordenar y contar las piezas y herrajes
- Habilita una zona para el montaje
- Sigue paso a paso las instrucciones de montaje

EN I ADVISE YOU

- Put the package in horizontal position
- Put in the order and count the pieces and iron fittings
- Take enough space for assembly
- Follow step by step the assembly instruction

IT VI INFORMIAMO

- Porre la confezione in orizzontale
- Mettere in ordine e contare le minuterie metaliche
- Essere certi di avere spazio a per il montaggio
- Seguire passo passo le istruzioni

PT ACONSELHAMO-LO A

- Colocar a embalagem na horizontal
- Ordenar e contar as peças e acessórios
- Preparar um local para a montagem
- Seguir passo a passo as instruções de montagem

FR Outils de montage nécessaires (not inclus dans le kit)

DE Erforderliches Werkzeug (nicht im Bausatz enthalten)

ES Las herramientas que necesitas (no incluidas en el kit)

EN The tools that you need for assembly (not included in the package)

IT Gli attrezzi che vi servono per il montaggio (non inclusi nella confezione)

PT As ferramentas de que necessita (não incluídas no kit)

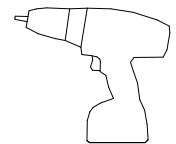
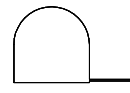
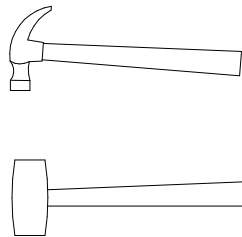
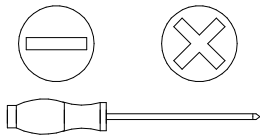

FR Quincaillerie incluse dans le kit

DE Die Beschläge, die Sie im Bausatz finden

ES Los herrajes que encontrarás en el kit

EN The tools that you will find in the package

IT Accessori inclusi nella confezione

PT Os acessórios que encontrará no kit

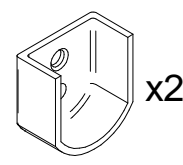
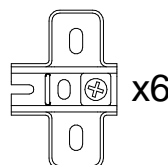
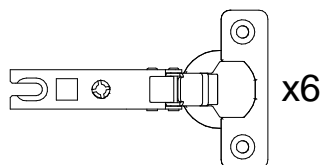
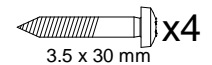
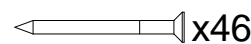
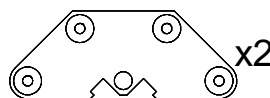
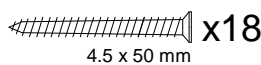
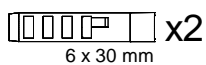
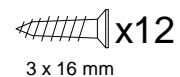
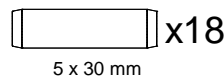
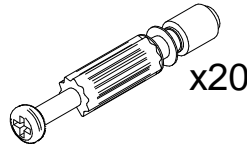
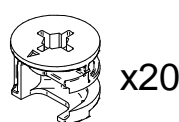

(FR) Pièces incluses dans le kit

(ES) Las piezas incluidas en el kit

(IT) Parti incluse nella confezione

(DE) Die im Bausatz enthalten Teile

(EN) The pieces included in the package

(PT) Peças incluídas no kit

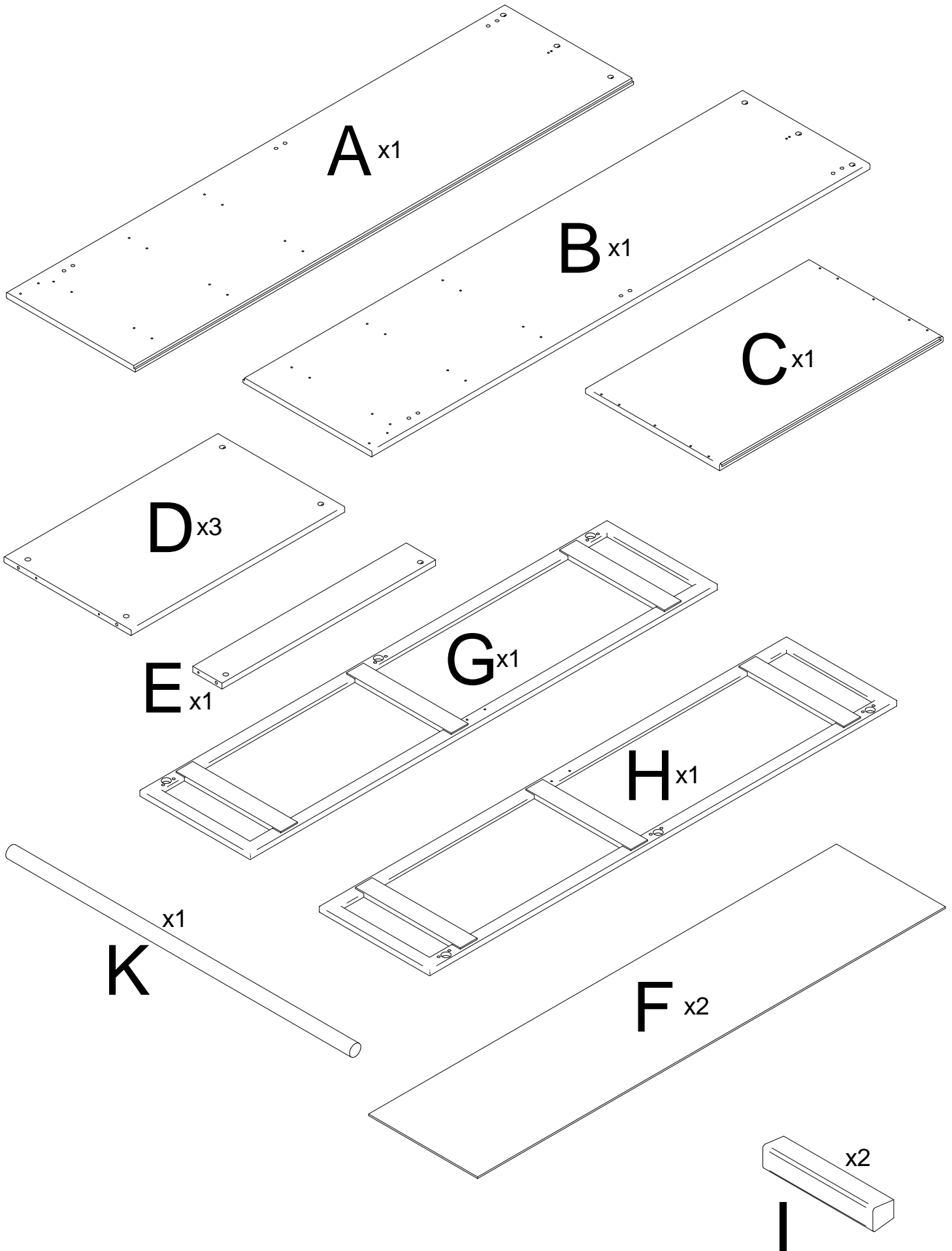

# 1

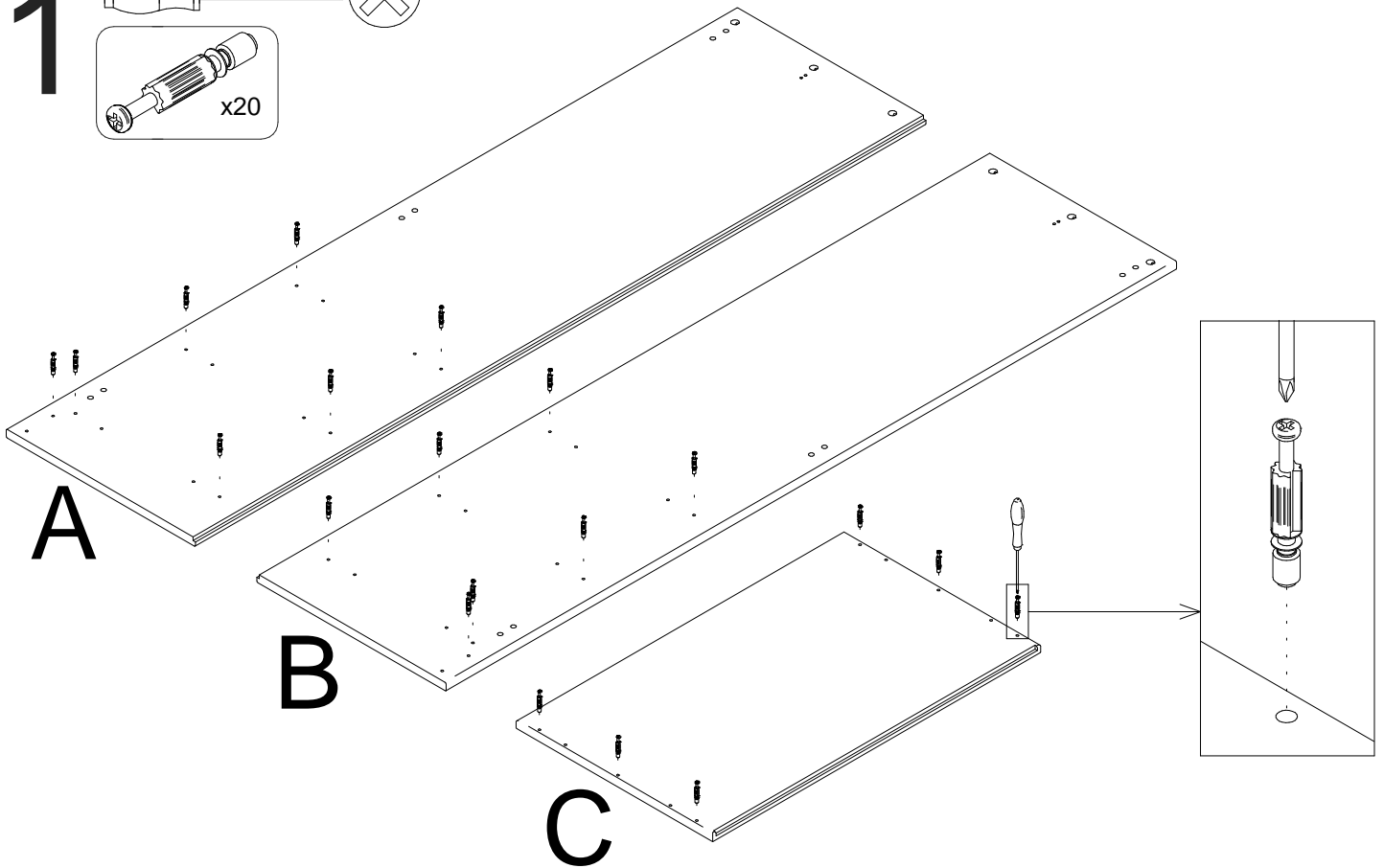
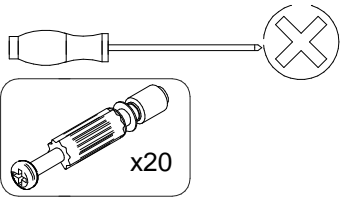

# 2

- Faites attention à l'orientation de la charnière. Voir l'image.
- Atención con la orientación de la bisagra. Ver imagen.
- Prestare attenzione all'orientamento della cerniera. Vedere l'immagine.
- Achten Sie auf Ausrichtung des Scharniers. Siehe Abbildung.
- Pay attention to the orientation of the hinge. See image.
- Prestar atenção à orientação da dobradiça. Ver imagen.

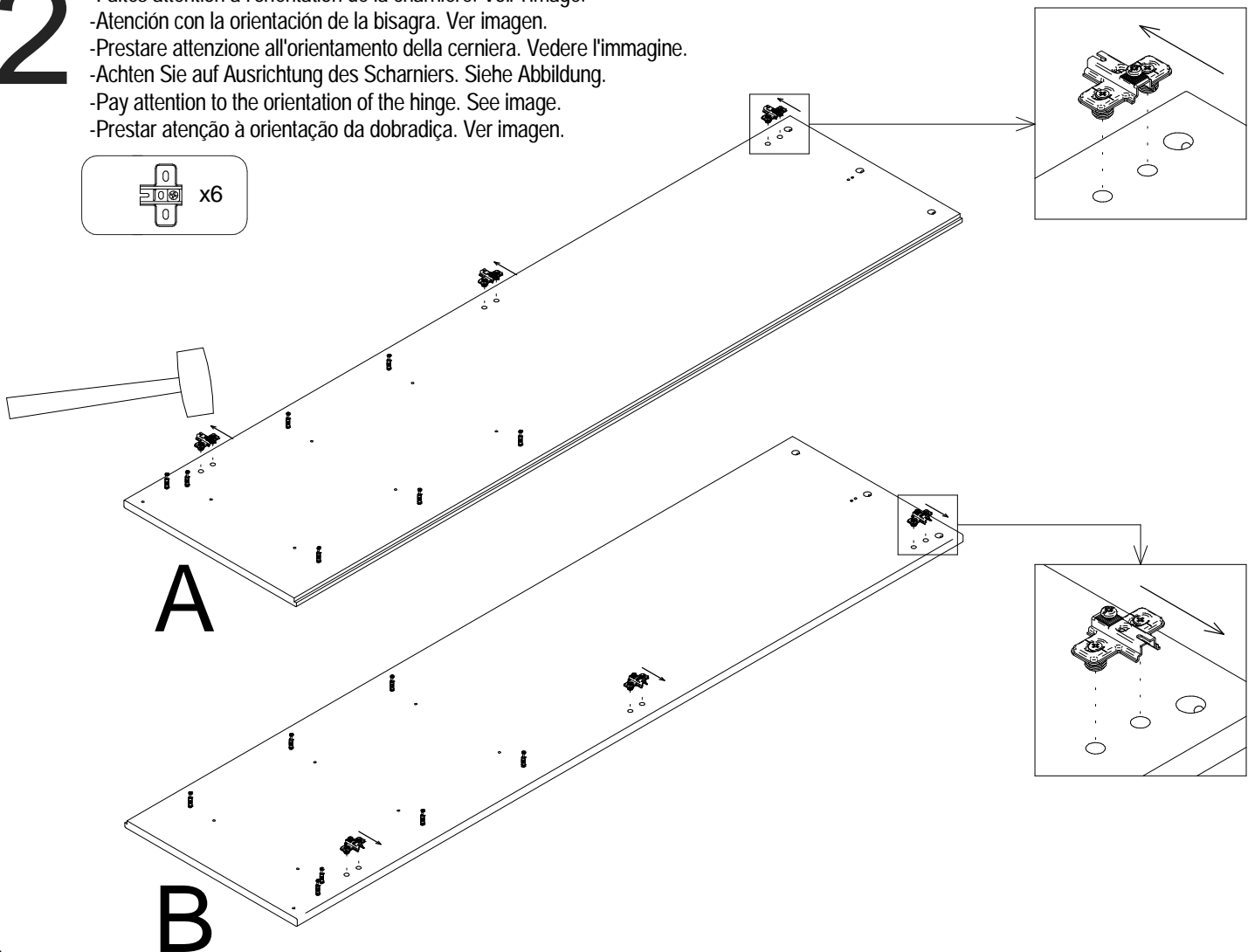
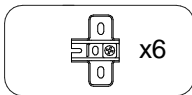

# 3

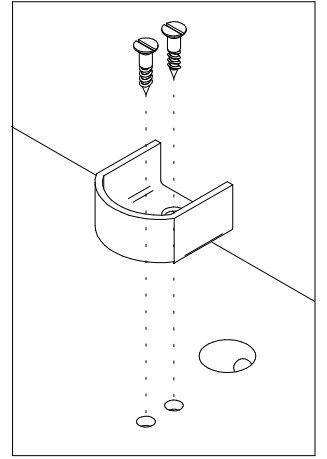
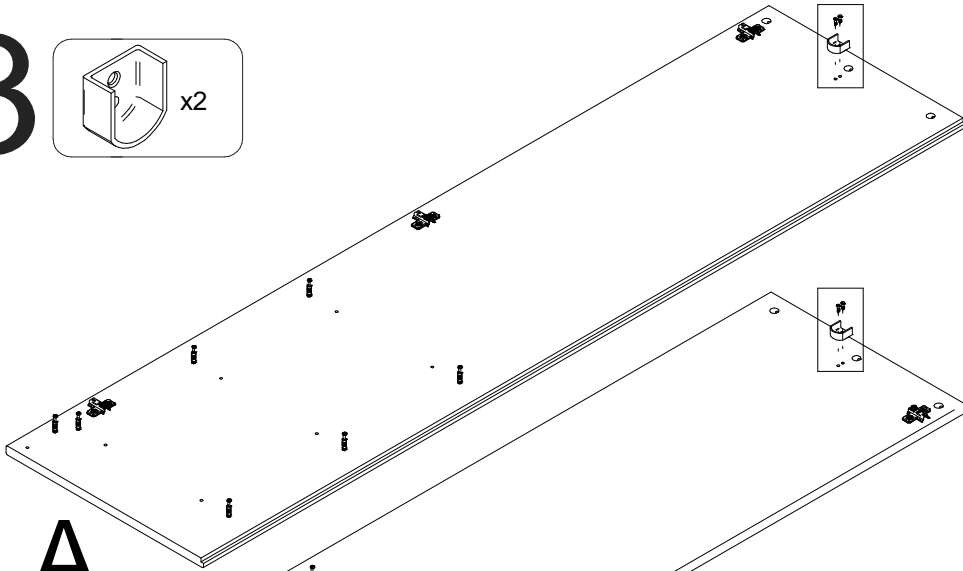
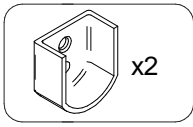

# A

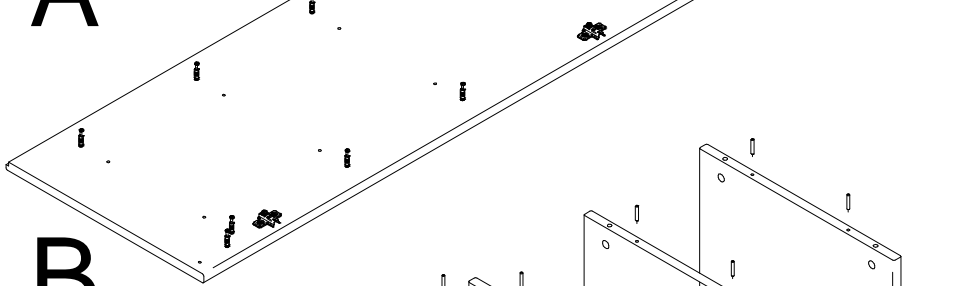

# B

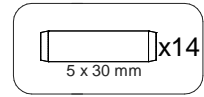

# 4

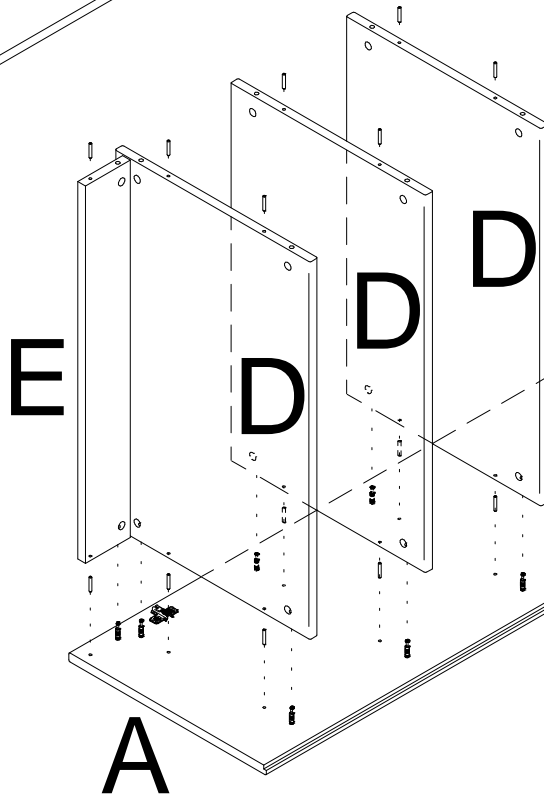

# E

# D

# D

# D

# A

# 5

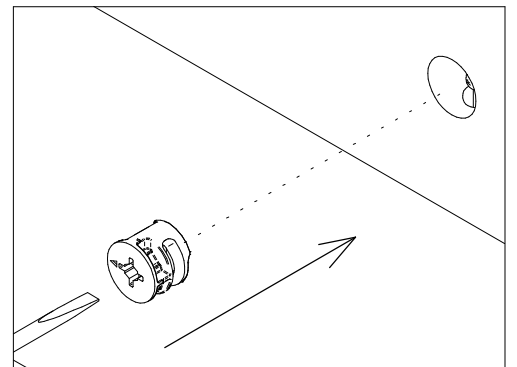
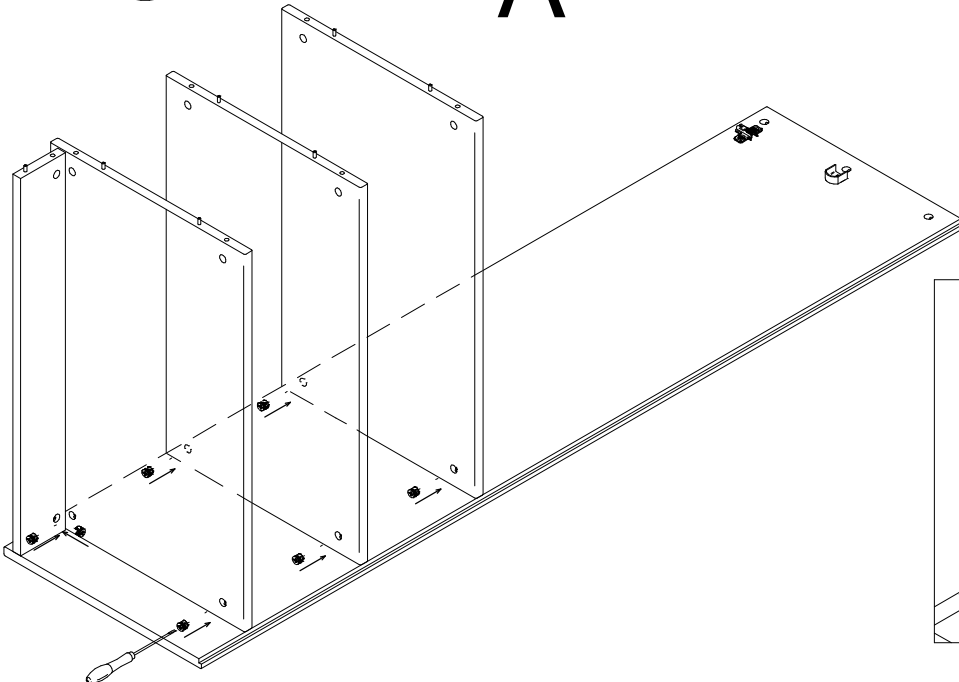
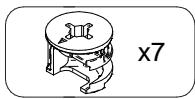

6

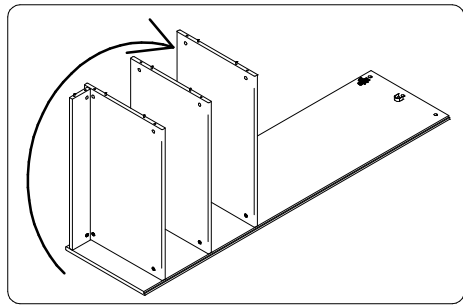

7

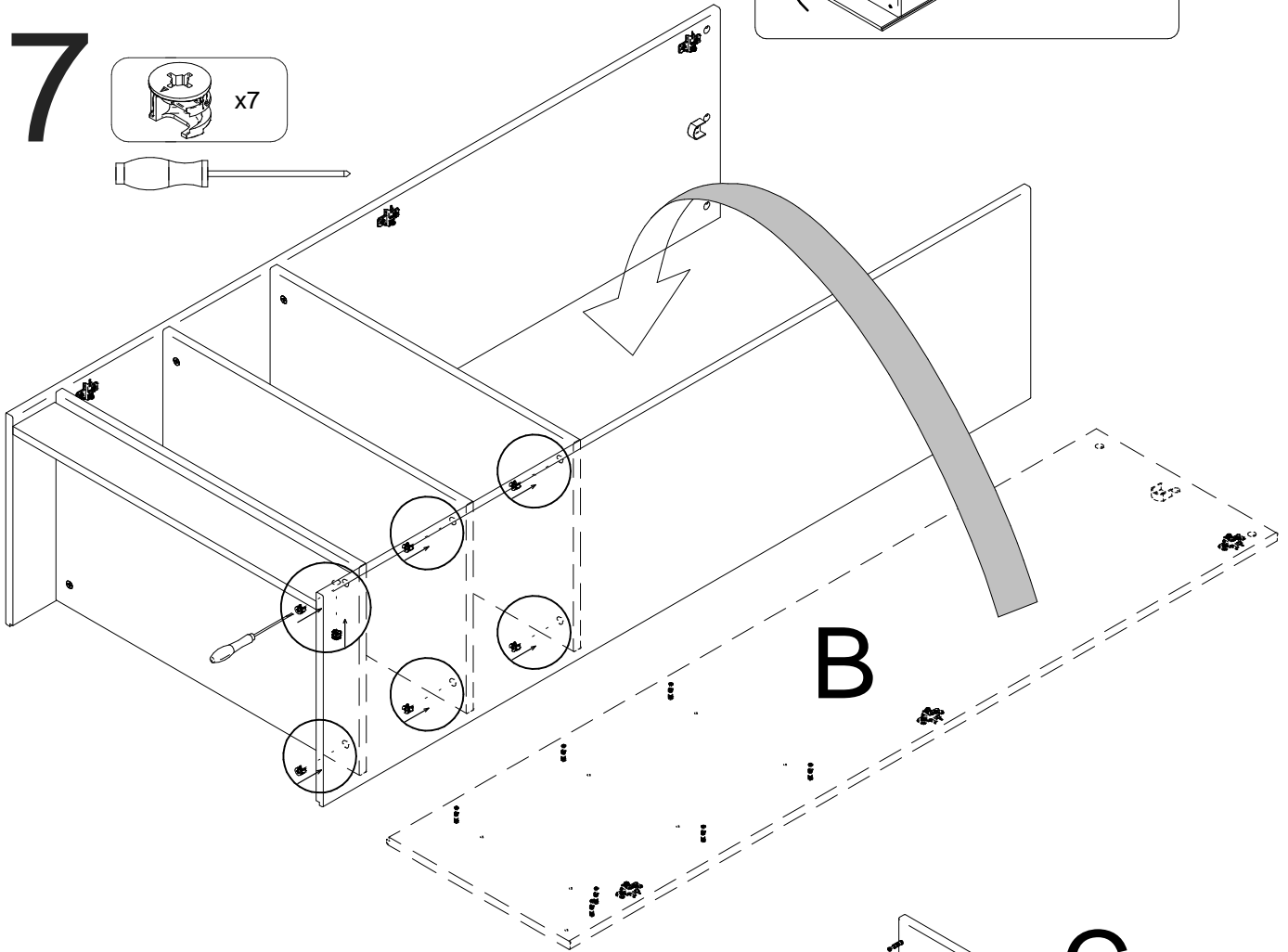
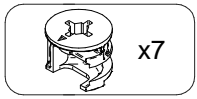

B

8

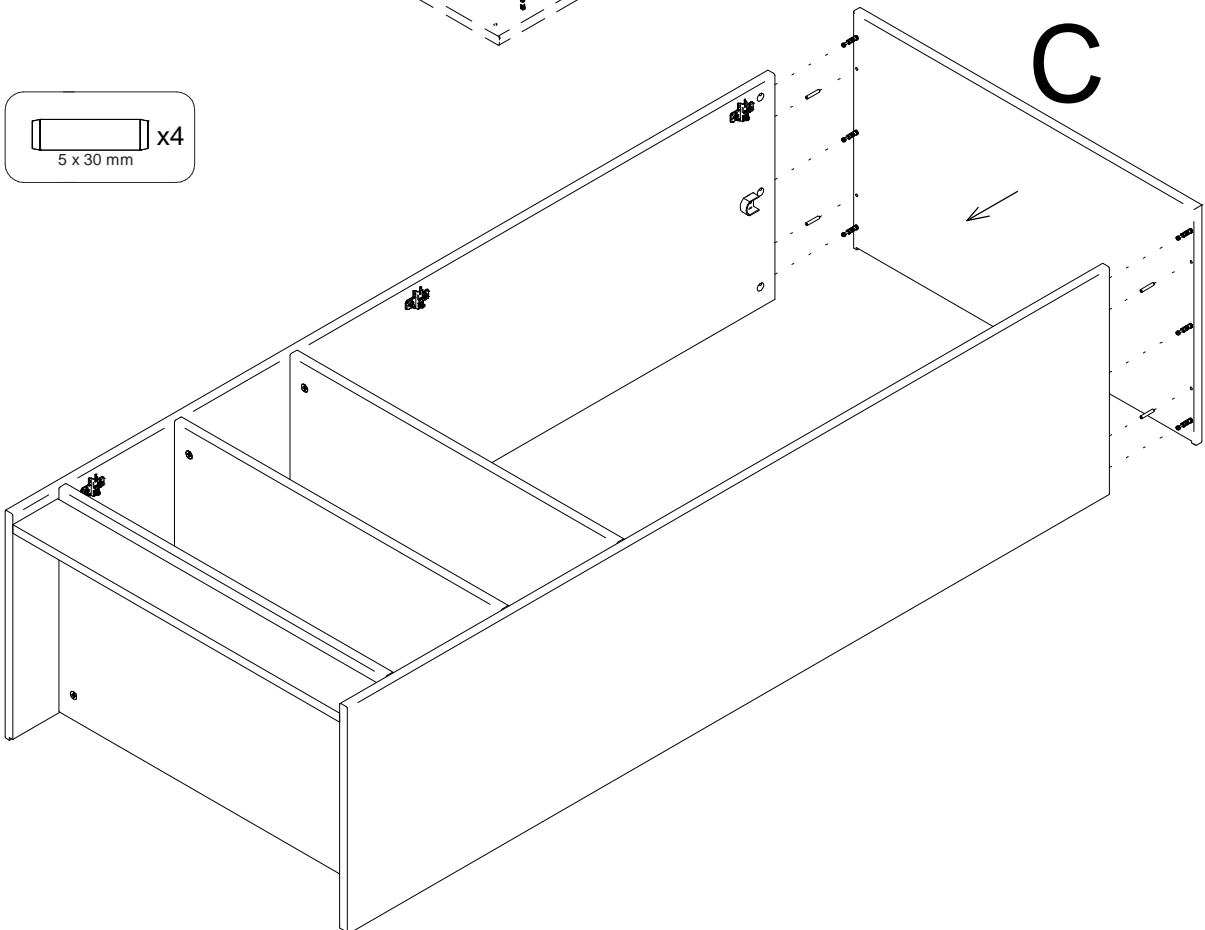
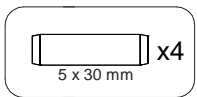

C

# 9

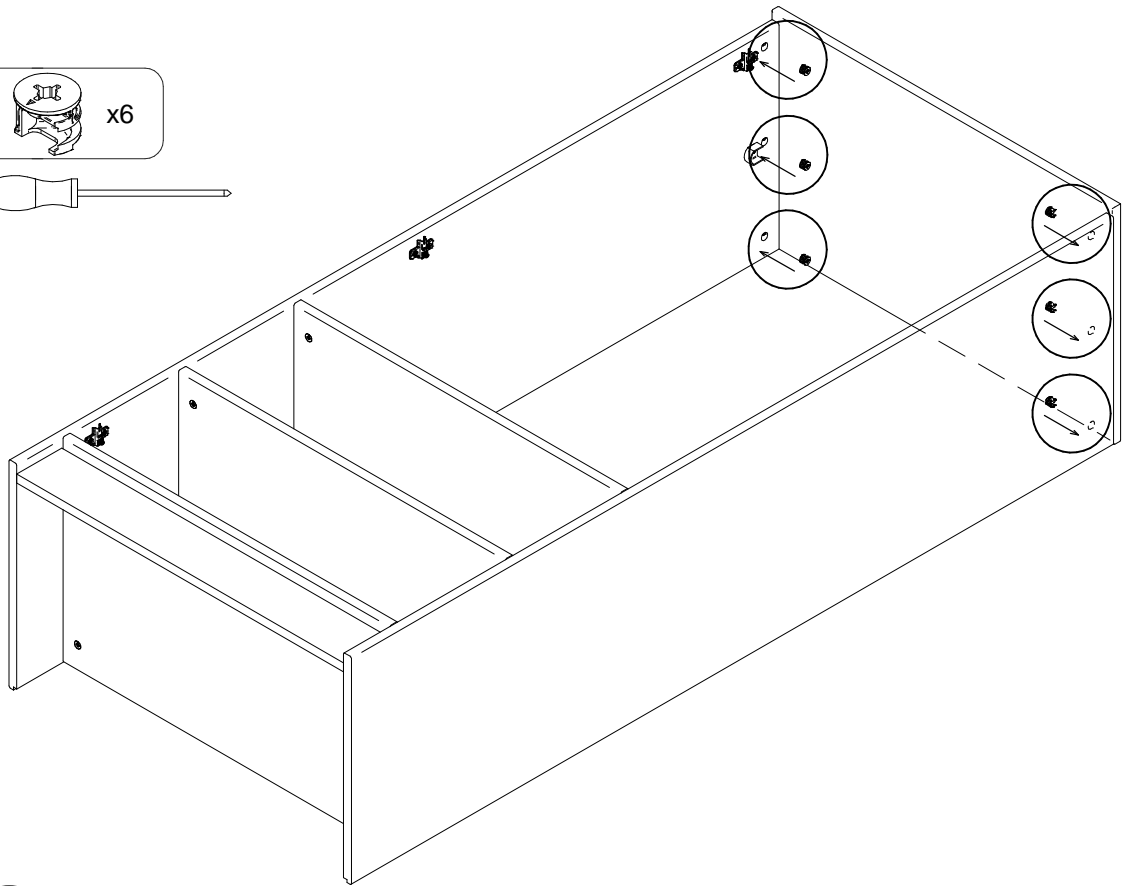
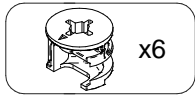

# 10

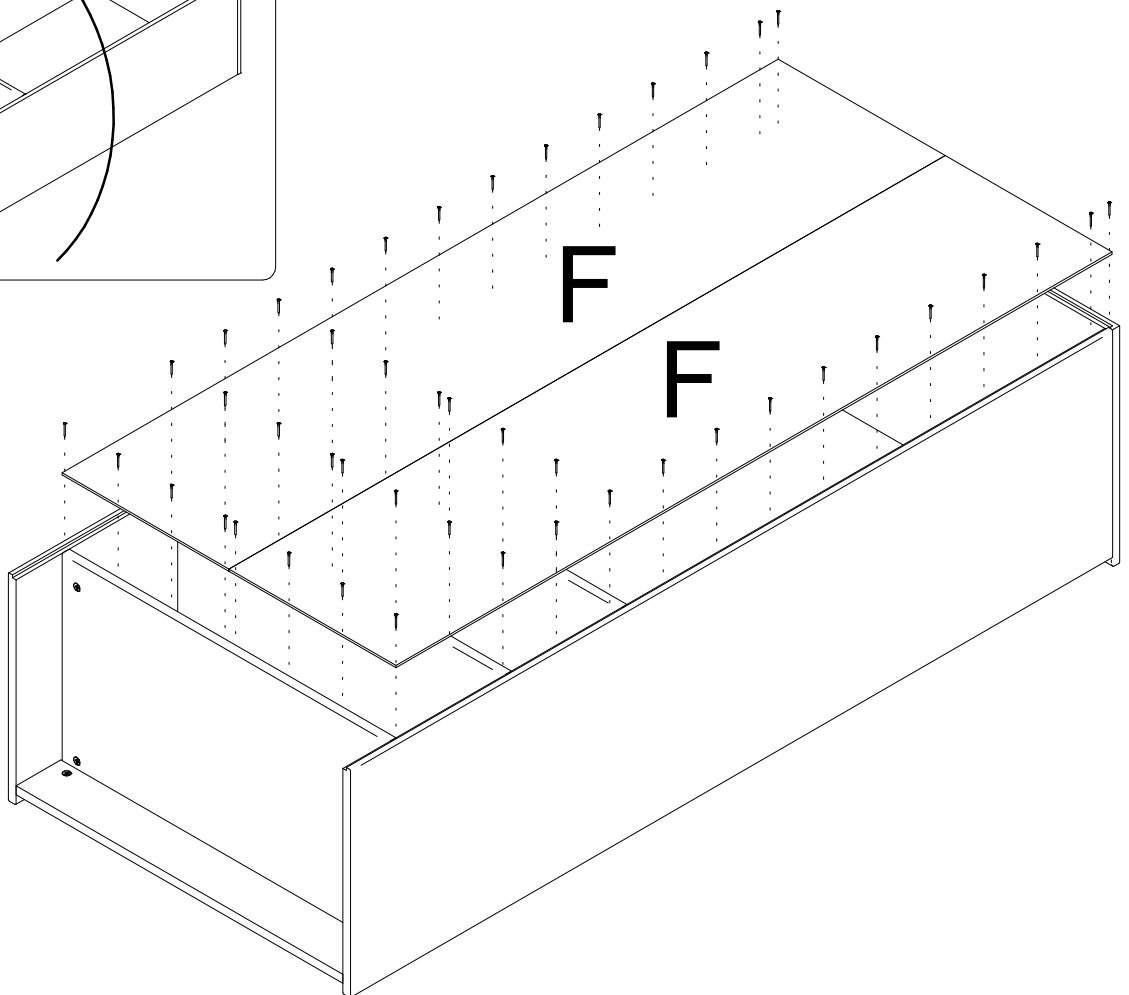
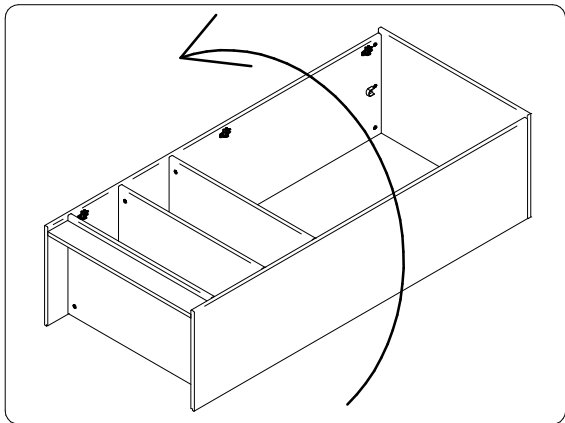
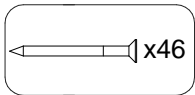

# 11

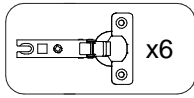

- Faites attention à l'orientation de la charnière. Voir l'image.
- Atención con la orientación de la bisagra. Ver imagen.
- Prestare attenzione all'orientamento della cerniera. Vedere l'immagine.
- Achten Sie auf Ausrichtung des Scharniers. Siehe Abbildung.
- Pay attention to the orientation of the hinge. See image.
- Prestar atenção à orientação da dobradiça. Ver imagen.

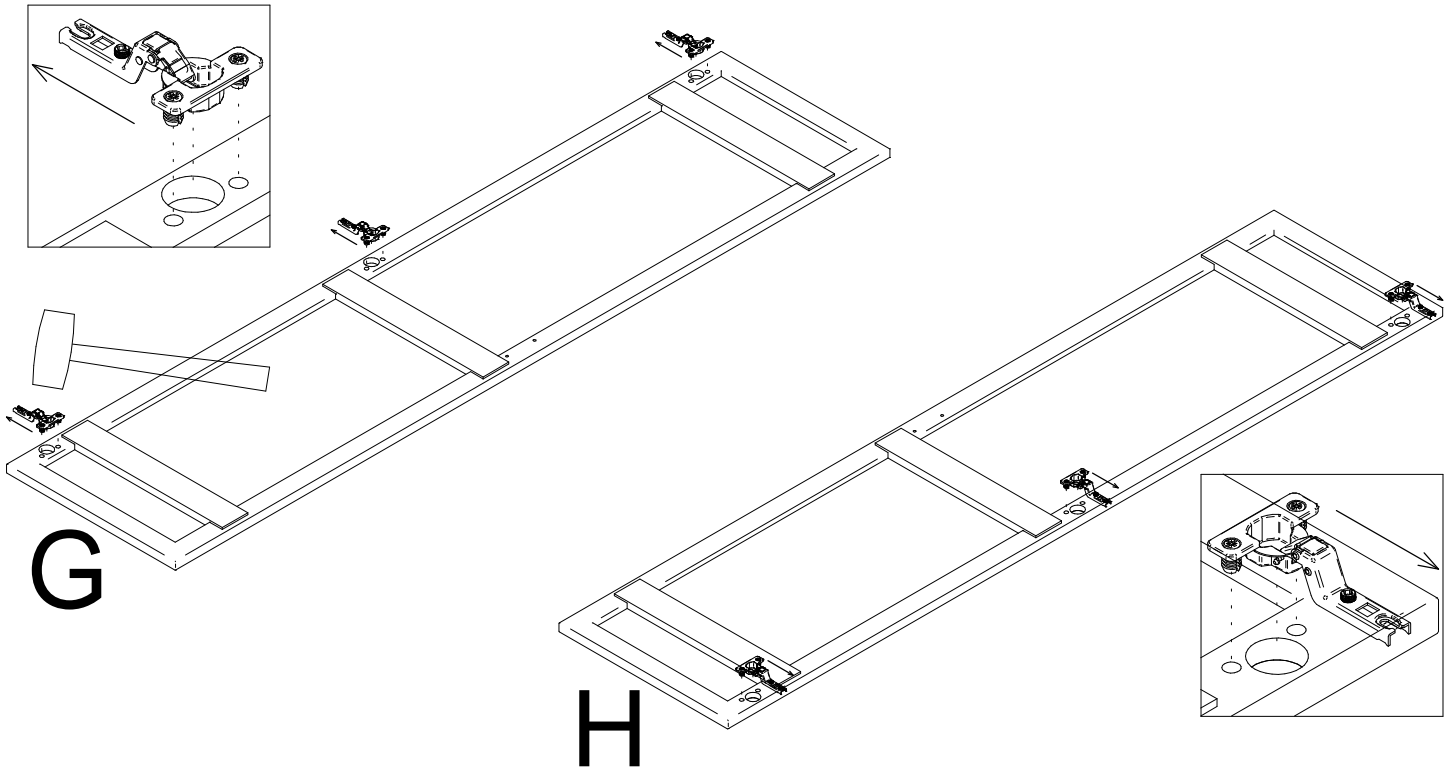

# 12

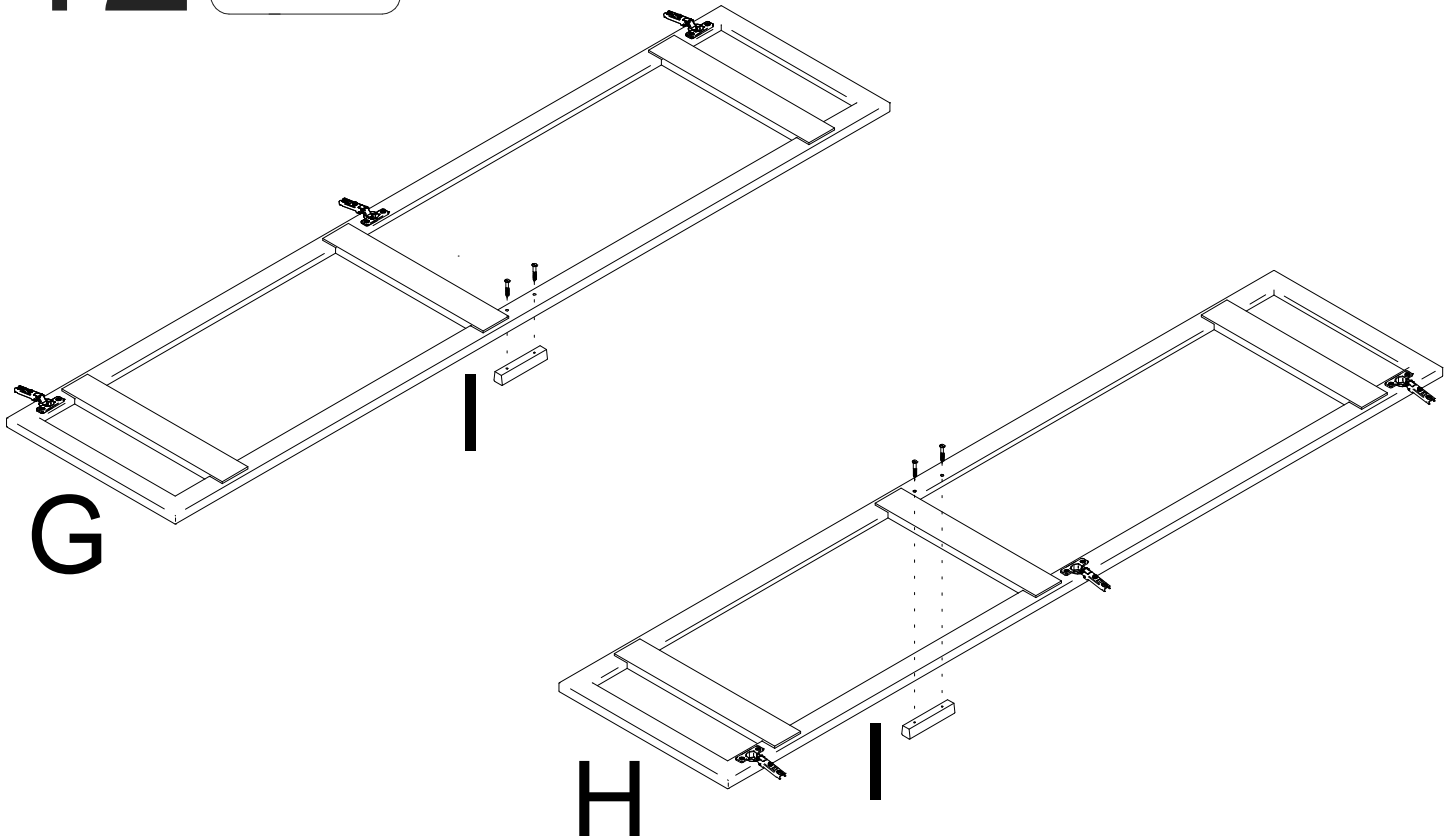
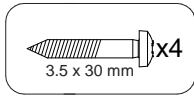

14

K

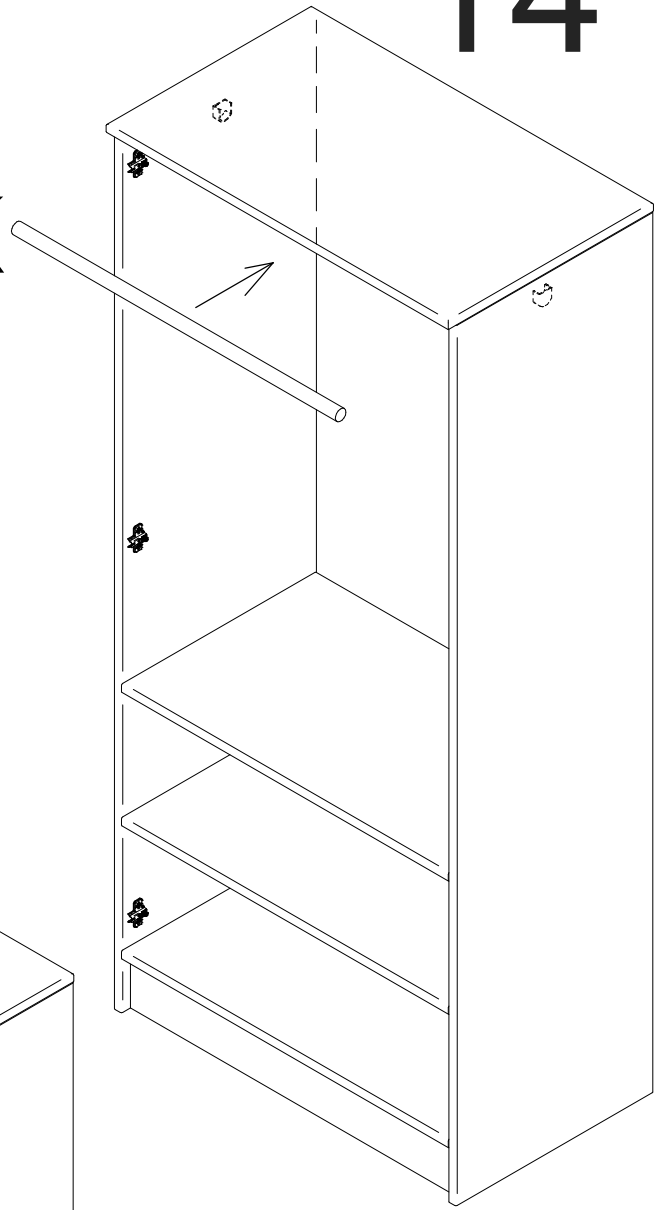

15

G

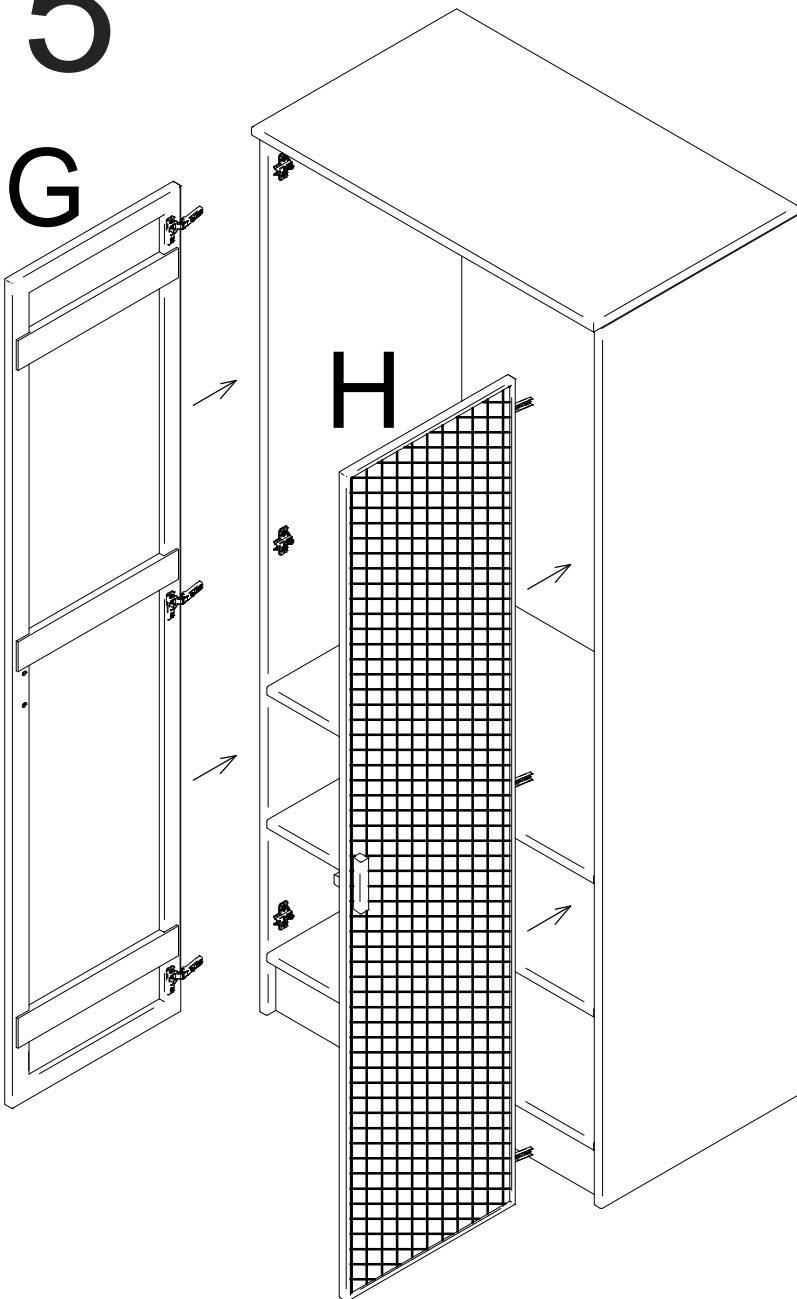

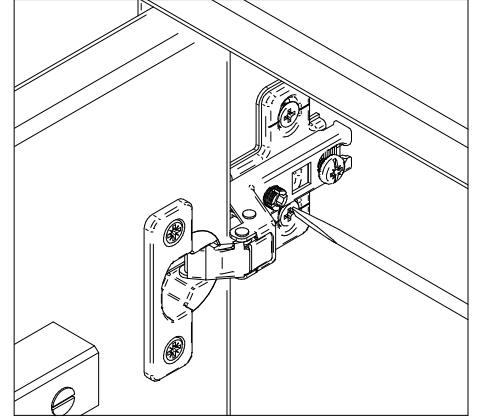
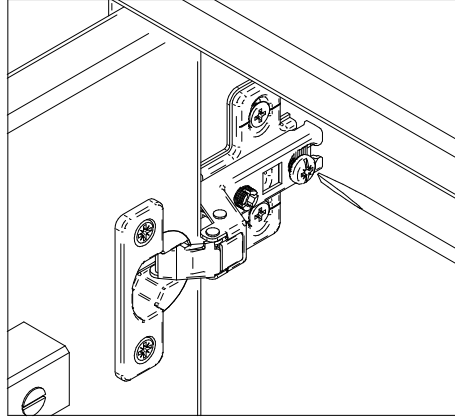
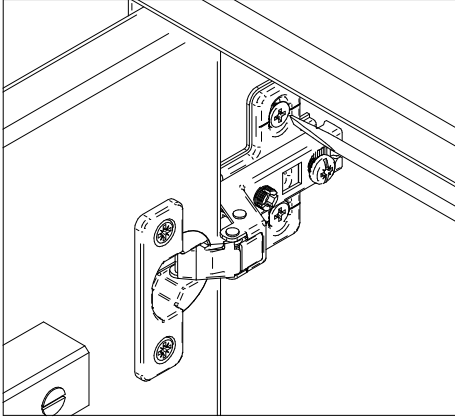
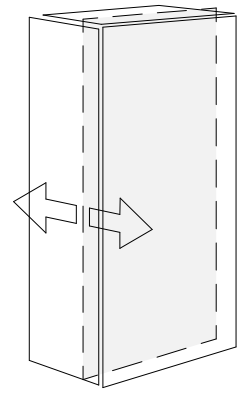
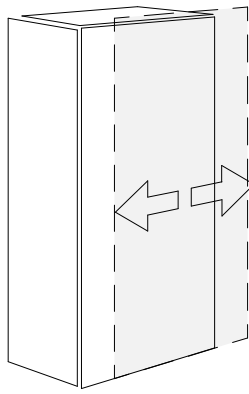
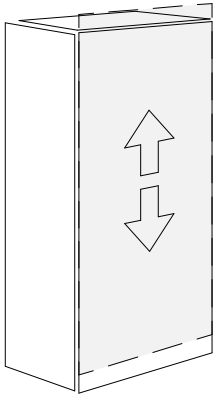

# 16

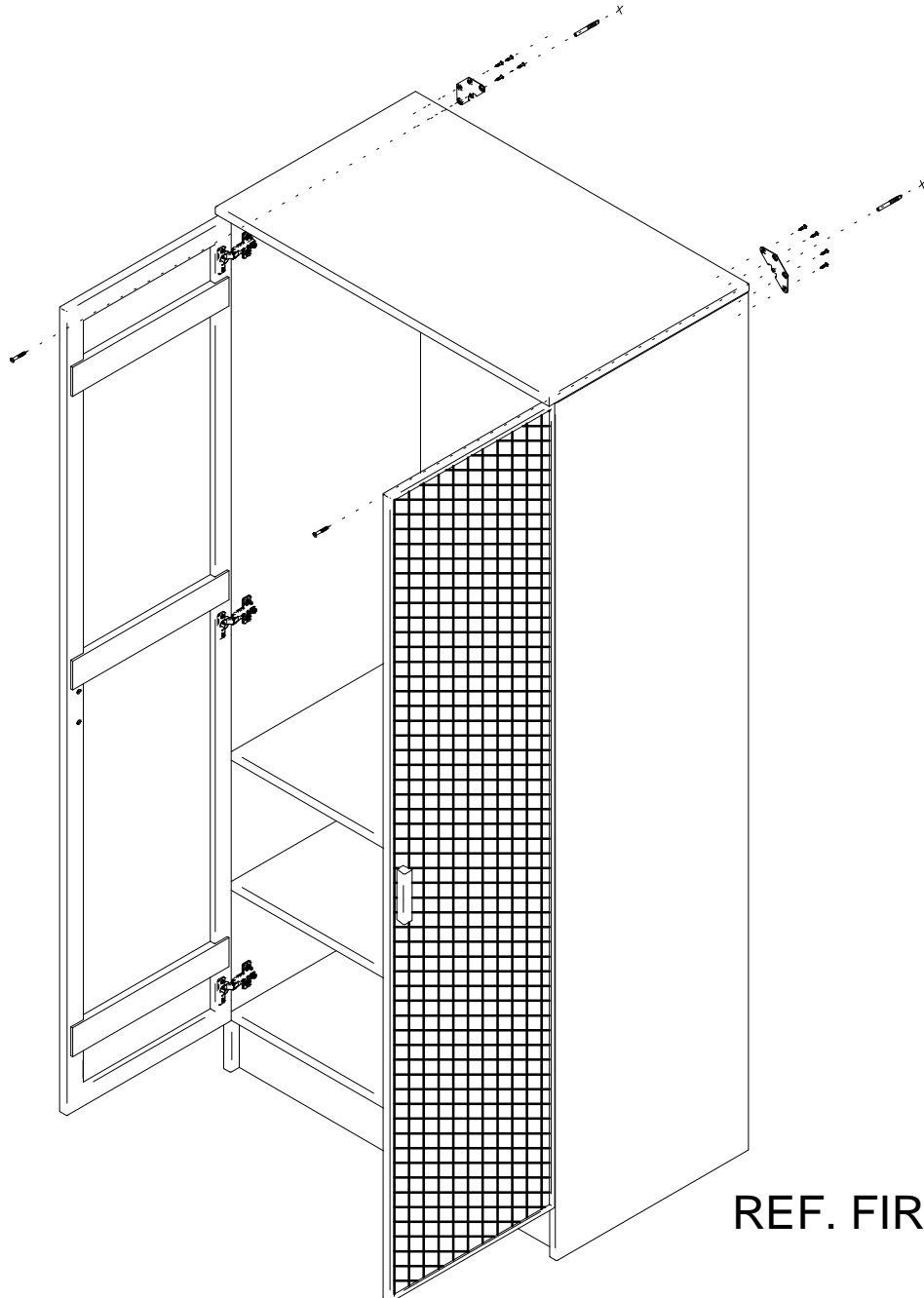
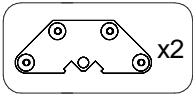
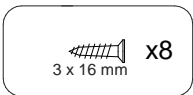
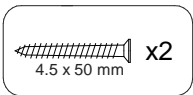
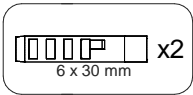

REF. FIRA01.99

- Ⓡ RECOMMANDATIONS D'UTILISATION ET GARANTIE
- Ⓢ RECOMENDACIONES DE USO Y GARANTÍA
- Ⓣ RACCOMANDAZIONI PER L'USO E LA GARANZIA
- Ⓤ EMPFEHLUNGEN ZUR VERWENDUNG UND GARANTIE
- Ⓥ RECOMMENDATIONS FOR USE AND WARRANTY
- Ⓦ RECOMENDAÇÕES DE UTILIZAÇÃO E GARANTIA



Ⓡ AVERTISSEMENT!

Cette étagère doit être fixée au mur à l'aide du matériel de fixation fourni. Les vis et chevilles fournies ne peuvent être utilisées que sur des murs en briques. Utilisez des vis et des chevilles adaptées à vos murs. En cas de doute, demandez l'avis d'un professionnel.

Ⓢ ¡ADVERTENCIA!

Este estantería se debe unir a la pared con los herrajes de fijación a pared que se incluyen. Se incluyen tornillos y tacos de pared únicamente utilizables en paredes de ladrillo. Utiliza tornillos y tacos adecuados para tus paredes. En caso de duda, busca asesoramiento profesional.

Ⓣ ATTENZIONE!

Questo scaffale deve essere fissato alla parete utilizzando la ferramenta per il fissaggio a muro in dotazione. Le viti e i tasselli sono inclusi e possono essere utilizzati solo su pareti in mattoni. Utilizzare viti e tasselli adatti alle proprie pareti. In caso di dubbio, rivolgersi a un professionista.

Ⓤ WARNUNG!

Dieses Regale muss mit dem mitgelieferten Befestigungsmaterial an der Wand befestigt werden. Die mitgelieferten Schrauben und Dübel sind nur für die Verwendung in Ziegelwänden geeignet. Verwenden Sie Schrauben und Dübel, die für Ihre Wände geeignet sind. Lassen Sie sich im Zweifelsfall von einem Fachmann beraten.

Ⓥ WARNING!

This shelf must be attached to the wall using the wall fixing hardware provided. Screws and wall plugs are included and can only be used on brick walls. Use screws and wall plugs suitable for your walls. If in doubt, seek professional advice.

Ⓦ ATENÇÃO!

Esta estante tem de ser fixada à parede utilizando o material de fixação à parede fornecido. Os parafusos e as buchas estão incluídos e só podem ser utilizados em paredes de tijolo. Utilize parafusos e buchas adequados às suas paredes. Em caso de dúvida, procure aconselhamento profissional..



Olalde Area N°3  
20730 Azpeitia (Gipuzkoa)  
Tel. +34 943 814 261 - Fax +34 943 816 713  
info@astikitline.es  
www.astikitline.com

