

DE

WPChaus

EN

Garden shed

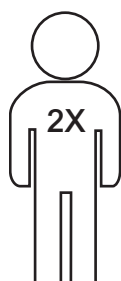

33131465
BAHAG AG
Gutenbergstr. 21
68167 Mannheim
Germany
service@bauhaus.info

Content

DE	WICHTIGE SICHERHEITSHINWEISE.....	3-6
EN	IMPORTANT SAFEGUARDS.....	7-10

WICHTIGE SICHERHEITSHINWEISE



Lesen Sie diese Bedienungsanleitung sorgfältig und bewahren Sie sie zum späteren Gebrauch auf. Fügen Sie diese Bedienungsanleitung bei, wenn Sie dieses Produkt an Dritte weitergeben.

Wenn Sie das Produkt nutzen, sollten Sie immer grundlegende Sicherheitsvorkehrungen treffen, um das Risiko von Verletzungen zu reduzieren, wozu auch Folgendes gehört:

⚠️ WARNUNG – Verletzungsrisiko!

- Die Produktverpackung umfasst Kleinteile, scharfe Kanten und scharfe Spitzen. Halten Sie Kinder und Haustiere während der Montage fern.
- Bauen Sie das Produkt an einem trockenen und windstillen Tag zusammen. Versuchen Sie nicht, die Montage bei starkem Wind oder extremen Wetterbedingungen durchzuführen.
- Treffen Sie besondere Vorsichtsmaßnahmen, wenn Sie in der Höhe arbeiten, z. B. bei Nutzung einer Leiter. Nutzen Sie eine geeignete Leiter und vergewissern Sie sich, dass die Leiter stabil und standsicher ist. Verwenden Sie die Leiter gemäß den Anweisungen des Herstellers.
- Verwenden Sie den Bohrschrauber ordnungsgemäß und gemäß den Anweisungen des Herstellers.
- Zum Schutz vor Verletzungen und Sachschäden durch starken Wind muss das Produkt fest auf einem geeigneten Basis-Fundament verankert werden.
- Bestimmungsgemäßer Gebrauch: Das Metallhaus ist zur Lagerung von Gartengeräten und Fahrrädern geeignet. Das Metallhaus ist nicht zur Lagerung von Gefahrstoffen oder zur Unterbringung von Personen oder Tieren geeignet.

⚠️ VORSICHT – Verletzungsrisiko!

	<p>Scharfe Kanten! Gehen Sie vorsichtig vor.</p>		<p>Tragen Sie eine Schutzbrille.</p>
	<p>Tragen Sie schwere Schutzhandschuhe.</p>		<p>Tragen Sie Sicherheitsschuhe.</p>
	<p>Tragen Sie Schutzkleidung.</p>		

Empfohlene Werkzeuge

		<p>φ 2.5mm</p> <p>φ 3mm</p>	<p>12mm</p>	

- Beachten und befolgen Sie alle örtlichen Bauvorschriften. Beantragen Sie gegebenenfalls eine Genehmigung der örtlichen Behörden. Erkundigen Sie sich immer bei Ihren örtlichen Behörden, um sicherzustellen, dass Ihre Metallhaus den Vorschriften entspricht.
- Lassen Sie Kinder nicht auf das Produkt klettern oder in der Nähe des Produktes spielen.
- Bauen Sie das Produkt immer auf einem festen, ebenen Untergrund auf.
- Verwenden Sie dieses Produkt nicht, wenn Teile fehlen, beschädigt oder abgenutzt sind.
- Ziehen Sie die Befestigungselemente nicht übermäßig fest an.
- Der Dachbelag darf nur über eine standfeste Leiter montiert werden. Das Dach darf während des Aufbaus und zum Schneeräumen nicht betreten werden.
- Betreten Sie das Dach NICHT während der Montage oder beim Entfernen von Schnee und/oder Eis.
- Betreten Sie die Dachfläche zu keiner Zeit, um Sturz- und Verletzungsgefahr zu vermeiden.
- Entfernen Sie Schnee- und/oder Eislasten immer sofort, um Schäden am Produkt und mögliche Verletzungen zu vermeiden:
- Gefährliche Schneehöhe: 100 mm oder mehr (entspricht ca. 50 kg/m²: Schichthöhe von 360 mm bei trockenem Schnee; 100 mm bei nassem Schnee; 55 mm bei Eis).
- Halten Sie den Türbereich immer frei. Benutzen Sie im Notfall oder bei Feuer immer den Ausgang durch die Tür.

Vor der Montage

⚠ GEFAHR – Erstickungsrisiko!

Halten Sie Verpackungsmaterialien von Kindern und Haustieren fern – diese Materialien stellen eine potenzielle Gefahrenquelle dar, z. B. Ersticken.

- Das Produkt wird in zwei separaten Kartons geliefert. Detaillierte Information finden Sie im Kapitel „Teileliste“ und in den Tabellen 1 (Karton 1) und 2 (Karton 2). In den drei Spalten der jeweiligen Tabelle sind Teilenummer, Zeichnung und Menge angegeben.
- Entfernen Sie alle Verpackungsmaterialien.
- Entnehmen und überprüfen Sie alle Komponenten, bevor Sie mit der Montage beginnen.
- Legen Sie alle Komponenten auf ein Tuch oder eine Kunststoffolie, um Beschädigungen zu vermeiden.
- Ordnen Sie alle Komponenten nach den Teilenummern, die auf jeder Komponente angegeben sind.
- Überprüfen Sie alle Komponenten auf Transportschäden.
- Bereiten Sie Ihre persönliche Schutzausrüstung (PSA) und alle für die Montage erforderlichen Werkzeuge vor.

Auswahl des Standortes

VORSICHT

- Das Produkt muss auf einem soliden Basis-Fundament, beispielsweise einer Betonplatte oder behandeltem Holz, verankert werden.
- Bauen Sie das Produkt nicht direkt auf weichem Untergrund wie Rasen, Erde oder Kies auf. Für ein geeignetes Basis-Fundament auf Beton- oder Holzbasis wenden Sie sich an einen autorisierten örtlichen Bauhändler.

i Hinweis

- Wählen Sie einen Standort, der ausreichend Platz zum Arbeiten rund um das Produkt lässt.
- Achten Sie darauf, dass der Standort fest und eben ist, ohne Wurzeln oder Steinbrocken.
- Der Basis-Rahmen muss flach am Boden aufliegen. Nivellieren Sie den Basis-Rahmen mit einer Wasserwaage.
- Vermeiden Sie Standorte mit tief hängenden Ästen, da schwere Äste herunterfallen und das Produkt beschädigen könnten.
- Vermeiden Sie die Montage des Produktes in einem niedrigen Bereich, in dem sich Wasser sammelt, oder der am Fuße eines Hügels liegt.
- Kleine Bäume, Büsche oder Zäune rund um das Produkt, können als Windschutz hilfreich sein.
- Wenn Betonplatten verwendet werden, ist es wichtig, dass sie zu den Rändern hin geneigt sind, um das Ansammeln von Wasser zu vermeiden.
- Planen Sie voraus. Wenn Betonplatten verwendet werden, muss der Beton vor der Montage ausreichend trocknen.
- Achten Sie darauf, nicht an den Stellen im Boden zu graben, wo Wasser-, Gas- oder Elektroleitungen liegen.
- Vermeiden Sie es, das Produkt in der Nähe einer Klärgrube zu positionieren, falls eine solche in der Nähe vorhanden ist.
- Wenn Sie einen Bohrschrauber verwenden, stellen Sie das Drehmoment auf #4 ein, um sicherzustellen, dass die Schrauben die Metallverstärkungen nicht abtragen.

Basis-Fundament

i Hinweis

- Das Basis-Fundament sollte mindestens 10 cm dick sein.
- Das Basis-Fundament sollte mindestens 10 cm größer sein als die Produktabmessungen.

Empfohlener Mindestabstand für den Bau des Basis-Fundaments.

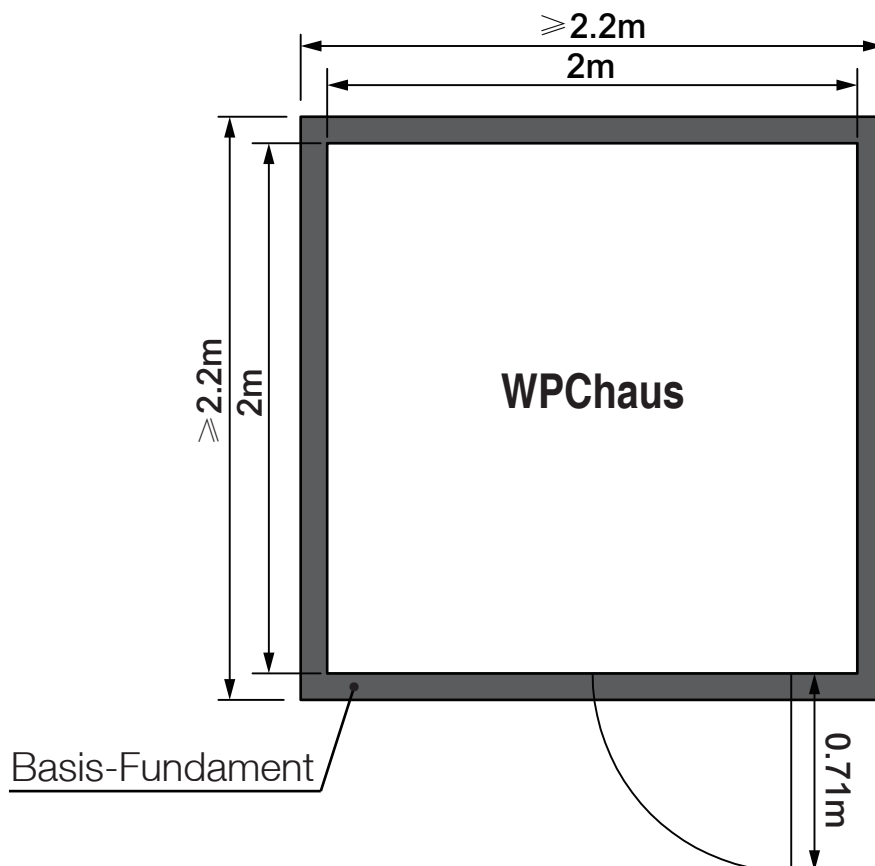

Montageanleitung

- Lesen Sie alle Anweisungen durch, bevor Sie mit der Montage beginnen.
- Folgen Sie bei der Montage sorgfältig den bebilderten Montageschritten und stellen Sie sicher, dass Sie diese vollständig verstanden haben. Wenden Sie sich im Zweifelsfall an einen Fachmann.
- Planen Sie voraus und nehmen Sie sich genügend Zeit für die Montage. Durch Eile werden häufig Fehler und unnötige Verletzungen verursacht. Wenn Sie noch nie eine Hütte aufgebaut haben, nehmen Sie sich Zeit. Je nach Ihrer Erfahrung und der verfügbaren Hilfe kann die Montage etwas mehr Zeit in Anspruch nehmen.

Reinigung

Hinweis

Verwenden Sie nie ätzende Reinigungsmittel, Drahtbürsten, Scheuermittel oder metallische oder scharfe Utensilien, um das Produkt zu reinigen.

- Nutzen Sie einen Gartenschlauch, um die Außenverkleidung des Metallhauses abzuspülen.
- Schrubben Sie den verbleibenden Schmutz mit einem Tuch mit mildem Reinigungsmittel und Wasser ab.
- Fegen Sie das Innere des Metallhauses mit einem Besen aus. Sie können auch einen Laubbläser dazu nutzen, den gesamten Schmutz wegzublasen.
- Um Schimmel zu beseitigen, tränken Sie ein Tuch in mildem Reinigungsmittel und schrubben Sie den Schimmel und Moder ab.
- Um Baumharz zu entfernen, gießen Sie etwas mildes Reinigungsmittel über das Harz und lassen Sie es gründlich einwirken, bevor Sie es kräftig abschrubben.

Wartung

- WPCHAUS: Überprüfen Sie das Produkt regelmäßig auf Schäden und Abnutzung. Stellen Sie die Nutzung ein, wenn erste Anzeichen von Schäden erkennbar sind oder wenn sich Komponenten lösen.
- DACH: Entfernen Sie Laub und Schnee mit einem langstieligen, weichen Besen. Starker Schnee oder Eis auf dem Dach kann das Metallhaus beschädigen und es unsicher machen. Steigen Sie nicht auf das Dach. Nutzen Sie das Dach nicht als zusätzlichen Stauraum. Überprüfen Sie das Dach regelmäßig auf Beschädigungen.
- WÄNDE: Lehnen Sie keine Gegenstände oder sich selbst gegen die Wandpaneele.
- TÜR: Halten Sie die Tür geschlossen, um Windschäden zu vermeiden.
- TÜRSCHARNIERE: Dies ist der schwächste Punkt des Metallhauses, daher sollten Sie besonders vorsichtig damit umgehen. Die Scharniere können nach einiger Zeit festsitzen, daher sollten sie immer gut geschmiert sein.
- FEUCHTIGKEIT: Bei wechselnden Temperaturen sammelt sich Kondenswasser im Metallhaus. Eine gute Belüftung hilft bei der Regulierung und Vermeidung von Feuchtigkeit. Öffnen Sie die Tür häufig, um für ausreichende Belüftung zu sorgen.
- BEFESTIGUNGSELEMENTE: Überprüfen Sie regelmäßig, ob alle Komponenten und Befestigungselemente fest angezogen sind.

Entsorgung



Entsorgen Sie das Produkt den örtlichen Vorschriften entsprechend. Wenden Sie sich im Zweifelsfall an Ihren kommunalen Entsorger.

Technische

Nettogewicht	290 kg
Abmessungen (T x B x H)	approx. 2 x 2 x 2.18m
Lagerfläche	approx. 4m ²

IMPORTANT SAFEGUARDS





Read these instructions carefully and retain them for future use. If this product is passed to a third party, then these instructions must be included.

When using the product, basic safety precautions should always be followed to reduce the risk of injury including the following:







⚠ WARNING - Risk of Injury!

- The product package contains small parts, sharp edges and sharp points. Keep children and pets away during assembly.
- Assemble on a dry and calm day. Do not attempt to assemble in strong wind or extreme weather.
- Take special precautions when working on heights, for example while using a ladder. Use the right type of ladder and ensure it is structurally sound. Use the ladder in accordance with the manufacturer's instructions.
- Use the drill driver properly and in accordance with the manufacturer's instructions.
- The product must be firmly anchored to a suitable base foundation to protect against injuries and damages caused by high winds.
- Intended use: The shed is suitable for storing garden tools and bicycles. The shed is not suitable for storing hazardous materials or for housing people or animals.

⚠ CAUTION - Risk of Injury!

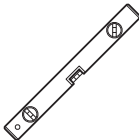
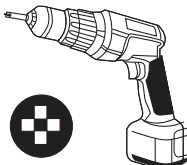
 <p>Sharp edges! Handle with care.</p>	 <p>Wear eye protection.</p>
 <p>Wear heavy duty protective gloves.</p>	 <p>Wear safety footwear.</p>
 <p>Wear protective clothing.</p>	

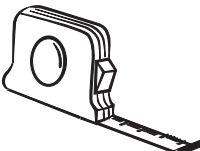
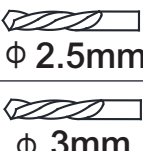
Recommended Tools

				
		 <p>φ 2.5mm</p> <p>φ 3mm</p>	 <p>12mm</p>	

- Observe and follow all the local building ordinances. Apply for permission from local authorities if necessary. Always check with local authorities to ensure your shed is up to code.
- Do not let children climb on or play around the product.
- Always assemble the product on a firm, level ground.
- Do not use this product if any parts are missing, damaged, or worn.
- Do not over-tighten the fasteners.
- The roof covering may only be installed using a stable ladder. The roof may not be entered during assembly and for snow removal.
- Do NOT climb on the roof during assembly and when removing snow and/or ice.
- Do NOT climb on the roof area at any time to prevent danger of falling and injury.
- Always remove snow and/or ice build-up immediately to avoid damaging the product and potentially causing injury:
- Dangerous snow height: 100 mm or more (according to approx. weight of 50 kg/m²: layer height of 360 mm dry snow; 100 mm watery snow; 55 mm ice).
- Always keep the doorway clear. In case of emergency or fire, always use the doorway to exit the shed.

Before assembly

⚠ DANGER - Risk of Suffocation!

Keep any packaging materials away from children and pets – these materials are a potential source of danger, e.g. suffocation.

- The product is delivered in a carton. For detailed information, please refer to “Parts List”.
- Remove all the packing materials.
- Remove and review all components before starting assembly.
- Place all the components on a cloth or plastic sheet to avoid damage.
- Organize all the components according to the part numbers indicated on each component.
- Check all the components for transport damages.
- Prepare all the personal protective equipment (PPE) and all the tools required for assembly.

Selecting location

CAUTION

- The product must be anchored to a solid base foundation, such as concrete slab or treated timber.
- Do not assemble the products on soft ground directly, such as lawn, soil or gravel. For a suitable concrete or wooden base foundation, contact an authorized local building dealer.

i Notice

- Select a location that allows sufficient working space around the product.
- ~~Make sure the location is firm and level without roots or clumps of rocks.~~
- The base frame must lie flat on the ground. Level the base frame using a spirit level.
- Avoid locations with low hanging branches, as heavy branches could fall and damage the product.
- Avoid assembling the product in a low-lying area that collects water or that lies at the bottom of a hill.
- Small trees, bushes or fences around the product can be helpful to act as a windbreak.
- If concrete slab is used, it is important that it slopes towards the edges to prevent water collection.
- Plan in advance. If concrete slab is used, allow sufficient time for the concrete to dry before assembly.
- Be careful not to dig into the ground where water pipes, gas lines, or electrical cables are lying.
- Avoid placing the product anywhere near a septic tank, if present in the vicinity.
- When using a drill driver, set the torque according to the screw specifications to ensure the screws to do not strip the metal reinforcements.

Base foundation

i Notice

- The base foundation should be at least 10 cm thick.
- The base foundation should be at least 10 cm larger than the product dimensions.

Recommended minimum space for construction of the base foundation.

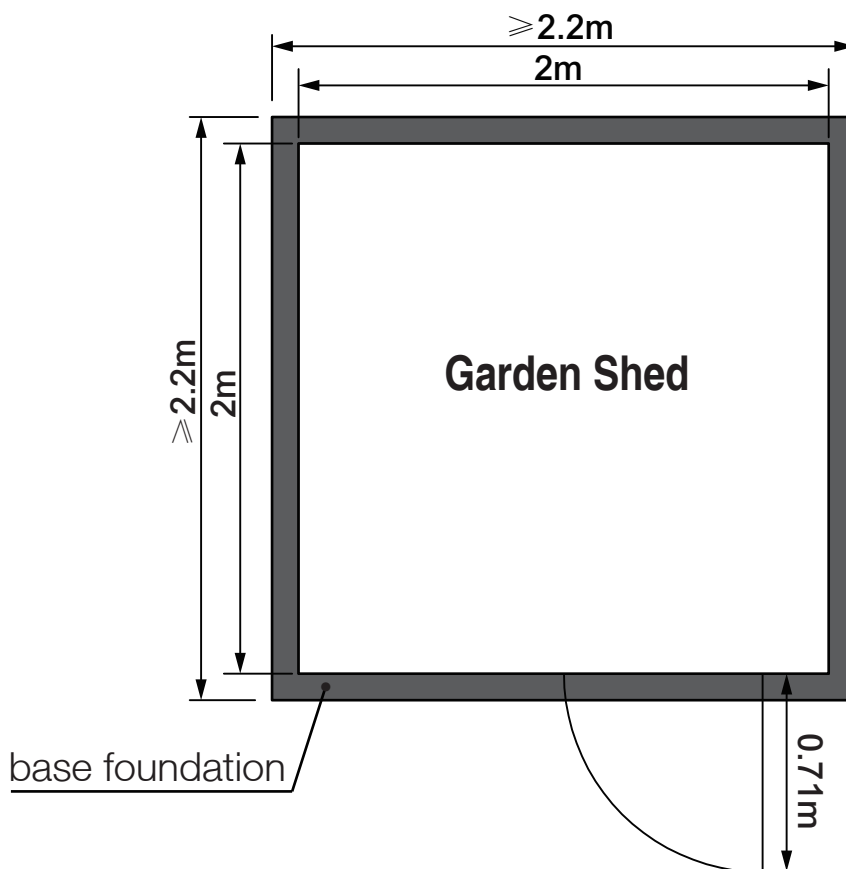

Assembly instructions

- Review all instructions before starting assembly.
- During assembly, carefully follow illustrated assembly steps and make sure you understand them fully. If in doubt, consult a professional builder.
- Plan in advance and book enough time for the assembly. Rushing often causes errors and could cause unnecessary injuries. If you have never assembled a shed before, take your time. Depending on your level of experience and the amount of help you have you might spend a bit more time on assembly.

Cleaning

Notice

Never use corrosive detergents, wire brushes, abrasive scourers, metal or sharp utensils to clean the product.

- Use a garden hose to rinse the shed siding.
- Scrub away the remaining dirt with a cloth, using mild detergent and water.
- Sweep out the shed interiors using a broom. A leaf blower can be used as well to blow away all the debris.
- To eliminate mildew, soak a cloth in mild detergent and scrub the mold and mildew away.
- To eliminate tree sap, pour some mild detergent over the sap and let it soak thoroughly before scrubbing hard.

Maintenance

- SHED: Regularly examine for wear and tear. Stop using at first sign of damage or if components become detached.
- ROOF: Keep clean of leaves and snow with long handled, soft bristled broom. Heavy snow or ice on the roof can damage the shed making it unsafe. Do not step on the roof. Do not use the roof as additional storage area. Check the roof regularly for any damages.
- WALLS: Do not rest any objects or lean against the wall panels.
- DOORS: Keep doors closed to prevent wind damage.
- DOOR HINGES: This is the weakest point of the shed so you should take extra care. The hinges can seize up after a while, so you should keep them well lubricated.
- MOISTURE: With changing temperatures, condensation will accumulate inside the shed. Good ventilation will help in regulating and avoiding moisture. Open the door frequently to allow for proper ventilation.
- FASTENERS: Regularly check that all the components and fasteners are tightened.

Disposal



Dispose of the product according to local regulations. If in doubt, consult your local authorities.

Specifications

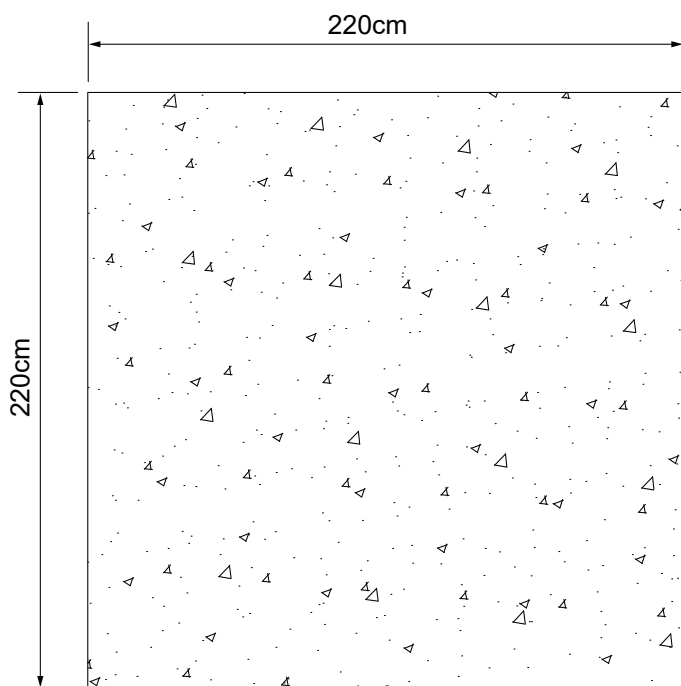
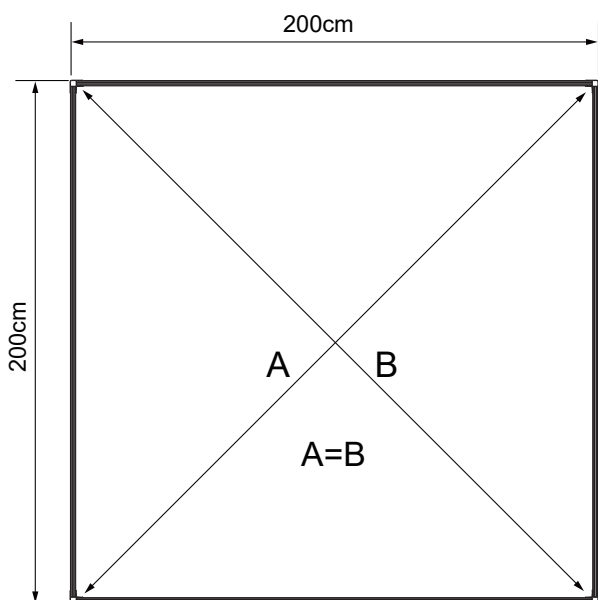
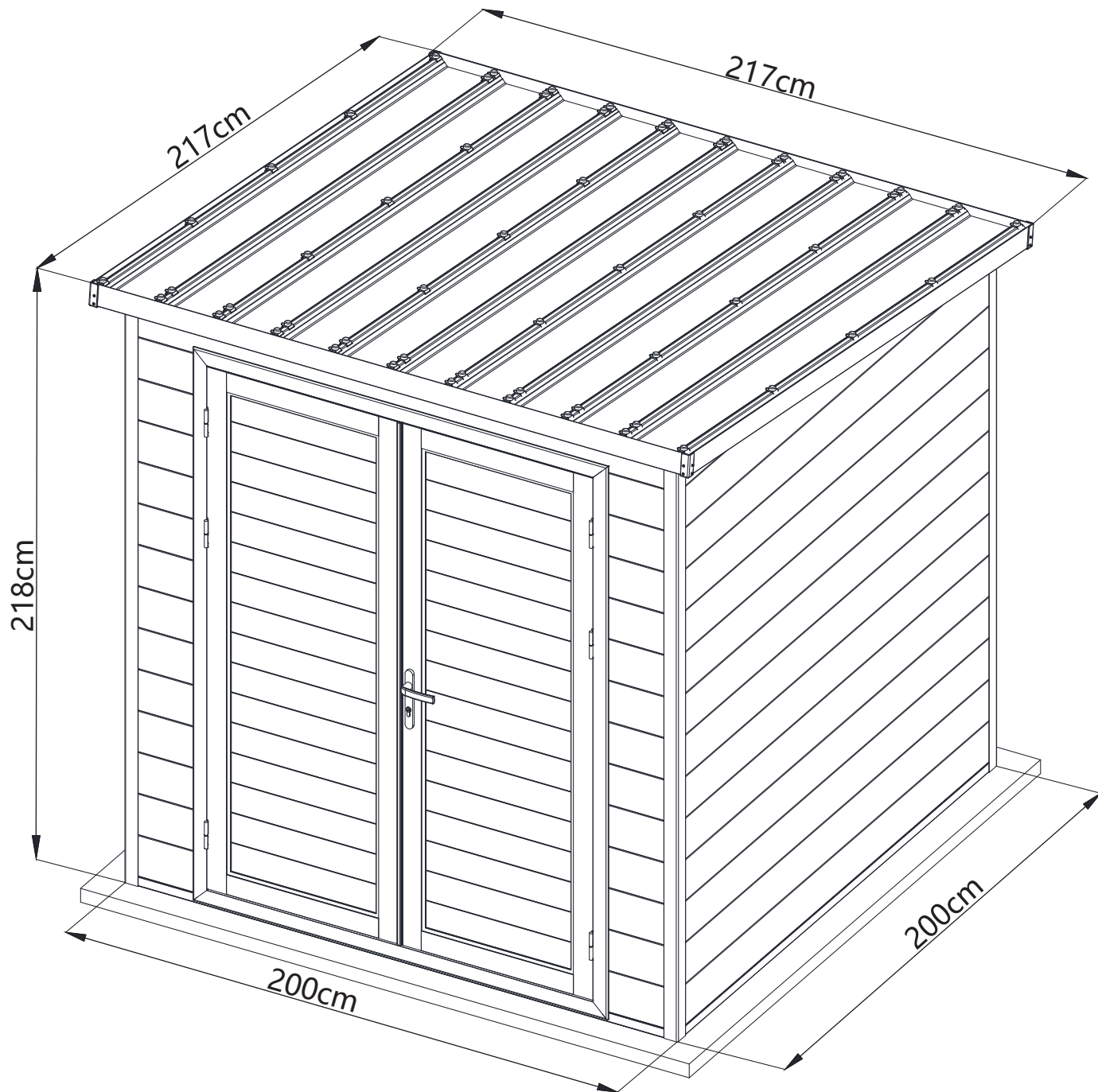

Net weight	290 kg
Dimensions (D x W x H)	approx. 2 x 2 x 2.18m
Storage area	approx. 4m ²

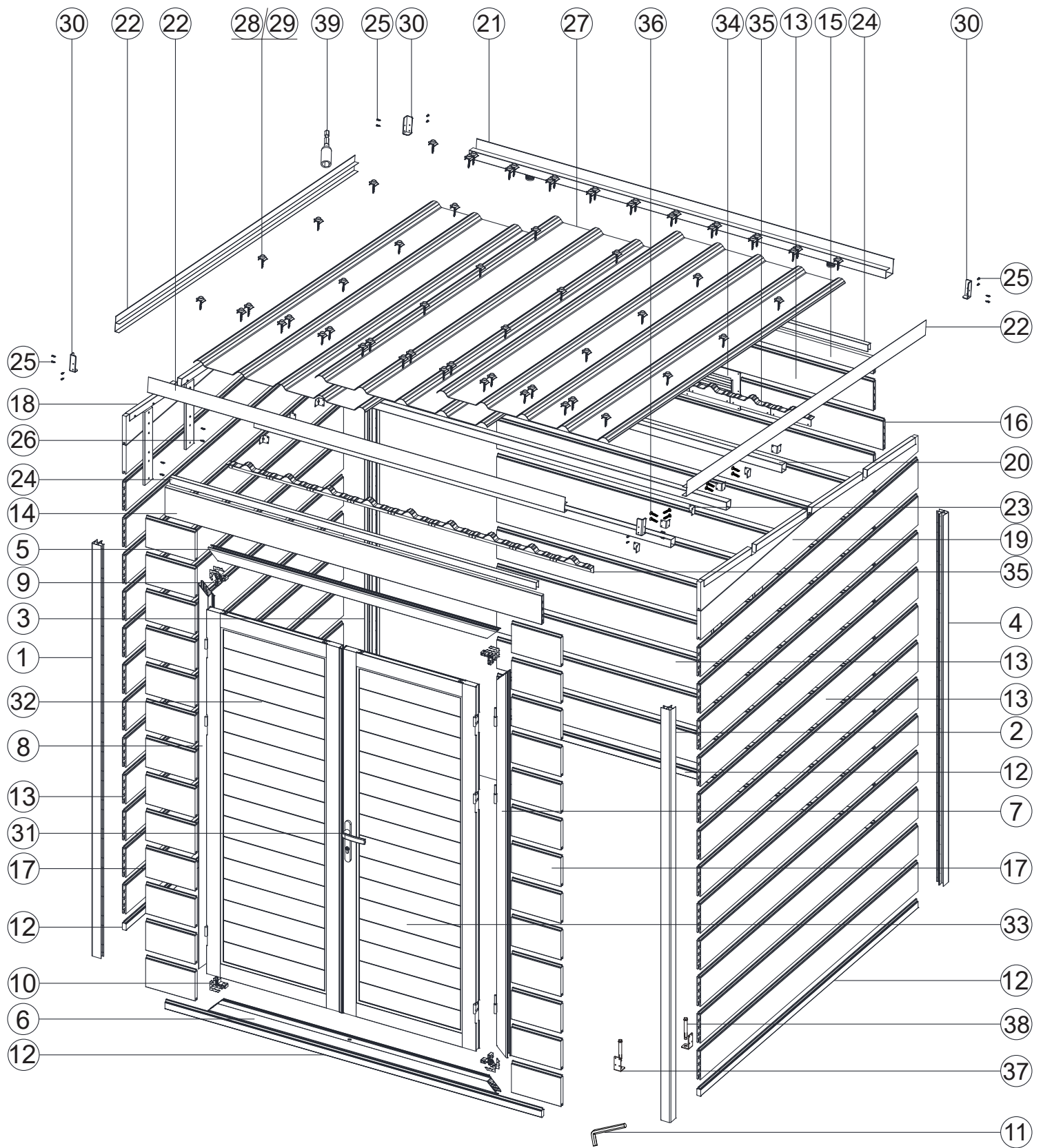





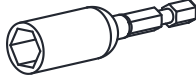

No.	IMAGE	mm	QTY
①			X1
②			X1
③			X1
④			X1
⑤		1500	X1
⑥		1500	X1
⑦		2000	X1
⑧		2000	X1
⑨			X4
⑩			X8
⑪			X1
⑫		1952	X4
⑬		1952	X35
⑭		1952	X1
⑮		1952	X1
⑯		738	X2
⑰		256	X26
⑱			X1

No.	IMAGE	mm	QTY
⑲			X1
⑳		2165	X3
㉑		2165	X1
㉒		2165	X3
㉓			X12
㉔		1898	X2
㉕		ST4×15	X325
㉖		ST4×20	X25
㉗			X3
㉘		ST5×60	X65
㉙			X65
㉚			X4
㉛			X1
㉜			X1
㉝			X1
㉞			X1
㉟			X18
㊱		ST4×15	X65

No.	IMAGE	mm	QTY	No.	IMAGE	mm	QTY
37			X8	39		8mm	X1
38		M8×100	X8				

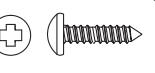
- | | | | | | | |
|----------|---|---|---|--|---|---|
| 1 | 
① X1 | 
② X1 | 
③ X1 | 
④ X1 | 
⑫ X4 | 
⑳ X8 |
|----------|---|---|---|--|---|---|

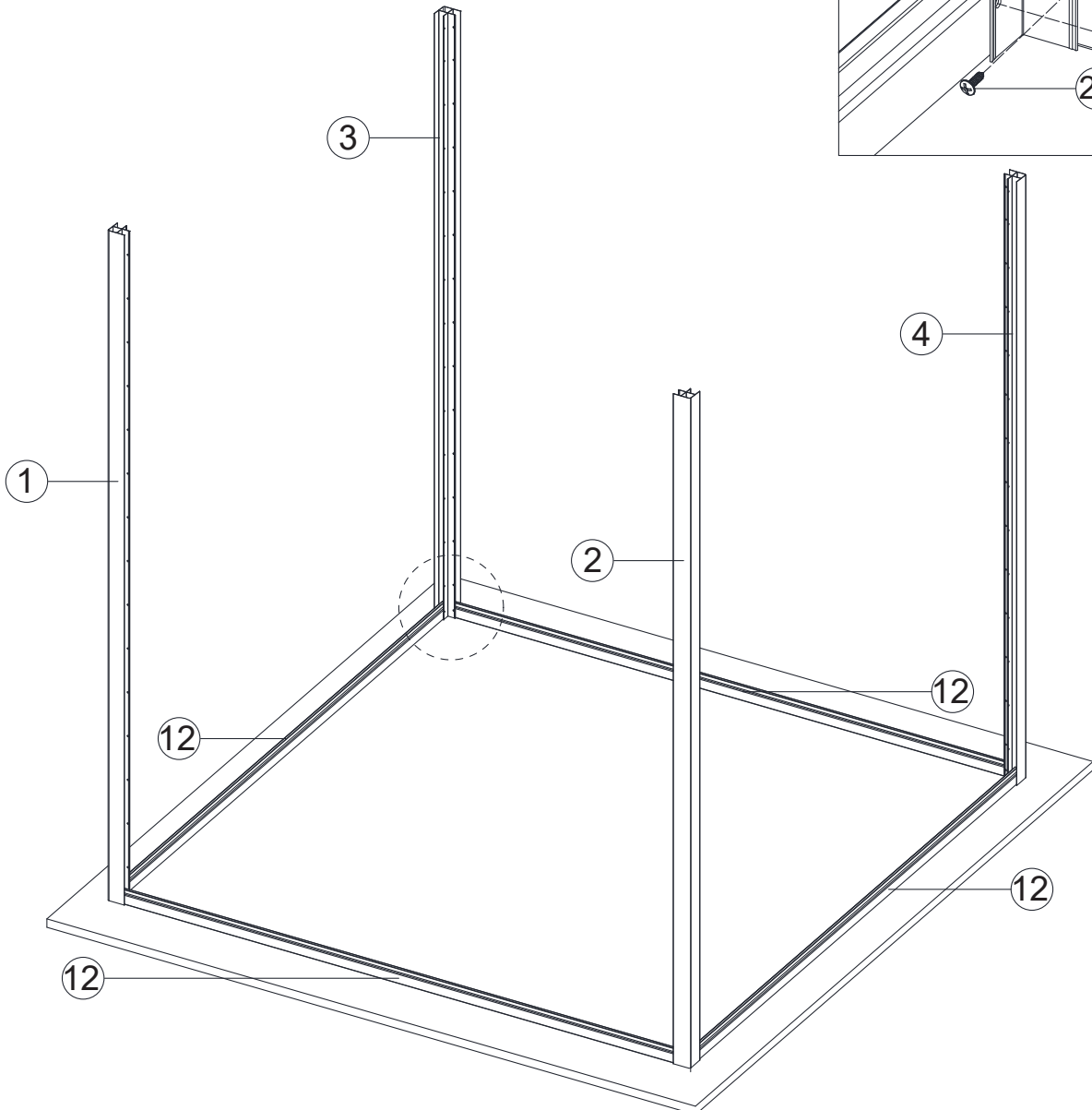
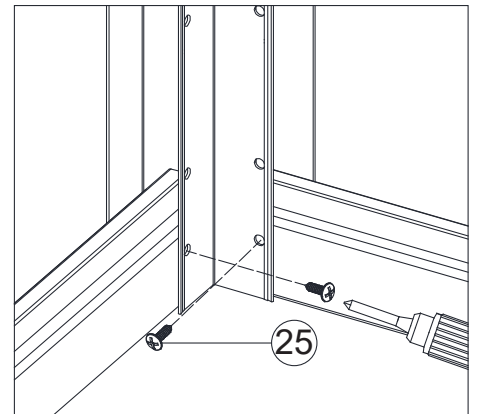
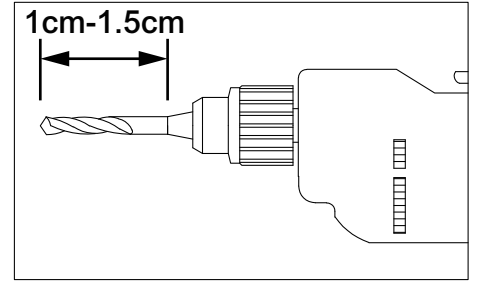
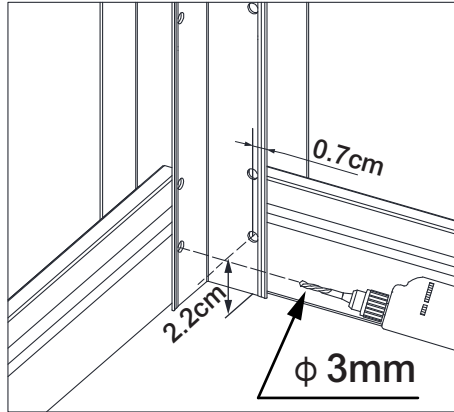
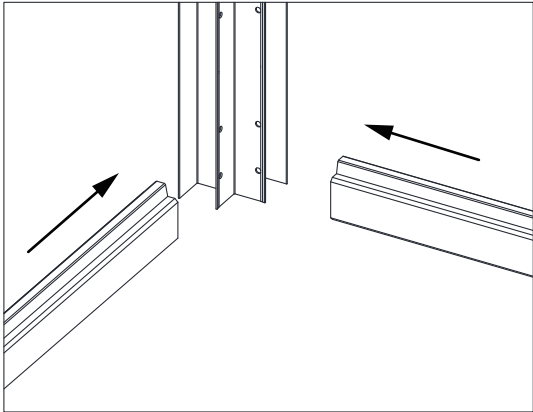

2



13 X3



17 X2

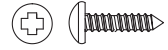

25 X16

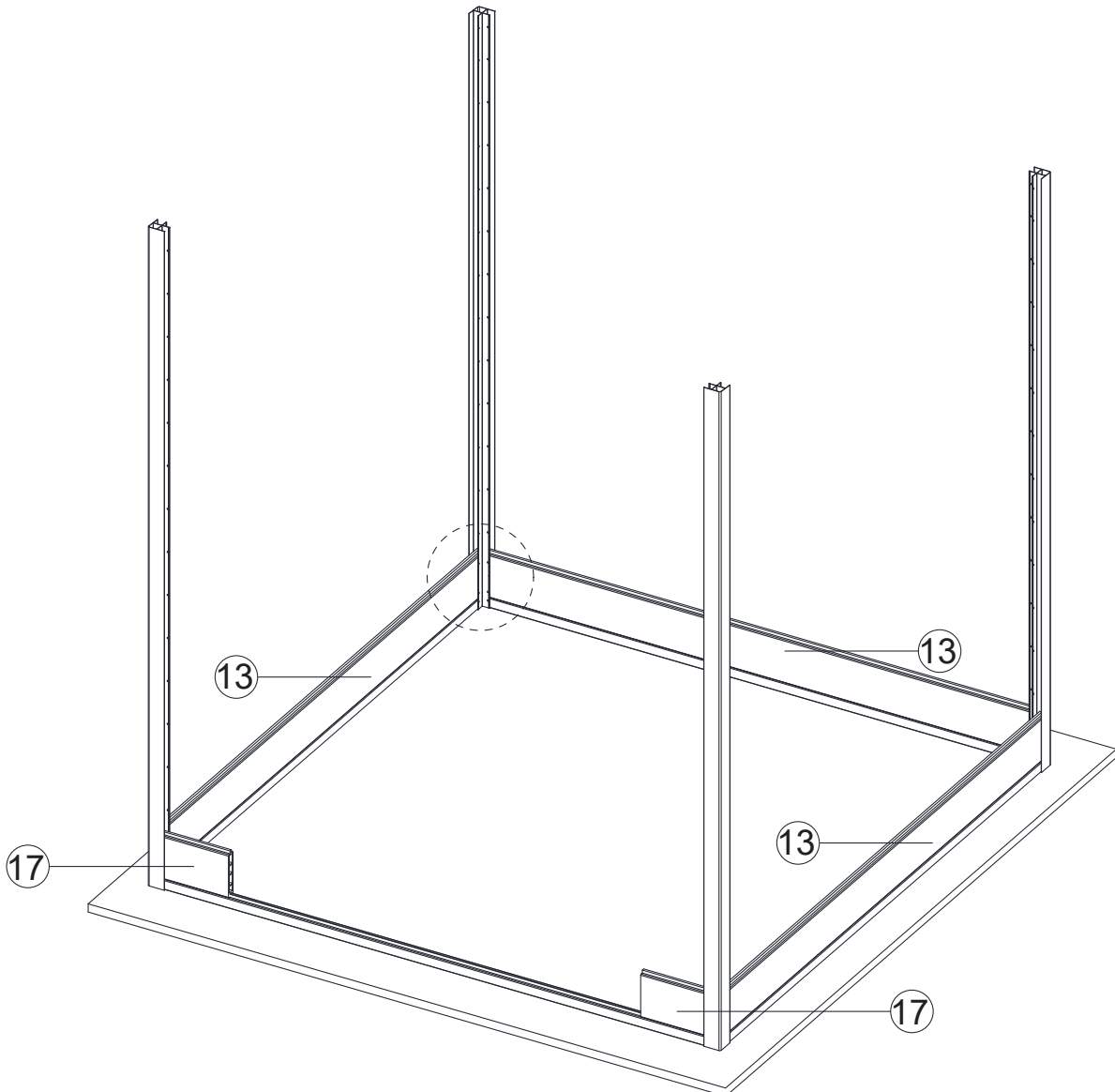
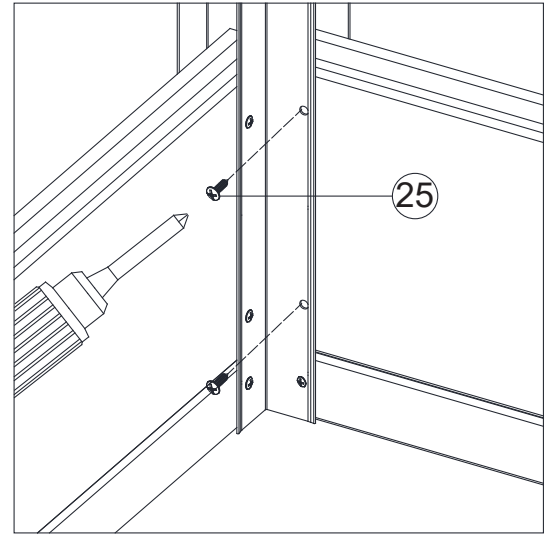
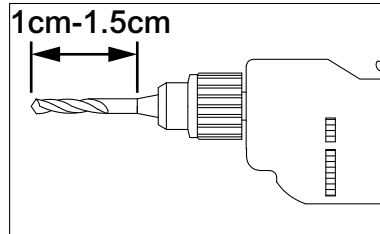
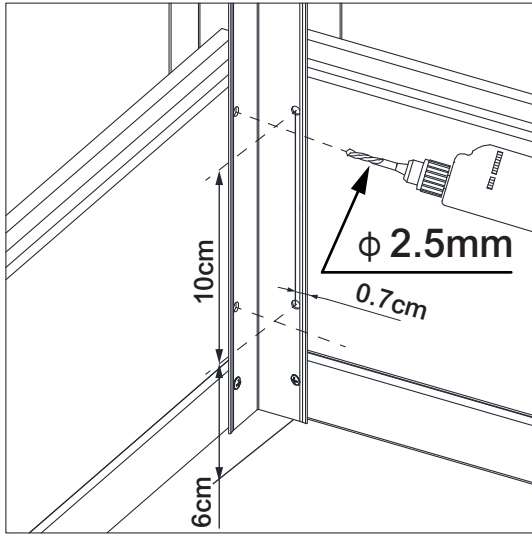

3

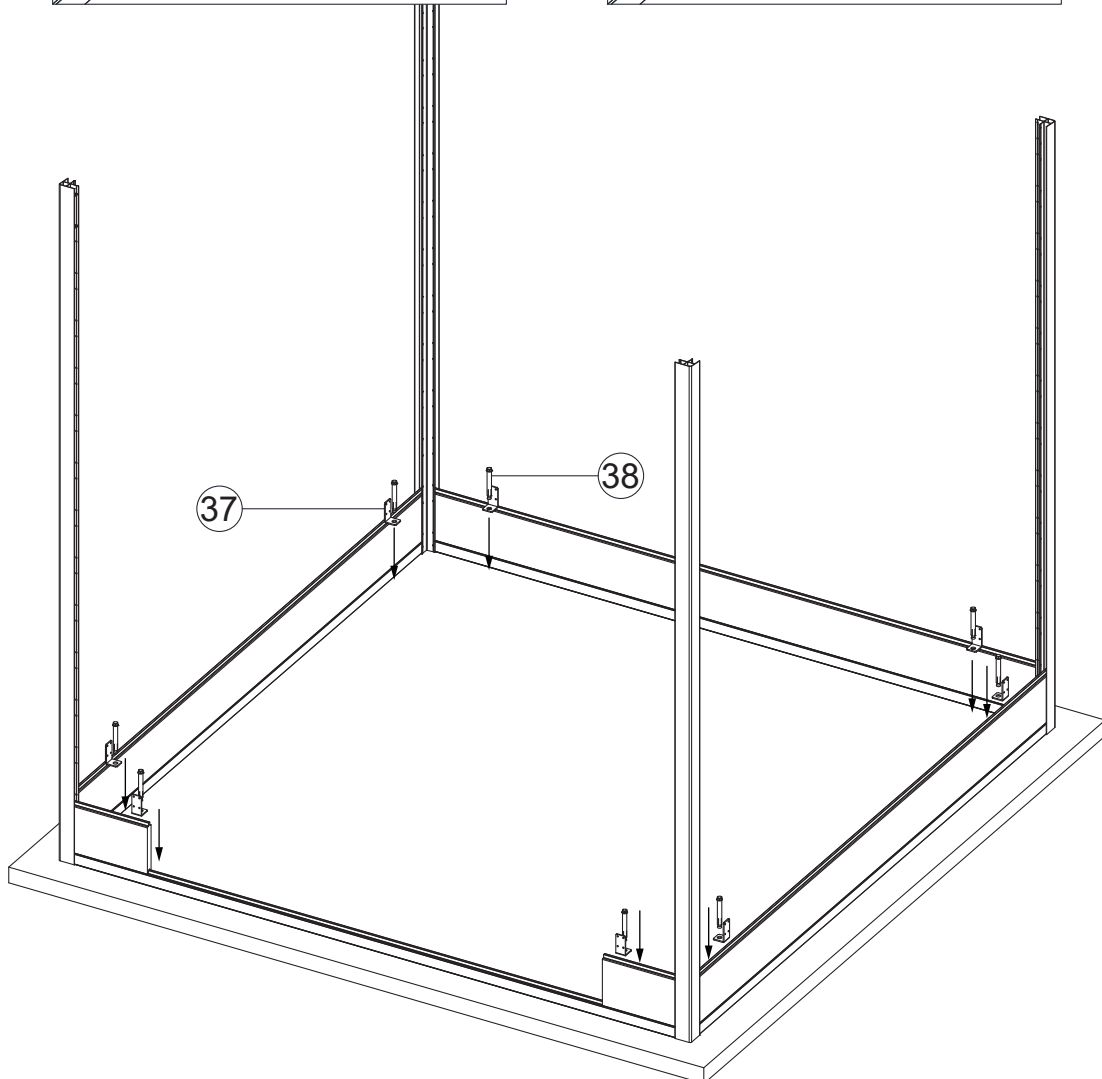
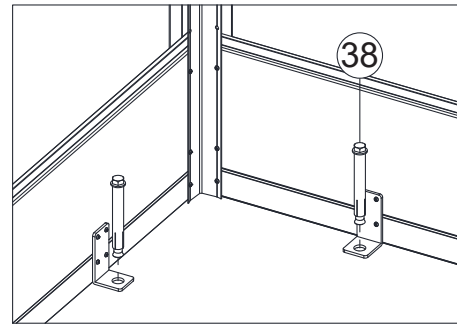
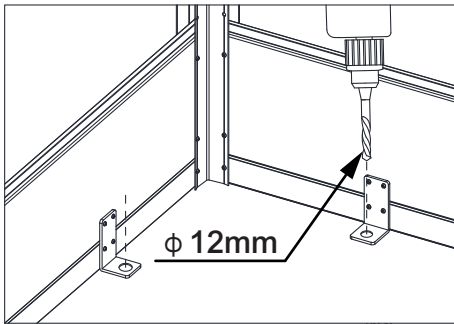
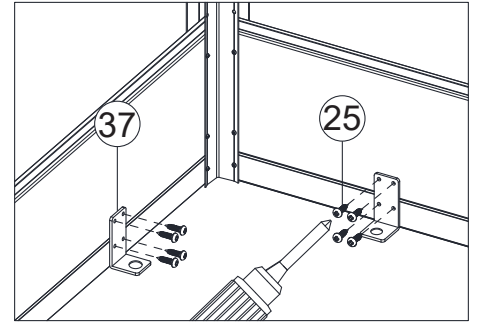
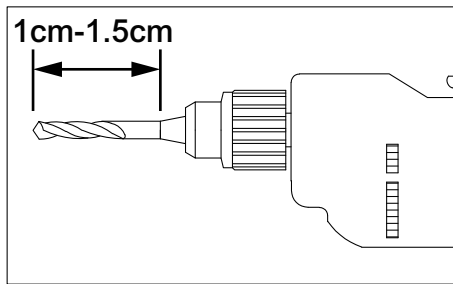
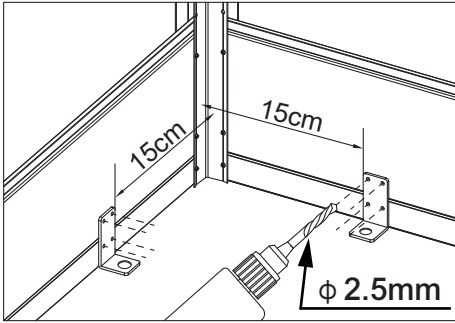
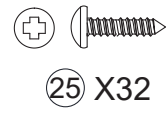
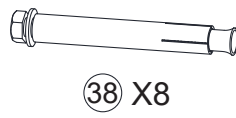
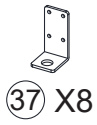

4



13 X12





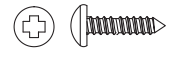

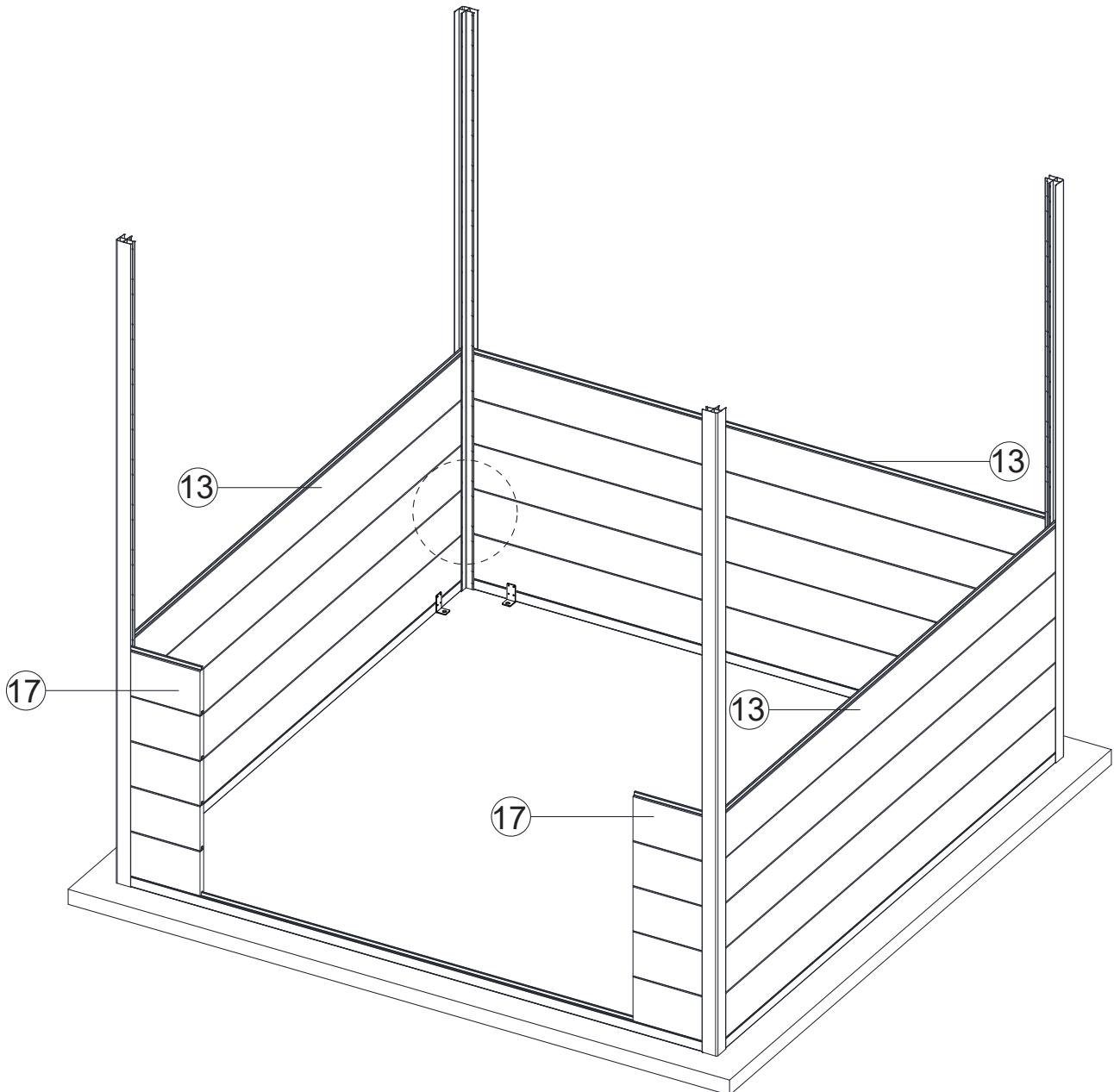
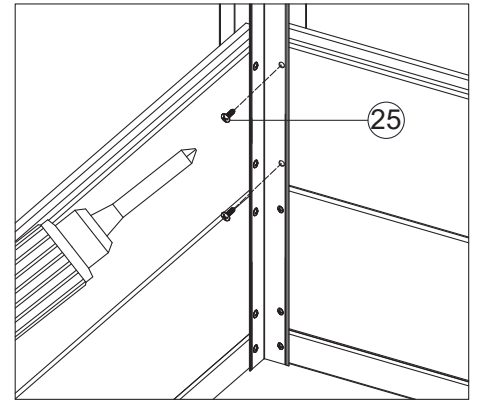
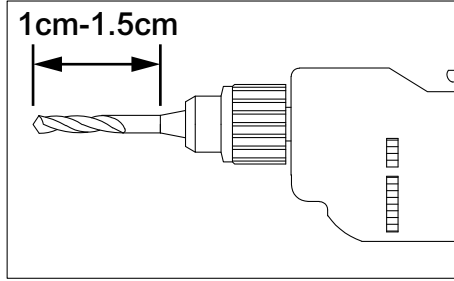
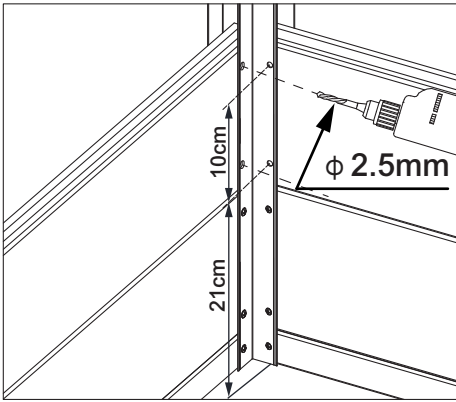

17 X8



25 X64



- | | | | | | | | |
|---|---|---|---|---|---|--|--|
| 5 | 
5 X1 | 
6 X1 | 
7 X1 | 
8 X1 | 
9 X4 | 
10 X8 | 
11 X1 |
|---|---|---|---|---|---|--|--|

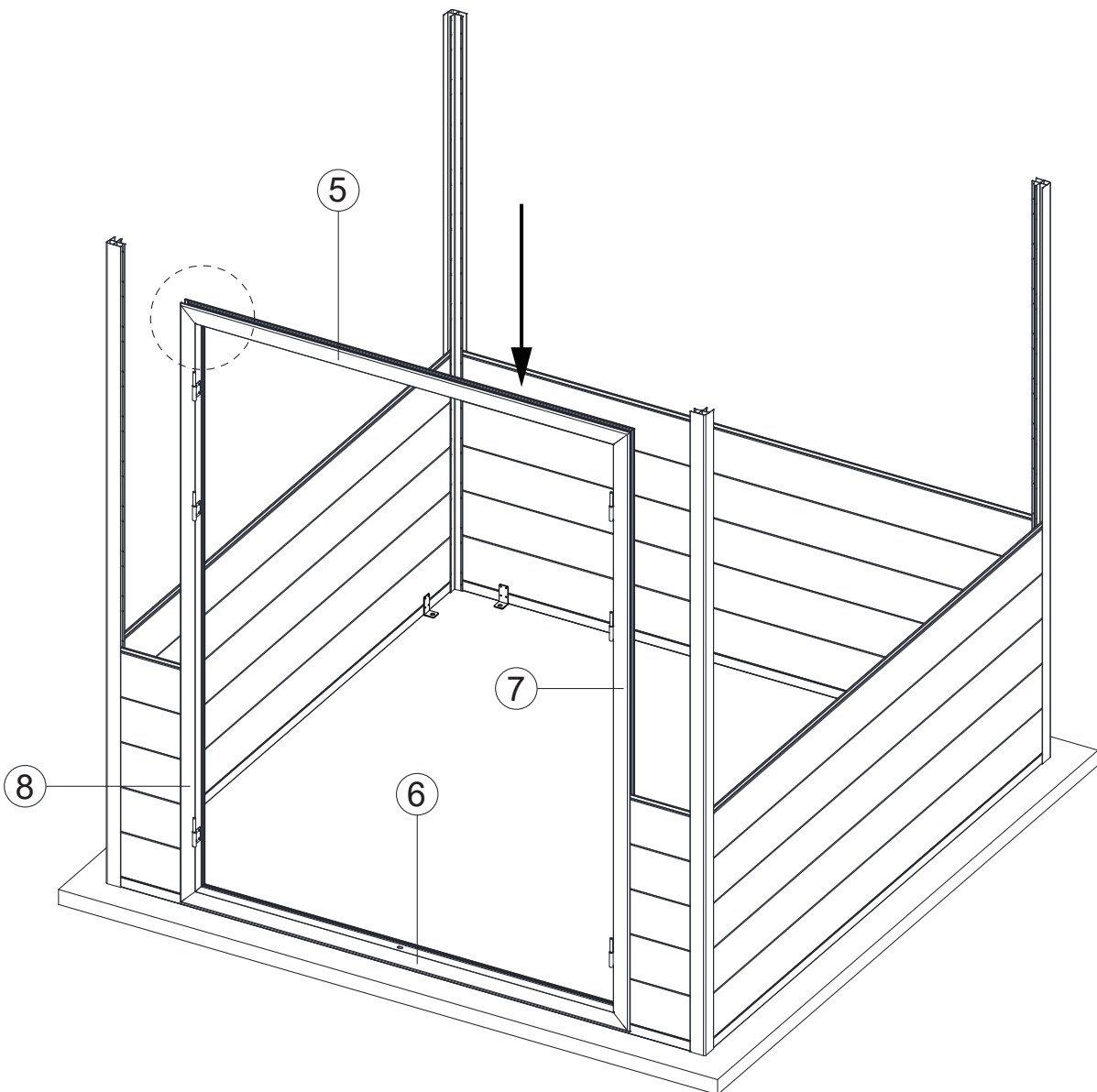
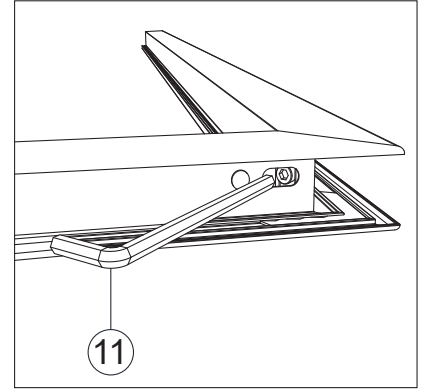
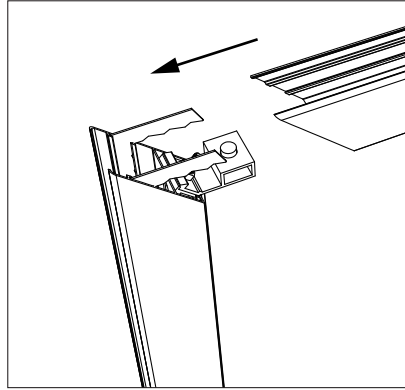
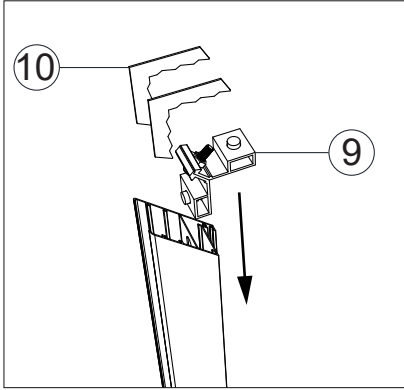

6

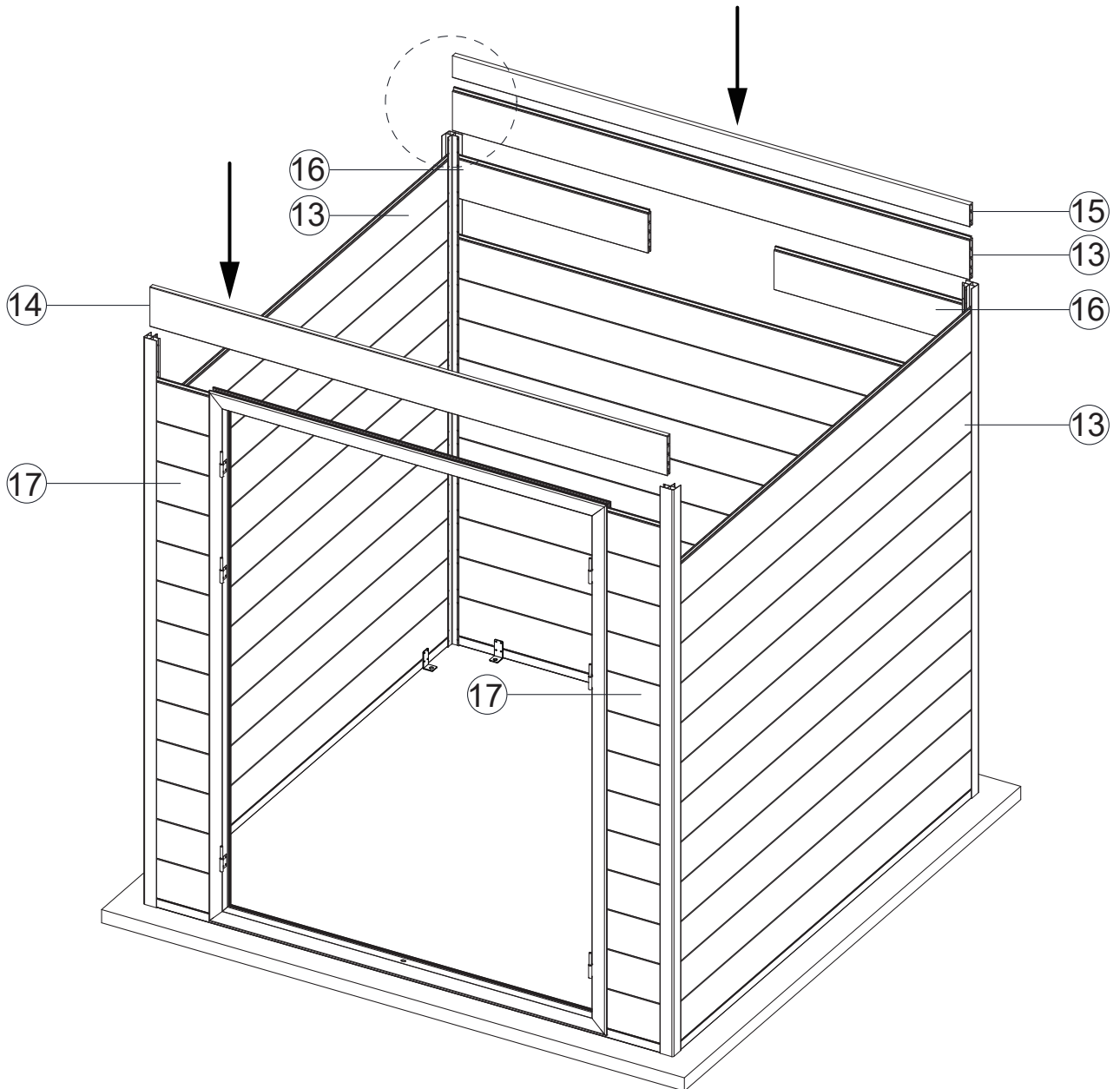
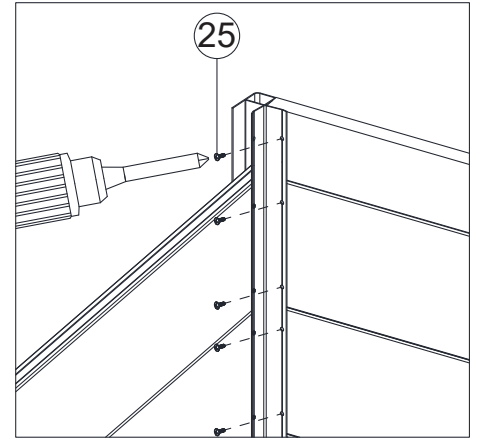
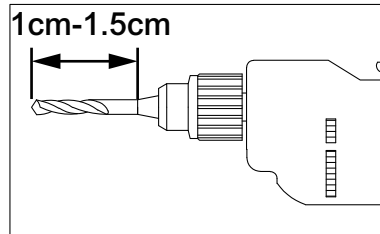
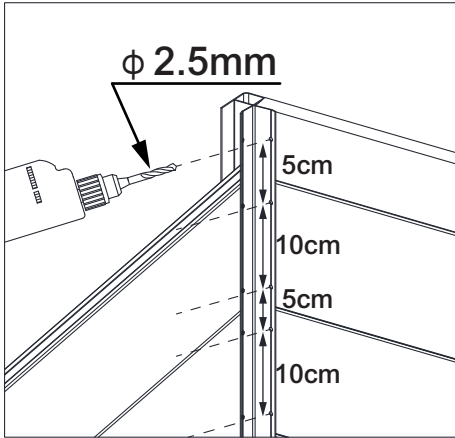
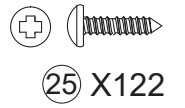
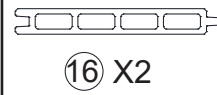
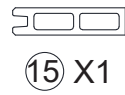
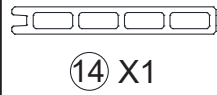

7

24 X2

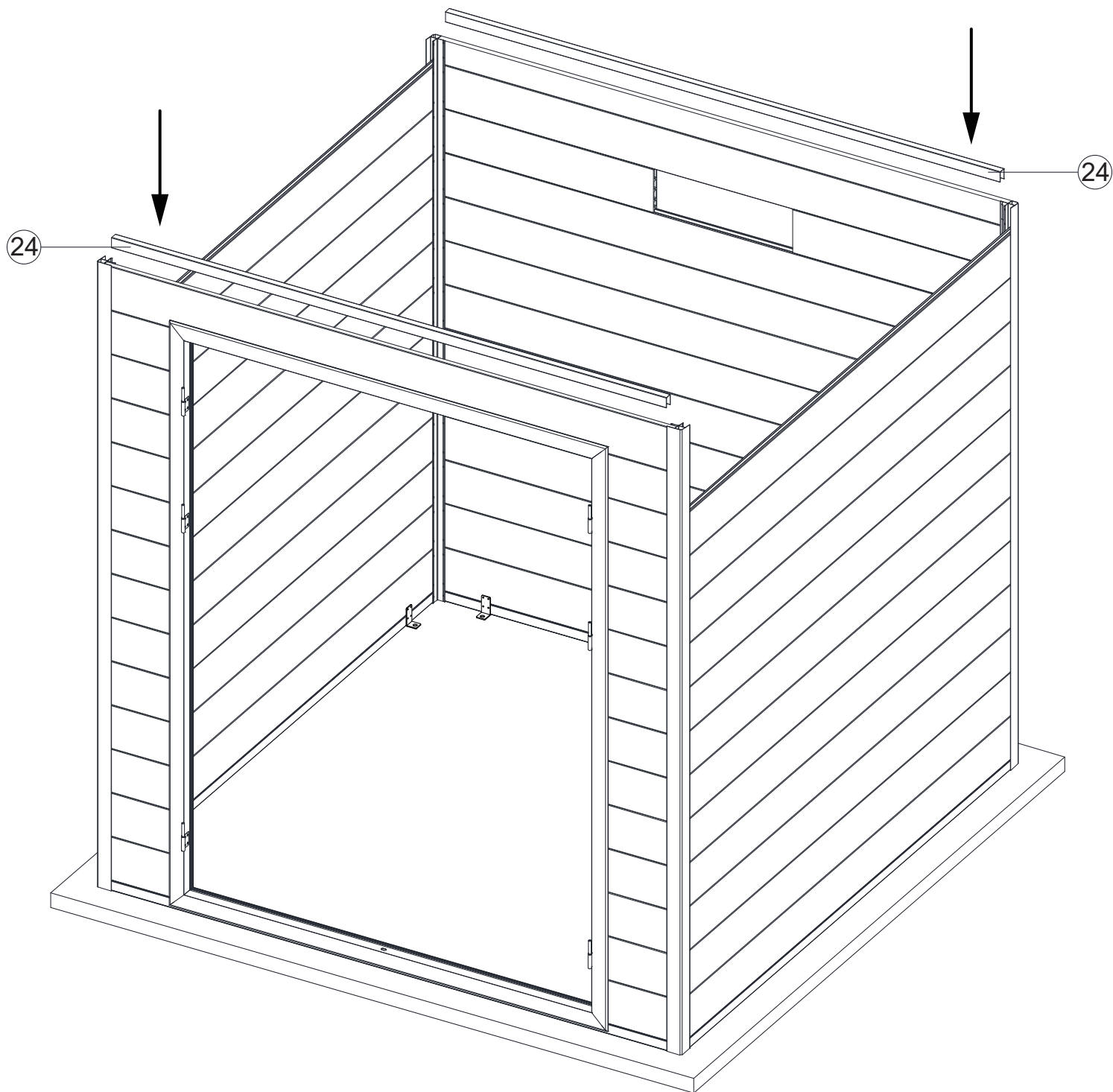

8



18 X1



19 X1

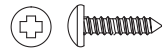

25 X10

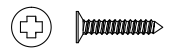

26 X8

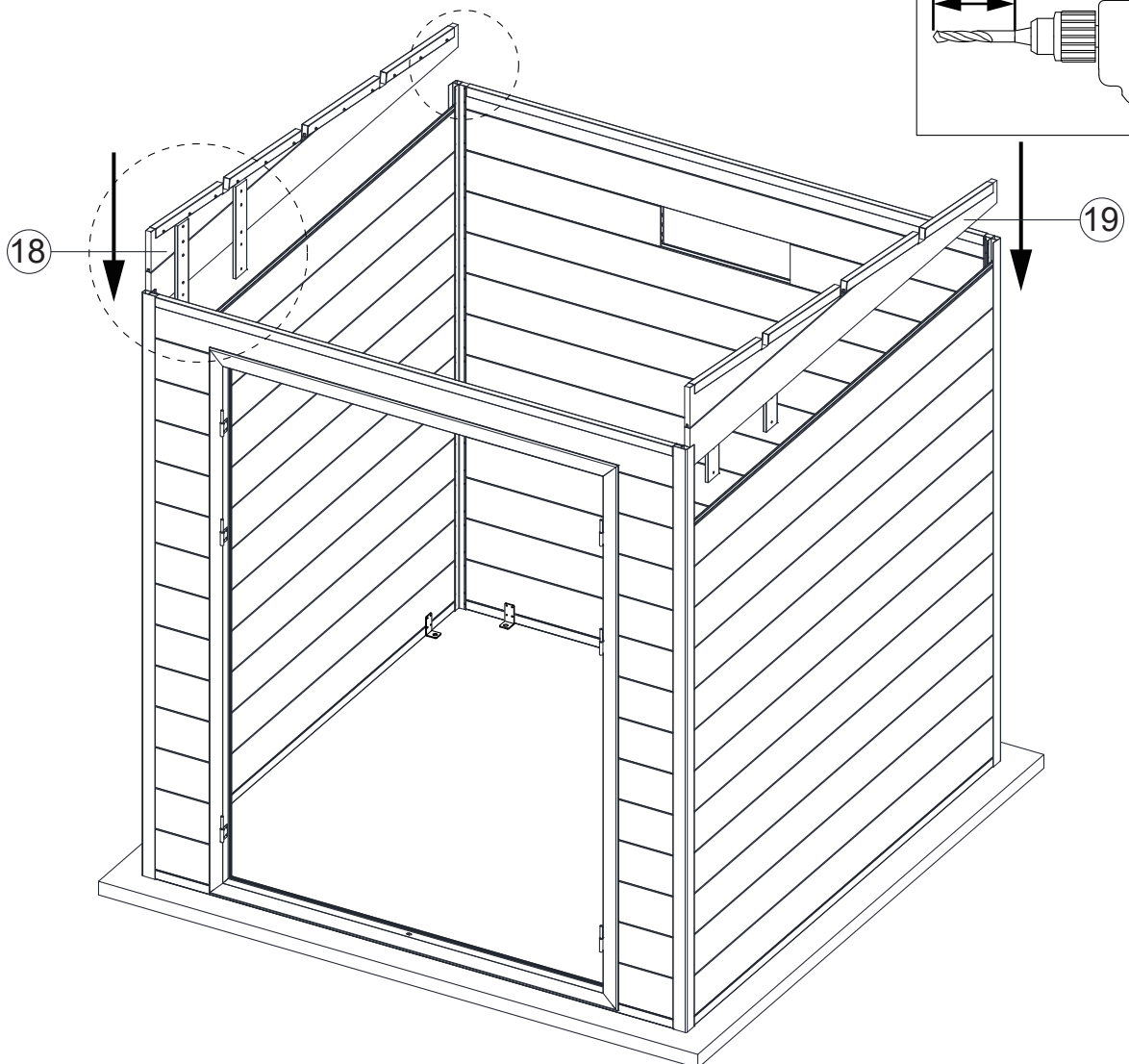
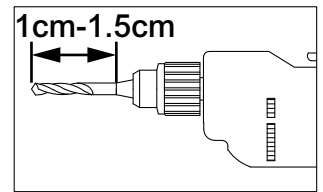
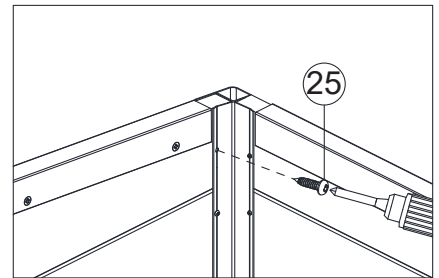
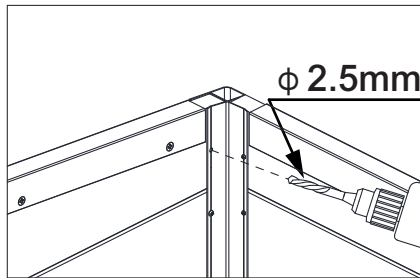
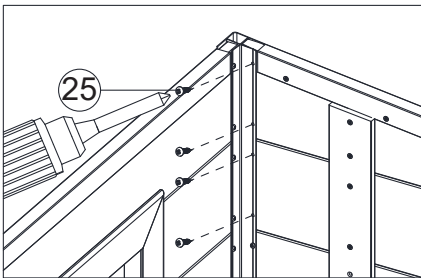
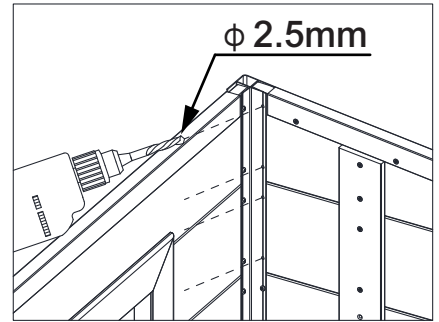
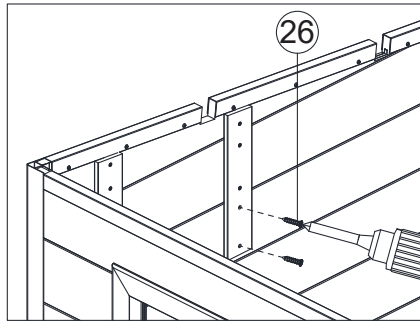
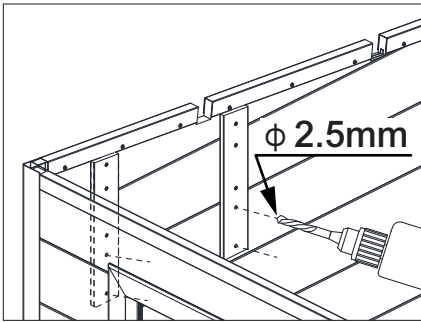

9

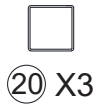

20 X3



23 X12

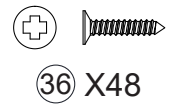

36 X48

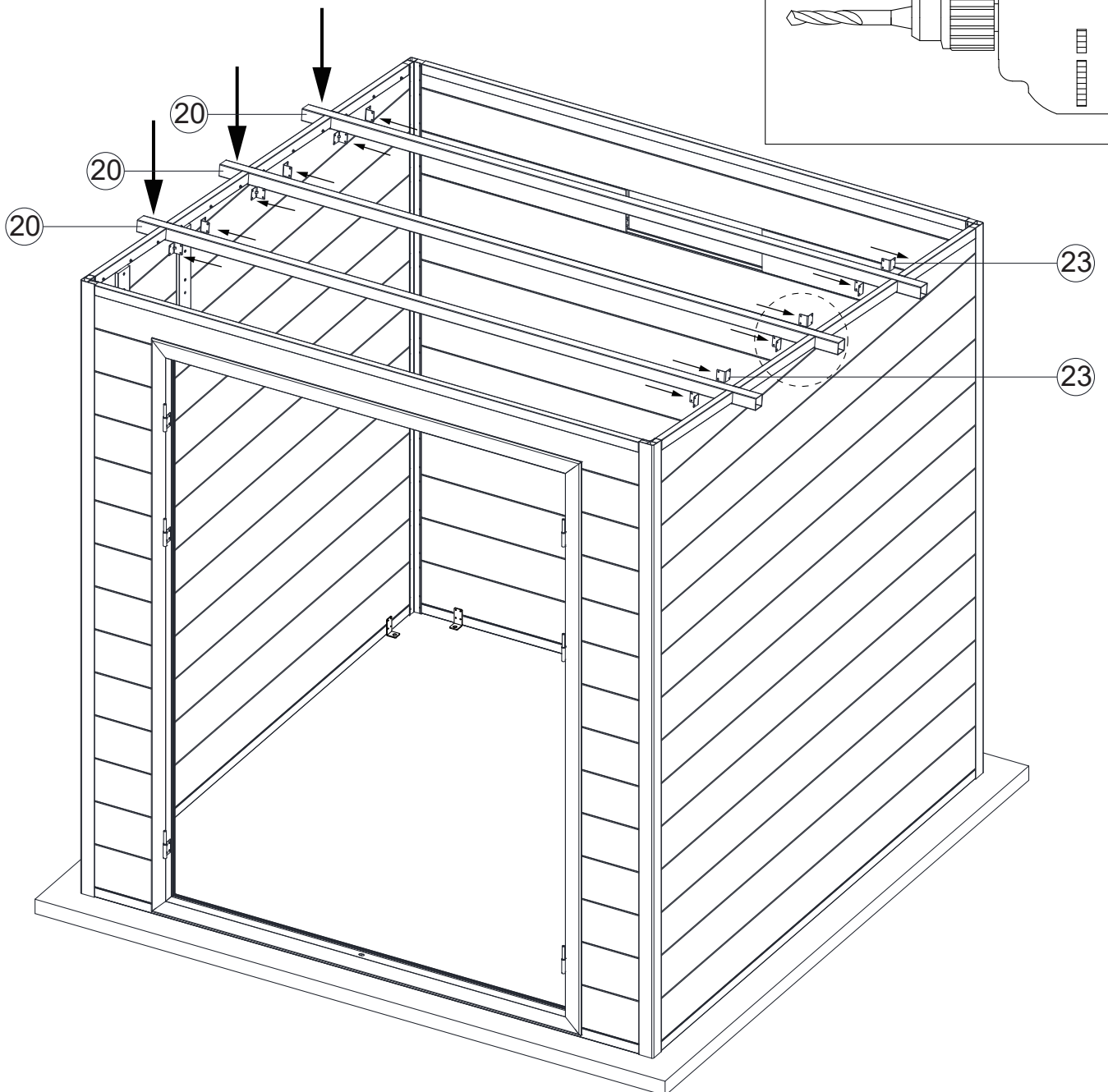
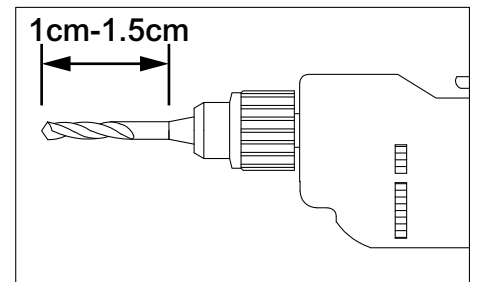
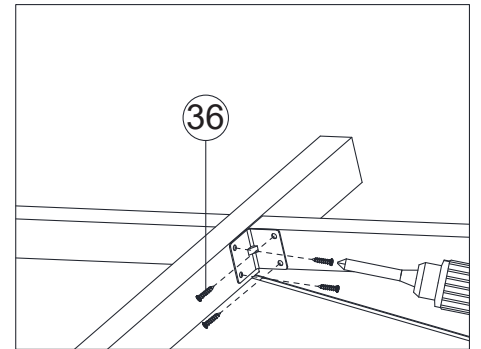
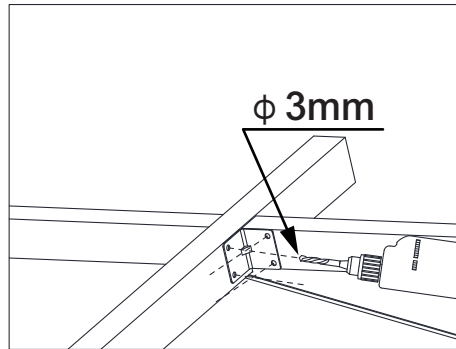
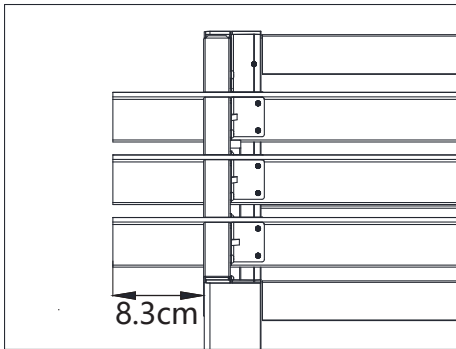

10

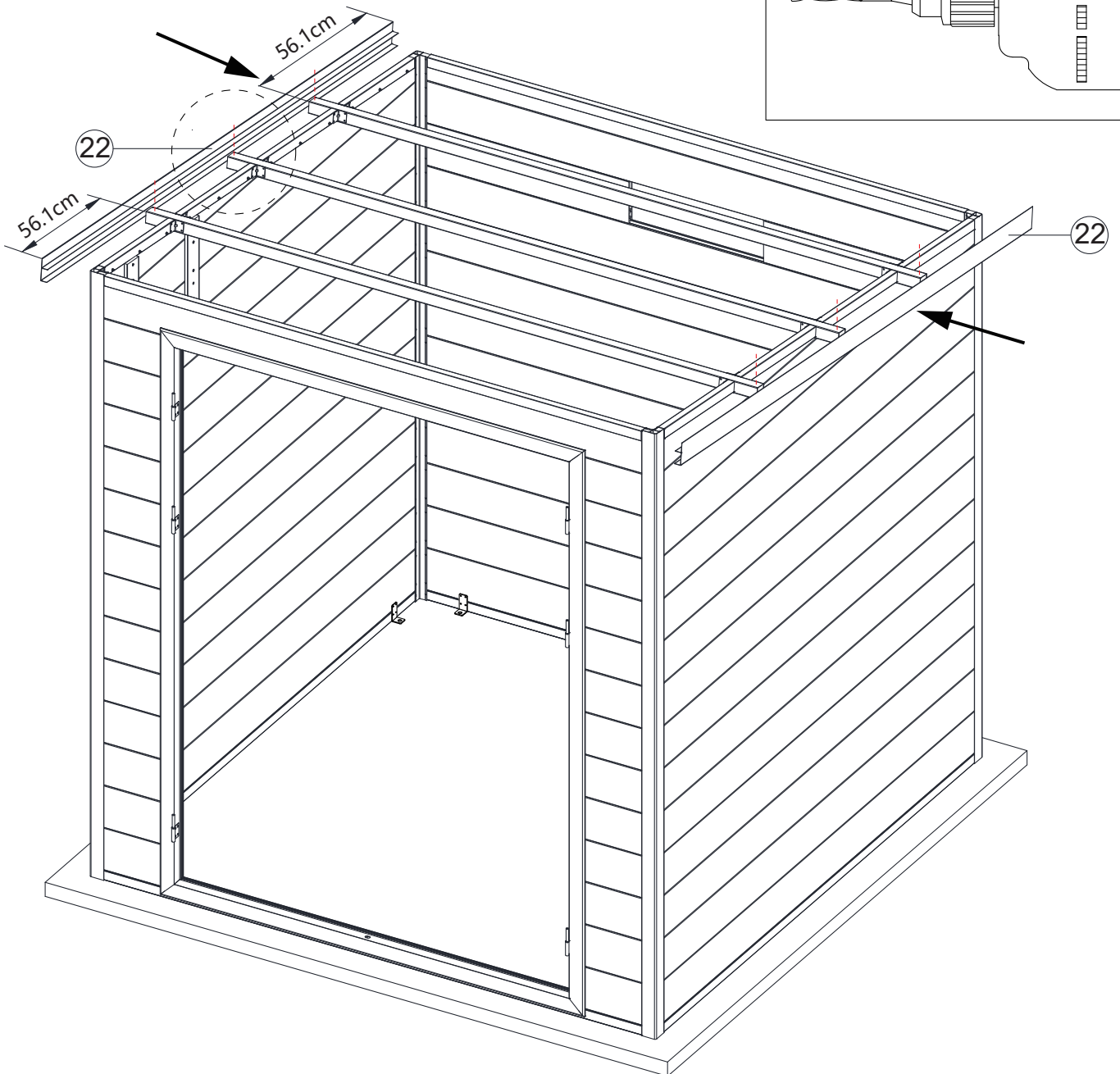
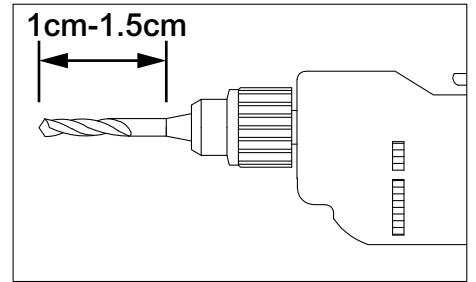
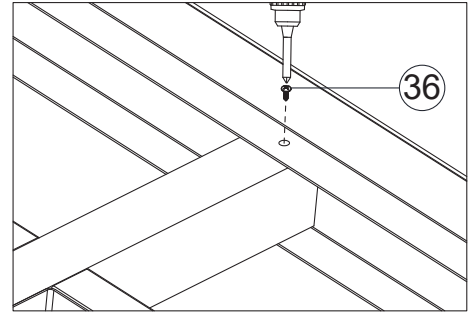
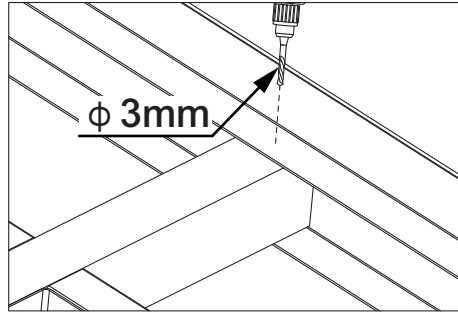
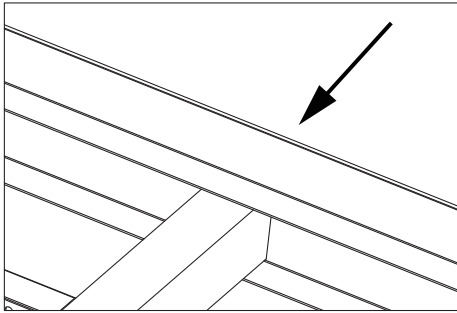
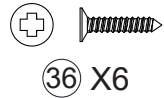
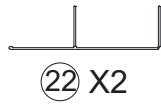

11

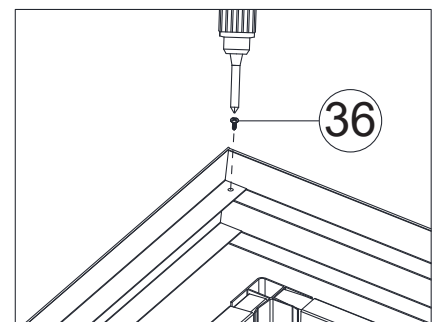
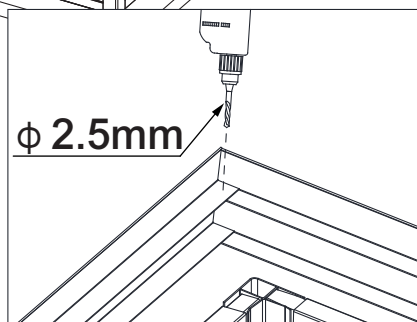
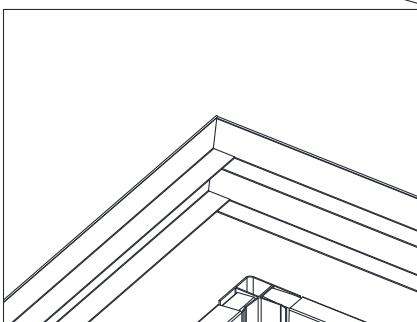
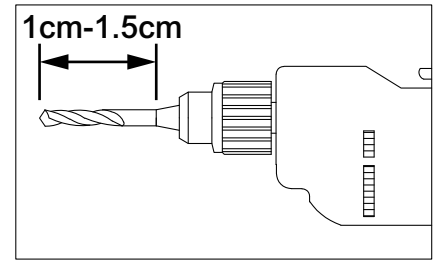
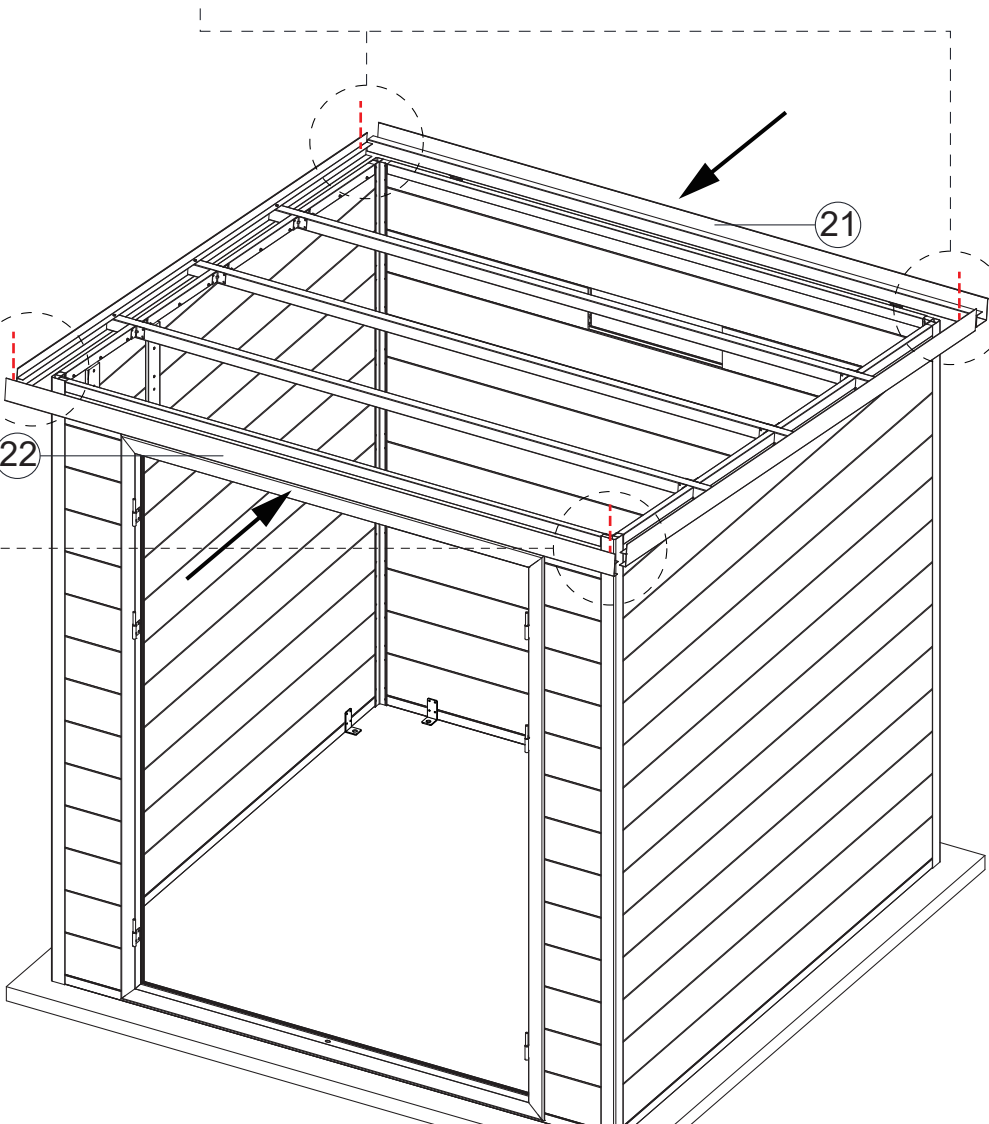
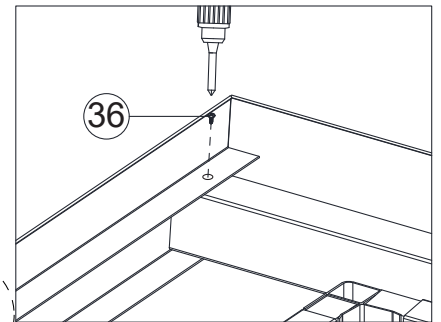
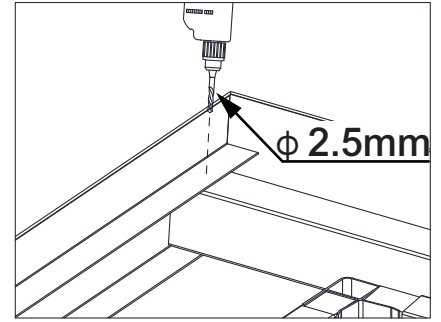
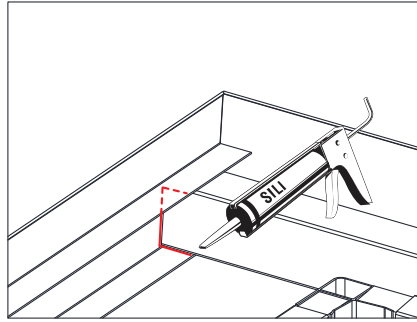
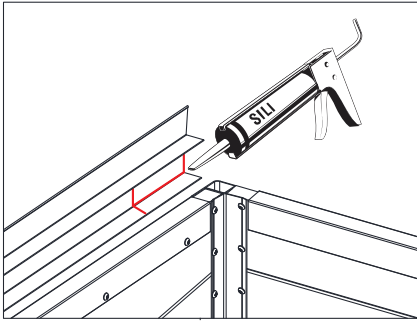
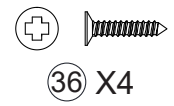
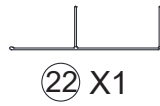

12

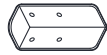

30 X4



25 X16

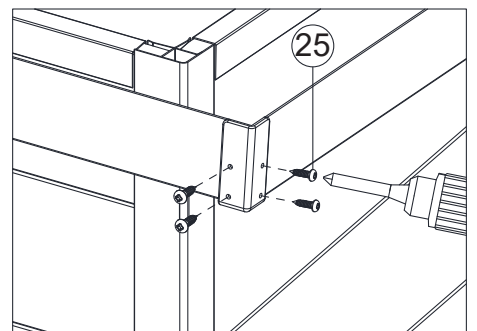
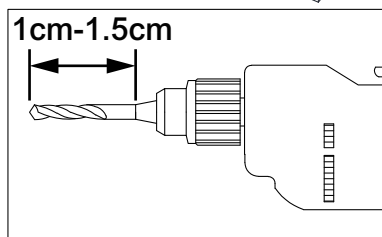
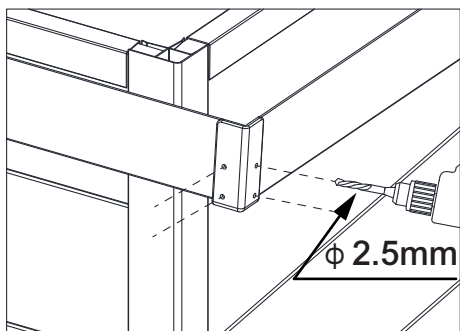
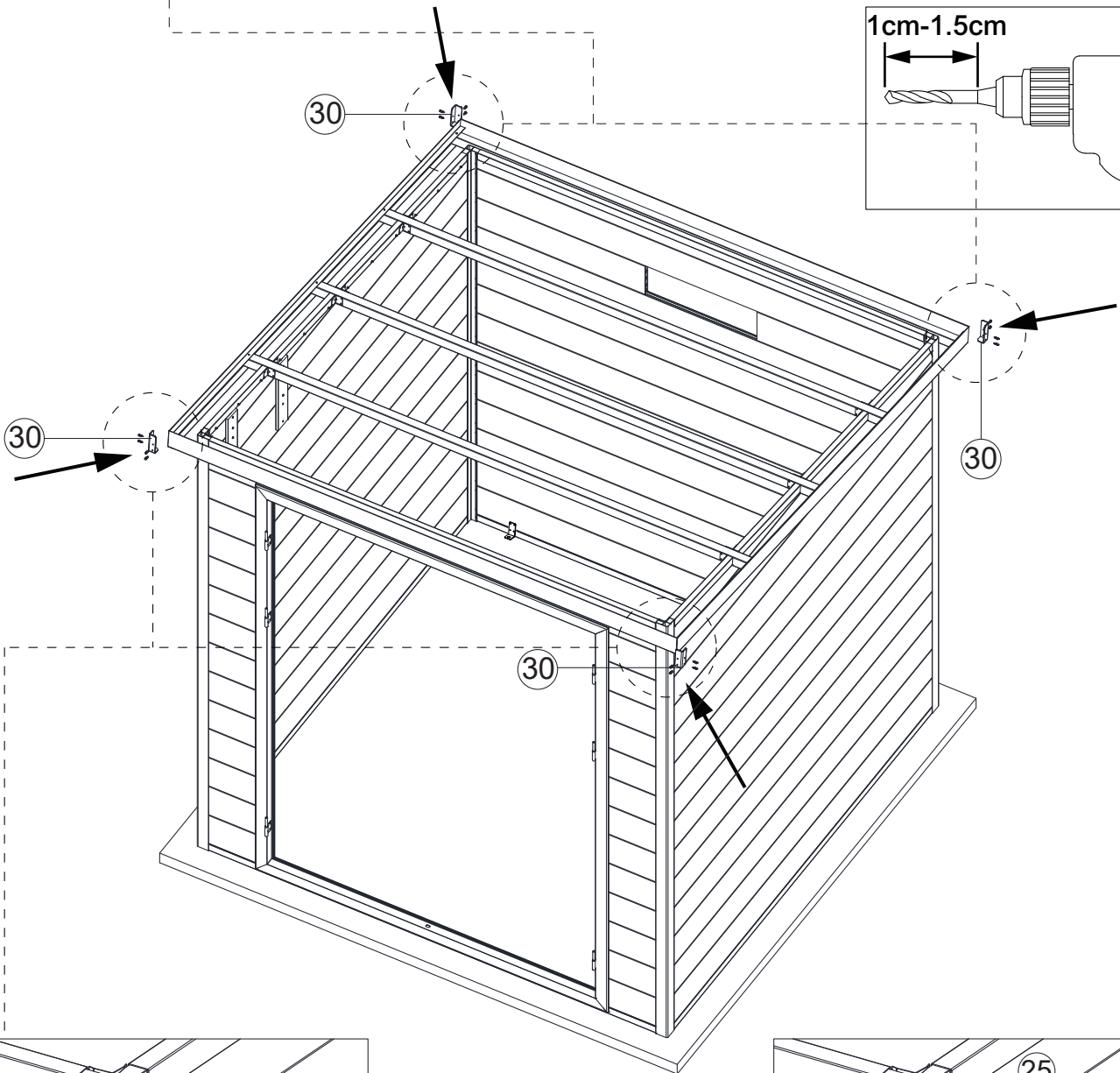
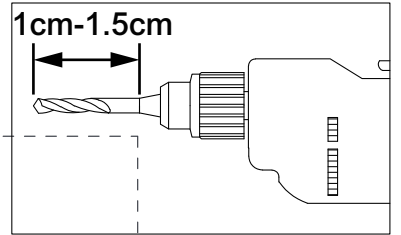
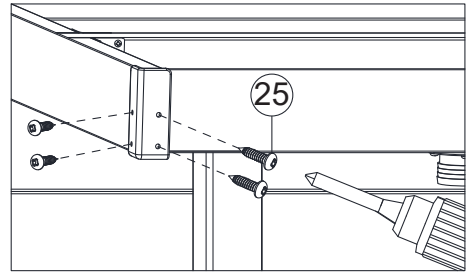
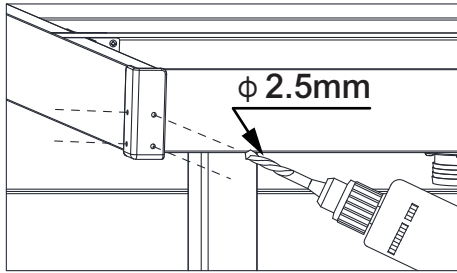
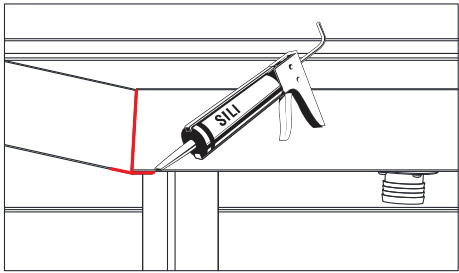

13

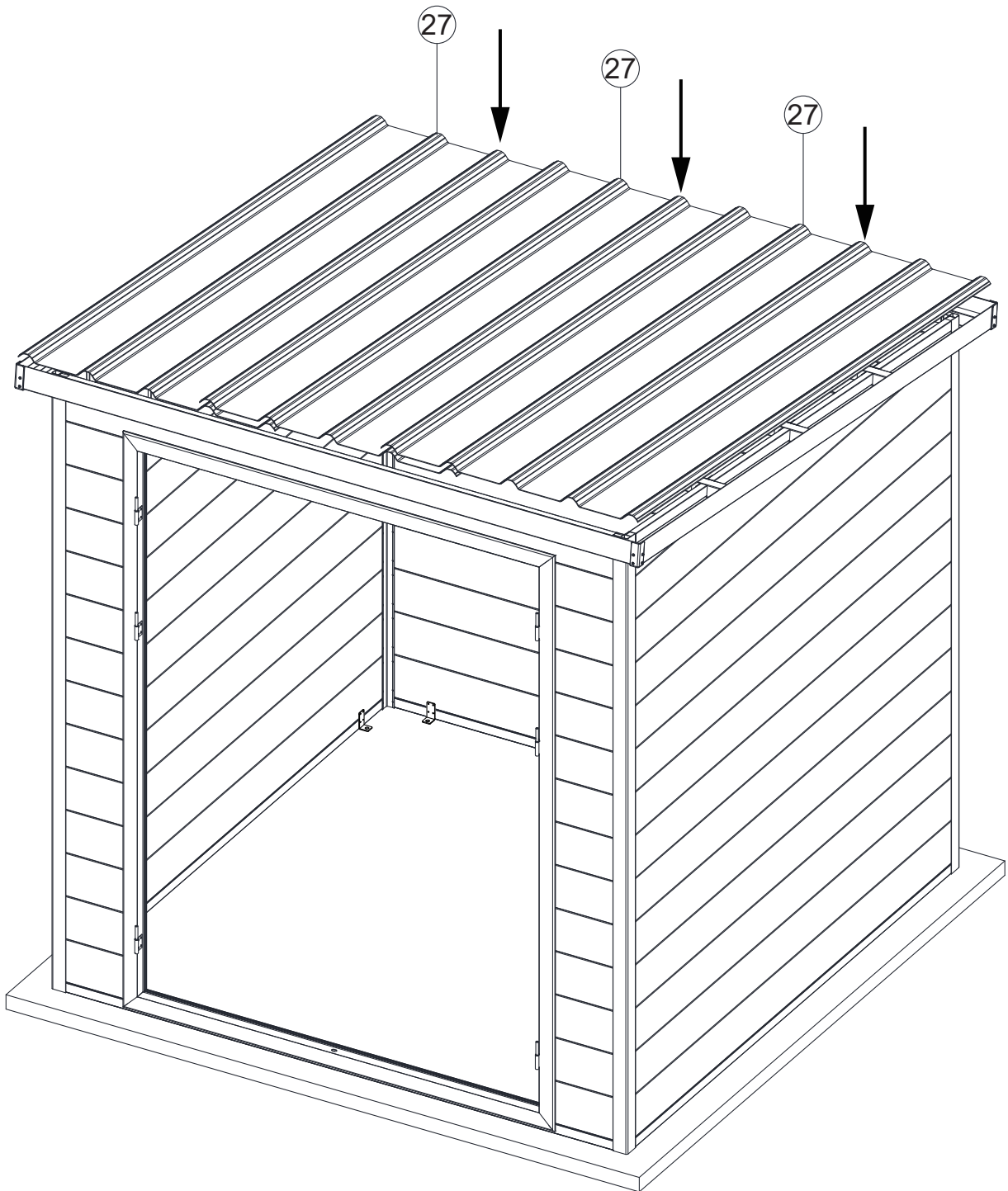
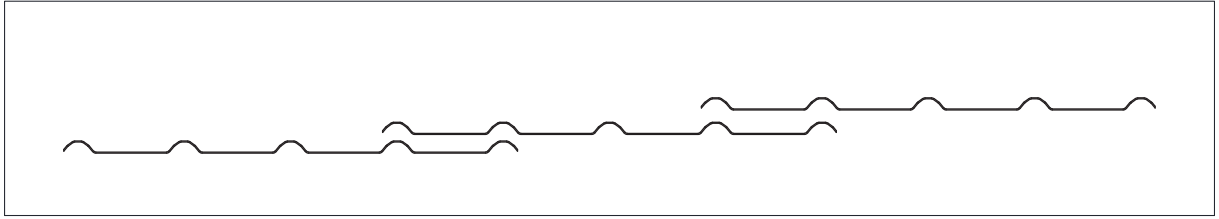

14

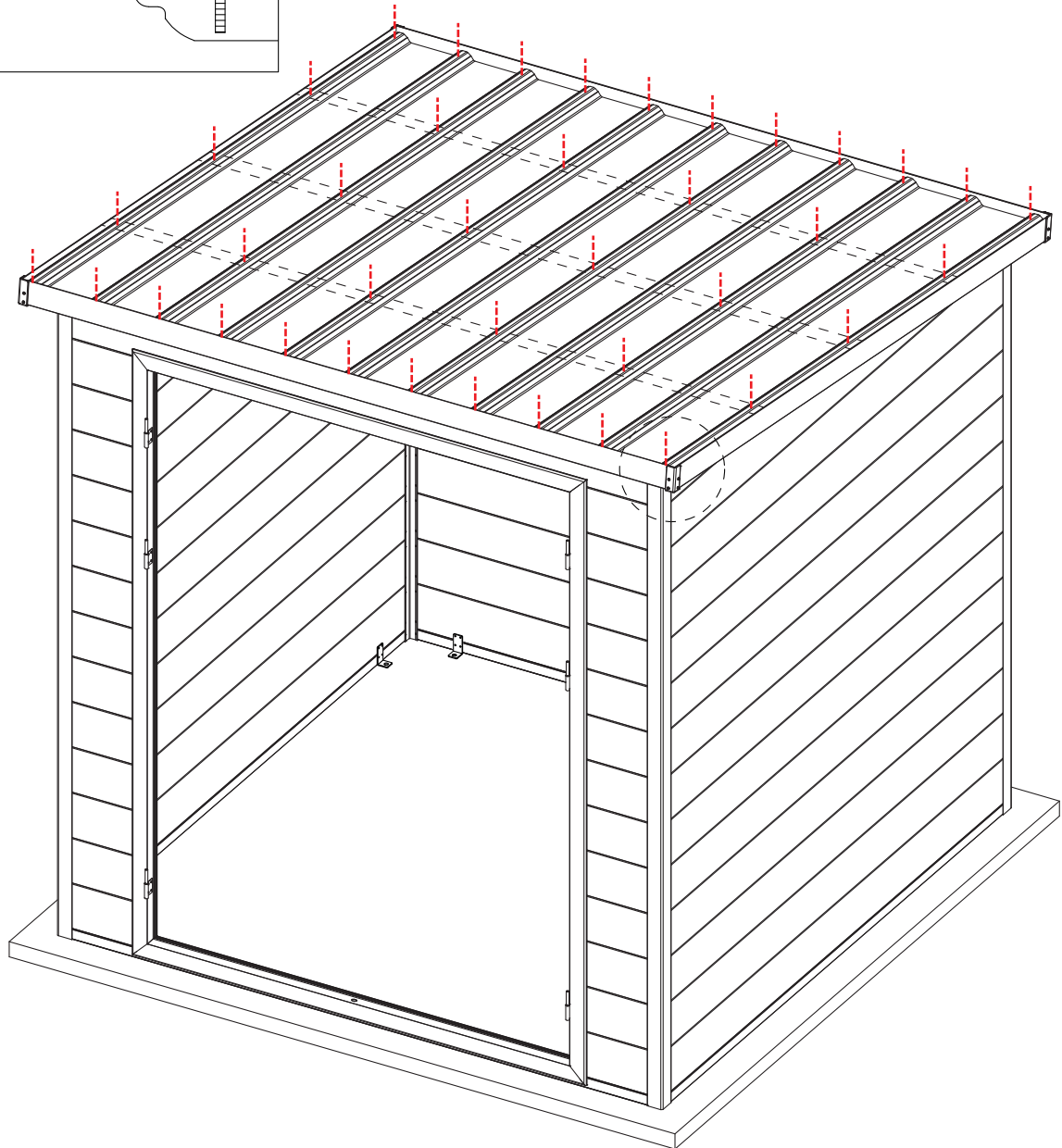
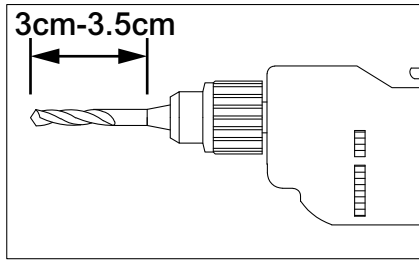
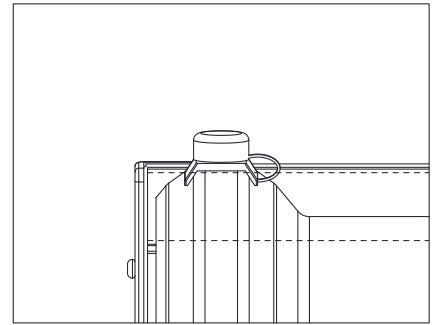
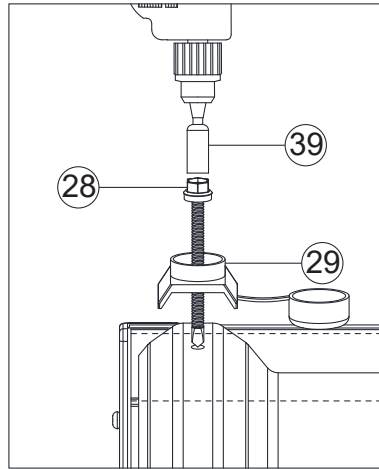
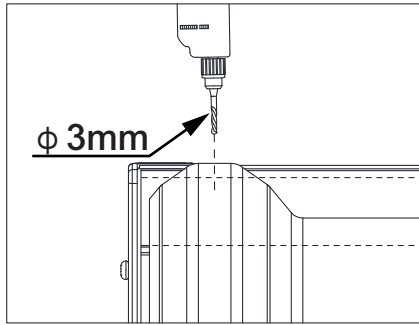
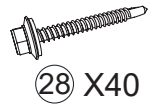

15

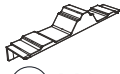

35 X18



28 X18



29 X18

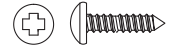

25 X36

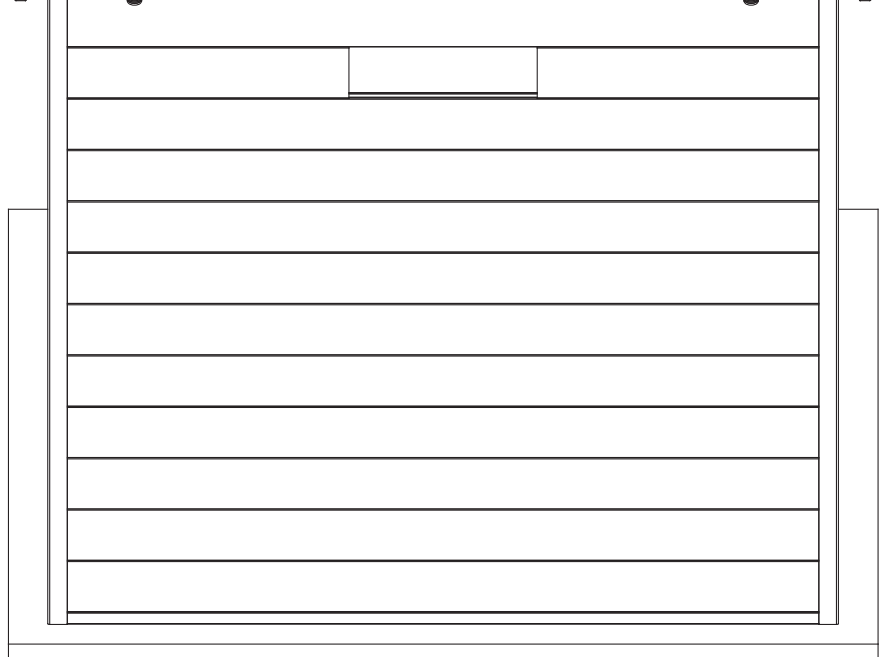
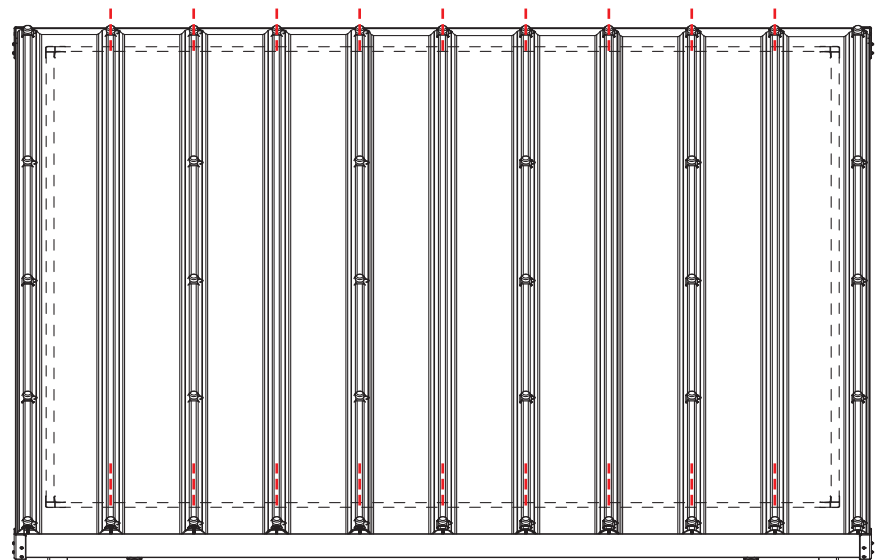
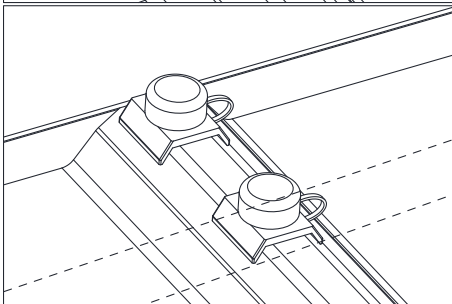
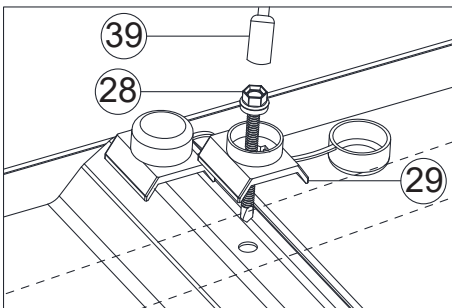
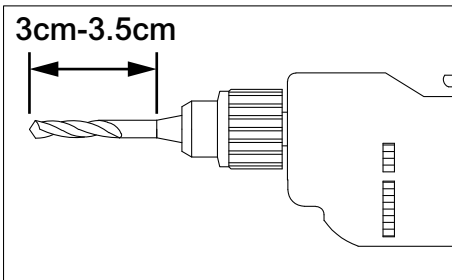
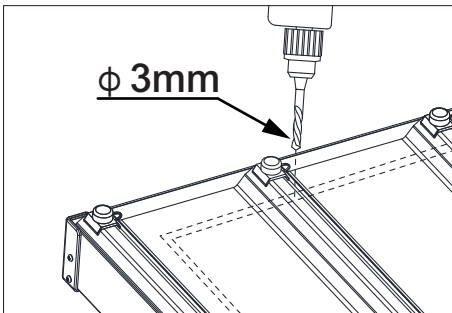
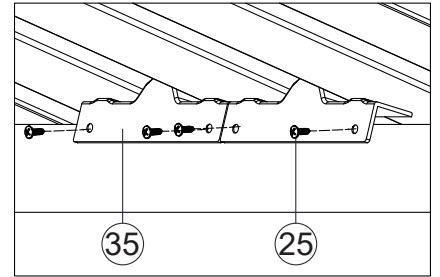
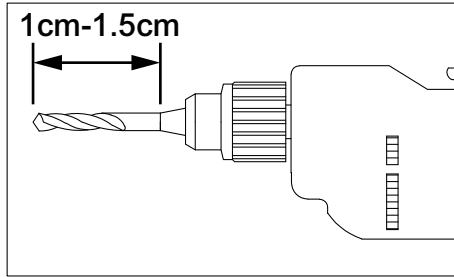
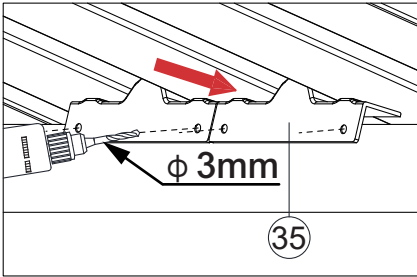
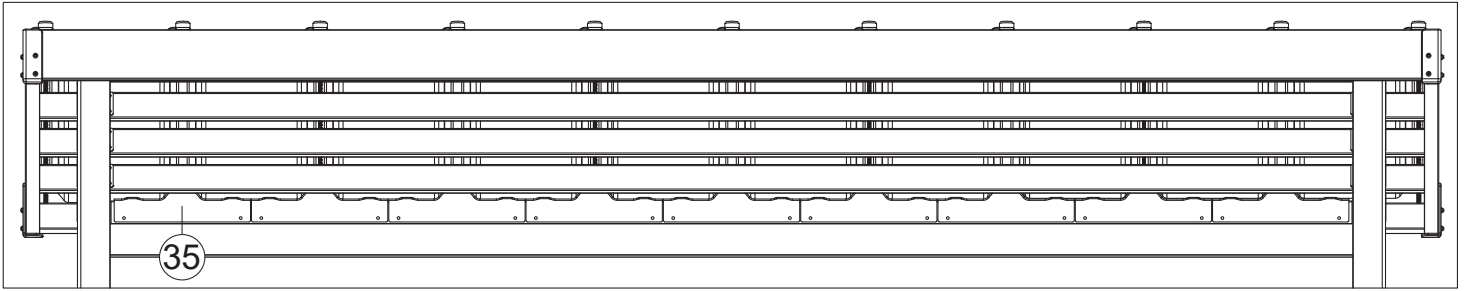

16



34 X1

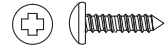

25 X6

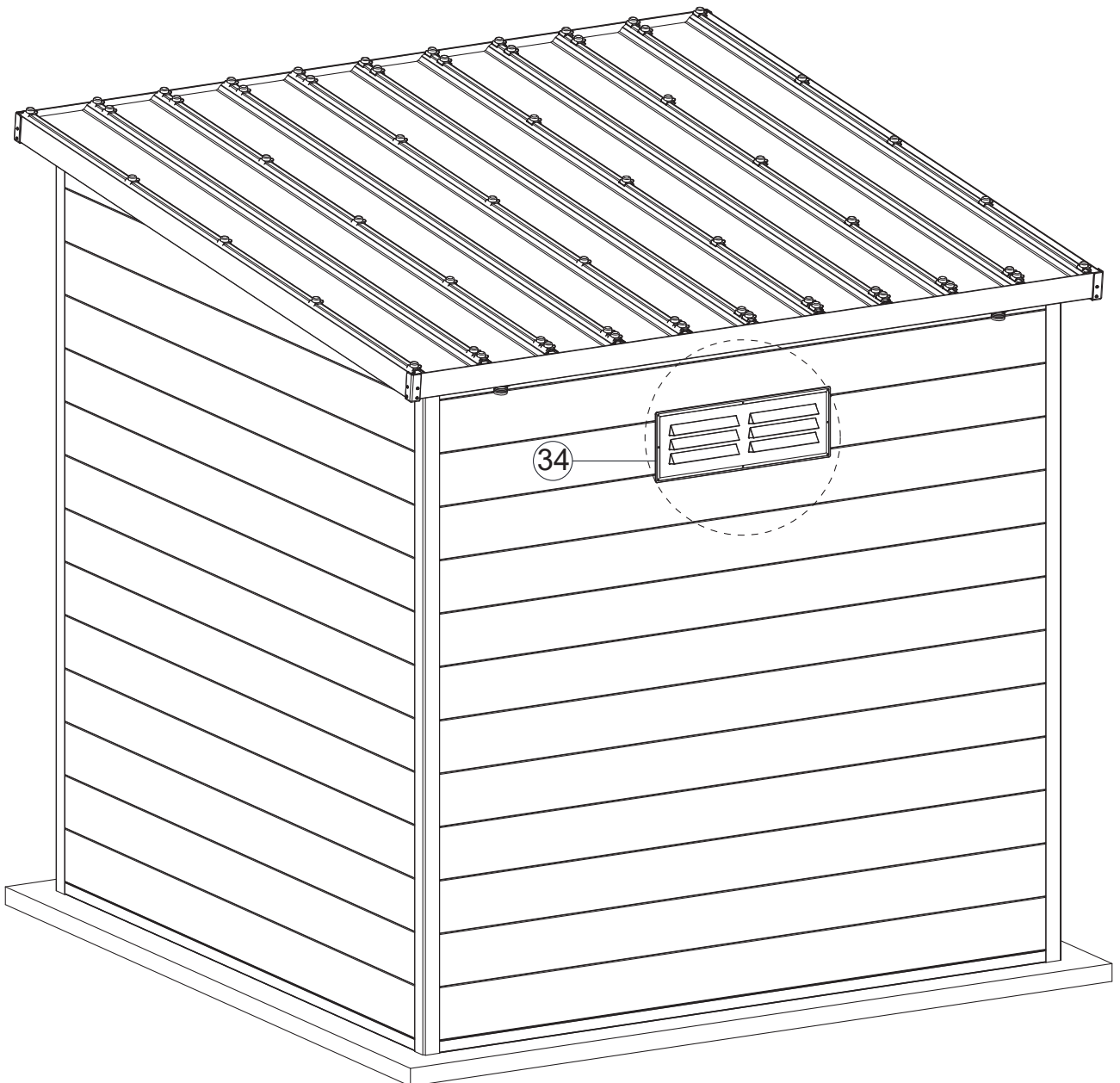
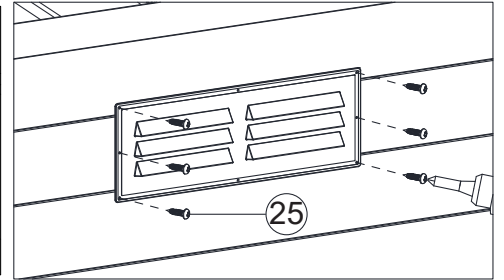
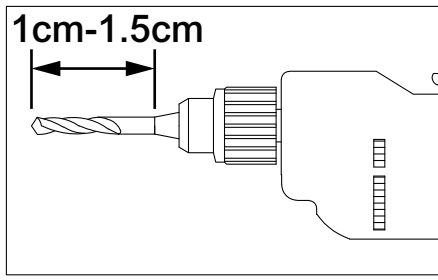
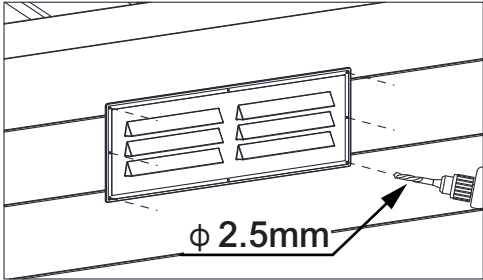

17



26 X12

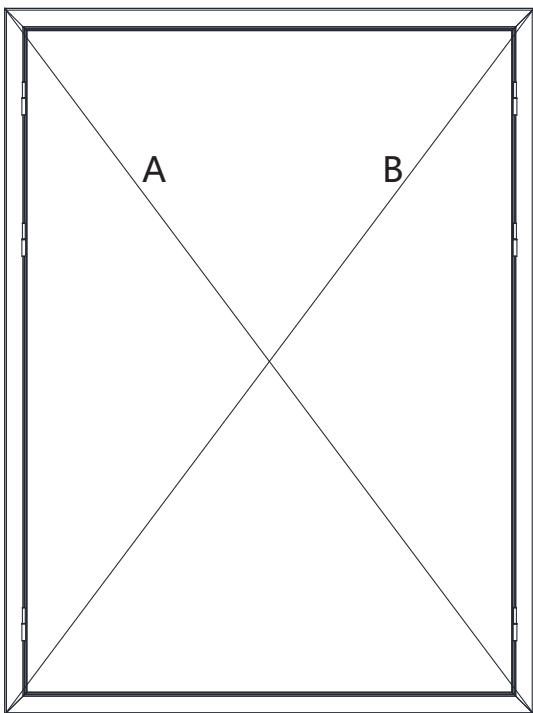
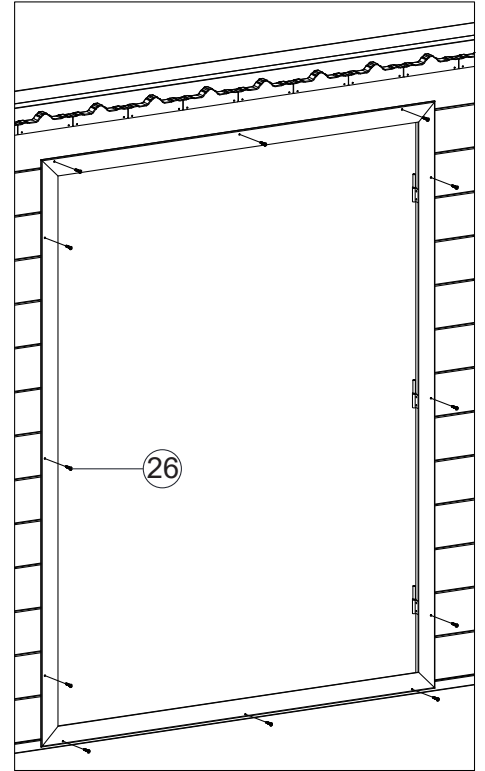
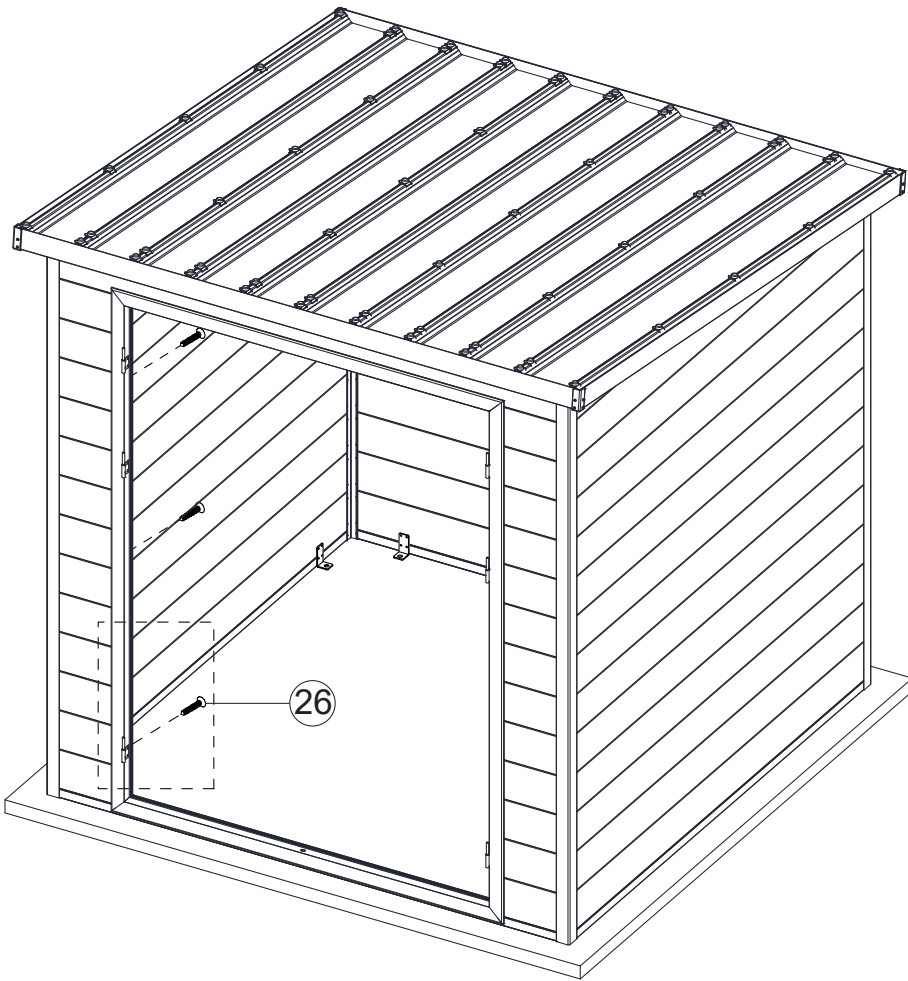

A=B

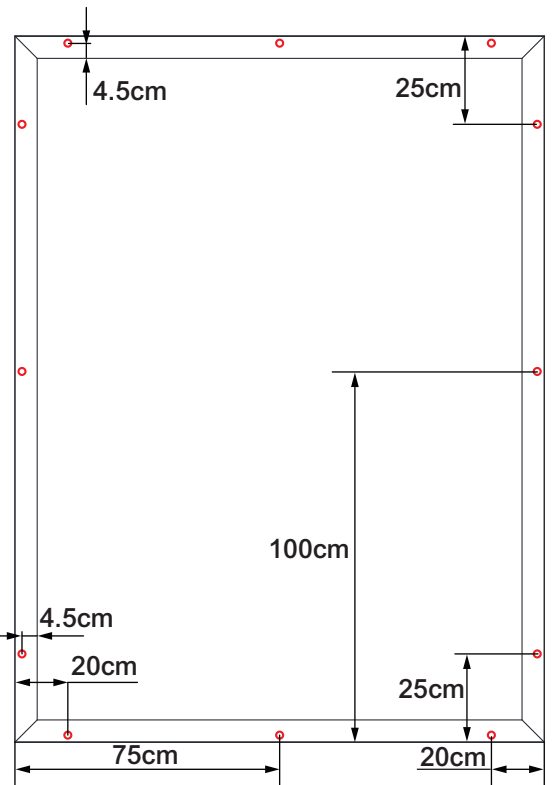
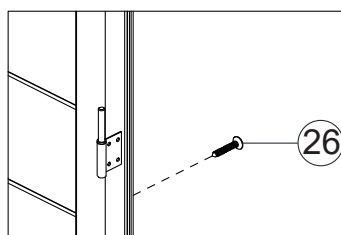
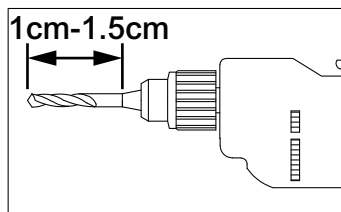
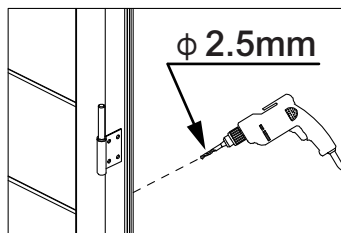

18



32 X1



33 X1

