

Instrucciones de montaje
 Assembly instructions
 Instructions de montage
 Montageanleitung
 Instruções de montagem
 Istruzioni di montaggio

SERVICIO POSTVENTA
 SERVICE APRÈS VENTE
 AFTER SALES SERVICE
 SERVICE NACH DEM VERKAUF
 SERVIÇO PÓS-VENDA
 SERVIZIO DI POST VENDITA



www.mueblespitarch.com
 postventa@mueblespitarch.com

652 851 032 (+34)964 321 111
 8am-1pm 3pm-5:30pm
 de Lunes a viernes/Monday to Friday

Herramientas necesarias/ Tools required / Les outils nécessaires /
 Notwendige Werkzeuge / Ferramentas necessárias / Attrezzatura necessaria

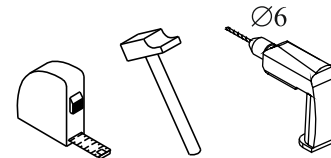

Herrajes incluidos/ Fittings included / Matériel inclus /
 inklusive Hardware / Ferragens incluídos / Ferramenta inclusa

Coldi x 2 Nº710308		Tac x 2 Nº721063		Tor x 2 Nº721118	
-----------------------	--	---------------------	--	---------------------	--

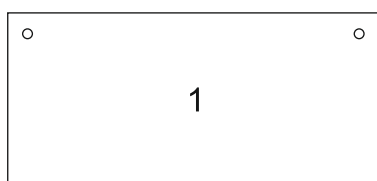

1000x500 mm

REF 14167
 LOTE/ BATCH NUM ***

Te aconsejamos/ We advise you / Nous vous recommandons / Wir beraten Sie / Aconselhamos a / Ti consigliamo:

Ordena y cuenta las piezas y herrajes	Habilita una zona para el montaje	No fuerces los tornillos y los elementos de montaje	Sigue paso a paso las instrucciones de montaje
Order and count the parts and fittings	Enable an area for assembling.	Do not force the screws or assembly parts	Follow the assembly instructions step by step
Commander et compter les pièces et accessoires	Mettre en place un espace de rassemblement	N'utilisez pas de force sur les vis ou les éléments de montage	Suivre les instructions de montage étape par étape
Ordnen und zählen Sie die Teile und Armaturen	Einen Bereich für die Montage einrichten	Wenden Sie keine Gewalt auf Schrauben oder Befestigungselemente an.	Folgen Sie der schrittweisen Montageanleitung
Ordene e conte as peças e ferragens	Estabeleça uma zona de montagem	Não force os parafusos e os elementos de montagem	Siga as instruções de montagem passo-a-passo
Ordina e conta le parti e gli accessori	Adibisci una zona della casa al montaggio	Non forzare le viti e gli elementi da montare, stringendoli eccessivamente.	Segui passo a passo le istruzioni di montaggio

CONDICIONES DE USO Y MANTENIMIENTO

Producto de uso doméstico.
 Evitar colocar el mueble cerca de fuentes de calor, de humedad o de una fuerte luz solar.
 No lo limpie con productos abrasivos, ni disolventes.
 Quitar el polvo antes de limpiarlo.
 Utilizar un paño húmedo, limpio y sin pelos.

CONDITIONS OF USE AND MAINTENANCE OF FURNITURE

Product for domestic use only.
 Avoid placing the furniture near sources of heat, damp, or strong sunlight.
 Do not clean with abrasive products or cleaning products with solvents.
 Use a dust remover before any cleaning process.
 It is recommended to use a damp, lint-free clean cloth.

RECOMENDAÇÕES DE UTILIZAÇÃO E MANUTENÇÃO

Produto para uso doméstico.
 Evitar colocar o mobiliário perto de fontes de calor, humidade ou luz solar forte.
 Não limpar com produtos abrasivos ou solventes.
 Remover o pó antes da limpeza.

LES CONDITIONS D'UTILISATION ET D'ENTRETIEN

Produit à usage domestique.
 Évitez de placer les meubles à proximité de sources de chaleur, d'humidité ou de forte lumière solaire.
 Ne pas nettoyer avec des abrasifs ou des solvants.
 Enlevez la poussière avant le nettoyage.
 Utilisez un chiffon propre et humide.

EINSATZ- UND WARTUNGSBEDINGUNGEN

Produkt für den Hausgebrauch.
 Vermeiden Sie die Aufstellung der Möbel in der Nähe von Wärmequellen, Feuchtigkeit oder starker Sonneneinstrahlung.
 Reinigen Sie nicht mit Scheuermitteln oder Lösungsmitteln.
 Entfernen Sie vor der Reinigung den Staub.
 Sie ein sauberes, feuchtes Tuch.

CONDIZIONI DI USO E MANUTENZIONE

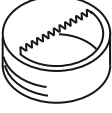

Prodotto per uso domestico. Evitare di installare il mobile vicino a fonti di calore, di umidità o una forte luce solare
 Non pulirlo con prodotti abrasivi né solventi. Togliere la polvere prima di pulirlo
 Usare un panno umido, pulito in cotone o lino ed asciugare subito con un panno morbido

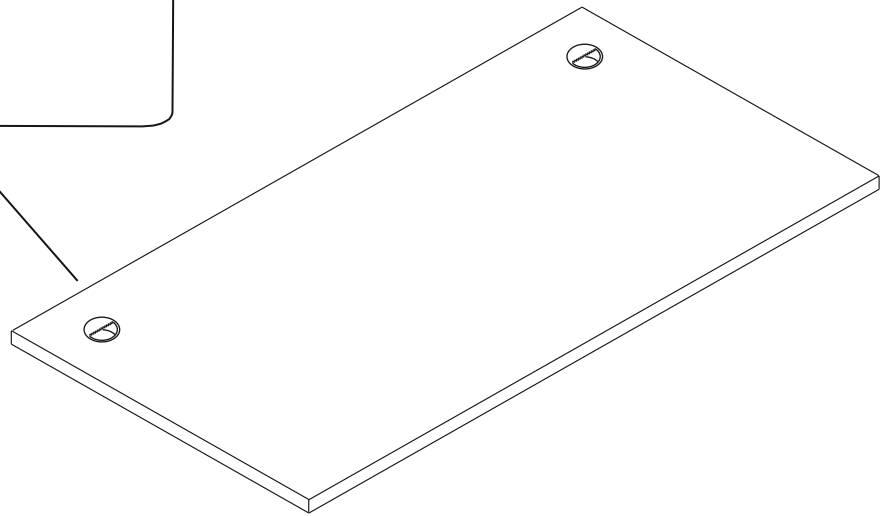
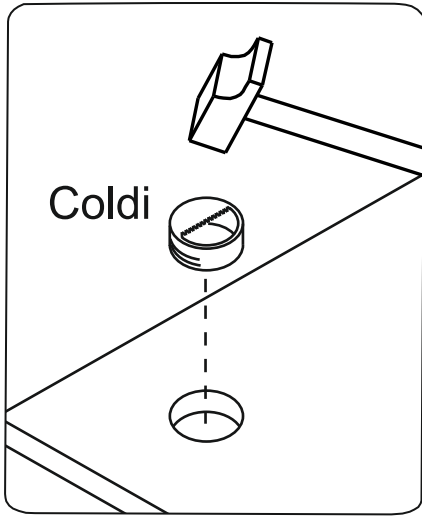
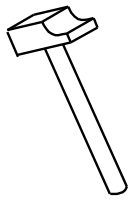
<h1>1</h1>	<p>Coldi x 2</p> 
------------	--

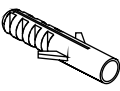
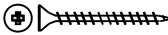

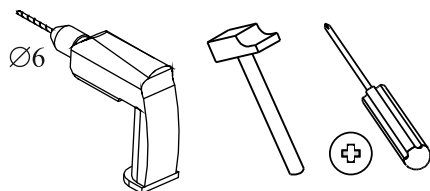
<h1>2</h1>	<p>Tac x 2</p> 	<p>Tor x 2</p> 
------------	--	--

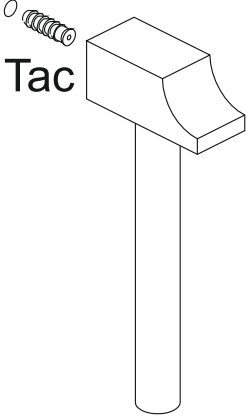

<p>①</p>  <p>Tac</p>	<p>②</p>  <p>Tor</p>
--	---

