

Conjunto de Salón

Móveis de sala - Living room furniture
Ensemble de salon

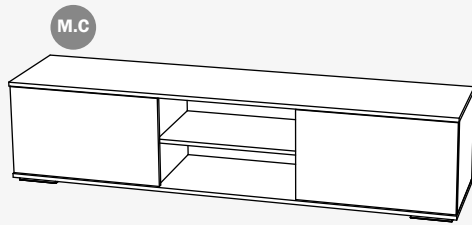
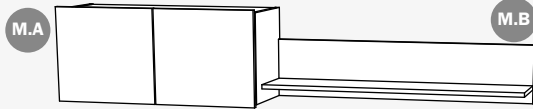

K-501

M.A - 2 puertas
362x800x302

M.B - Balda
220x1.000x236

M.C - 2 puertas + huecos
415x1.800x400

Medidas en mm | Alto x Ancho x Fondo
Dimensões em milímetros: Altura x Largura x Profundidade
Dimensions in millimetres : Height x Width x Depth
Dimensions en millimètres : Hauteur x Largeur x Profondeur



ADVERTENCIAS ANTES DEL MONTAJE

Avisos antes da montagem
Warnings before assembly
Avertissements avant l'assemblage



ES. No ingerir. Agitar antes de usar.

PT. Não ingerir. Agite antes de usar.

EN. Do not swallow. Shake before use.

FR. Ne pas ingérer. Agiter avant utilisation.

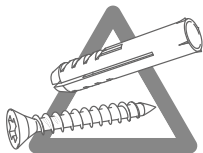

ES. Antes de comenzar con la instalación, es importante que adquieras el sistema de anclaje adecuado para asegurar una fijación segura. Acude a tu ferretería de confianza, donde recibirás asesoramiento sobre las mejores opciones según tus necesidades.

PT. Antes de começar a instalação, é importante escolher o sistema de ancoragem adequado para garantir uma fixação segura. Vá à sua loja de ferragens de confiança, onde receberá orientação sobre as melhores opções de acordo com suas necessidades.

EN. Before starting the installation, it's important to choose the right anchoring system to ensure a secure

attachment. Visit your trusted hardware store, where you'll receive advice on the best options based on your needs.

FR. Avant de commencer l'installation, il est important de choisir le bon système de fixation pour garantir une fixation sécurisée. Rendez-vous dans votre quincaillerie de confiance, où vous recevrez des conseils sur les meilleures options en fonction de vos besoins.

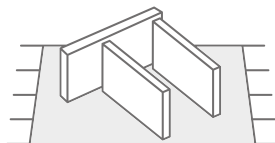

ES. Montaje del mueble sobre una superficie de protección.

PT. Monte os móveis em uma superfície protetora.

EN. Mount the furniture on a protective surface.

FR. Montez le meuble sur une surface de protection.

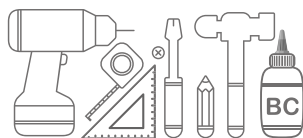

ES. Material necesario para el montaje del mueble.

PT. Material para o qual você deve usar montagem.

EN. Material that you have to use for assembly.

FR. Matériel que vous devez utiliser pour l'assemblage.

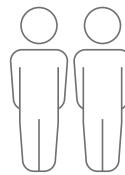

ES. Algunos pasos del montaje requieren de dos personas para su correcta realización.

PT. Alguns etapas exigem 2 pessoas para para sua montagem.

EN. Some assembly steps require two people.

FR. Certaines étapes d'assemblage nécessitent deux personnes.



ES. El montaje del mueble deberá realizarse siguiendo las instrucciones del fabricante, en caso contrario, puede haber riesgo de seguridad por caída o vuelco. Podría provocar lesiones graves.

Siga las siguientes instrucciones de seguridad:

- Evite poner objetos pesados sobre el producto.

- Evite que los niños se apoyen en los cajones o estantes.

- Coloque los objetos más pesados en la parte inferior del mueble.

- Fije el mueble a la pared. En caso contrario puede haber riesgo de seguridad por caída o vuelco que pueden provocar lesiones graves.

Como existen diferentes materiales de pared, no se incluyen los tornillos de montaje ni tacos que anclarán a esta parte. Para encontrar el sistema de sujeción adecuado a su pared póngase en contacto con su especialista más cercano.

PT. Os móveis devem ser montados de acordo com as instruções do fabricante, caso contrário pode haver perigo de queda ou tombamento. Isto pode resultar em ferimentos graves.

As instruções de segurança devem ser seguidas:

- Evitar colocar objetos pesados sobre o mobiliário.

- Evitar que as crianças se inclinem ou trepem em gavetas ou prateleiras.

- Colocar os objetos mais pesados sobre o fundo do mobiliário.

- Fixar o móvel à parede. Caso contrário, pode haver um risco de segurança devido a queda ou tombamento, o que pode causar ferimentos graves.

Como existem diferentes materiais de parede disponíveis, os parafusos de montagem e os tampões de parede que irão ancorar esta parte não estão incluídos. Para encontrar o sistema de fixação correcto para a sua parede, por favor contacte o especialista mais próximo.

EN. The furniture must be assembled in accordance with the manufacturer's instructions, otherwise there may be a safety danger of falling or tipping over. This could result in serious injury.

Safety instructions must be followed:

- Avoid placing heavy objects on the furniture.

- Prevent children from leaning or climbing on drawers or shelves.

- Place the heaviest objects on the bottom of the furniture.

- Secure the cabinet to the wall. Otherwise, there may be a safety risk due to falling or tipping over, which can cause serious injuries.

As there are different wall materials available, the mounting screws and wall plugs that will anchor this part are not included. To find the right fastening system for your wall, please contact your nearest specialist.

FR. Les meubles doivent être montés conformément aux instructions du fabricant, sinon il peut y avoir un risque de chute ou de basculement. Cela pourrait entraîner des blessures graves.

Les consignes de sécurité doivent être respectées :

- Évitez de placer des objets lourds sur le meuble.

- Empêchez les enfants de s'appuyer ou de grimper sur les tiroirs ou les étagères.

- Placez les objets les plus lourds sur le bas du meuble.

- Fixez le meuble au mur. Sinon, il peut y avoir un risque de sécurité en cas de chute ou de basculement, ce qui peut entraîner des blessures graves.

Comme il existe différents matériaux muraux, les vis de montage et les chevilles qui permettront d'ancrer cette pièce ne sont pas fournies. Pour trouver le système de fixation adapté à votre mur, veuillez contacter le spécialiste le plus proche.

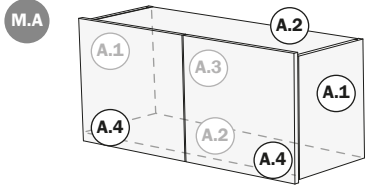

A.1 Costados 342x285x16
Laterais - Sides - Côtés

A.2 Superior e inferior 768x286x16
Superior e inferior - Top and bottom
Haut et bas

A.3 Trasera 782x322x3
Painel Traseiro - Back Panel
Panneau D'Arrière

A.4 Puertas 395x362x16
Portas - Doors - Portes



B.1 Trasera 1000x220x16
Painel Traseiro - Back Panel
Panneau D'Arrière

B.2 Balda 998x220x16
Prateleira - Shelf - Étagère

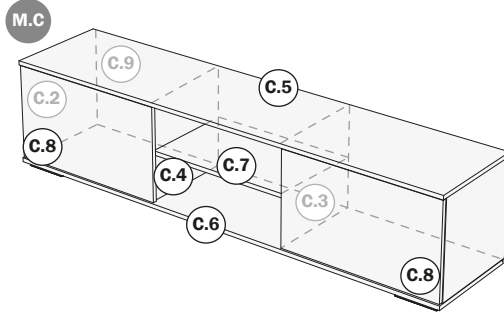

C.1 Costado Derecho 368x380x16
Lateral Derecho - Right Side - Côté Droit

C.2 Costado Izquierdo 368x380x16
Lateral Esquerdo - Light Side - Côté Gauche

C.3 Divisor Derecho 368x366x16
Divisória Direita - Right Divider - Séparateur Droit

C.4 Divisor Izquierdo 368x366x16
Divisória Esquerda - Left Divider - Séparateur Gauche

C.5 Tapa 1800x400x16
Superior - Top - Toit

C.6 Fondo 1800x400x16
Inferior - Bottom - Inférieure

C.7 Estante 576x363x16
Prateleira - Shelf - Étagère

C.8 Puertas 620x362x16
Portas - Doors - Portes

C.9 Trasera 1780x382x3
Painel Traseiro - Back Panel
Panneau D'Arrière

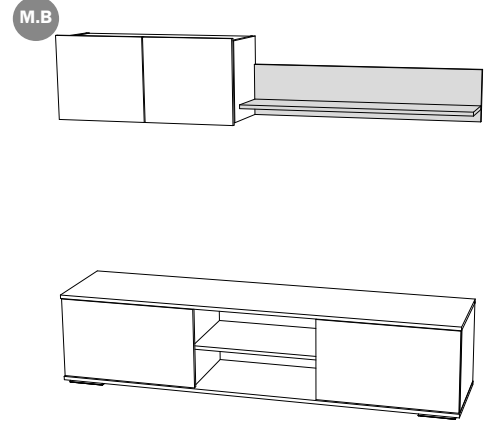
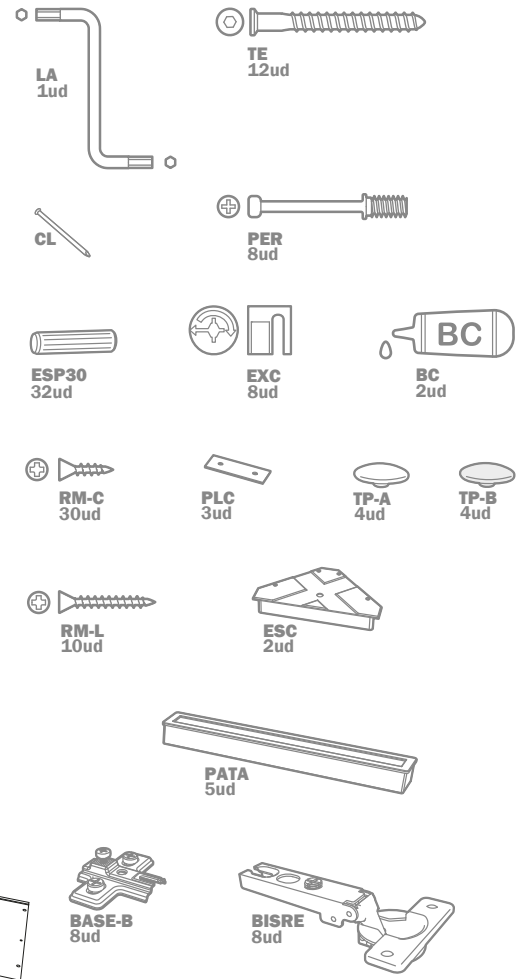

1

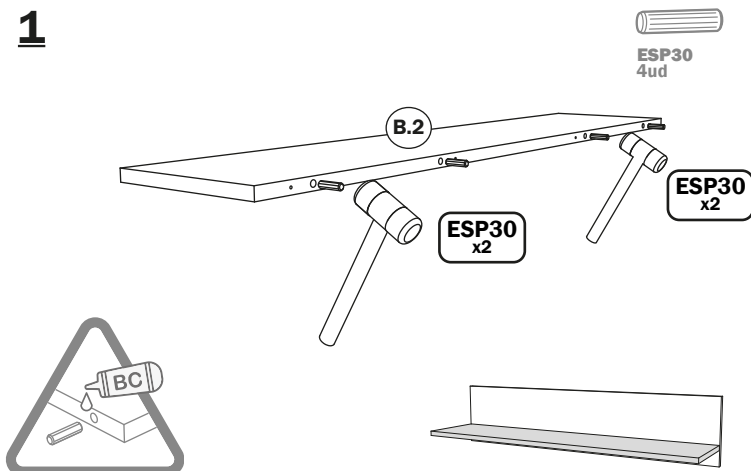

2

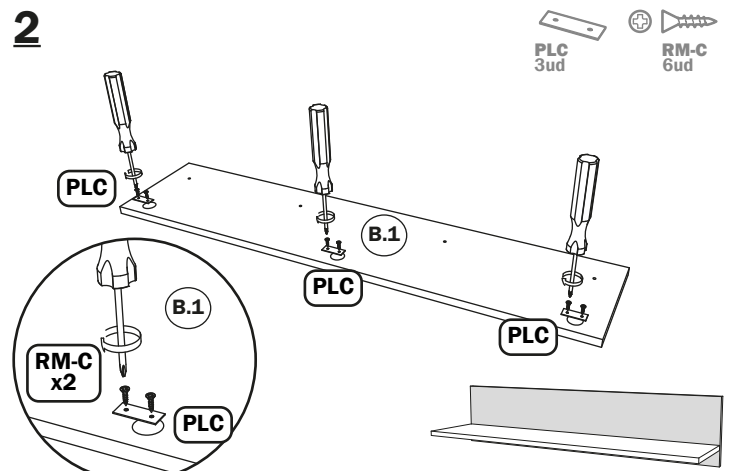

3

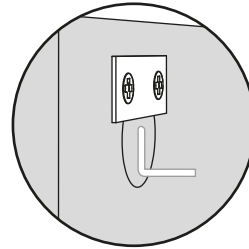
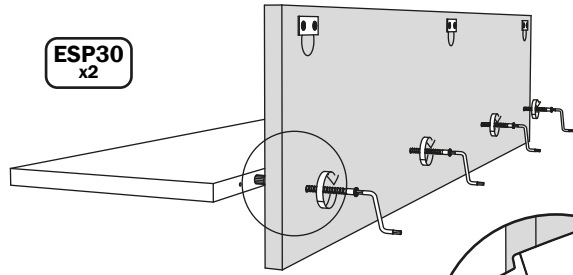

ES. Fije el mueble a la pared con su sistema de fijación elegido.

PT. Fixe o móvel na parede com o sistema de fixação escolhido.

EN. Fix the furniture on the wall using the chosen fixing system.

FR. Fixez le meuble au mur avec le système de fixation choisi.

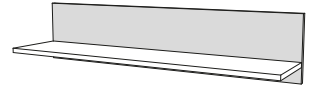
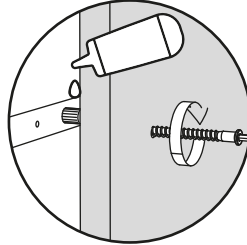

4 (x2)

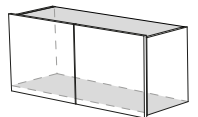
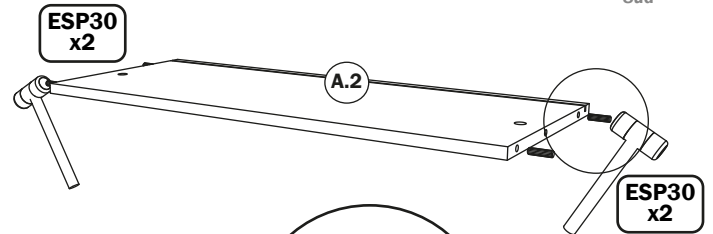
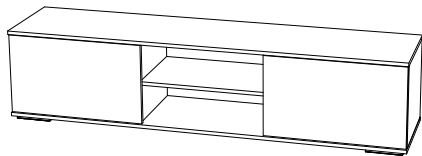
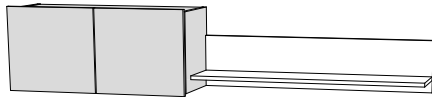

5 (x2)

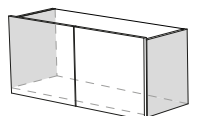
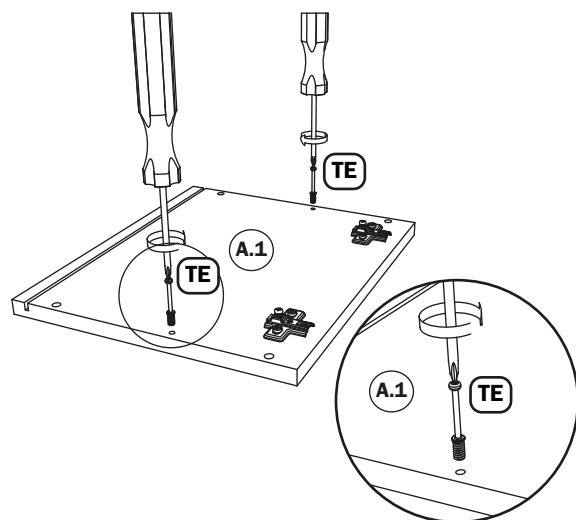
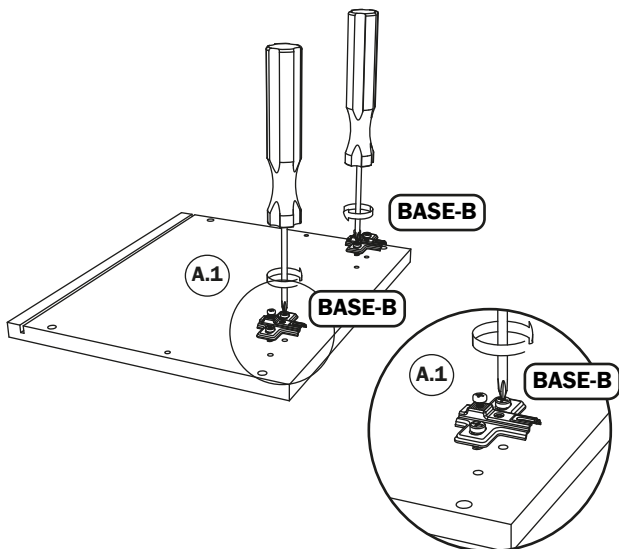

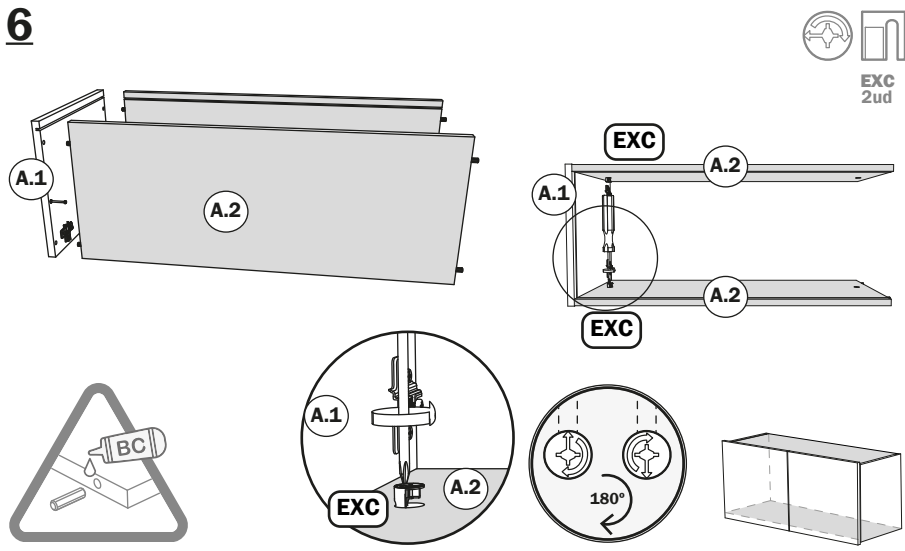
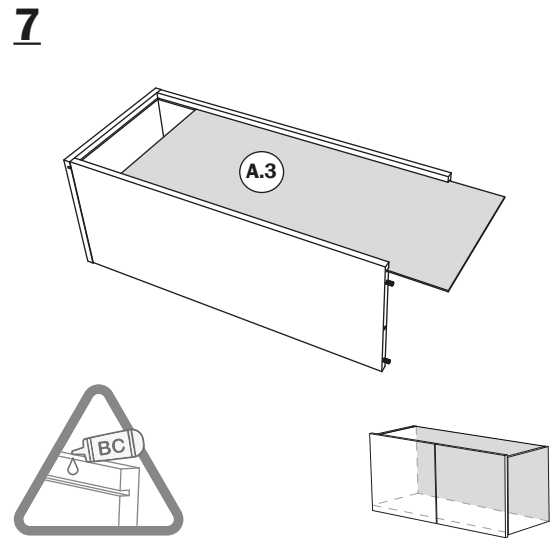
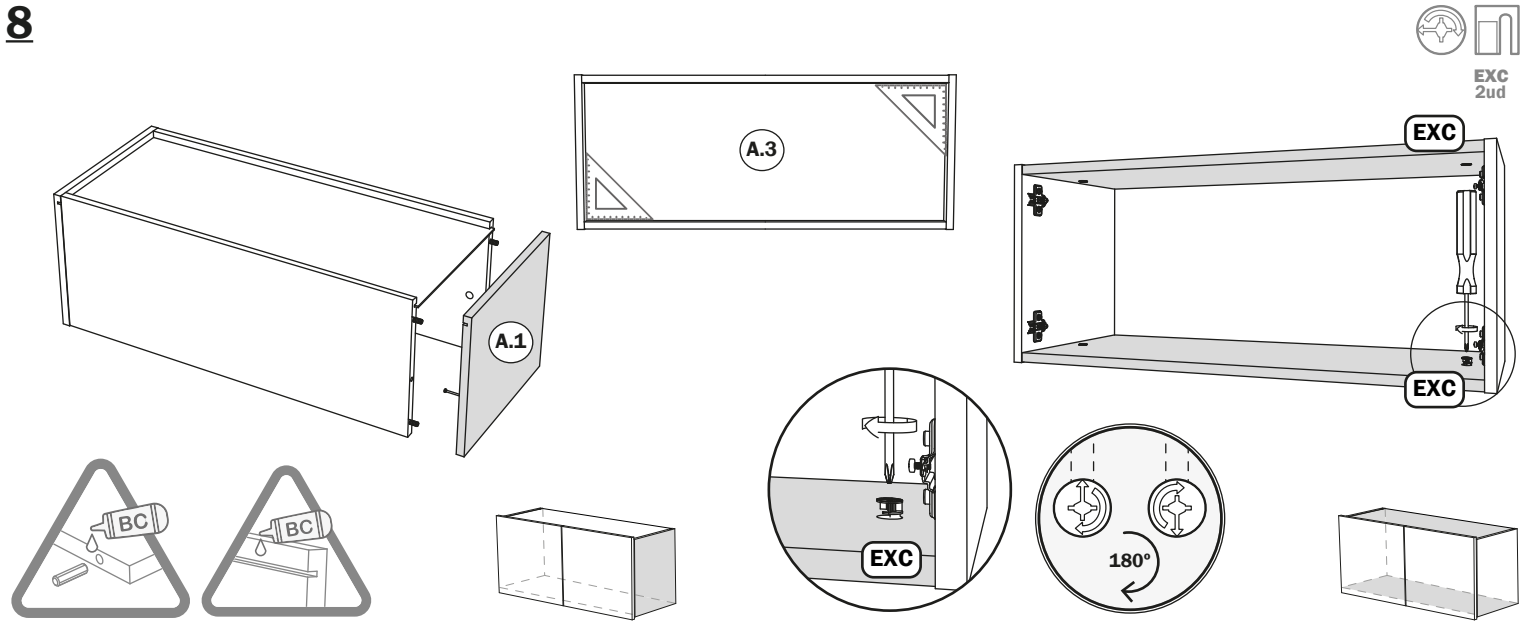
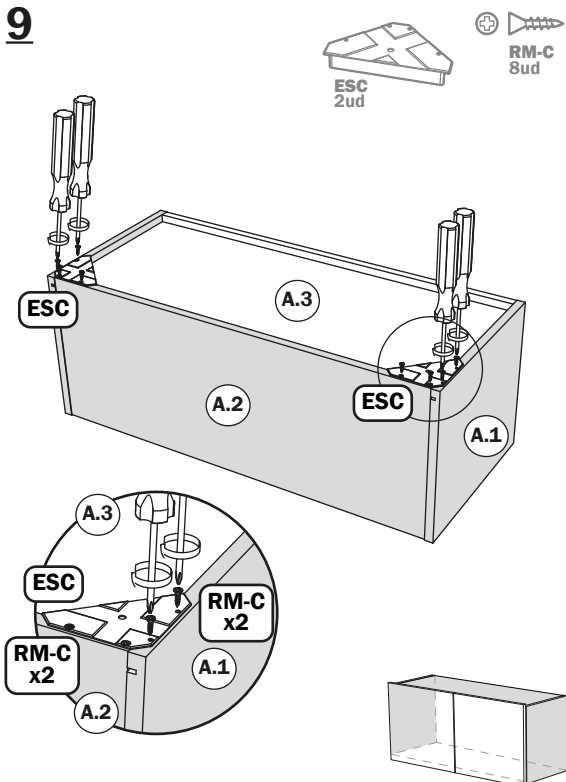
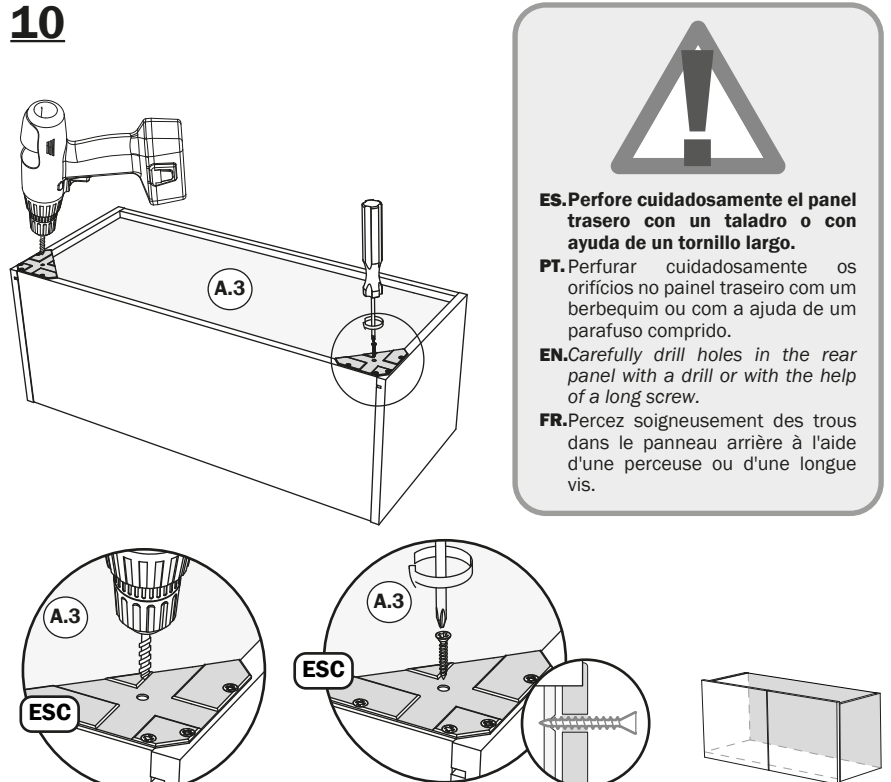
6**7****8****9****10**

11

ES. Fije el mueble a la pared con su sistema de fijación elegido.

PT. Fixe o móvel na parede com o sistema de fixação escolhido.

EN. Fix the furniture on the wall using the chosen fixing system.

FR. Fixez le meuble au mur avec le système de fixation choisi.

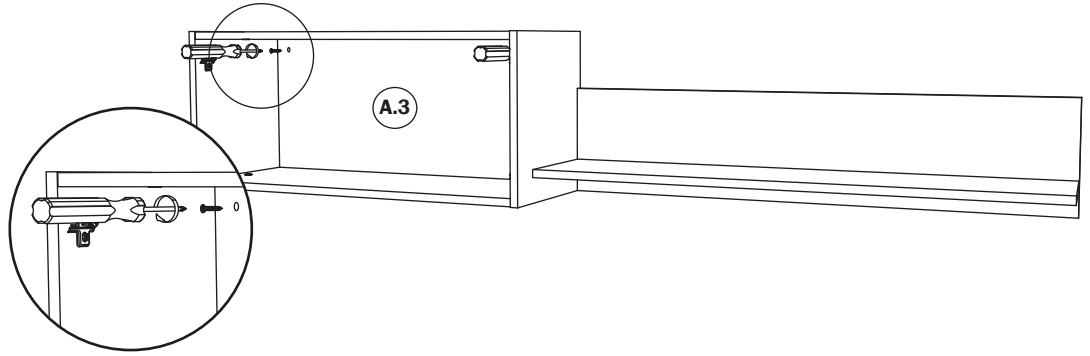

12

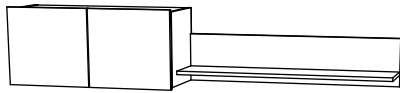
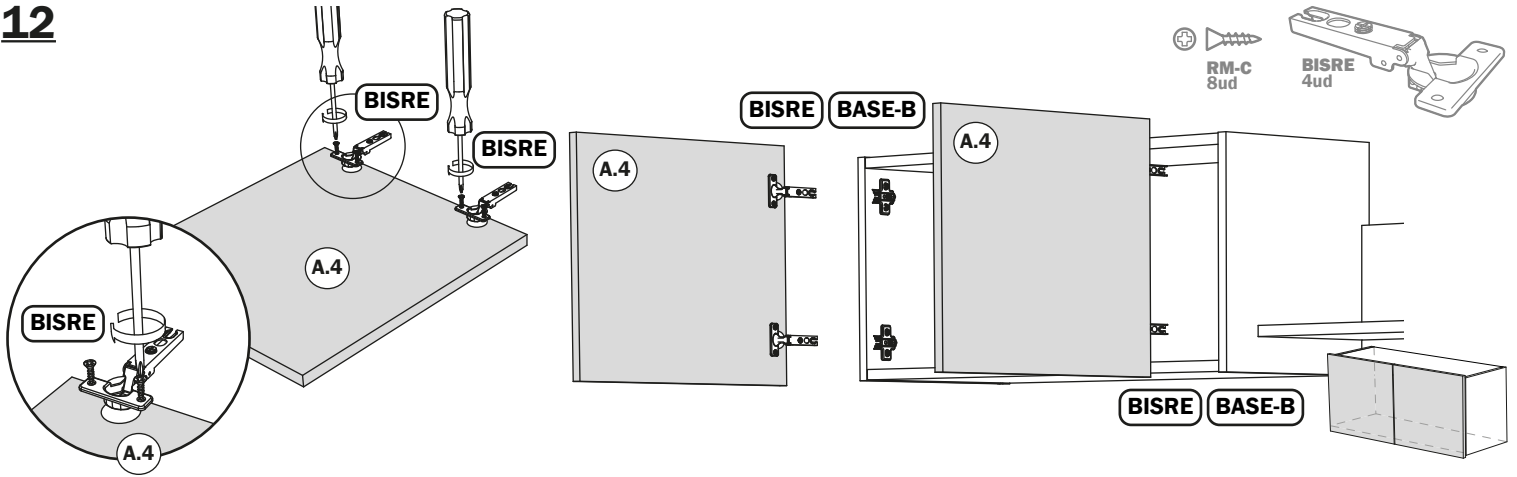

M.C

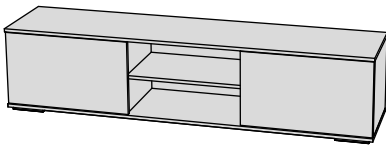

13

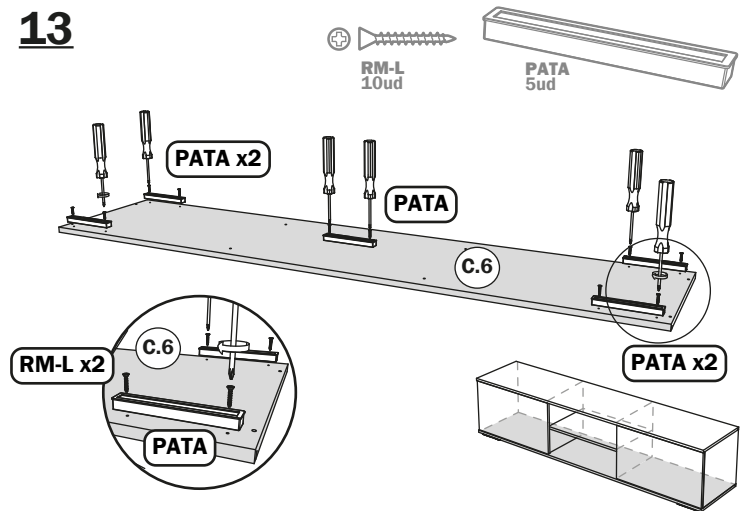

14

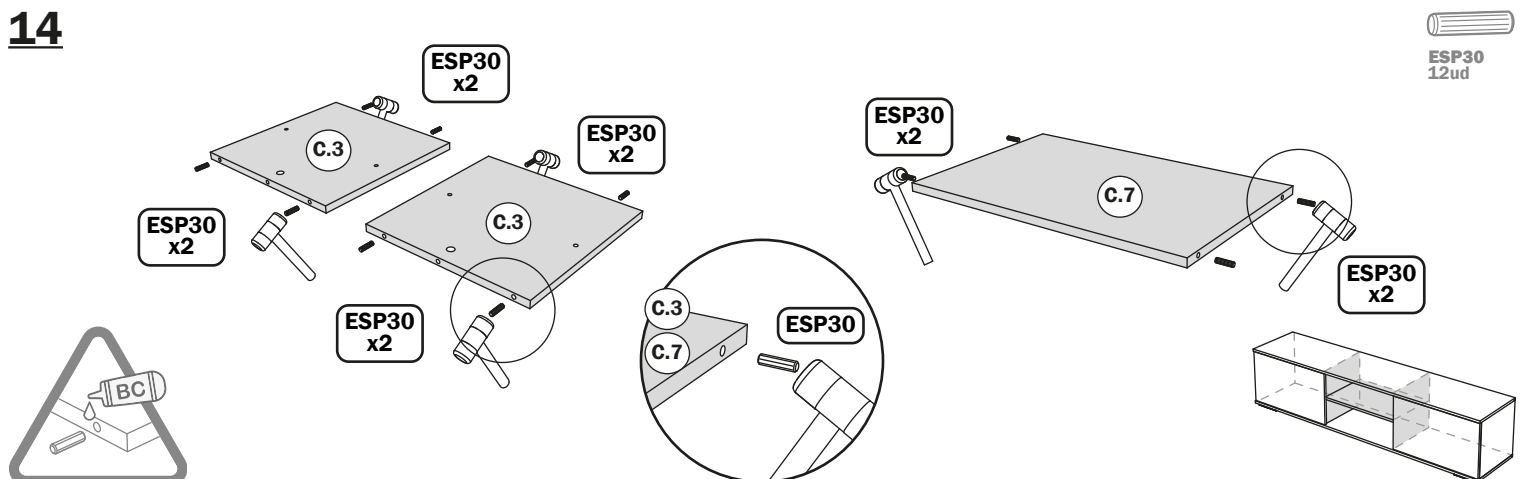

15

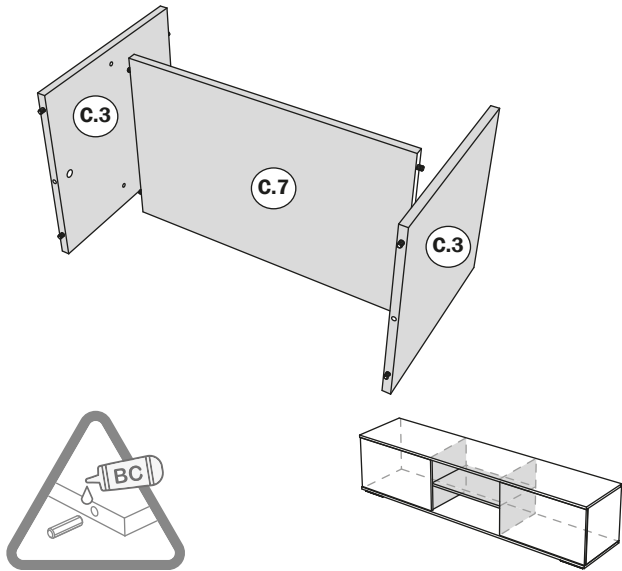

16

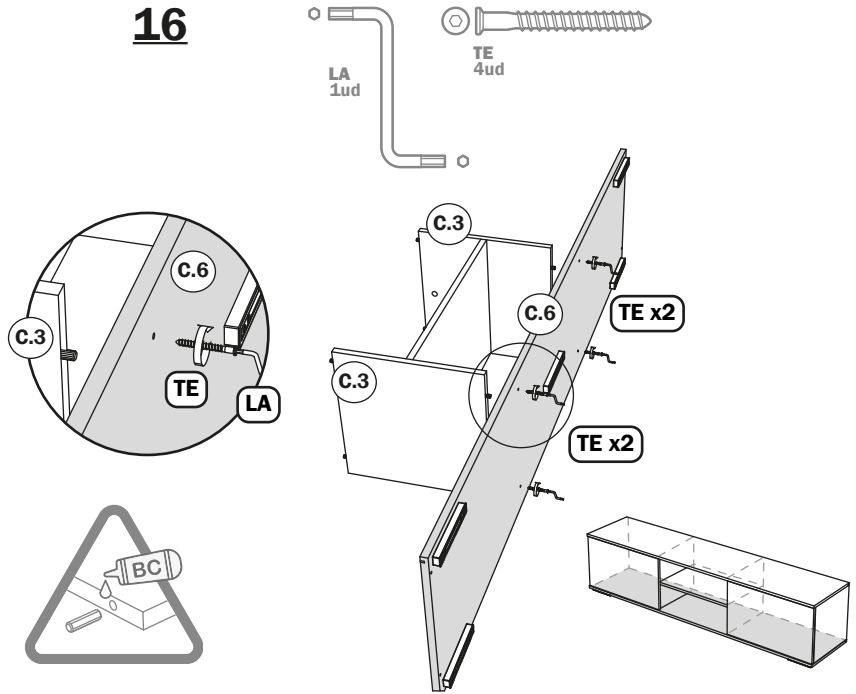

17

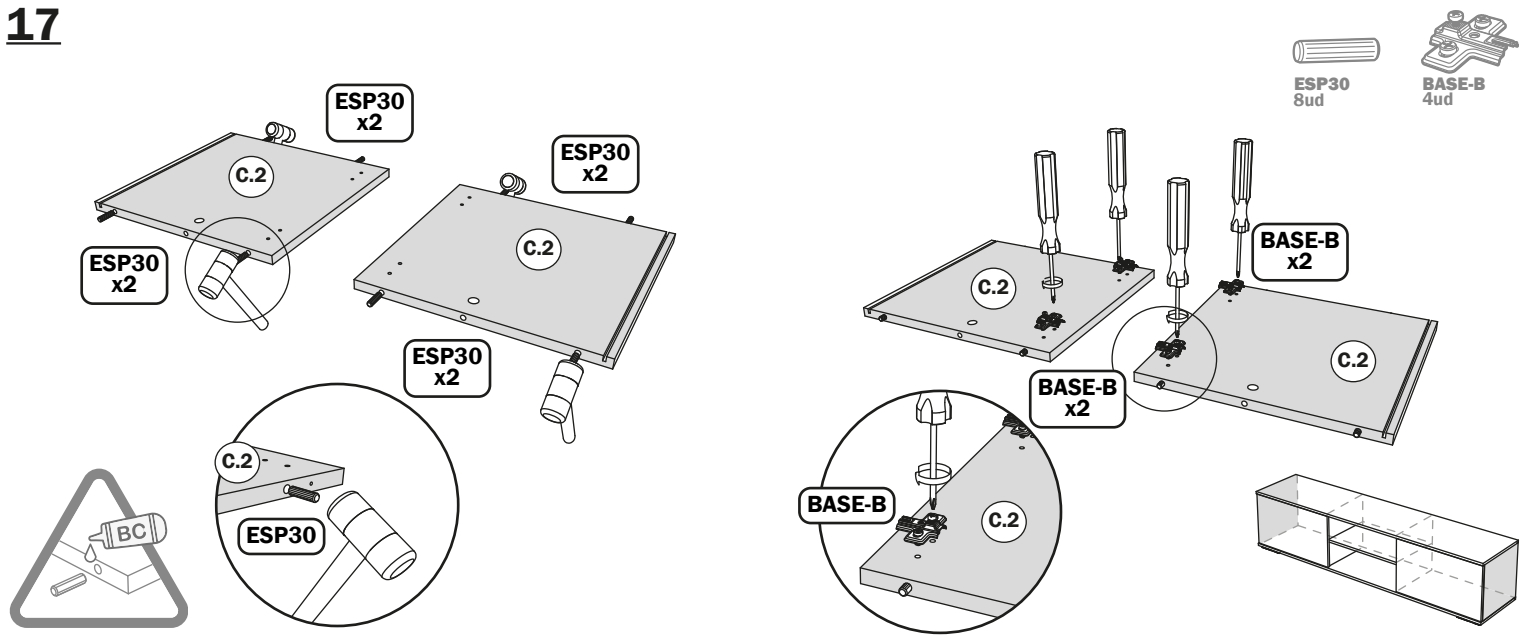

18

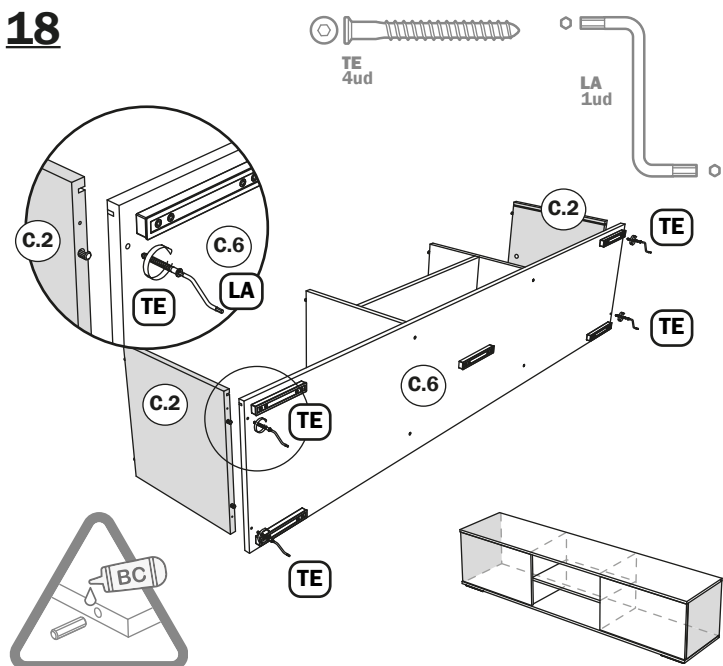

19

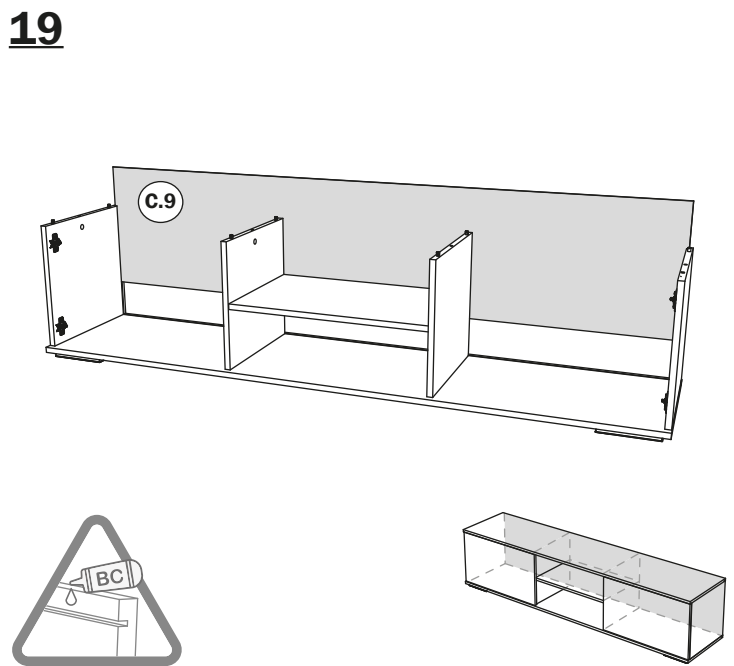

20

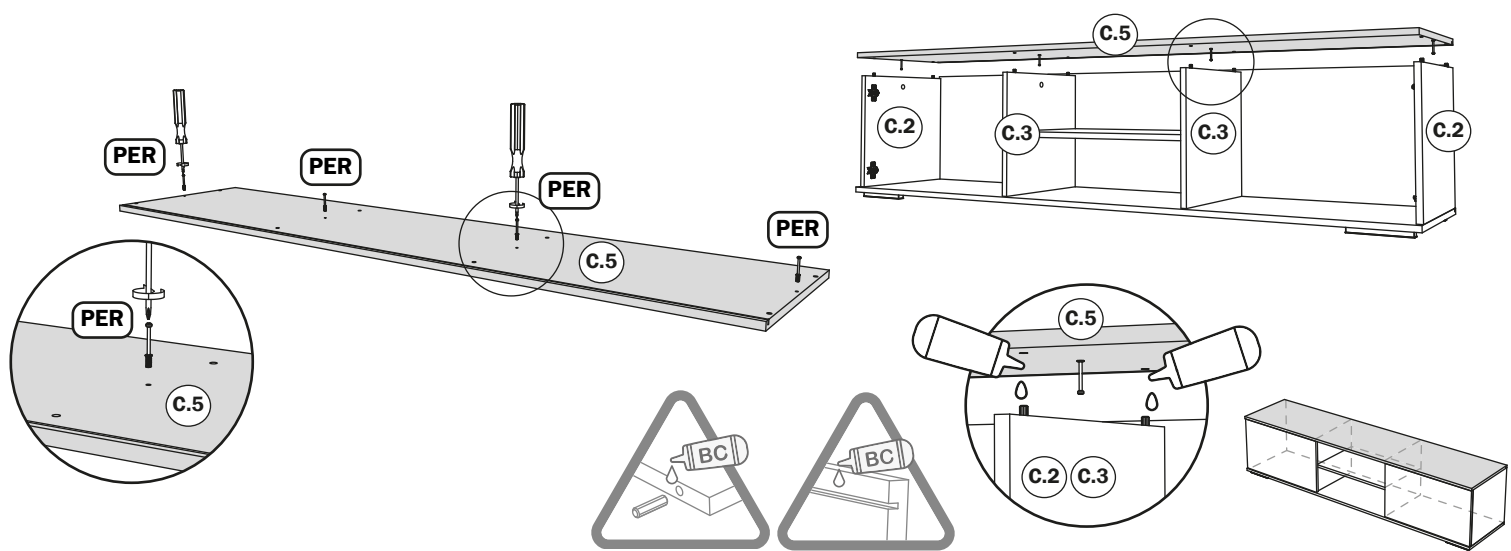

21

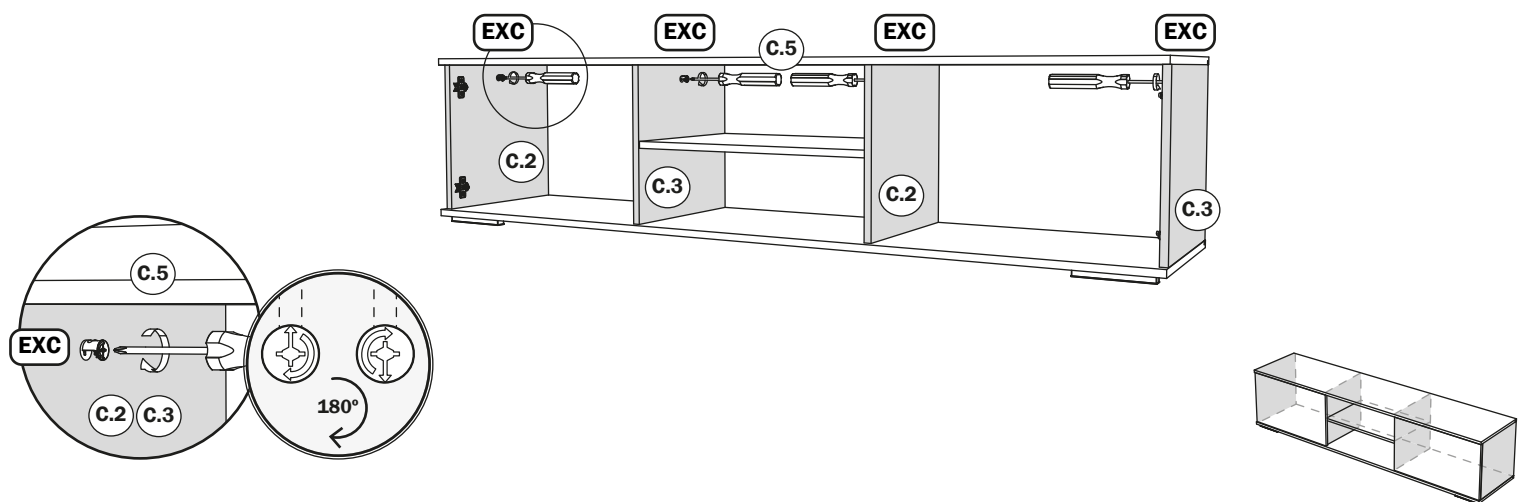

22

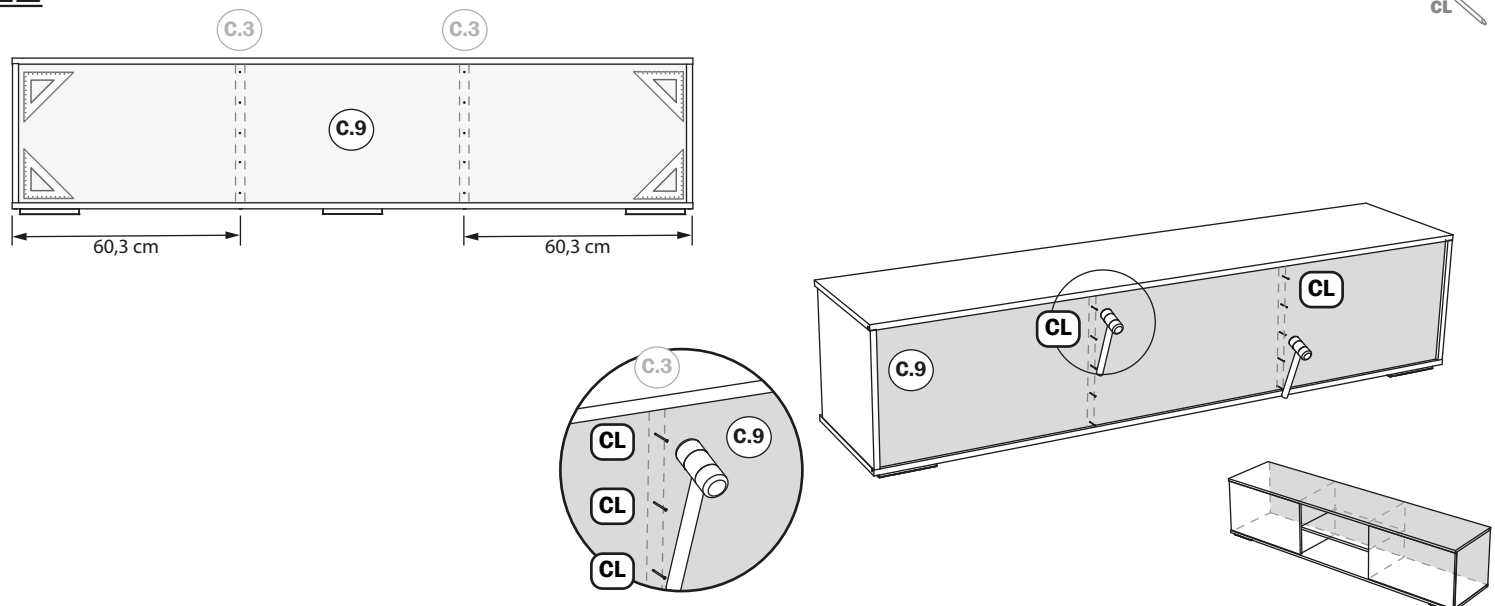

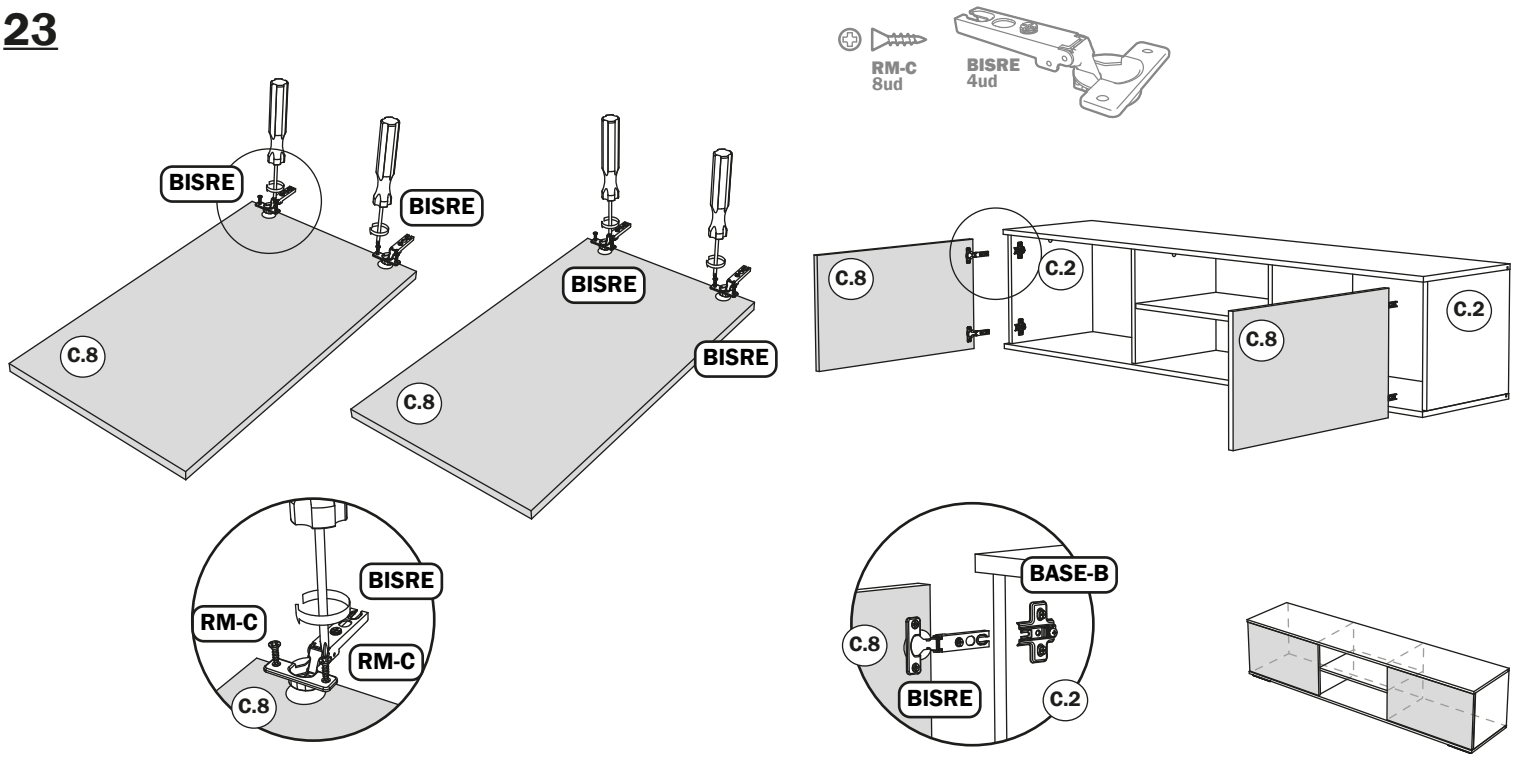

REGULACIÓN DE PUERTAS
REGULAÇÃO DE PORTA - REGULATION DE LA
PORTE - DOOR REGULATION

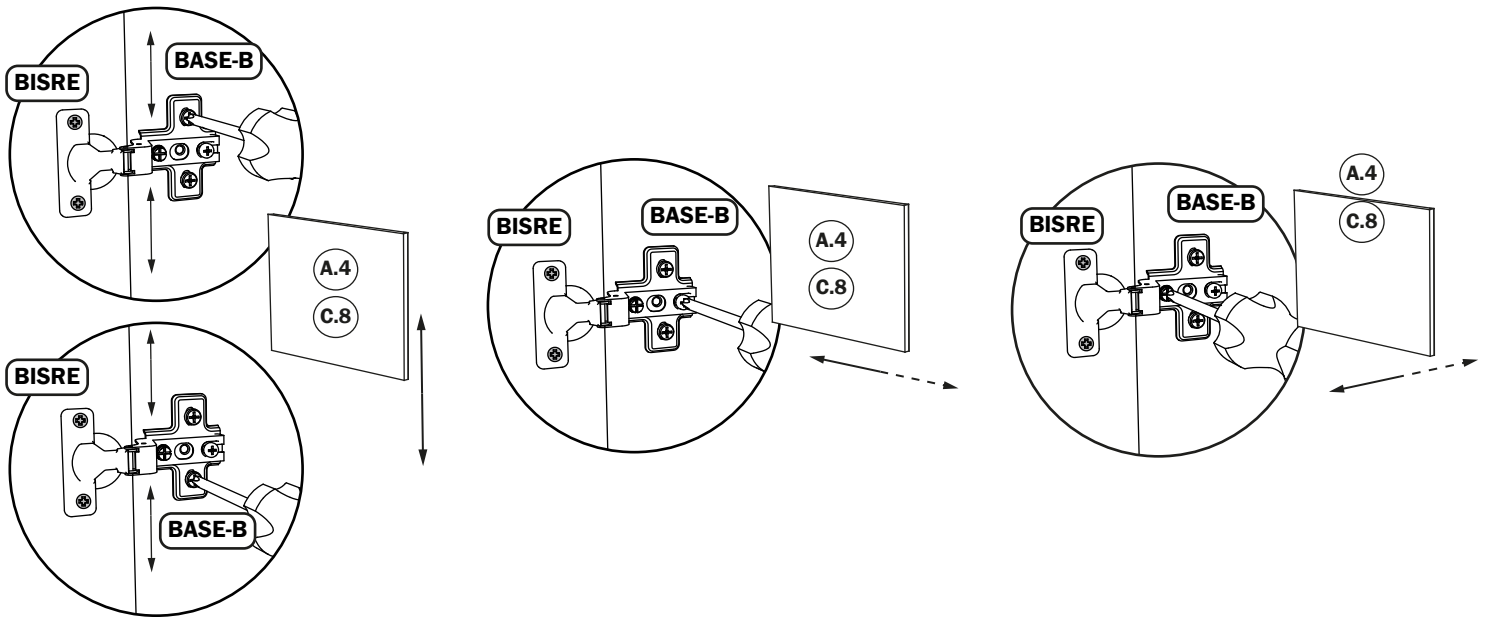

ES Conserve ésta etiqueta para cualquier tipo de reclamación

PT Guarde este rótulo para qualquer tipo de reclamação

EN Keep this label for any requests you may have.

FR Conservez cette étiquette pour tout type de réclamation



COLOR / ACABADO
 K-0000
 O.F. : 23001111

