

CAJONERA

Armário de Gavetas - Drawer Unit - Bloc-Tiroirs

3 Cajones
3 Gavetas
3 Drawers
3 Tiroirs

K-636

Alto: 699mm

Altura - Height - Hauteur

Ancho: 802 mm

Largura - Width - Largeur

Fondo: 480 mm

Profundidade - Depth - Profondeur

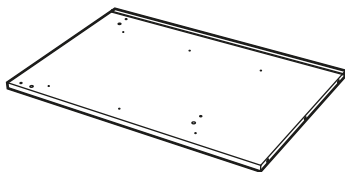
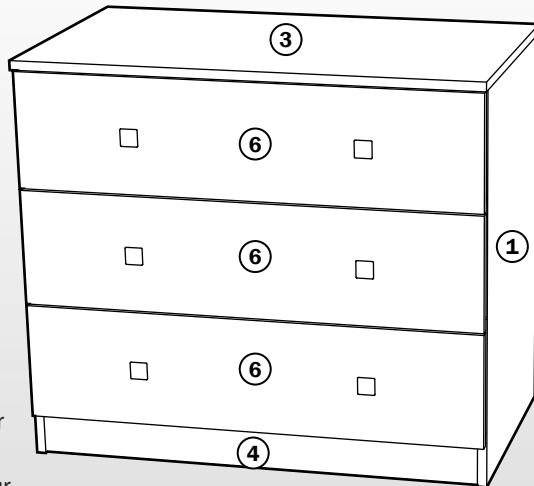

1 Costado Derecho 683x460x16
Lateral Direito - Right Side
Côté Droit

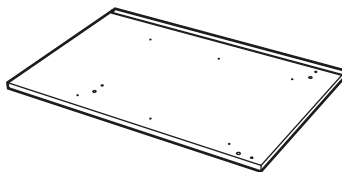

2 Costado Izquierdo 683x460x16
Lateral Esquerdo - Left Side
Côte Gauche

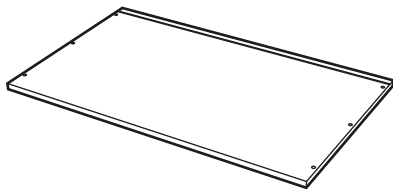

3 Tapa 802x480x16
Superior - Top - Toit

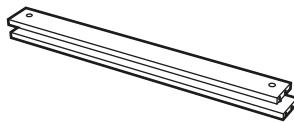

4 Zócalo 767x76x16
Rodapé - Skirting board - Plinthe

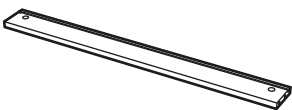

5 Barra 767x76x16
Barra - Bar - Barre

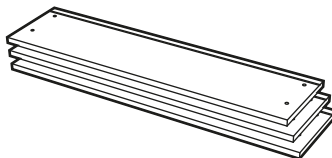

6 Frente de Cajón 794x200x16
Frontal da Gaveta - Drawer Front Panel
Façade de Tiroir

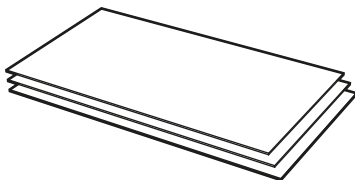

7 Fondo de Cajón 729x398x3
Inferior da Gaveta - Drawer Bottom
Fond du Tiroir

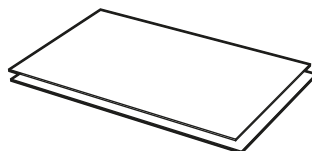

8 Trasera 623x388x3
Painel Traseiro - Back Panel
Panneau D'Arrière

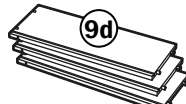
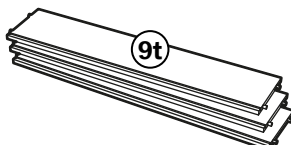
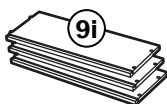

9 Cajón 160x(400x718x400)
Gaveta - Drawer - Tiroir

Servicio de atención al cliente
sac@meka-block.com



ES. No ingerir. Agitar antes de usar.

PT. Não ingerir. Agite antes de usar.

EN. Do not swallow. Shake before use.

FR. Ne pas ingérer. Agiter avant utilisation.

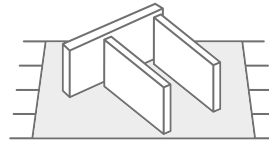

ES. Montaje del mueble sobre una superficie de protección.

PT. Monte os móveis em uma superfície protetora.

EN. Mount the furniture on a protective surface.

FR. Montez le meuble sur une surface de protection.

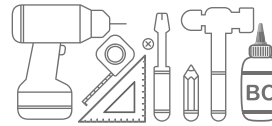

ES. Material necesario para el montaje del mueble.

PT. Material para o qual você deve usar montagem.

EN. Material that you have to use for assembly.

FR. Matériel que vous devez utiliser pour l'assemblage.

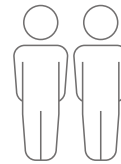

ES. Algunos pasos del montaje requieren de dos personas para su correcta realización.

PT. Alguns etapas exigem 2 pessoas para para sua montagem.

EN. Some assembly steps require two people.

FR. Certaines étapes d'assemblage nécessitent deux personnes.



ES. El montaje del mueble deberá realizarse siguiendo las instrucciones del fabricante, en caso contrario, puede haber riesgo de seguridad por caída o vuelco. Podría provocar lesiones graves.

Siga las siguientes instrucciones de seguridad:

- Evite poner objetos pesados sobre el producto.
- Evite que los niños se apoyen en los cajones o estantes.
- Coloque los objetos más pesados en la parte inferior del mueble.

- Fije el mueble a la pared. En caso contrario puede haber riesgo de seguridad por caída o vuelco que pueden provocar lesiones graves.

Como existen diferentes materiales de pared, no se incluyen los tornillos de montaje ni tacos que anclarán a esta parte. Para encontrar el sistema de sujeción adecuado a su pared póngase en contacto con su especialista mas cercano.

PT. Os móveis devem ser montados de acordo com as instruções do fabricante, caso contrário pode haver perigo de queda ou tombamento. Isto pode resultar em ferimentos graves.

As instruções de segurança devem ser seguidas:

- Evitar colocar objectos pesados sobre o mobiliário.
- Evitar que as crianças se inclinem ou trepem em gavetas ou prateleiras.
- Colocar os objectos mais pesados sobre o fundo do mobiliário.
- Fixar o móvel à parede. Caso contrário, pode haver um risco de segurança devido a queda ou tombamento, o que pode causar ferimentos graves.

Como existem diferentes materiais de parede disponíveis, os parafusos de montagem e os tampões de parede que irão ancorar esta parte não estão incluídos. Para encontrar o sistema de fixação correcto para a sua parede, por favor contacte o especialista mais próximo.

EN. The furniture must be assembled in accordance with the manufacturer's instructions, otherwise there may be a safety danger of falling or tipping over. This could result in serious injury.

Safety instructions must be followed:

- Avoid placing heavy objects on the furniture.
- Prevent children from leaning or climbing on drawers or shelves.
- Place the heaviest objects on the bottom of the furniture.
- Secure the cabinet to the wall. Otherwise, there may be a safety risk due to falling or tipping over, which can cause serious injuries.

As there are different wall materials available, the mounting screws and wall plugs that will anchor this part are not included. To find the right fastening system for your wall, please contact your nearest specialist.

FR. Les meubles doivent être montés conformément aux instructions du fabricant, sinon il peut y avoir un risque de chute ou de basculement. Cela pourrait entraîner des blessures graves.

Les consignes de sécurité doivent être respectées :

- Évitez de placer des objets lourds sur le meuble.
- Empêchez les enfants de s'appuyer ou de grimper sur les tiroirs ou les étagères.
- Placez les objets les plus lourds sur le bas du meuble.
- Fixez le meuble au mur. Sinon, il peut y avoir un risque de sécurité en cas de chute ou de basculement, ce qui peut entraîner des blessures graves.

Comme il existe différents matériaux muraux, les vis de montage et les chevilles qui permettront d'ancrer cette pièce ne sont pas fournies. Pour trouver le système de fixation adapté à votre mur, veuillez contacter le spécialiste le plus proche.

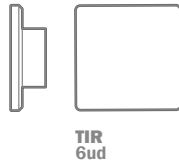

GE 3jg

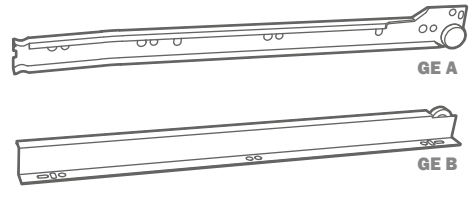

1

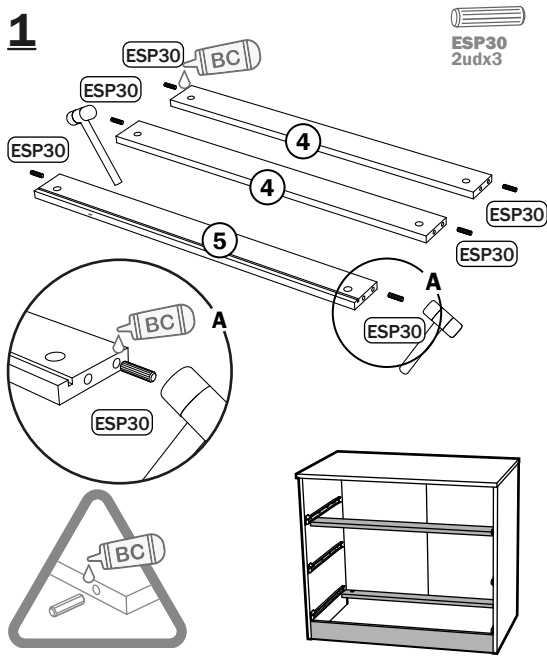

2

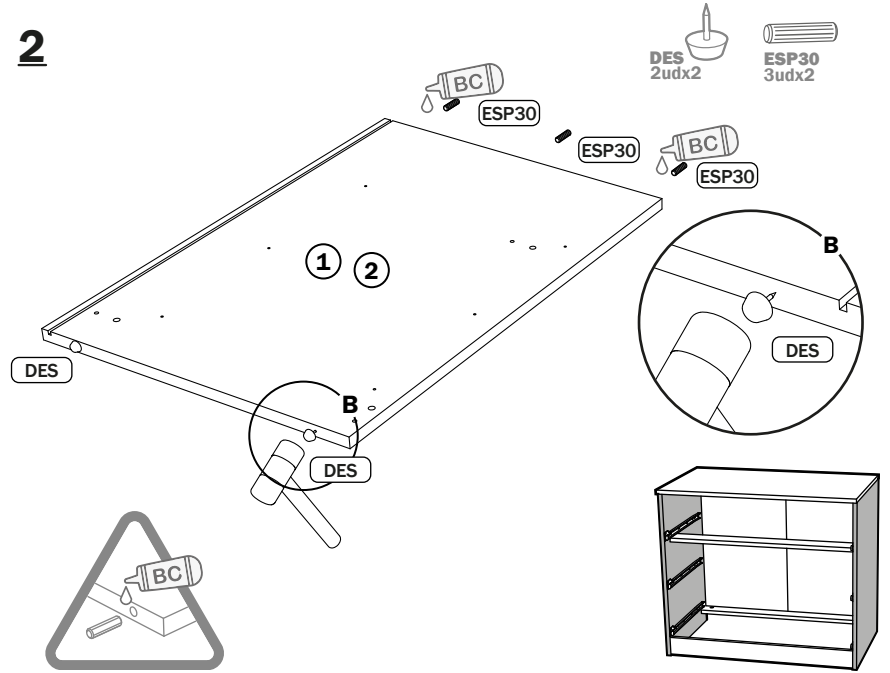

3

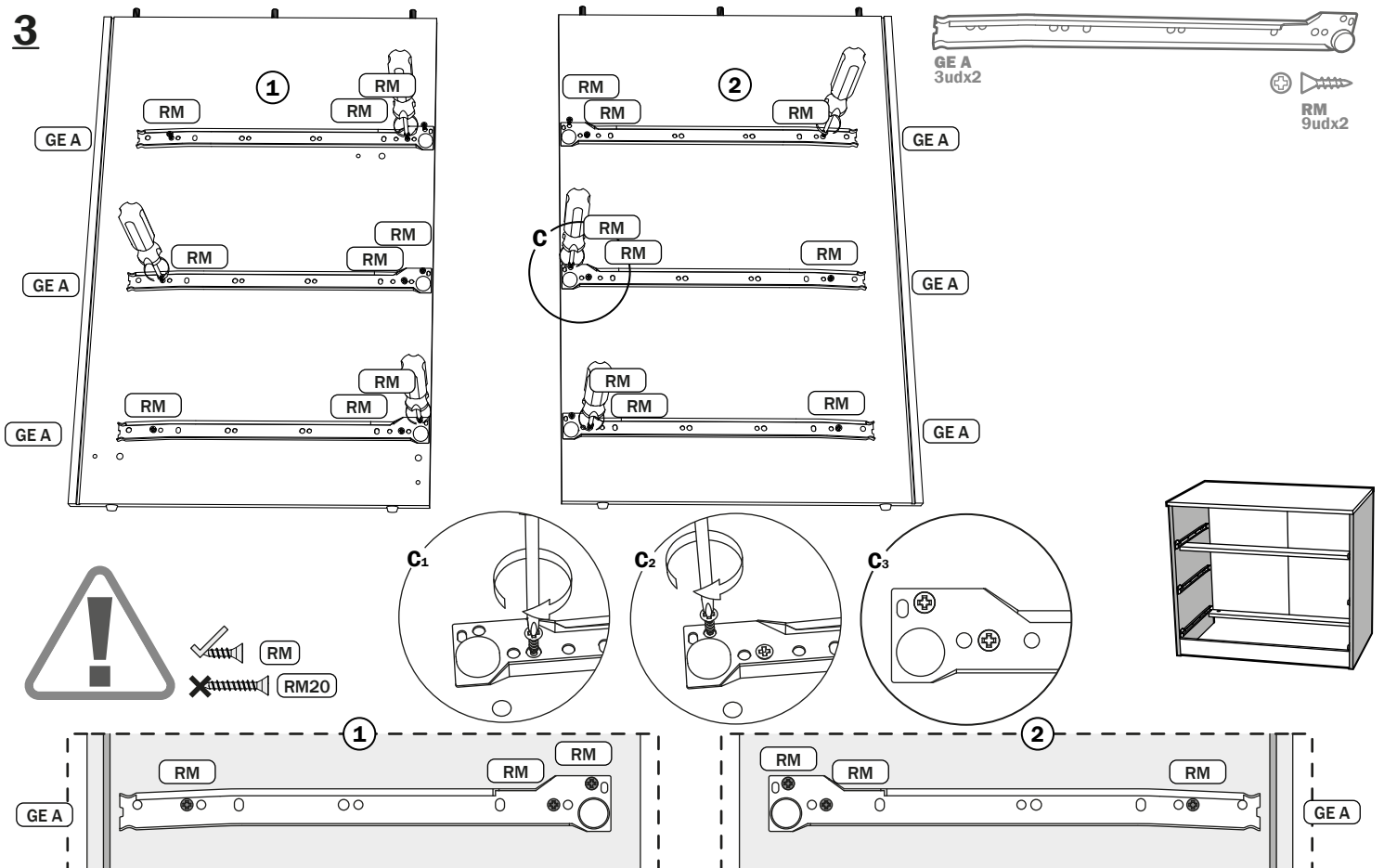

Este artículo dispone de una garantía según los términos y condiciones expresados por la ley.

Este artigo possui uma garantia de acordo com os termos e condições expressos em Lei.

4

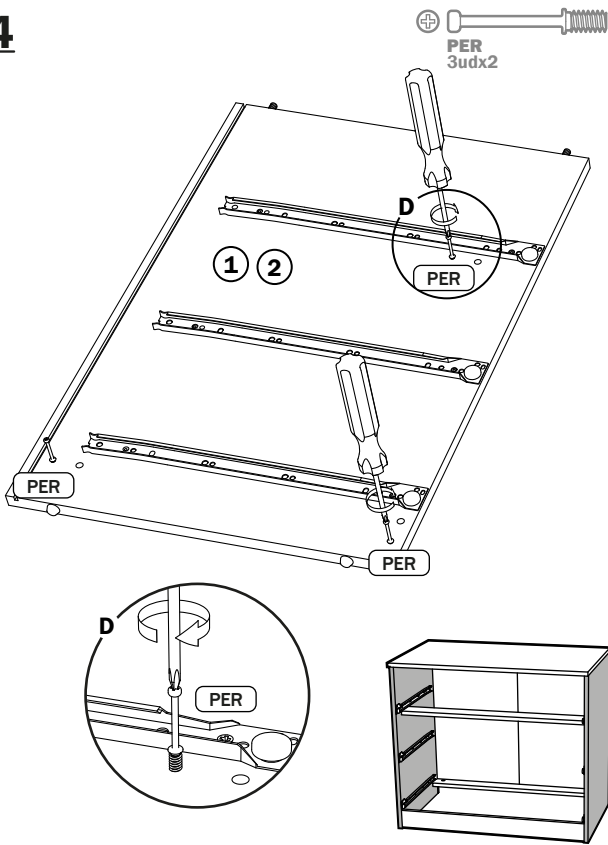

5

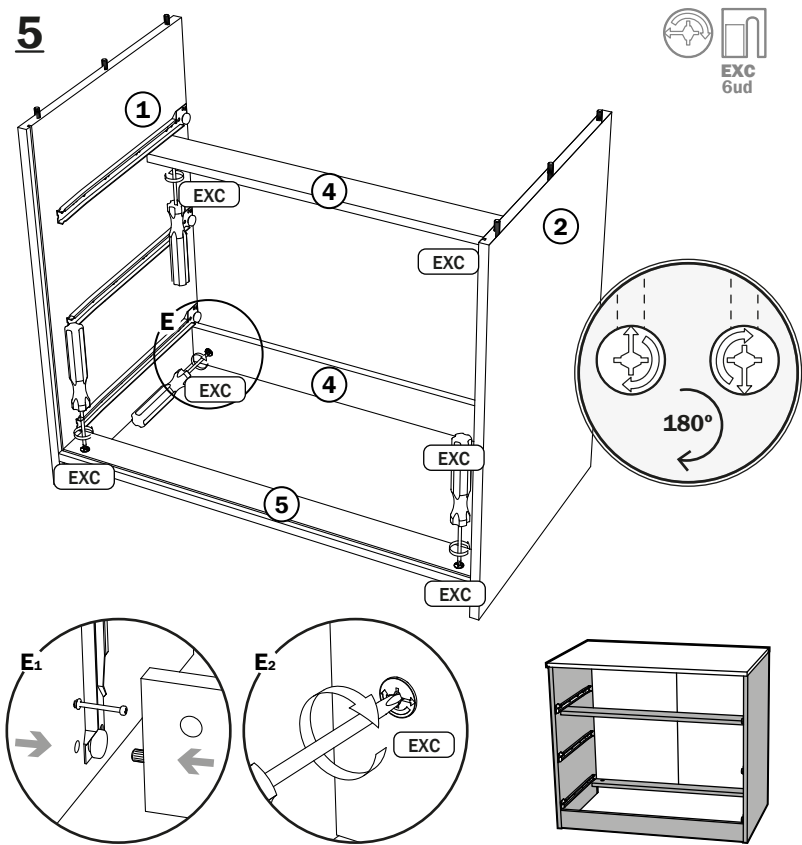

6

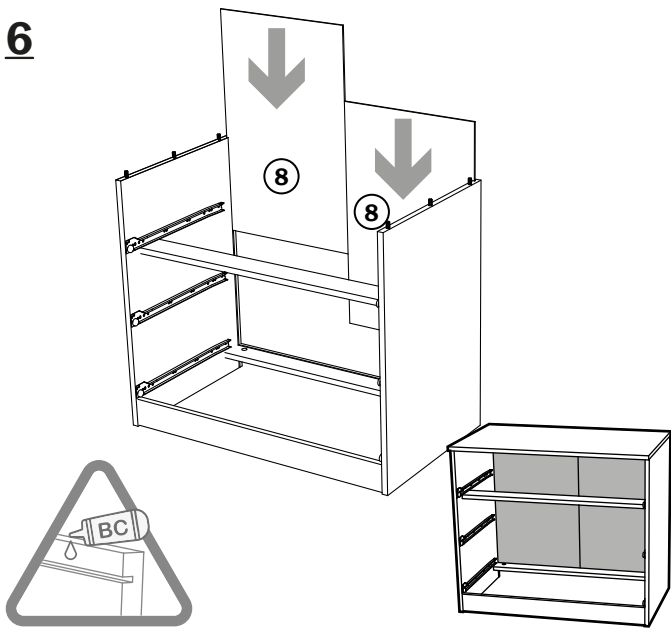

7

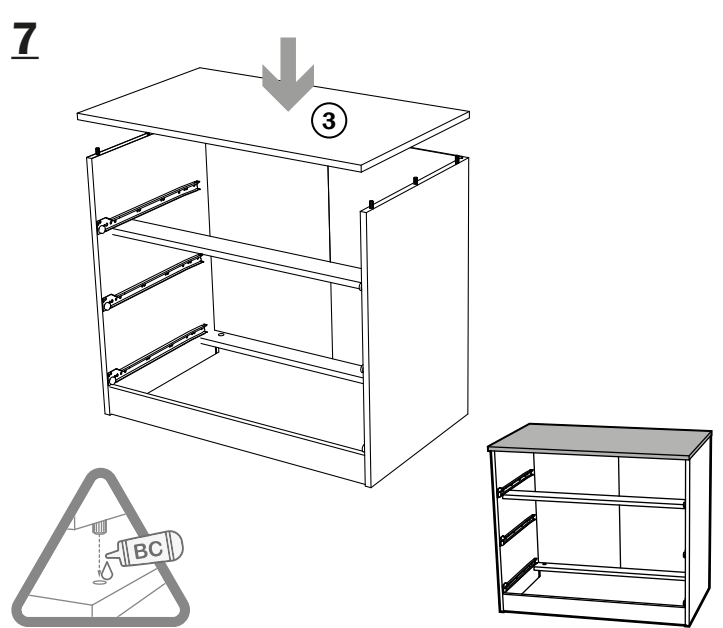

8

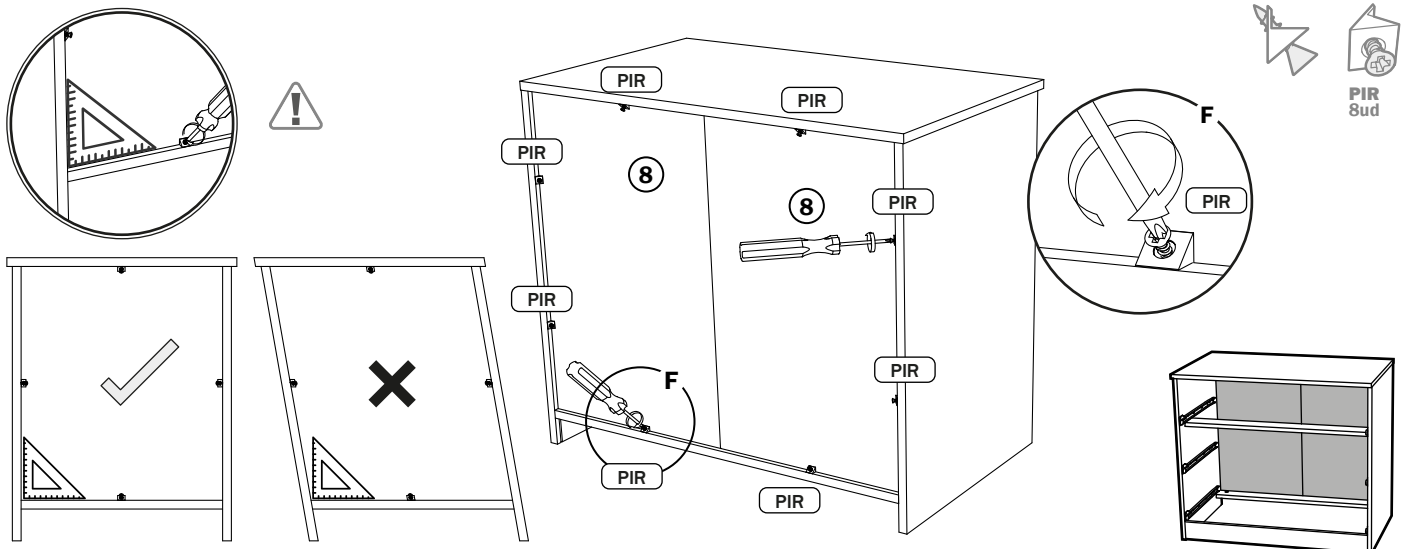

This article has a warranty according to the terms and conditions expressed by Law.
 Ce produit intègre une garantie selon les termes et conditions comprises dans la Loi.

9 x3

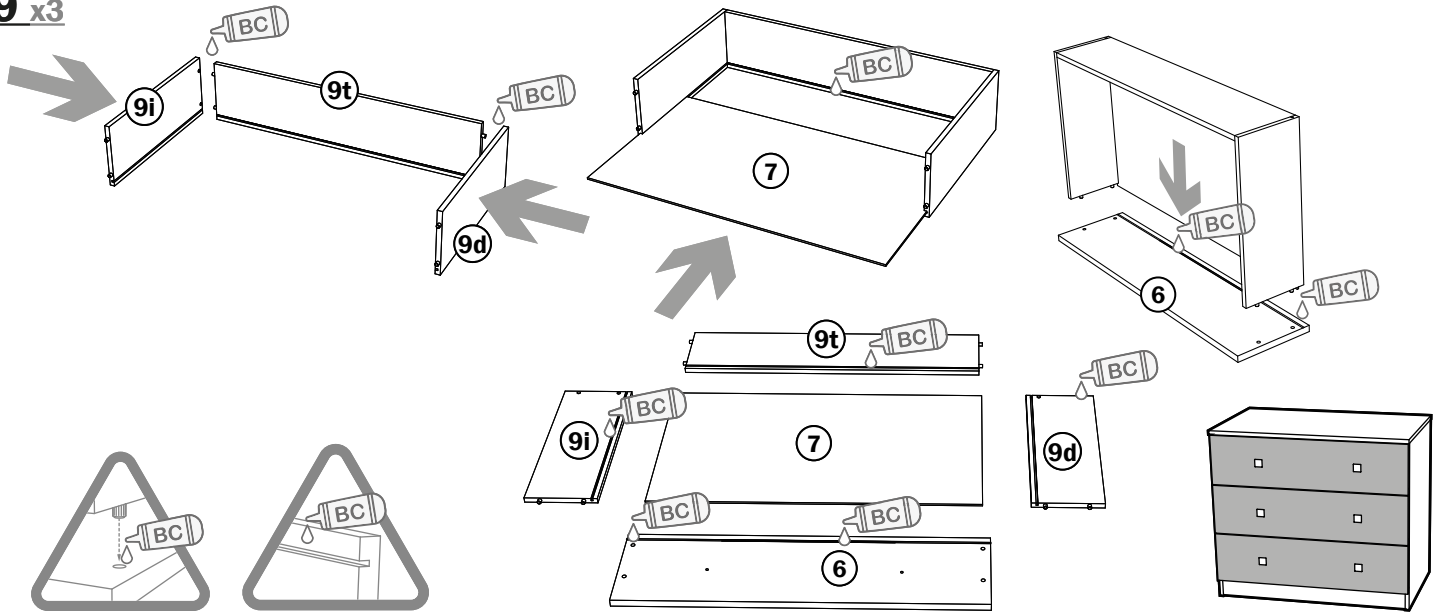

10 x3

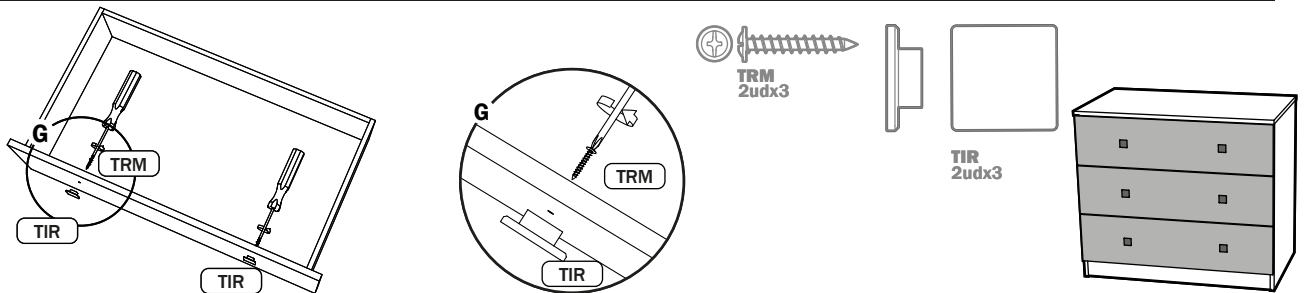

11 x3

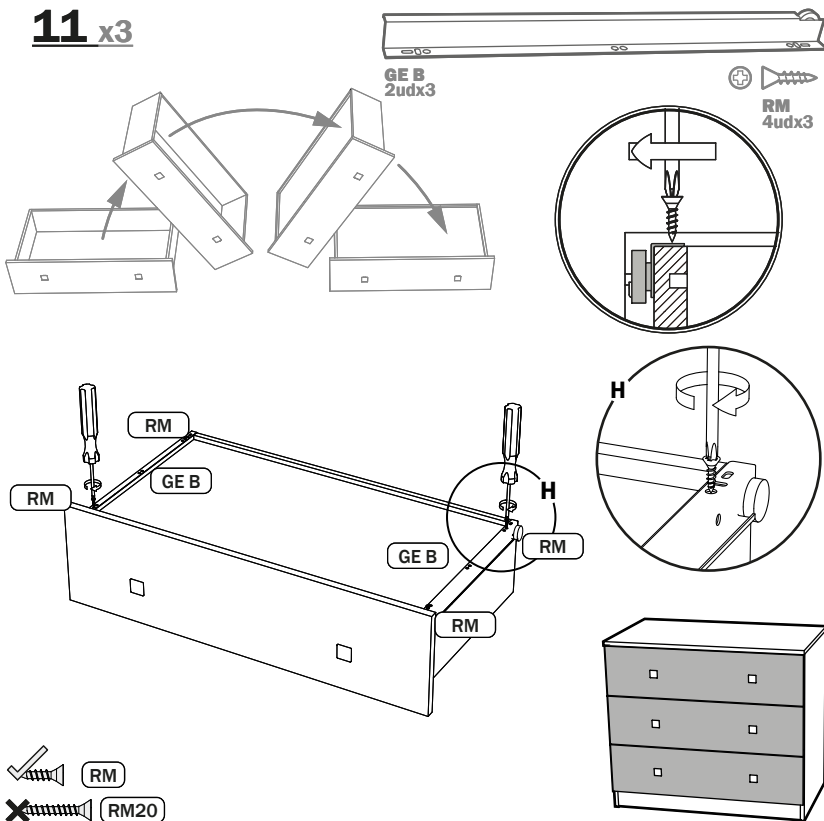

12

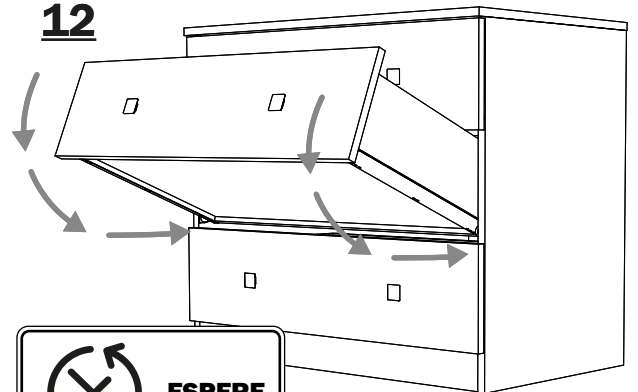

24h
ESPERE
ESPERAR
WAIT
ATTENDRE

ES. Para evitar deformaciones del cajón, colóquelo durante 24h en su posición correcta dentro del mueble sin manipularlo ni añadir peso.

PT. Para evitar a deformação da gaveta, colocá-la durante 24 horas na sua posição correcta dentro do mobiliário sem a manusear ou adicionar peso.

EN. To avoid deformation of the drawer, place it for 24 hours in its correct position inside the cabinet without handling it or adding weight.

FR. Pour éviter la déformation du tiroir, placez-le pendant 24 heures dans sa position correcte à l'intérieur du meuble sans le manipuler ni lui ajouter de poids.



PARA MÁS INFORMACIÓN
ESCANEAR EL CÓDIGO BIDI
PARA MAIS INFORMAÇÕES,
VOCÊ PODE DIGITALIZAR O
CÓDIGO BIDI
FOR MORE INFORMATION
YOU CAN SCAN THE BIDI
POUR PLUS D'INFORMA-
TION VOUS SCANNER LE
CODE BIDI

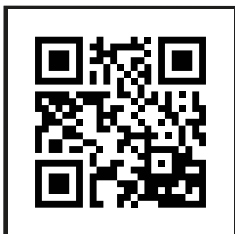

ES Conserve ésta etiqueta para cualquier tipo de reclamación
PT Guarde este rótulo para qualquer tipo de reclamação
EN Keep this label for any requests you may have.
FR Conservez cette étiquette pour tout type de réclamation

