

EN Assembly instructions
DE Montageanleitung

Metzler GmbH
Täleswiesenstraße 9
72770 Reutlingen

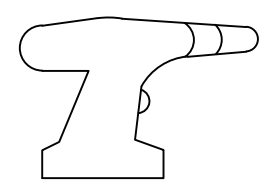
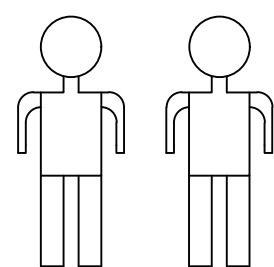
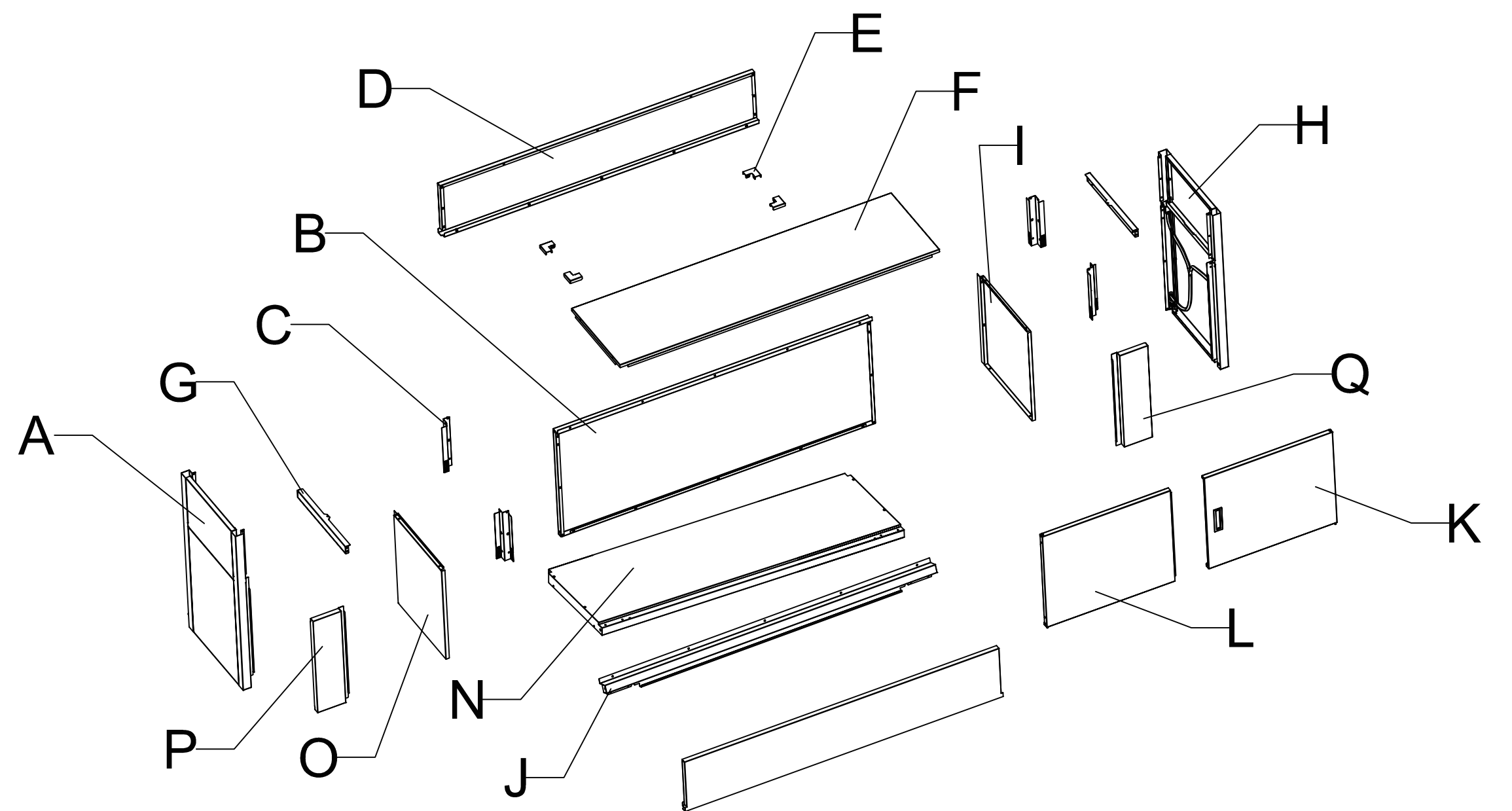
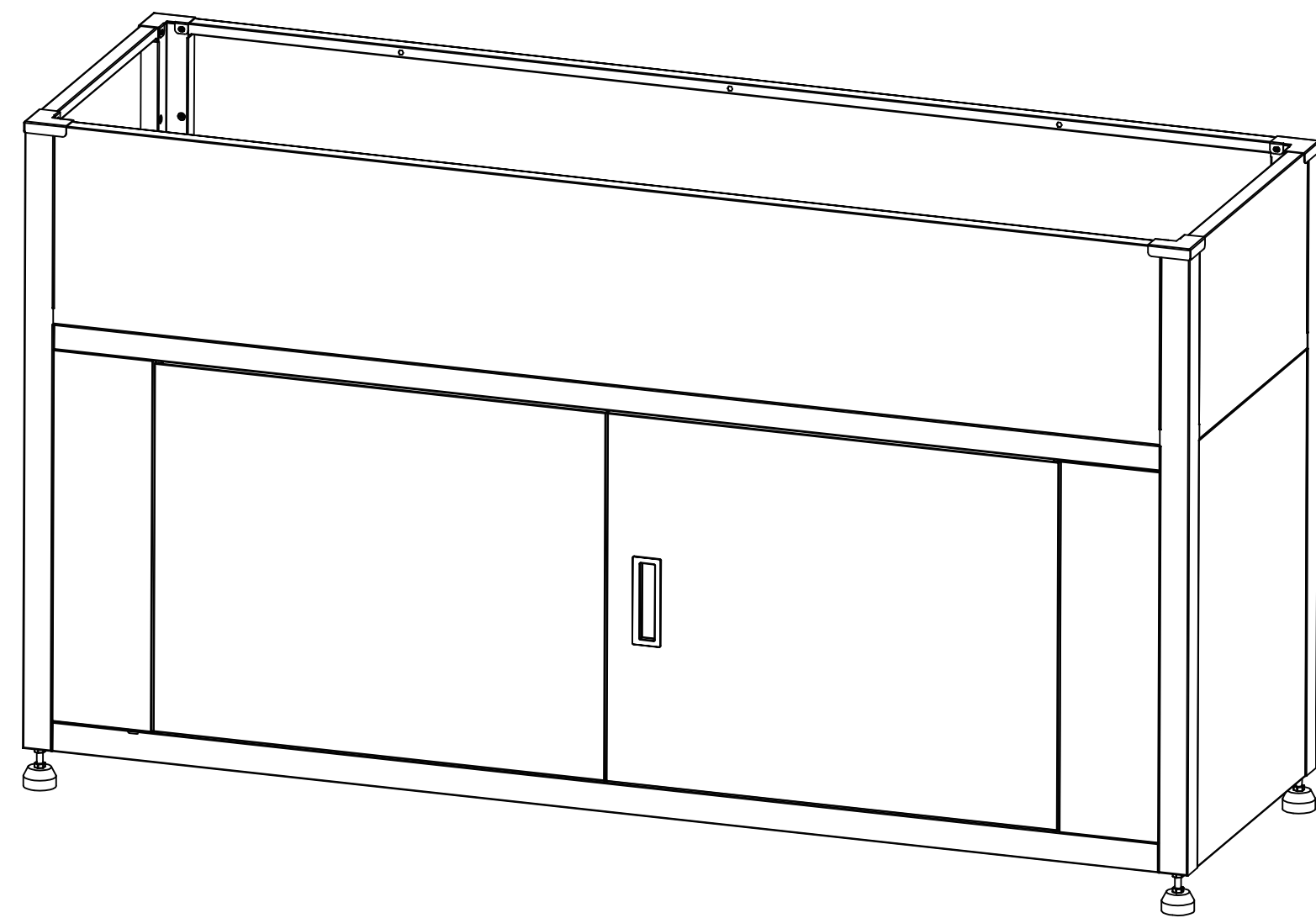
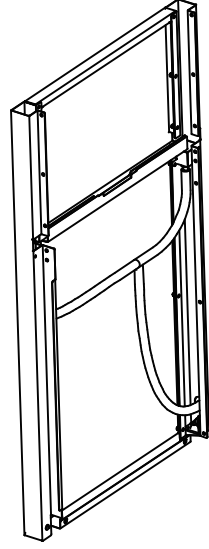
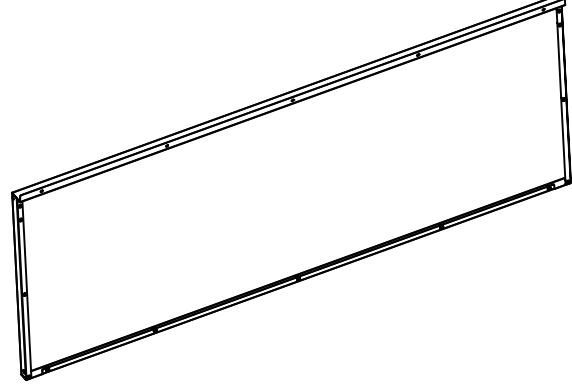
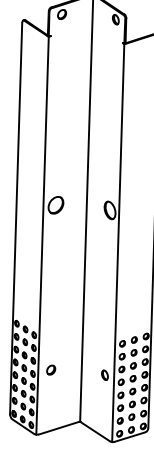
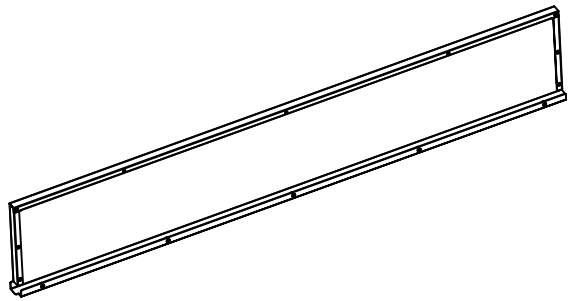
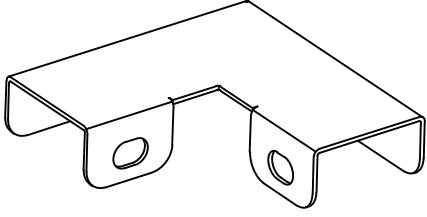
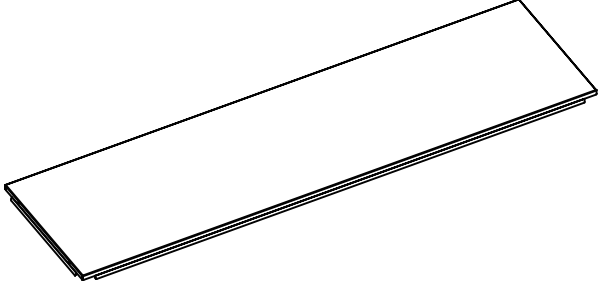
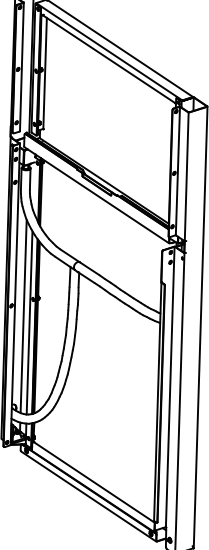
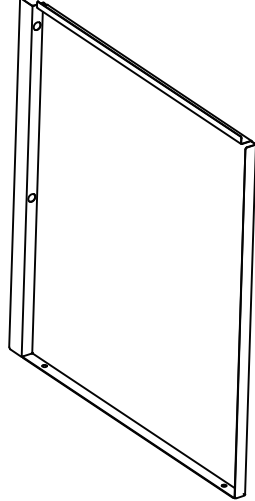
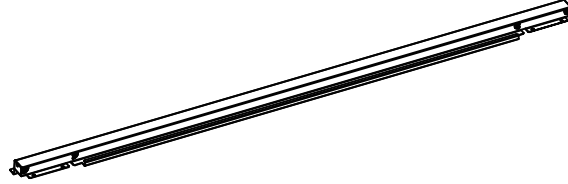
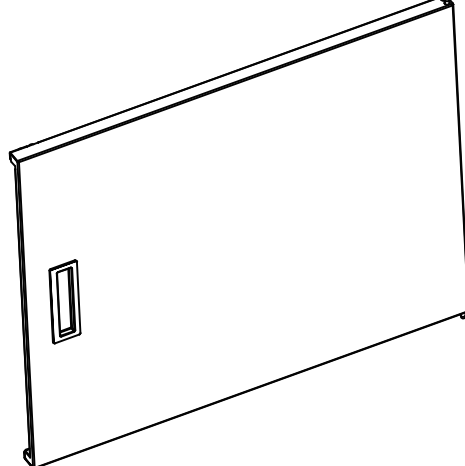
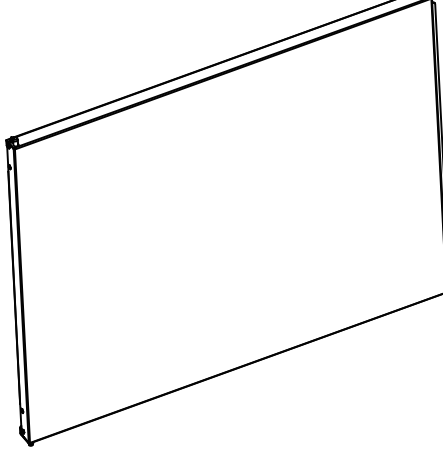
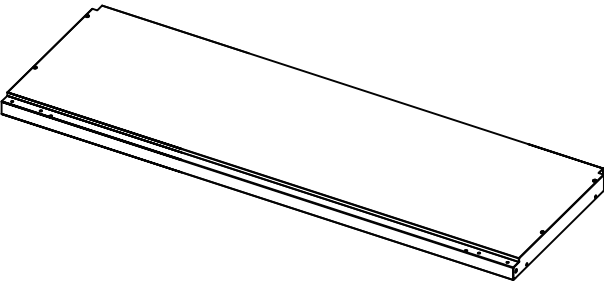
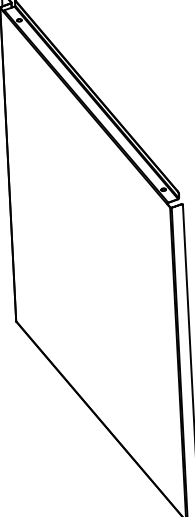
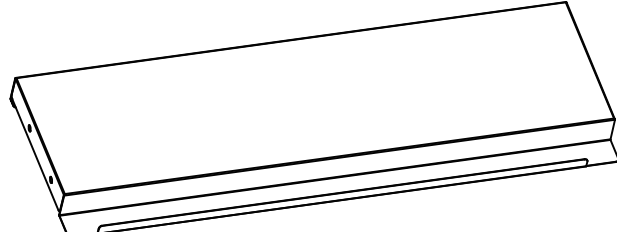
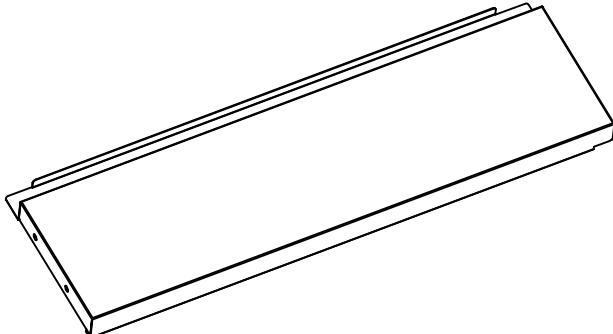
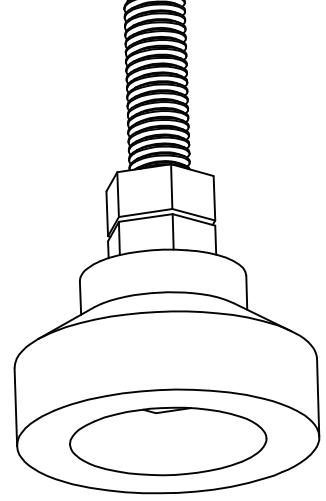
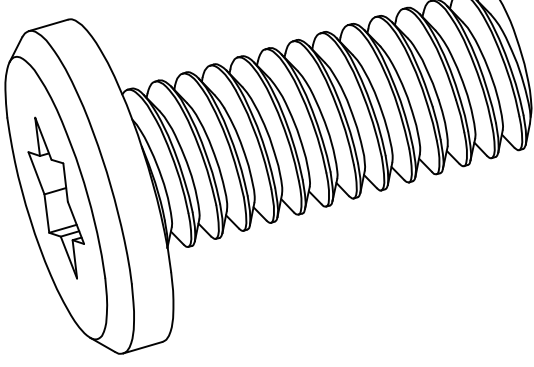
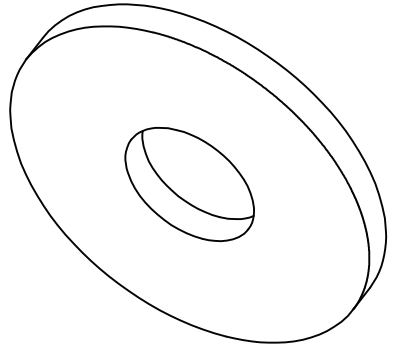
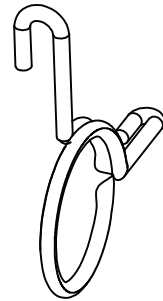
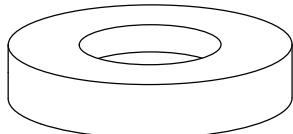
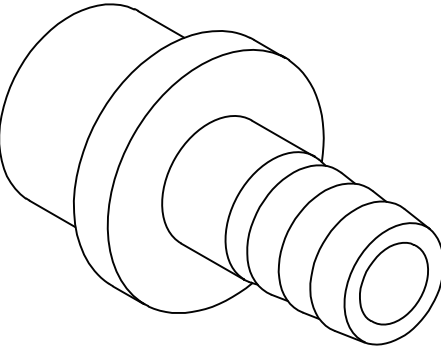
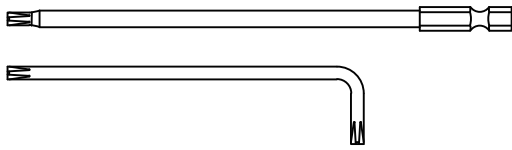
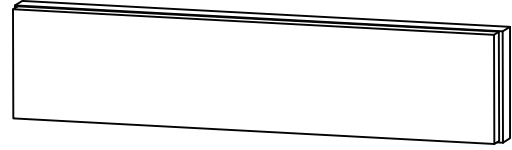

2H

<p>Ax1 ②</p> 	<p>Bx1 ①</p> 	<p>Cx4 ②</p> 	<p>Dx2 ①</p> 	<p>Ex4 ②</p> 	<p>Fx1 ②</p> 
<p>Hx1 ②</p> 	<p>Ix1 ②</p> 	<p>Jx1 ②</p> 	<p>Kx1 ①</p> 	<p>Lx1 ①</p> 	<p>Nx1 ①</p> 
<p>Ox1 ②</p> 	<p>Px1 ②</p> 	<p>Qx1 ②</p> 	<p>Rx4 ②</p> 	<p>Sx59 ②</p>  <p>M4x10mm</p>	<p>Tx55 ②</p>  <p>Ø4xØ12x1mm</p>
<p>Ux2 ②</p> 	<p>Vx2 ②</p>  <p>Ø6.2xØ9x3mm</p>	<p>Wx2 ②</p> 	<p>Xx1 ②</p> 	<p>Yx2 ②</p>  <p>45x10mm</p>	

STEP1

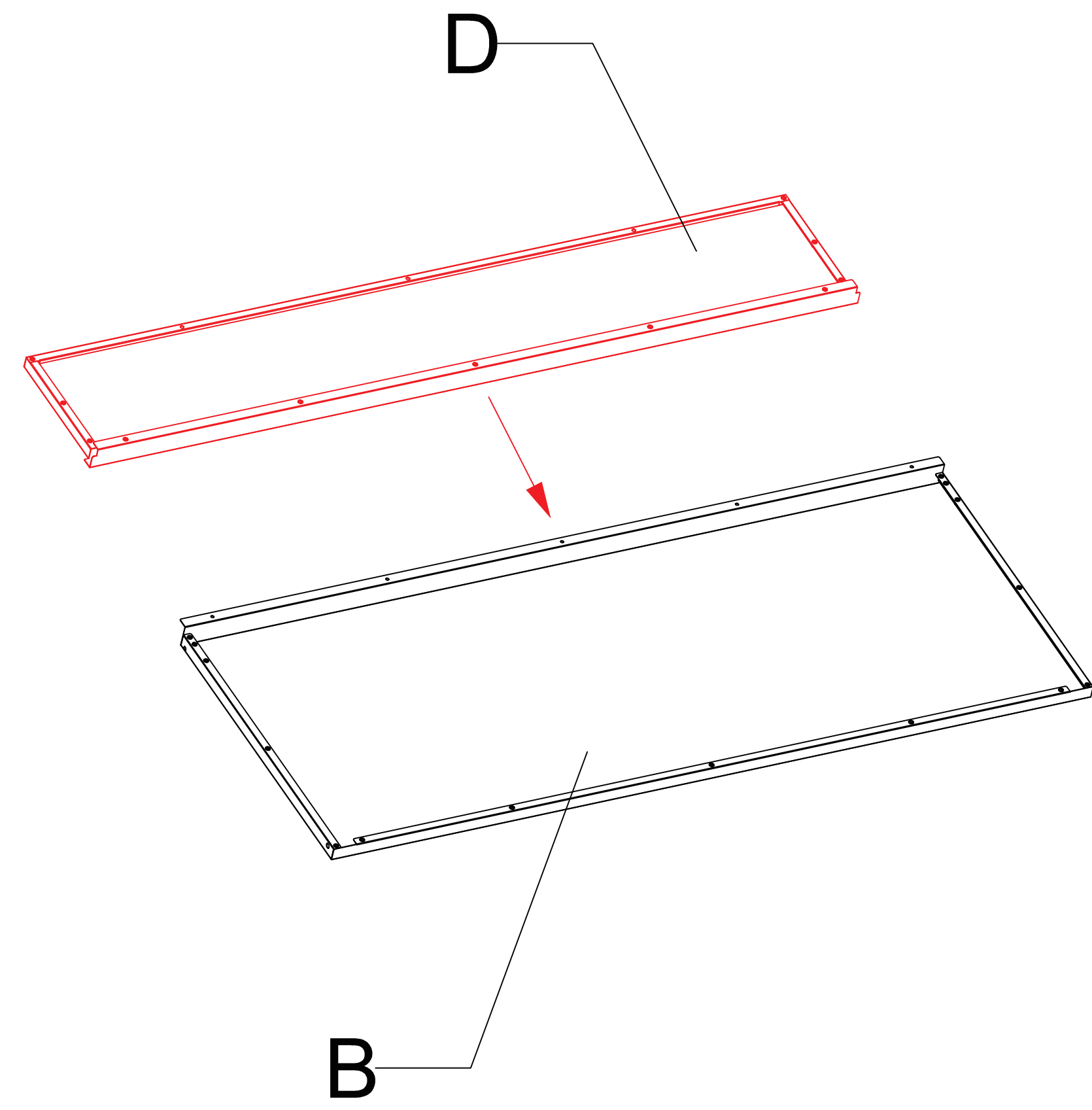
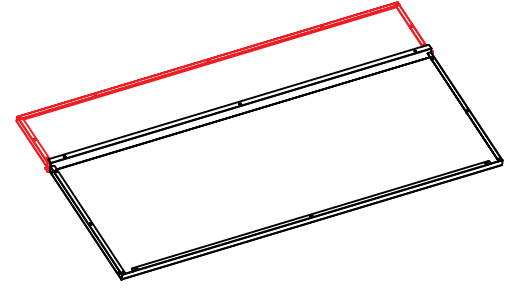

STEP1-1

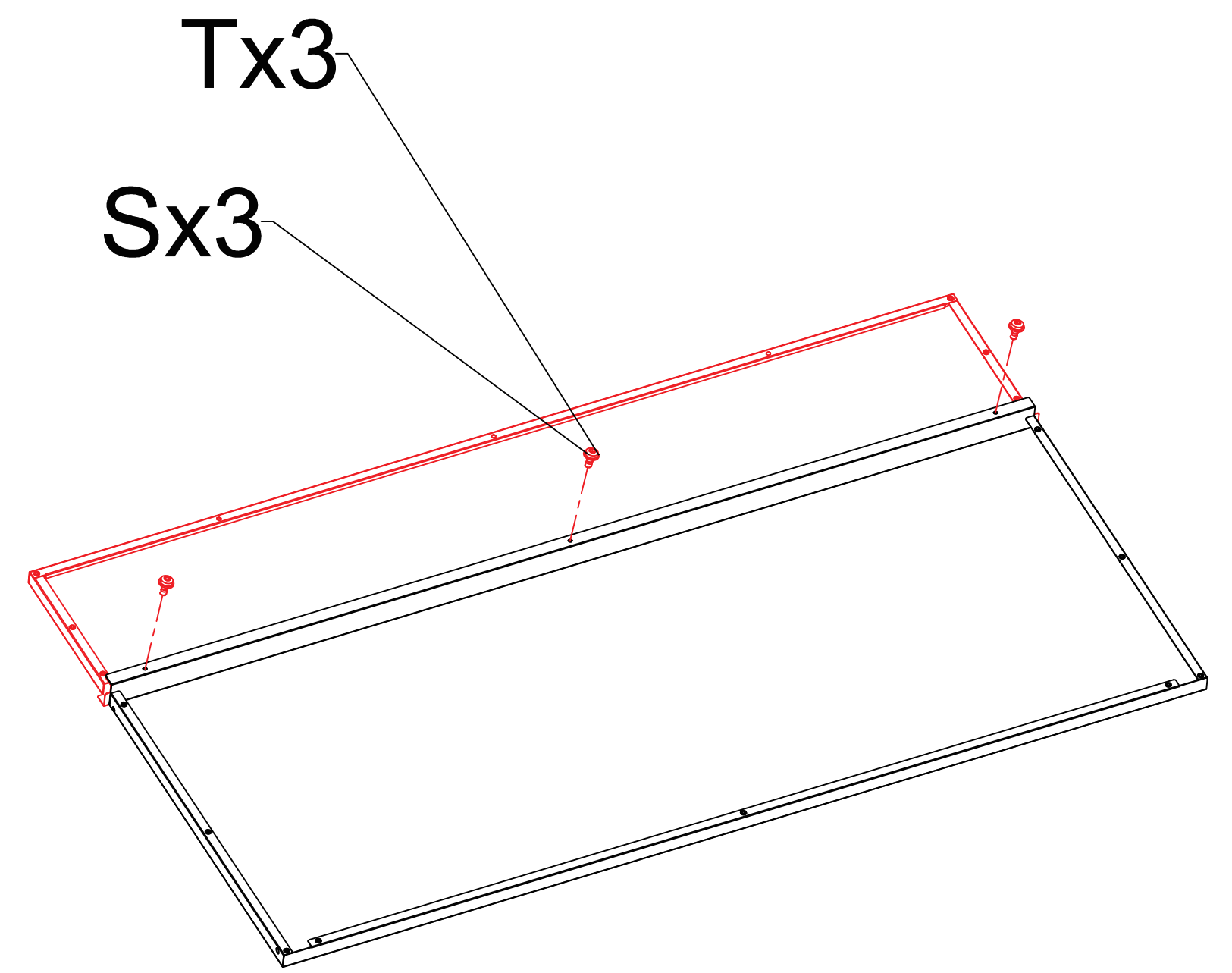

STEP1-2

STEP2

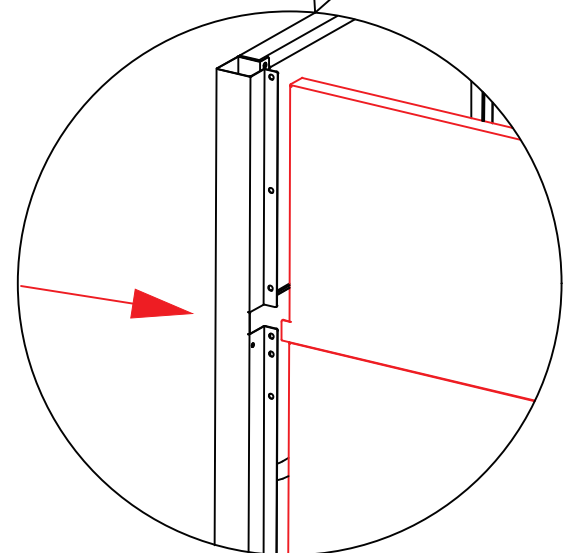
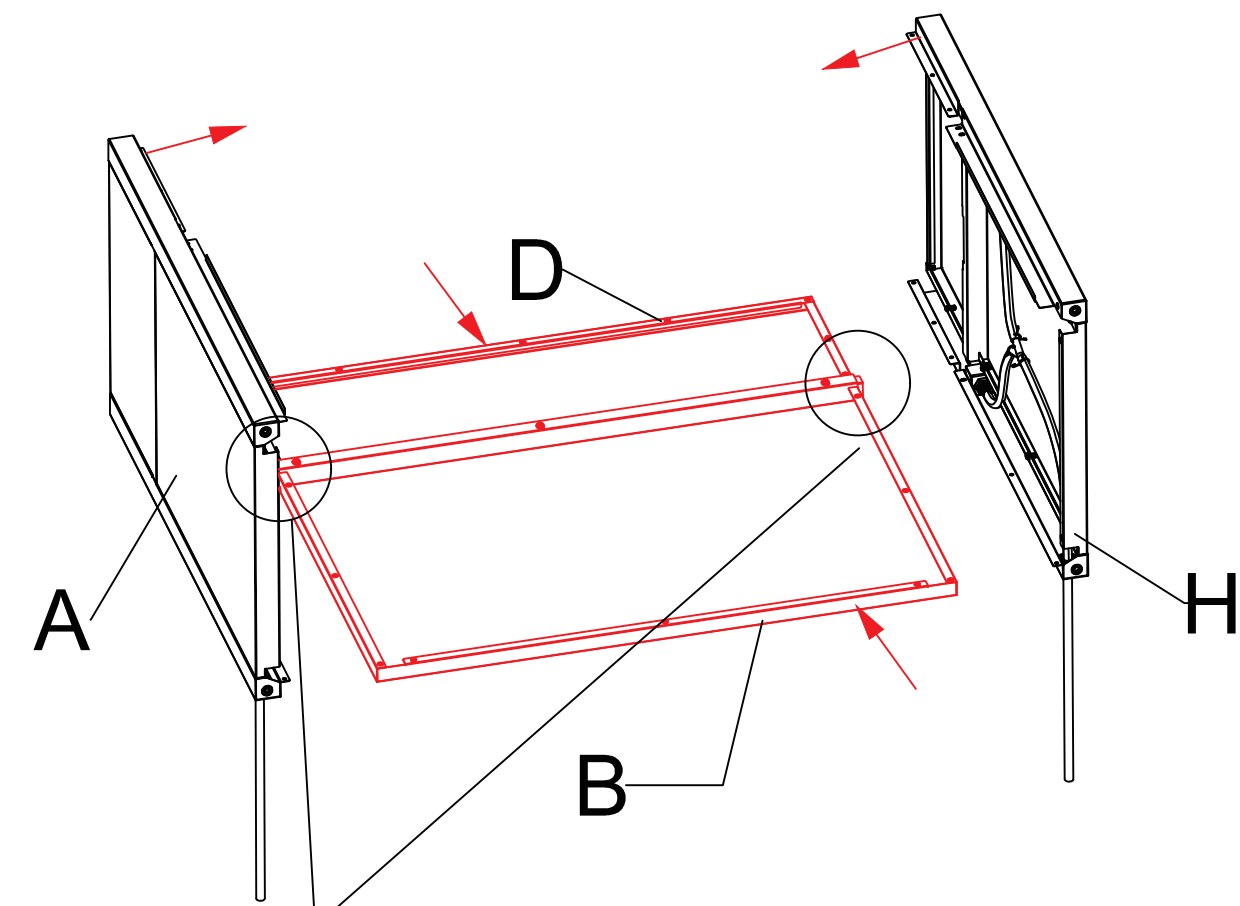
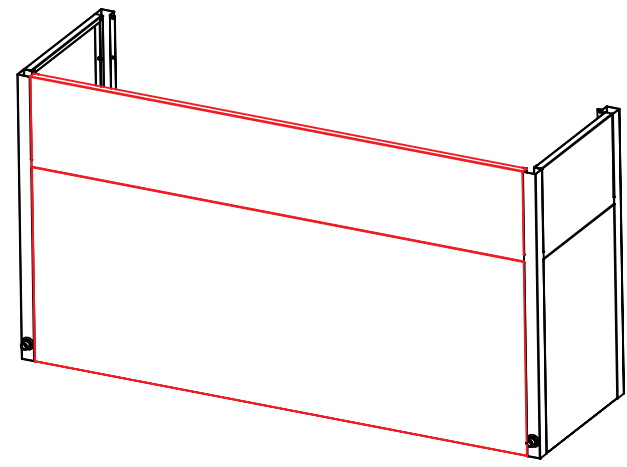

STEP2-1

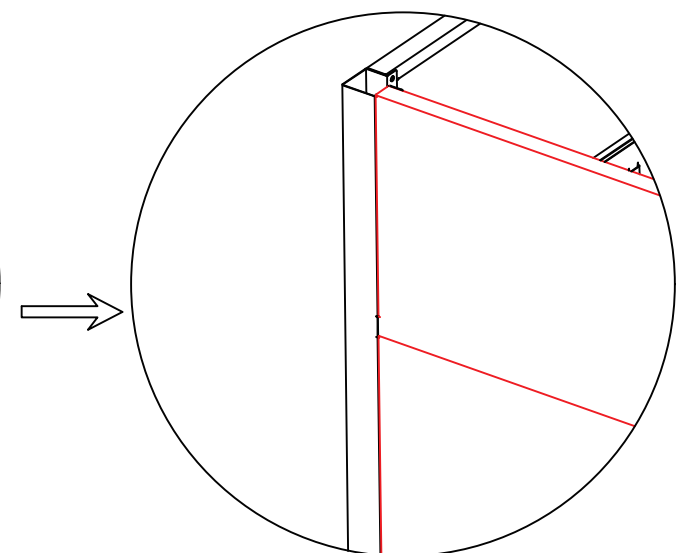

STEP2-2

STEP2-3

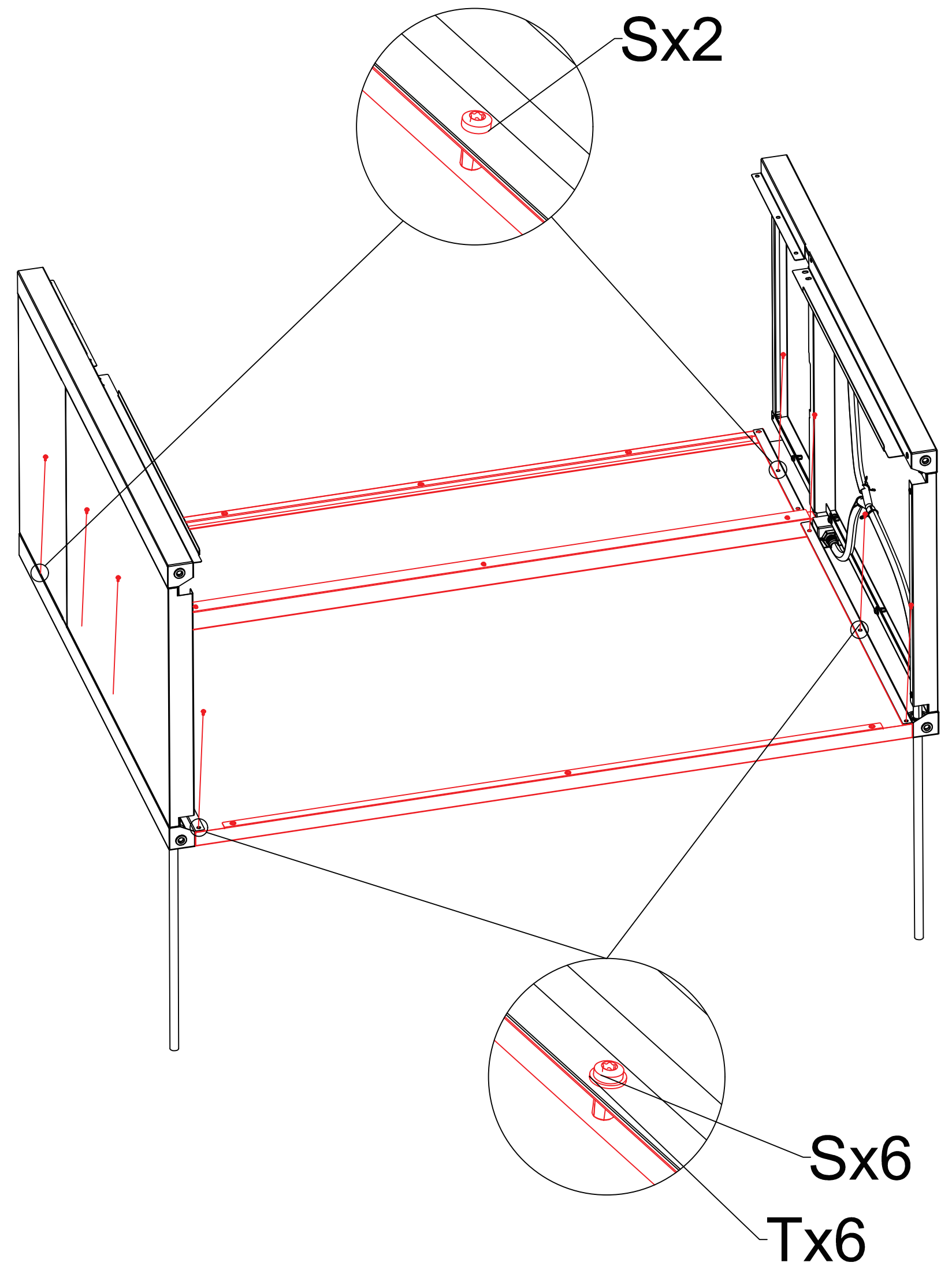

STEP3

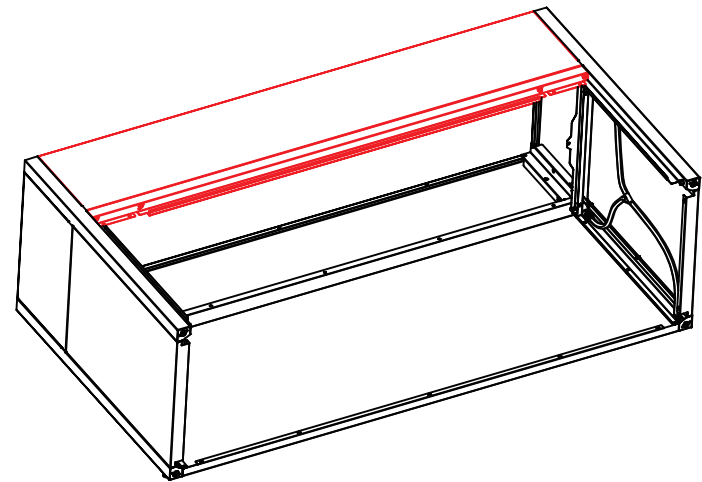

STEP3-1

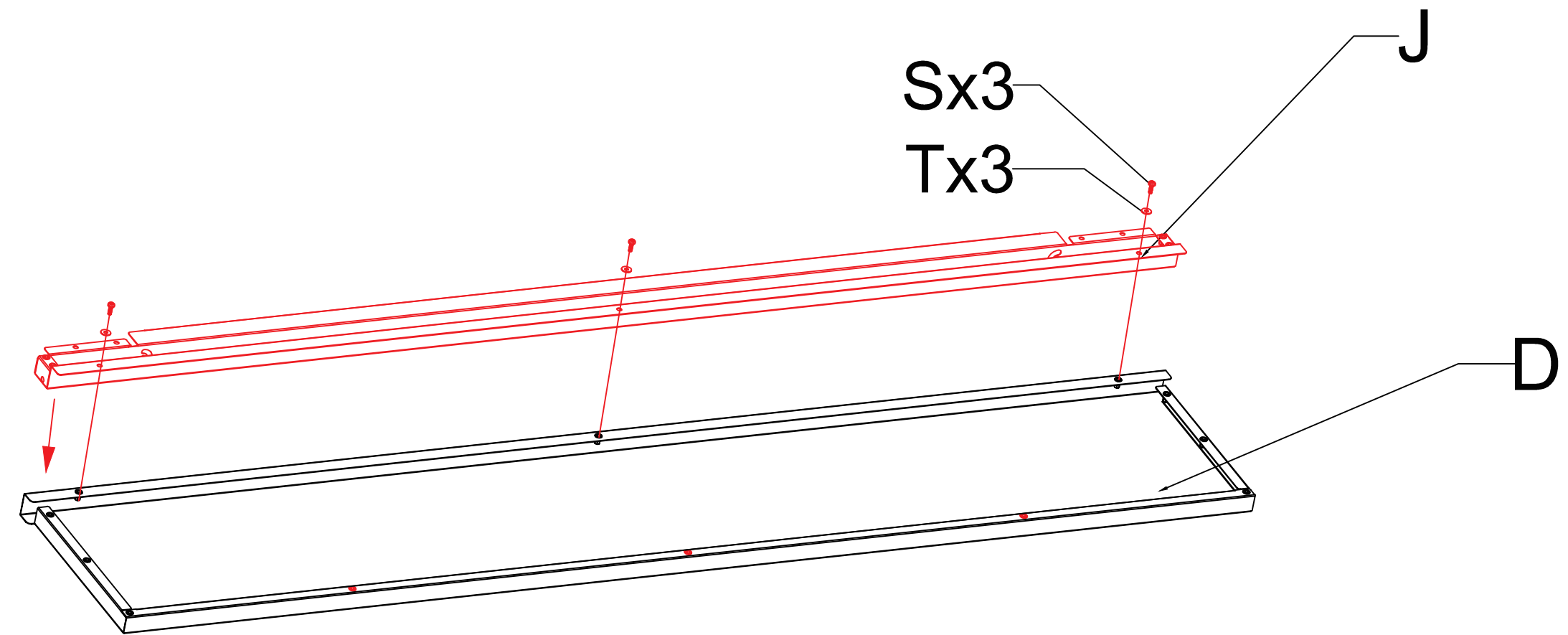

STEP3-2

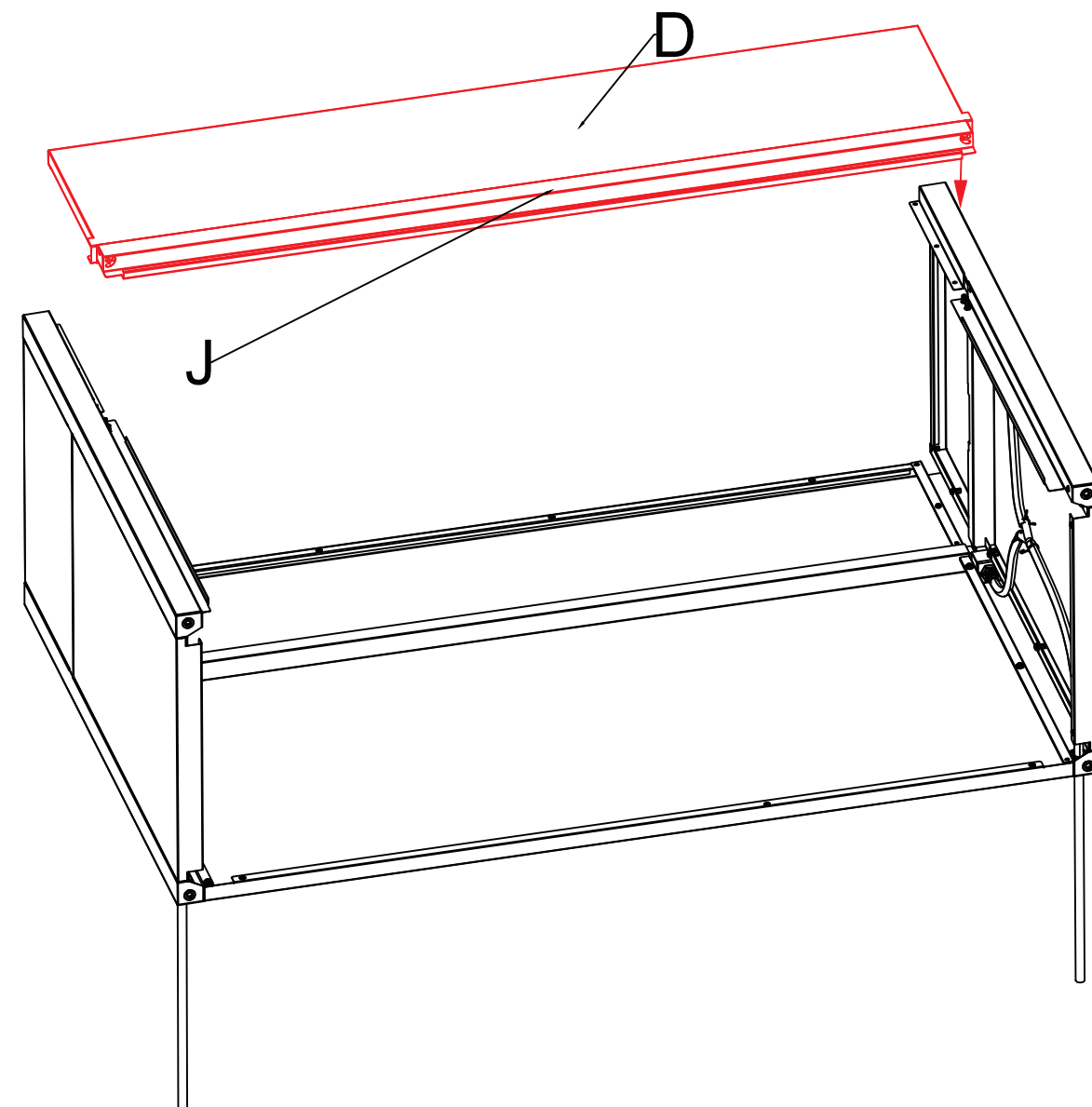

STEP3-3

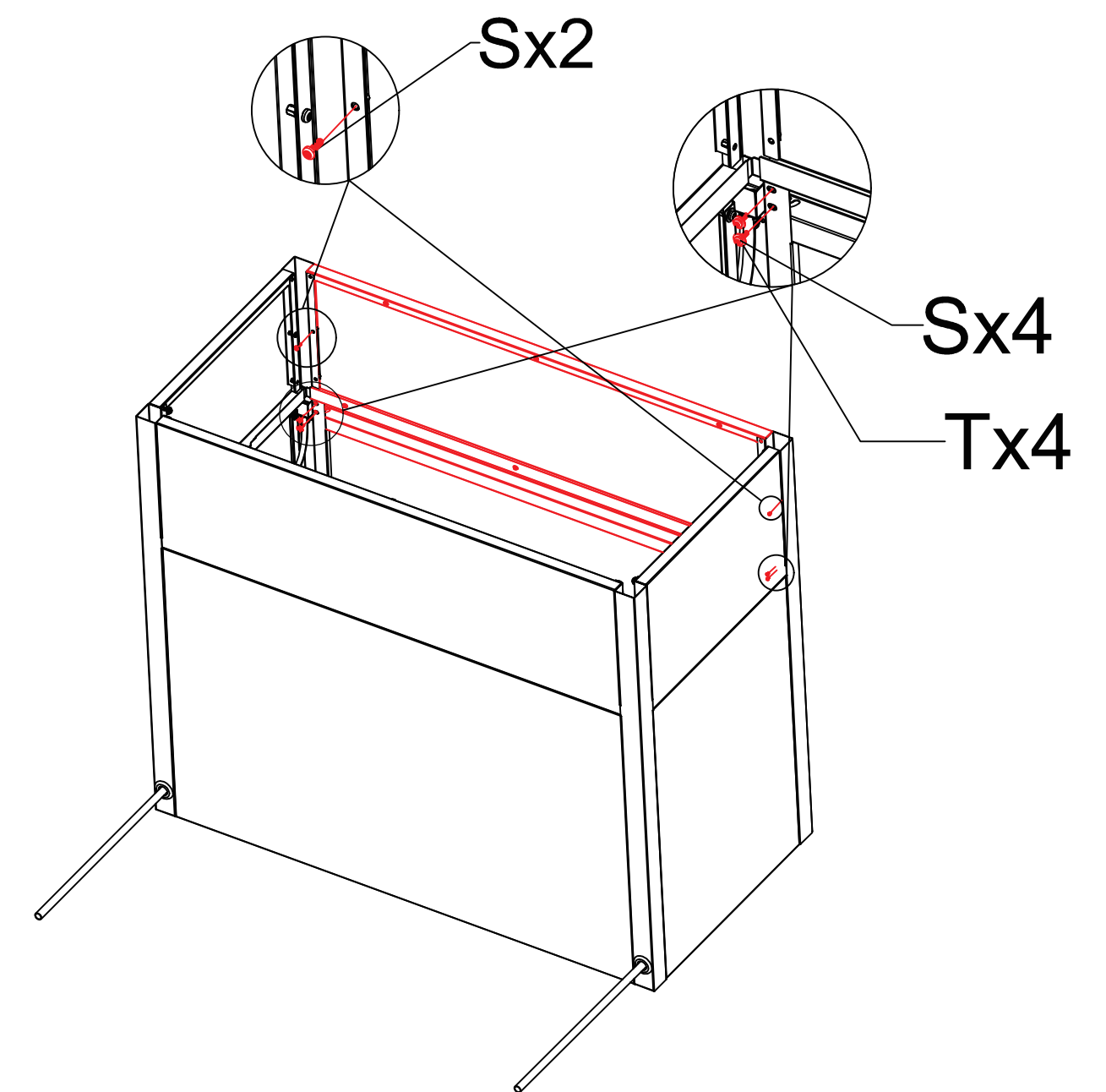

STEP4

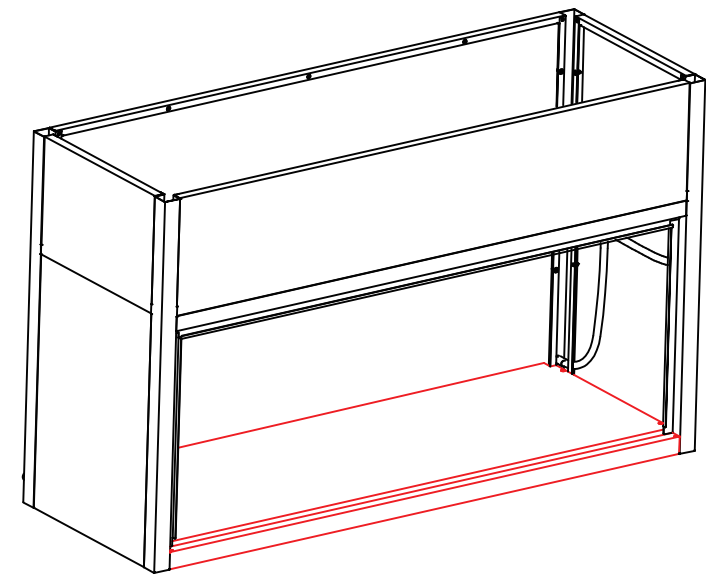

STEP4-1

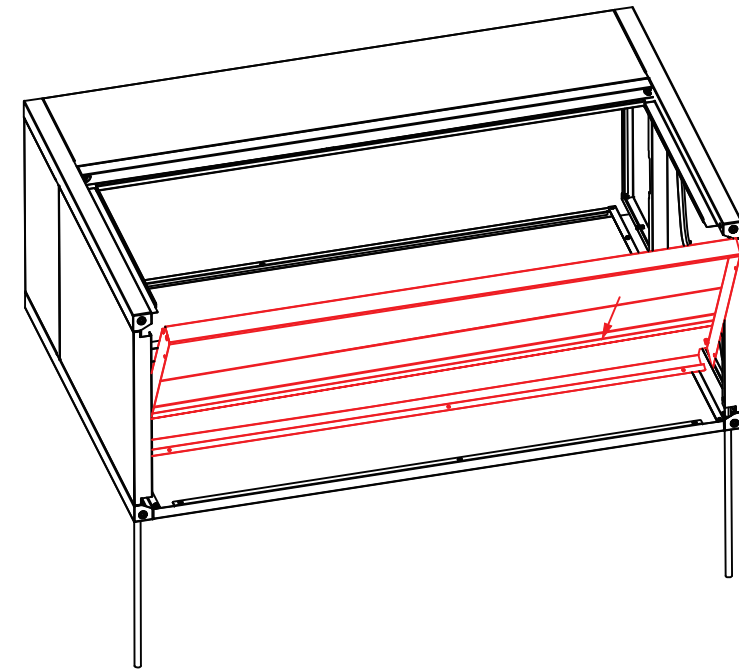

STEP4-2

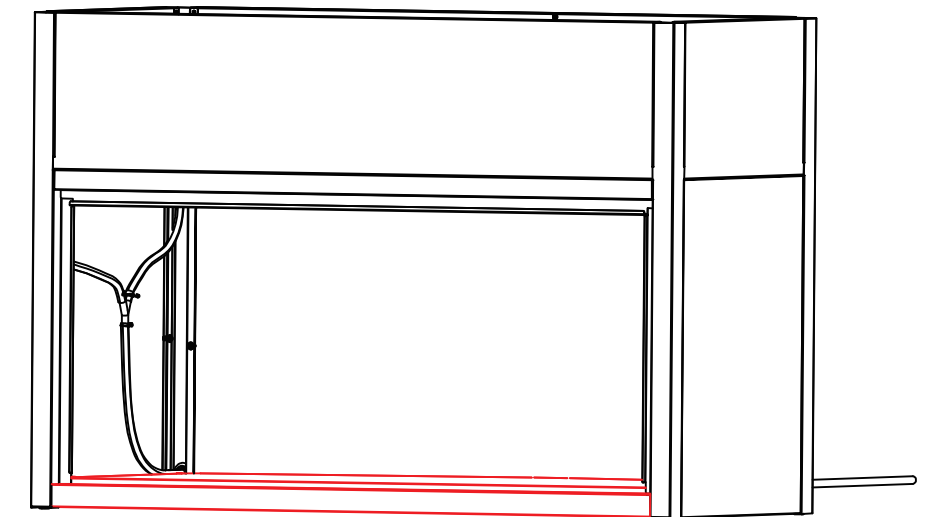

STEP4-3

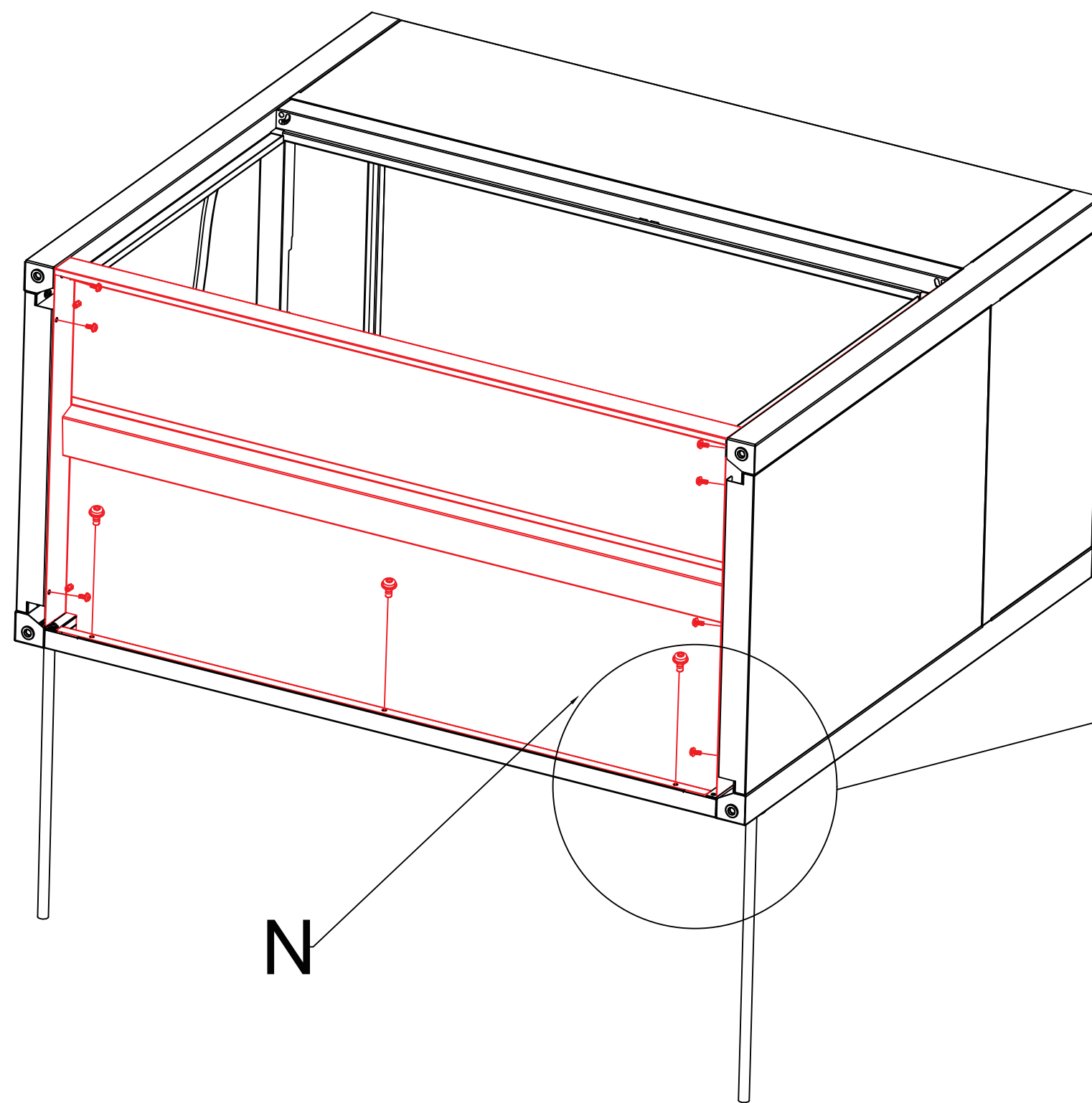

N

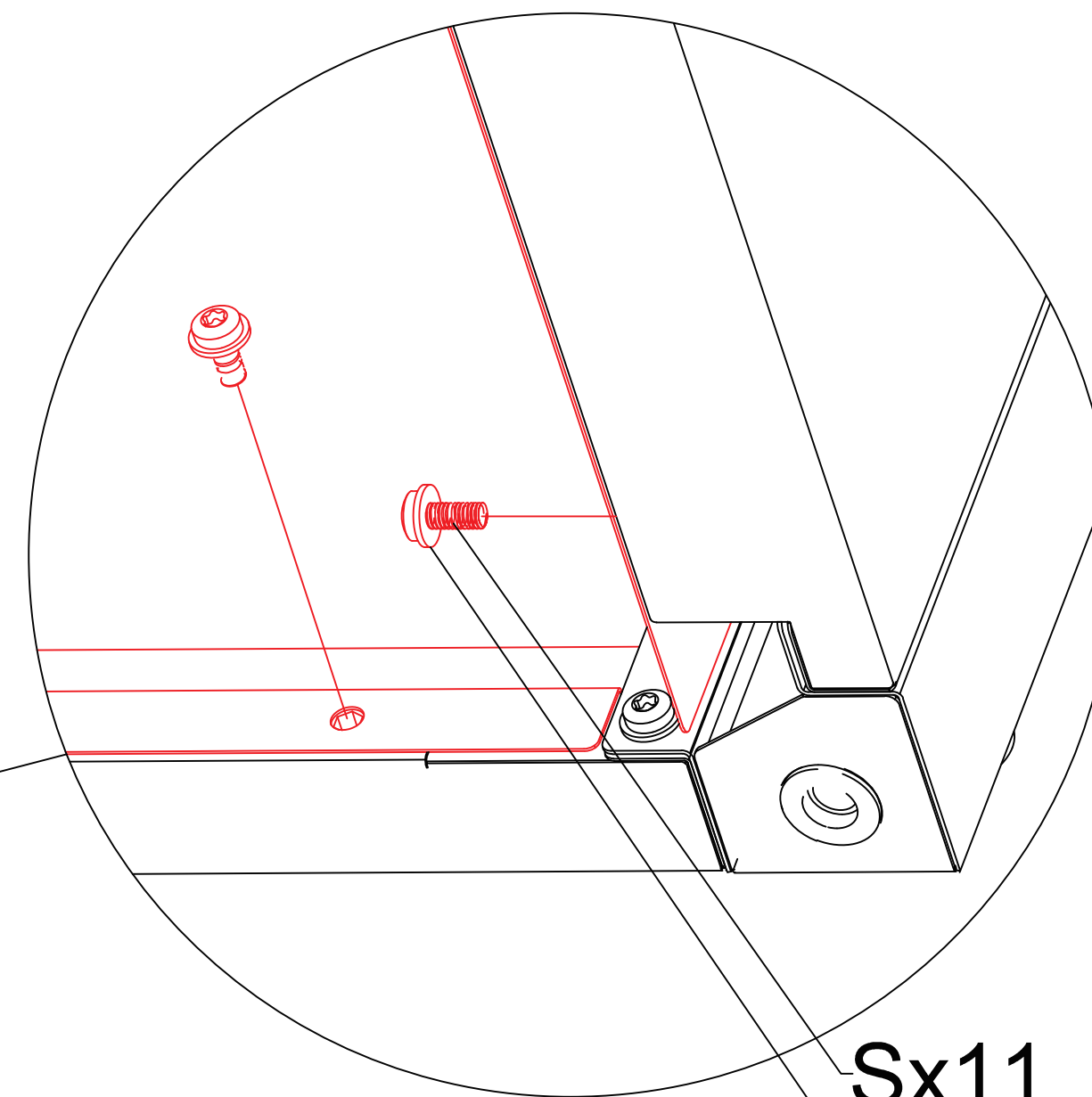

Sx11
Tx11

STEP 5

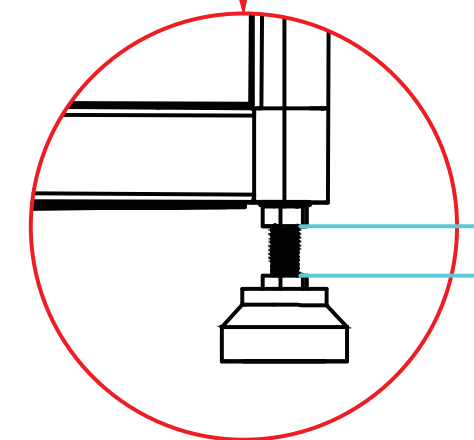
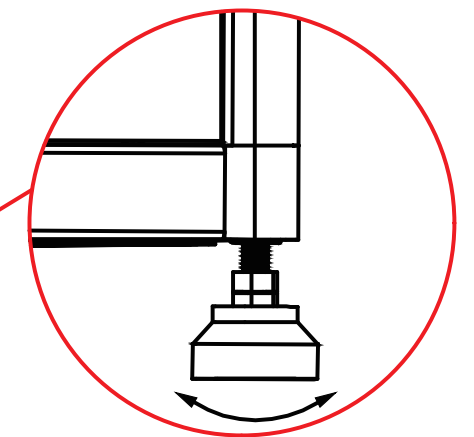
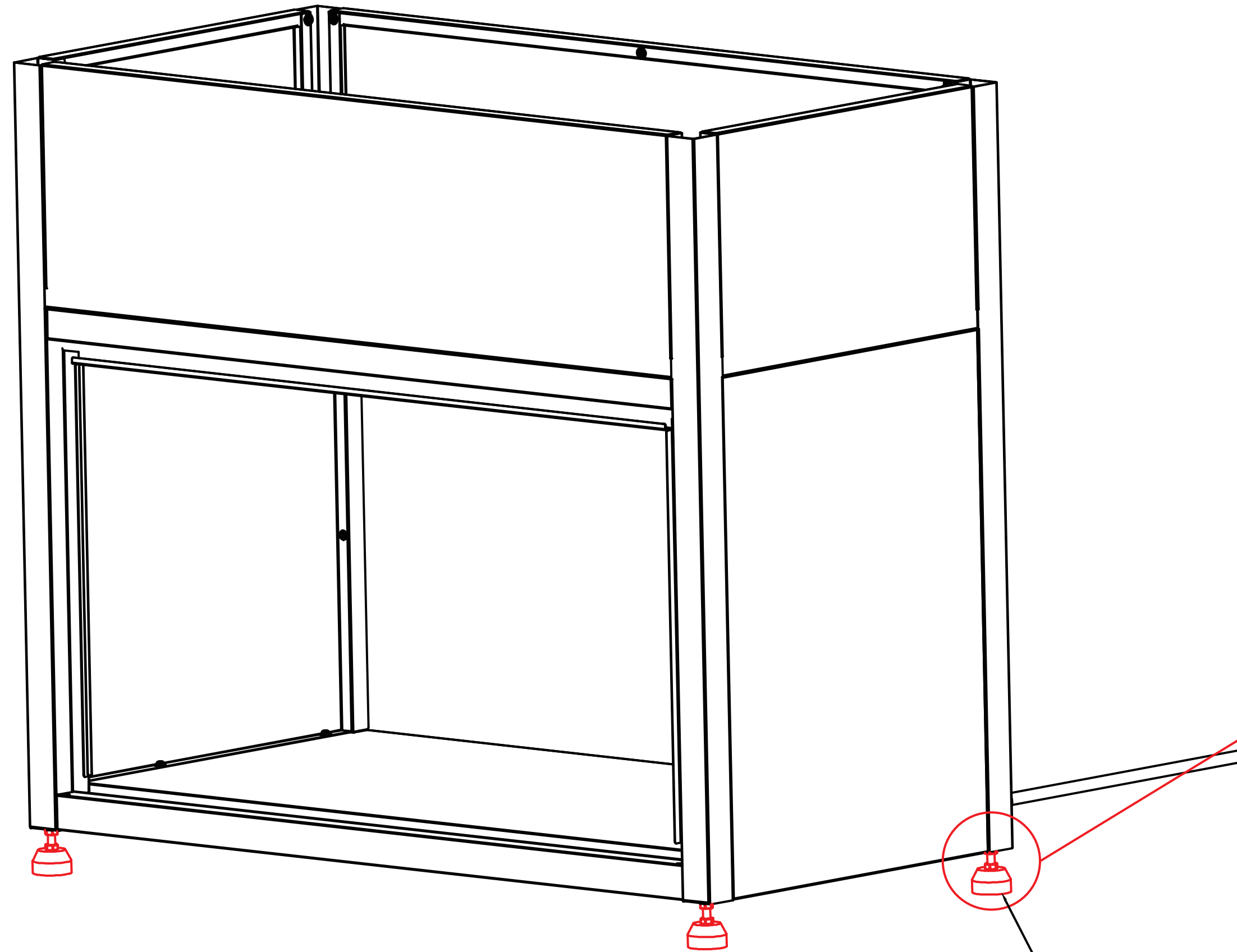
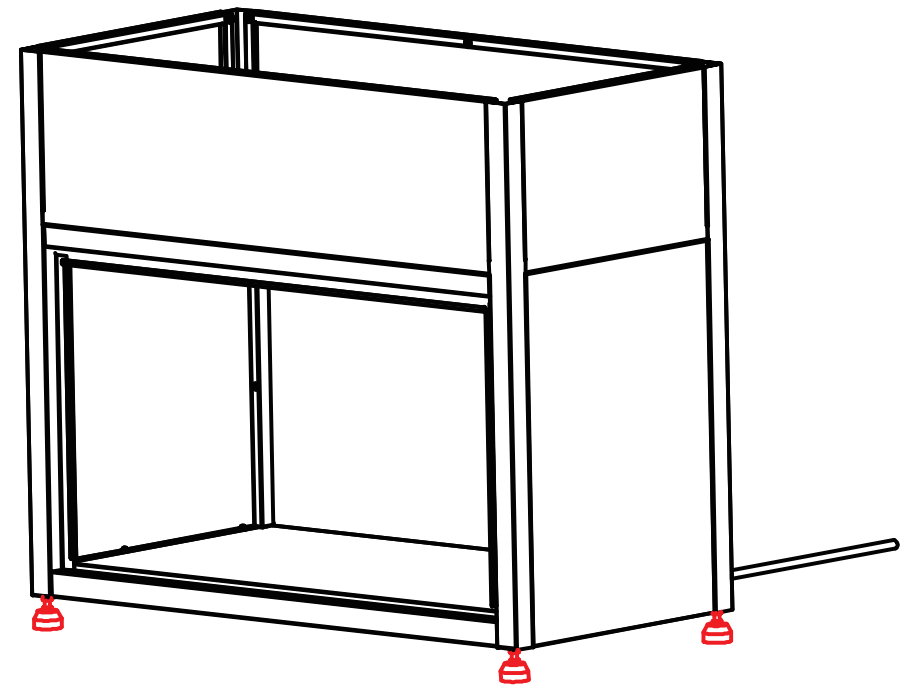

MAX15mm

Rx4

STEP 6

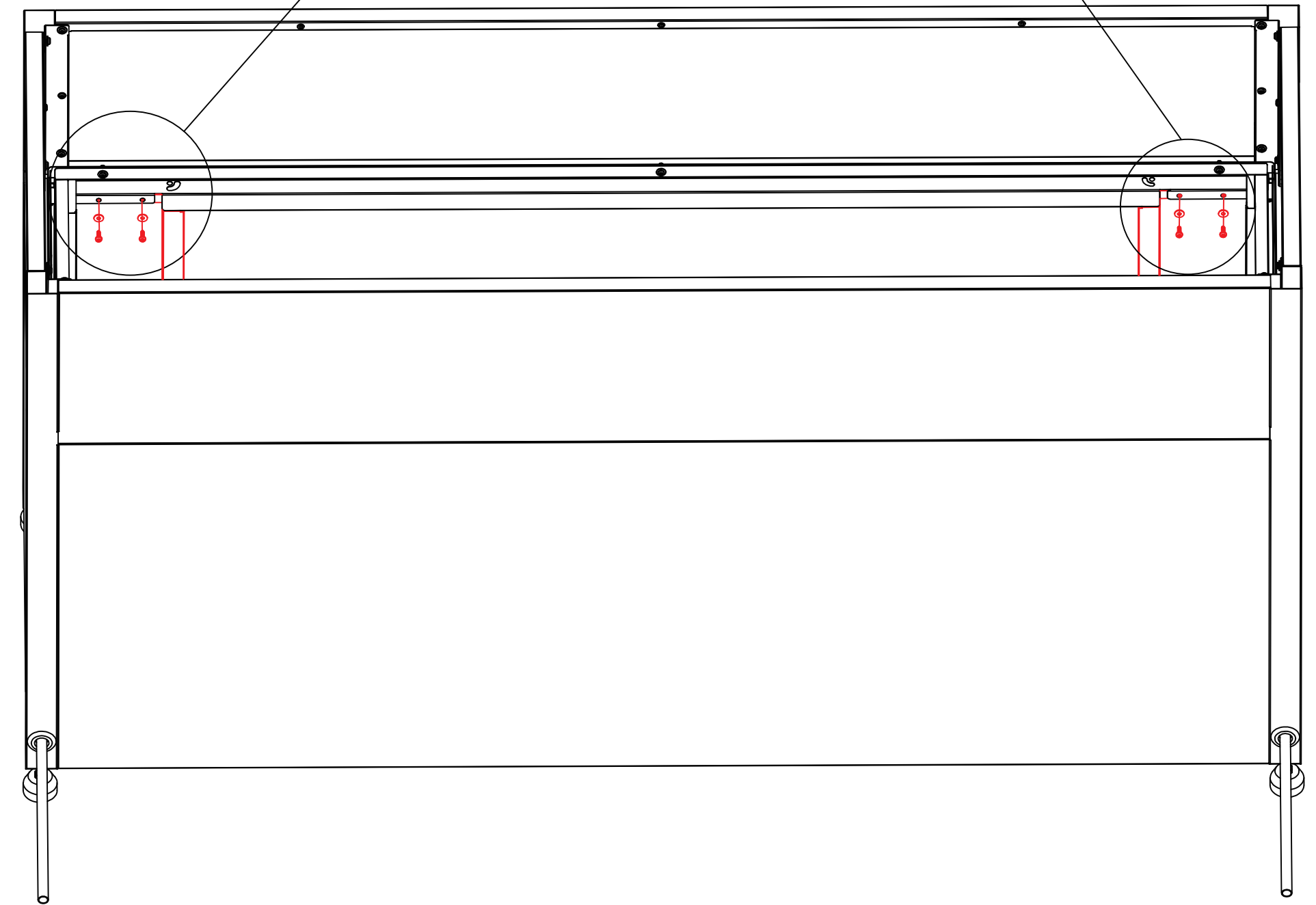
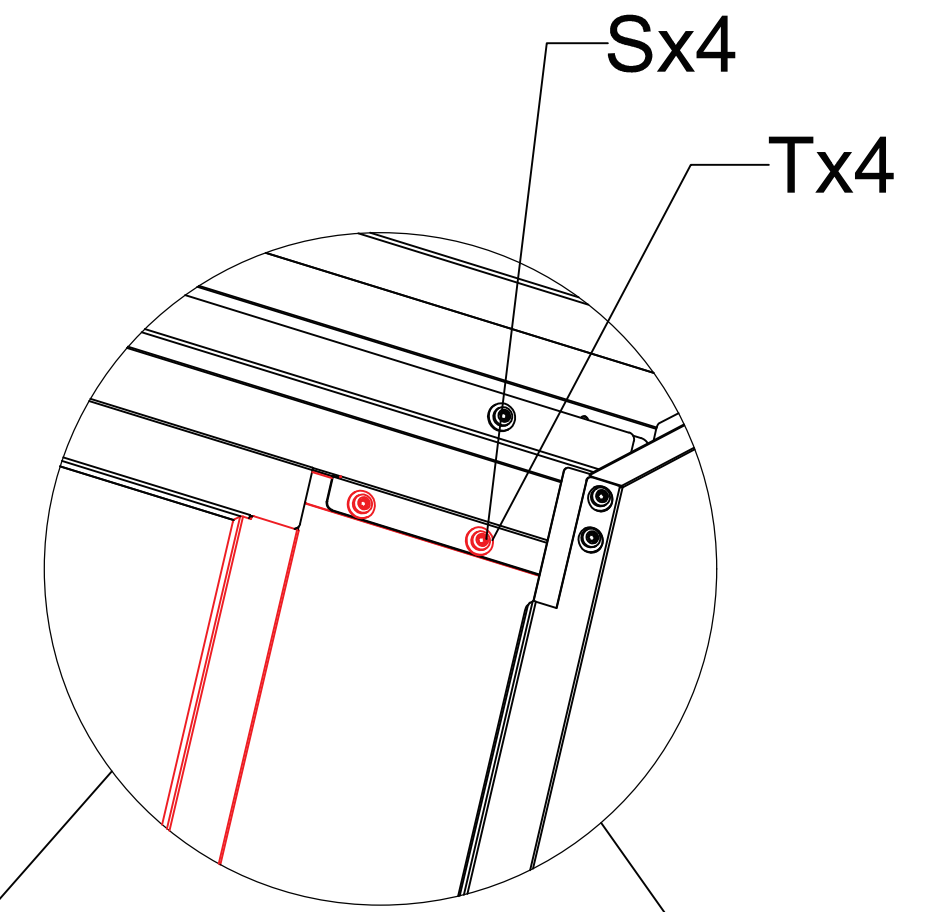
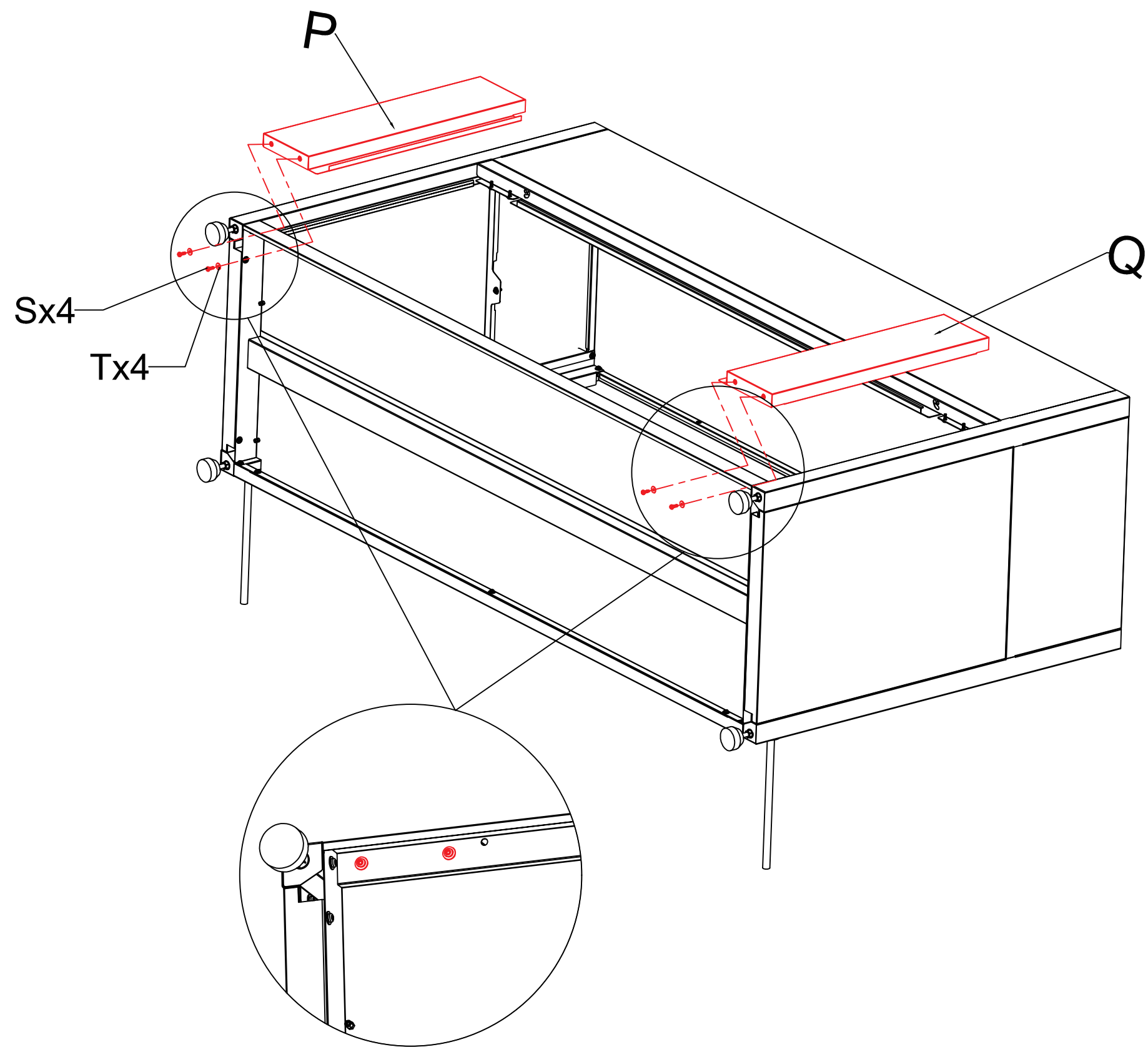
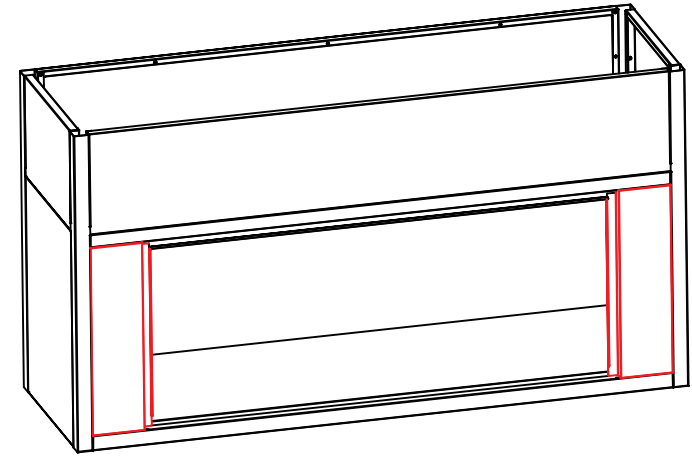

STEP7

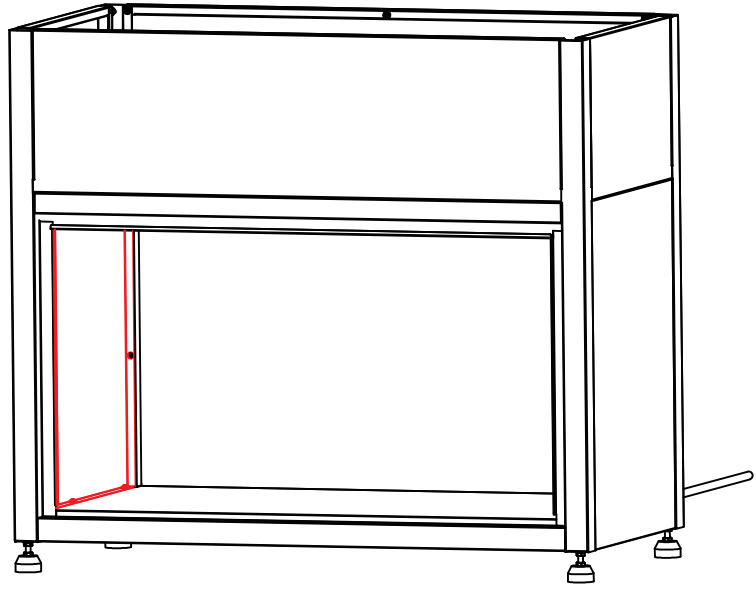

STEP7-1

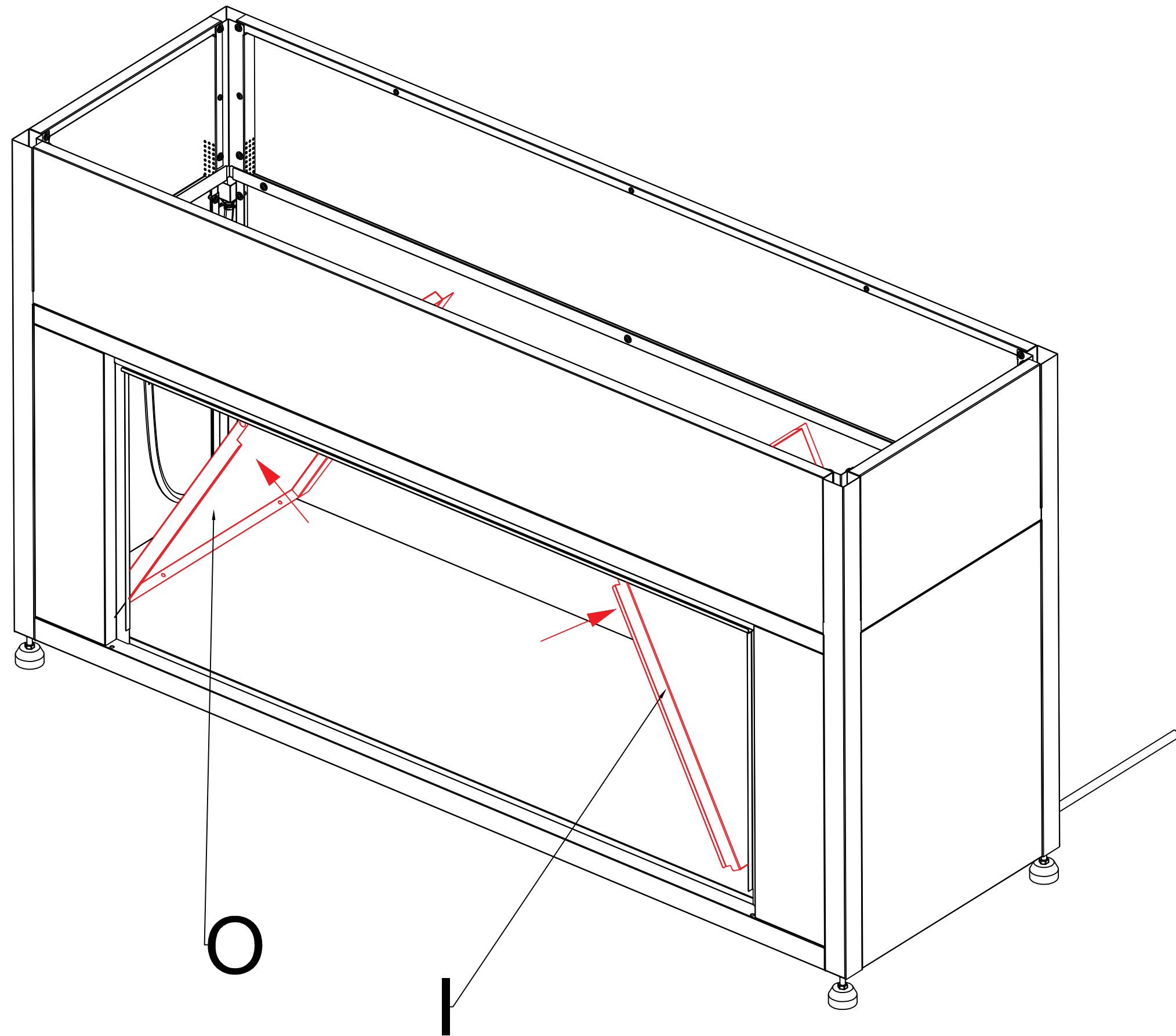

STEP7-2

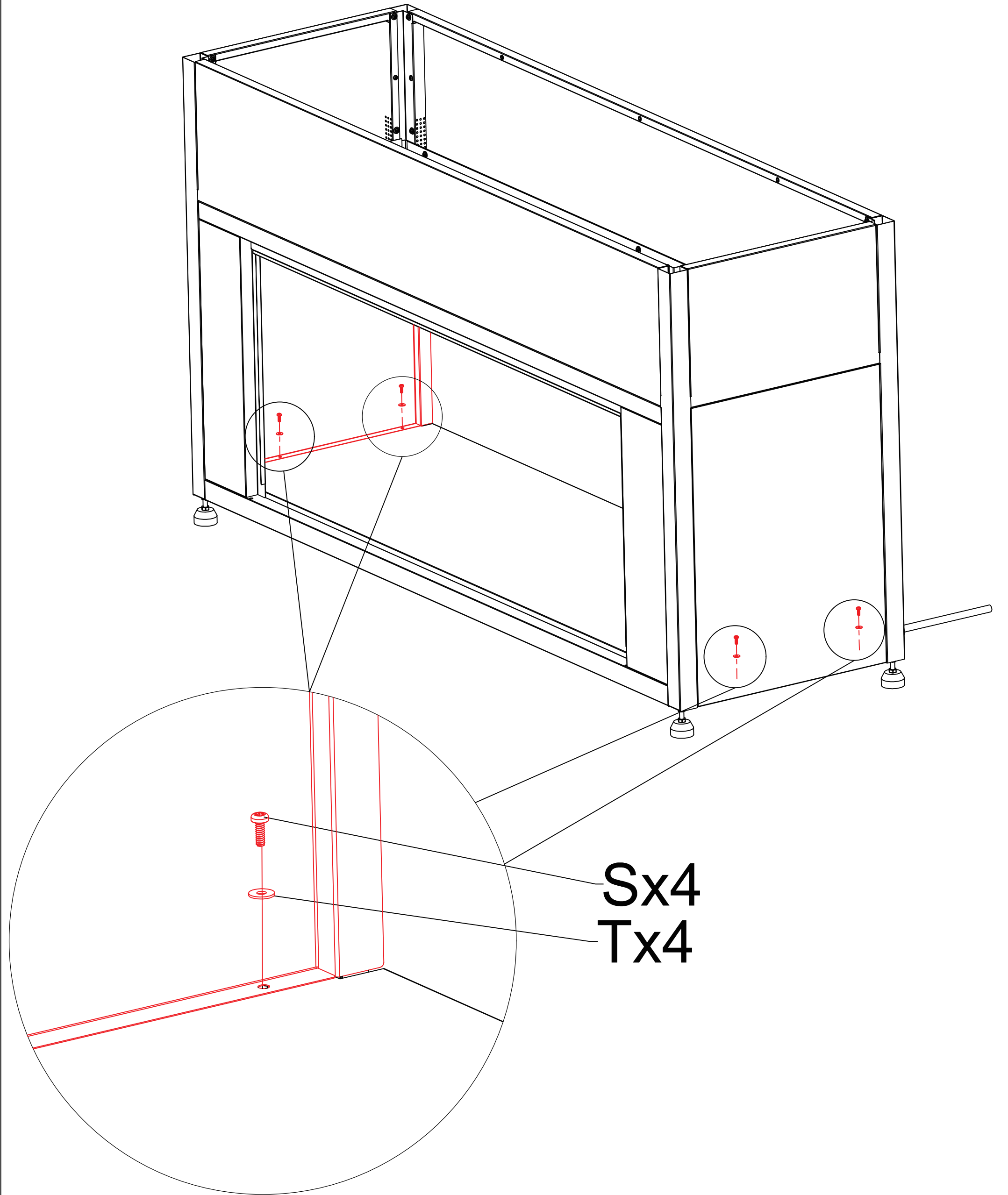

STEP8

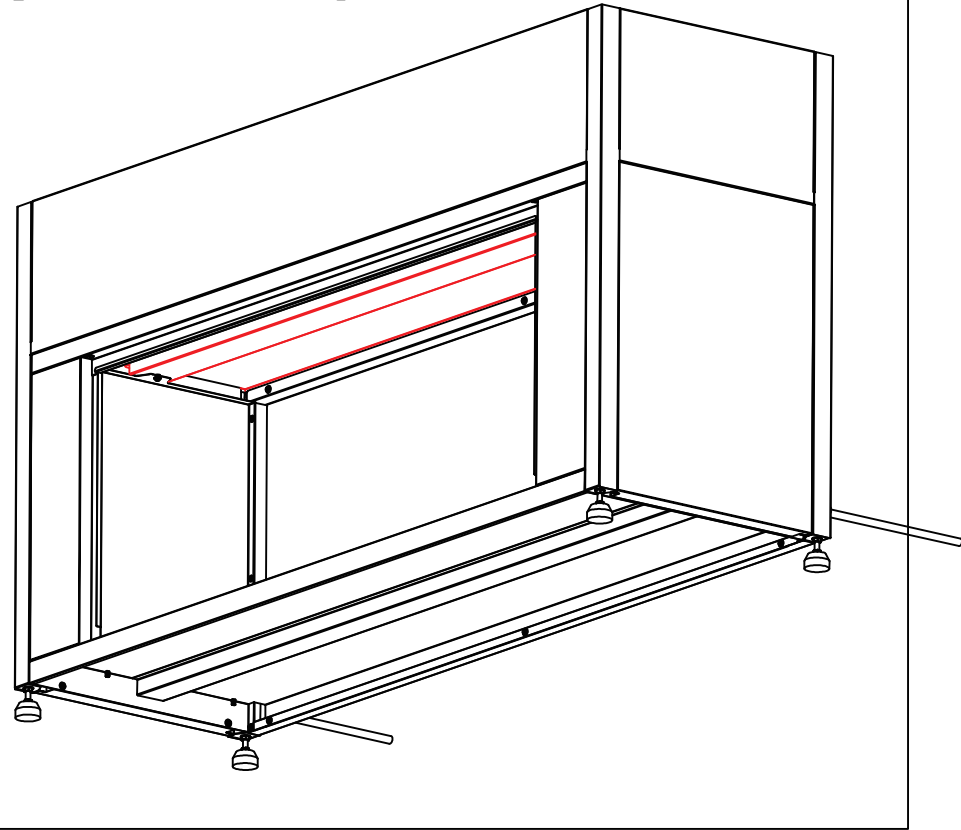

STEP8-1

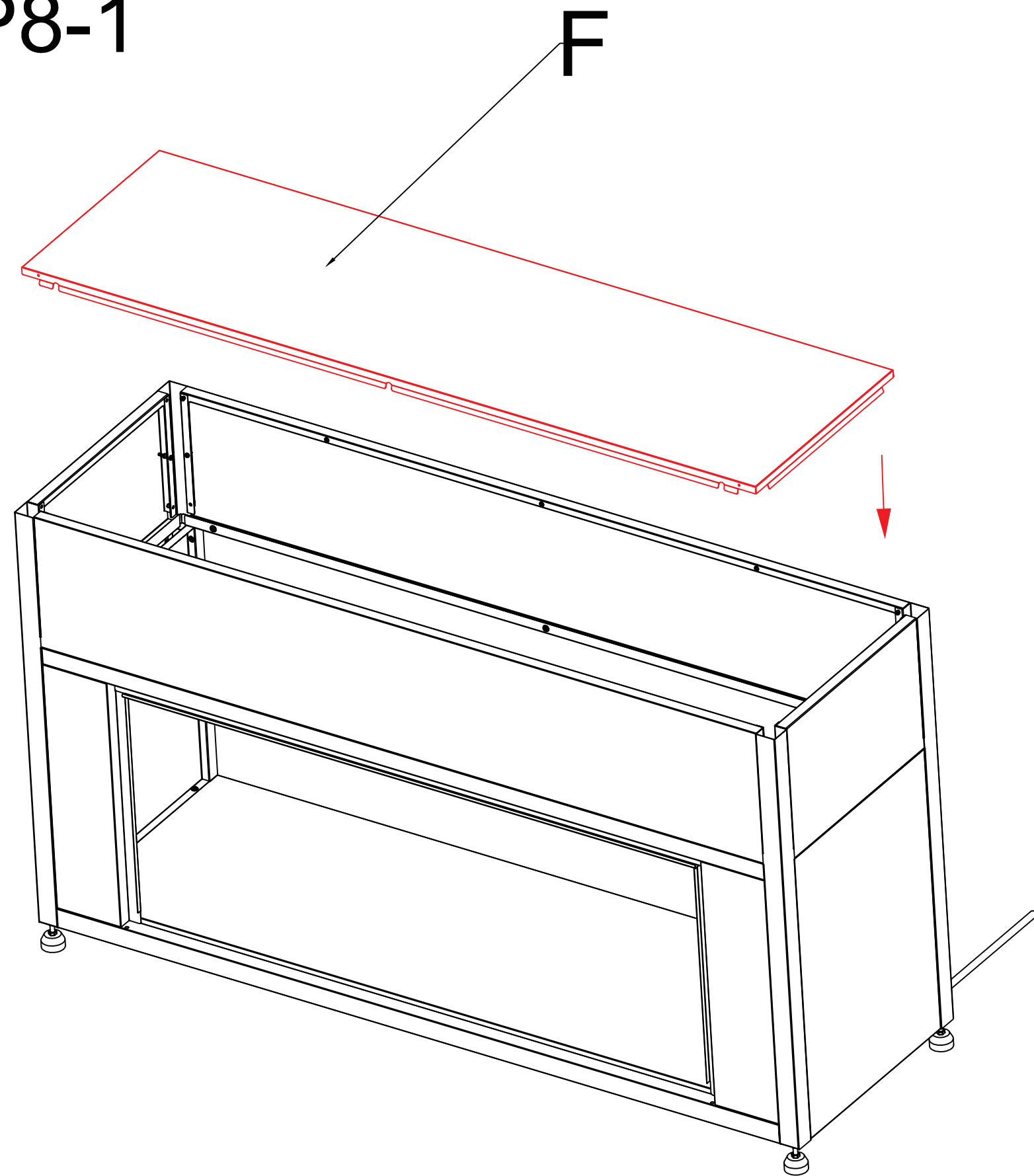

STEP8-2

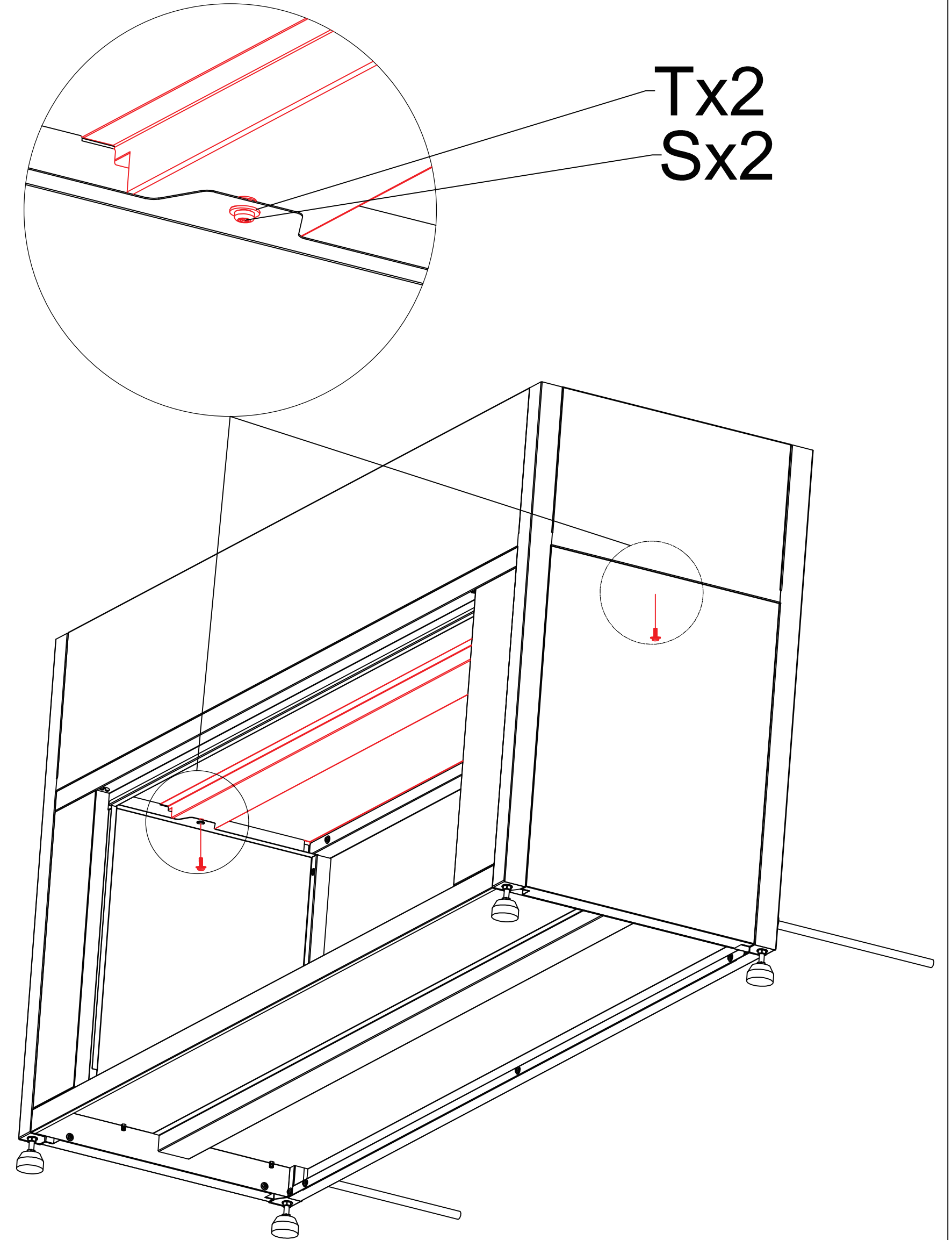

STEP9

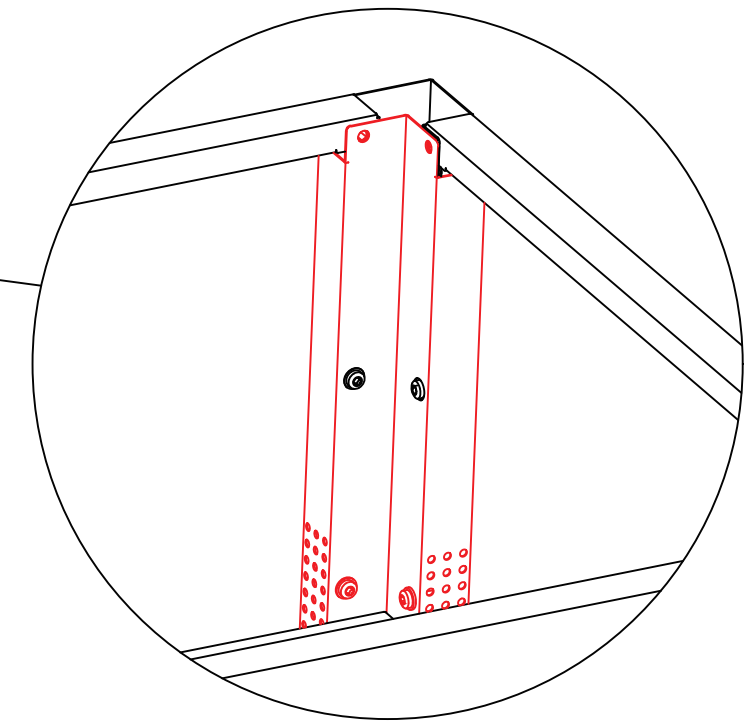
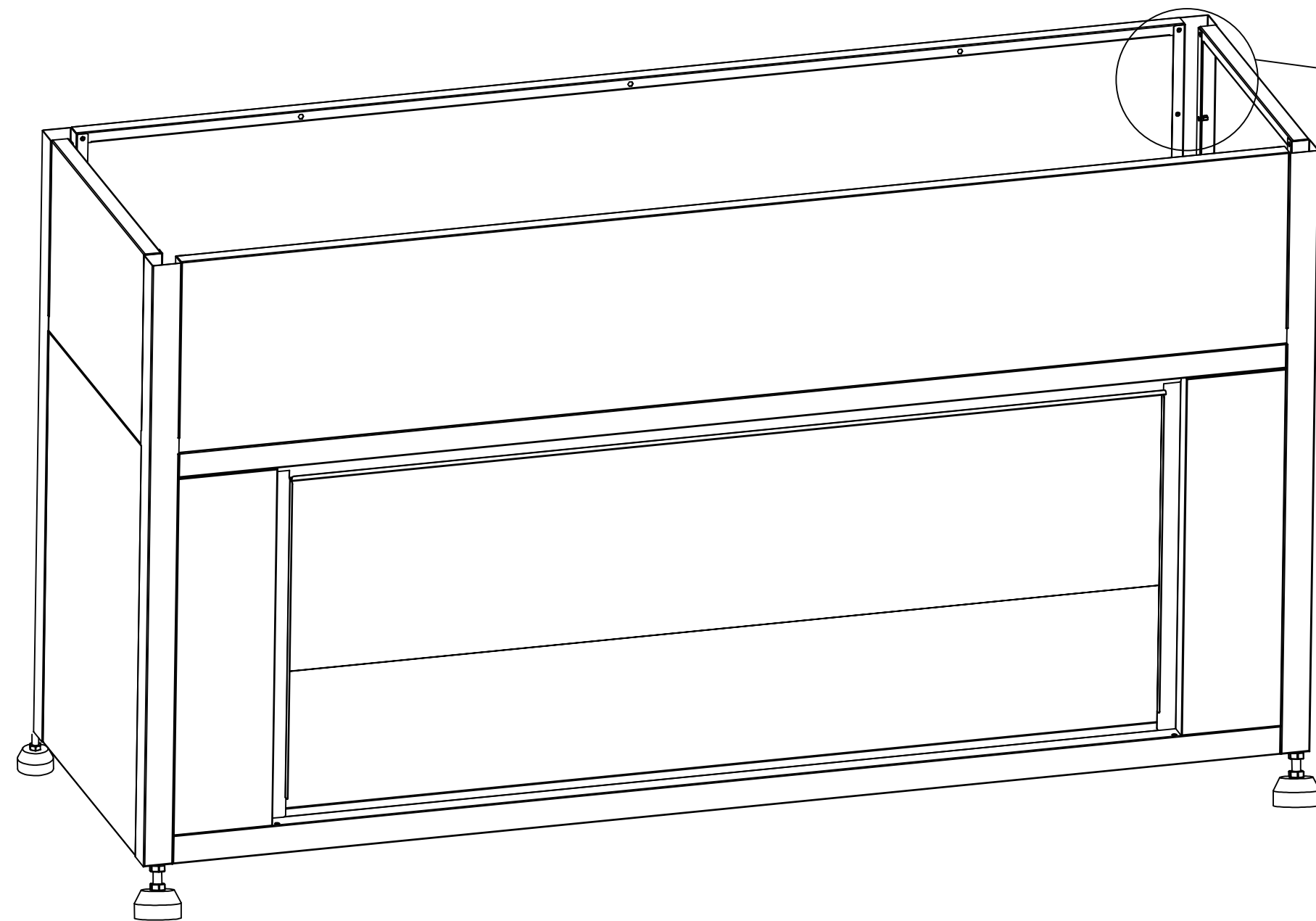
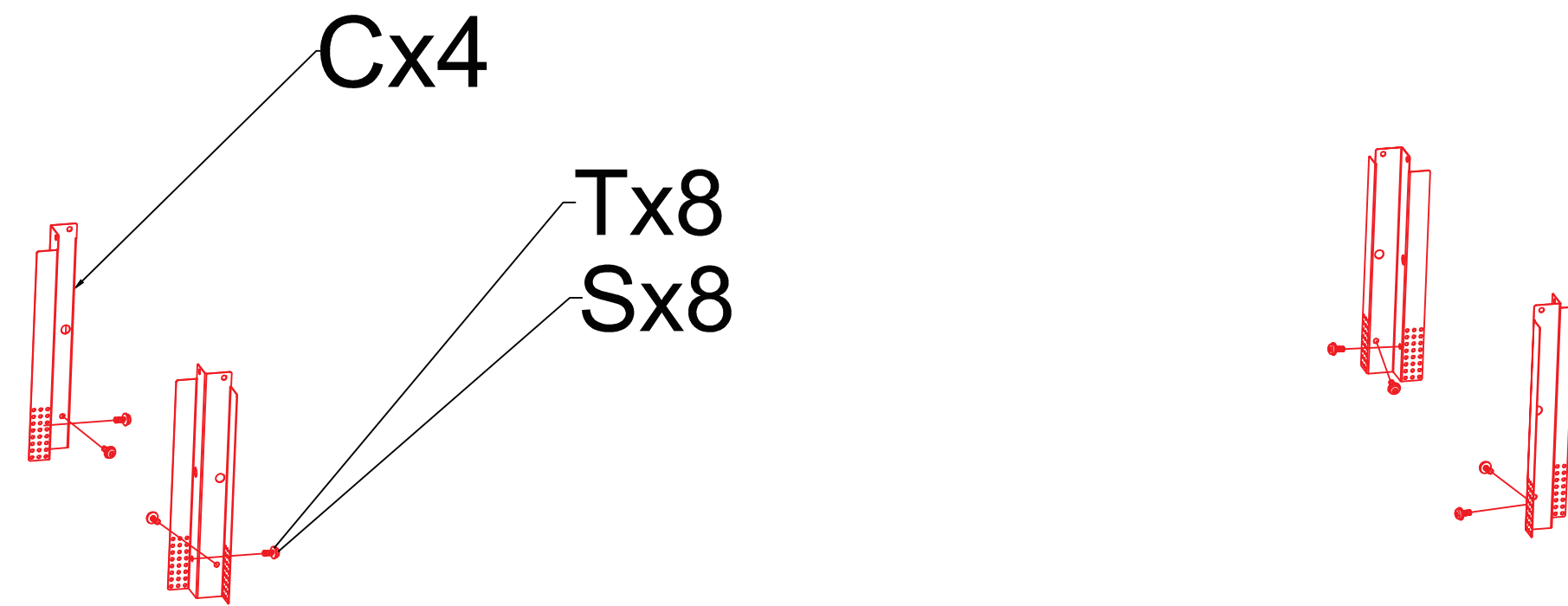
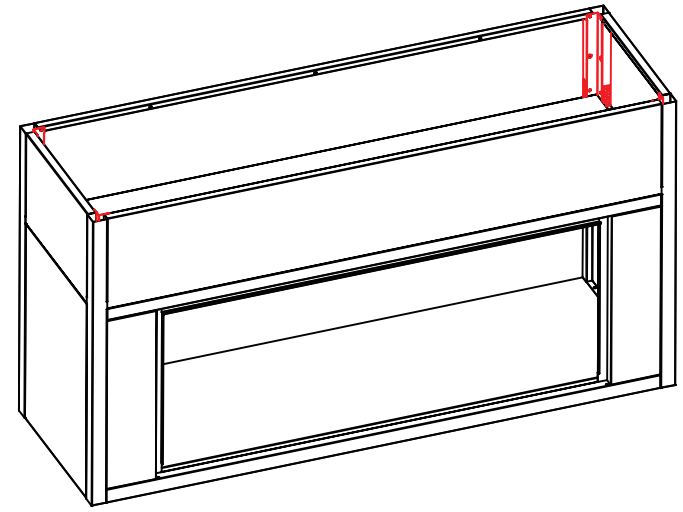

STEP10

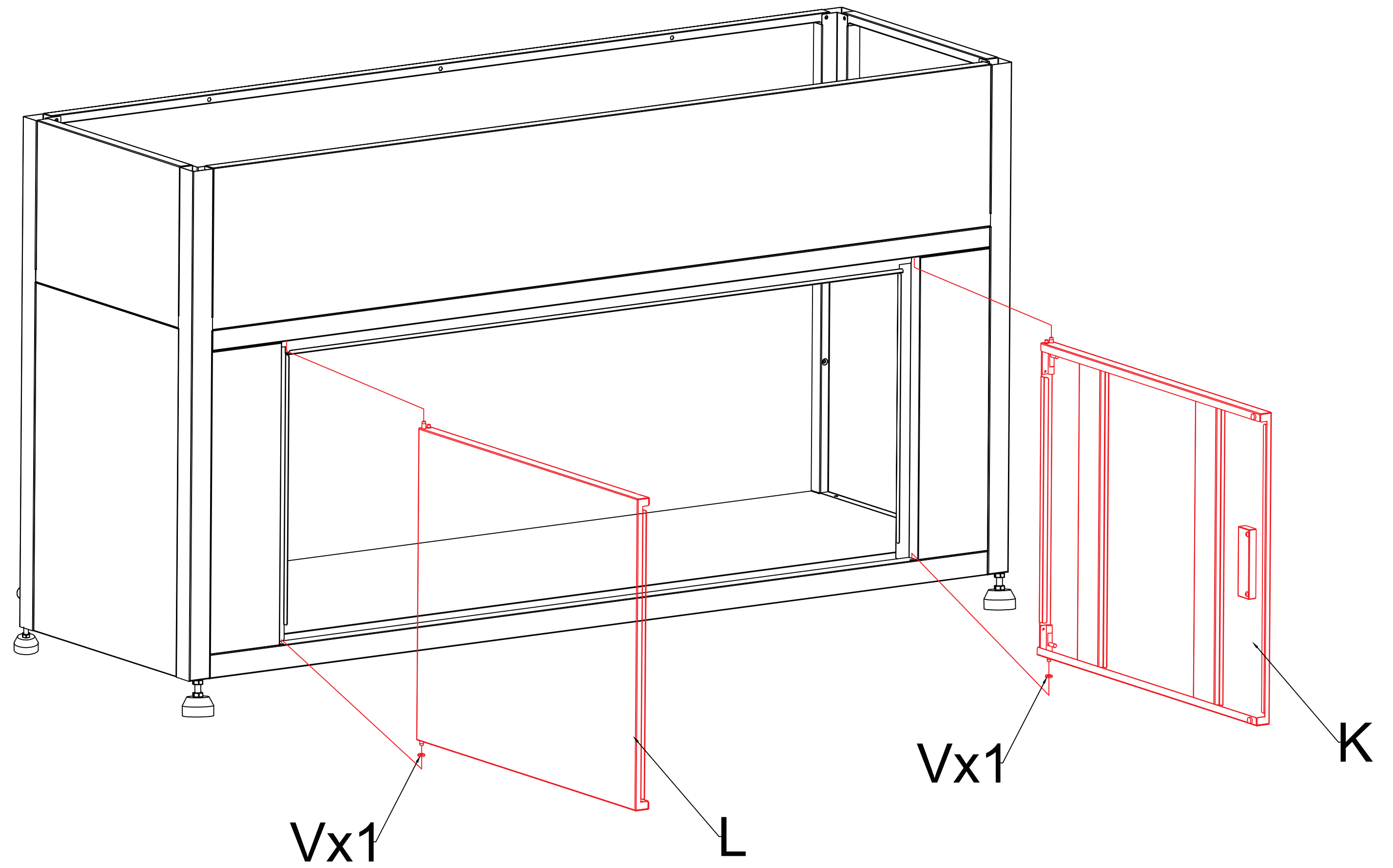
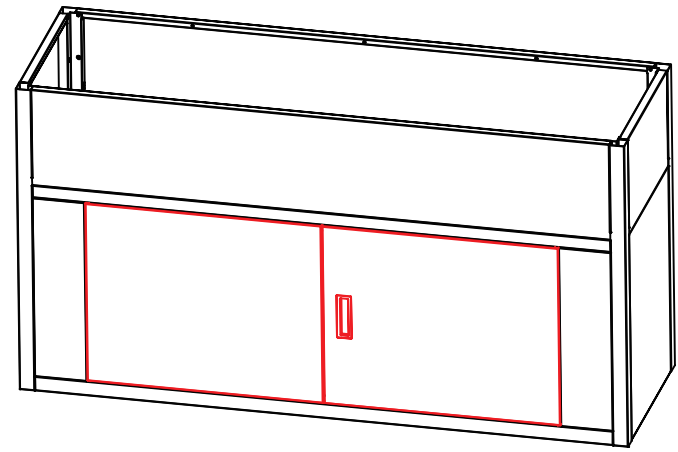

STEP11

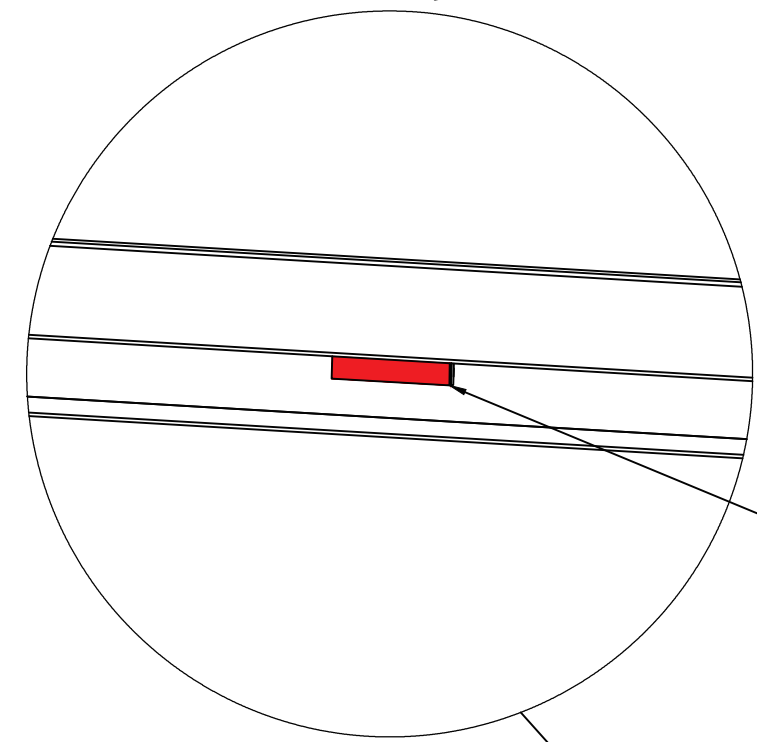
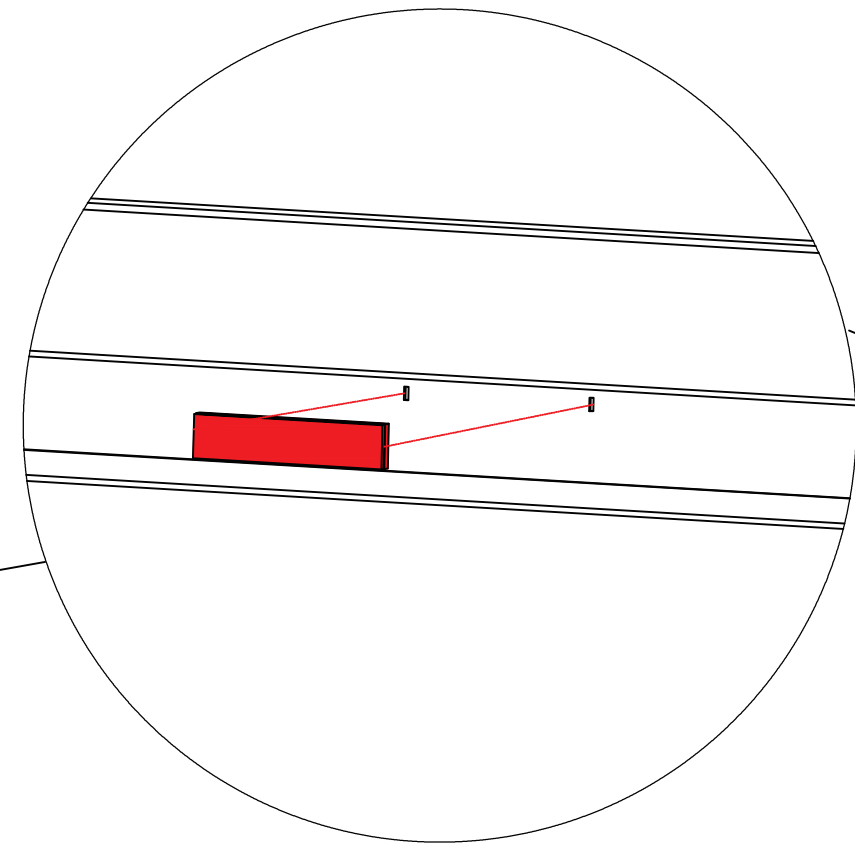
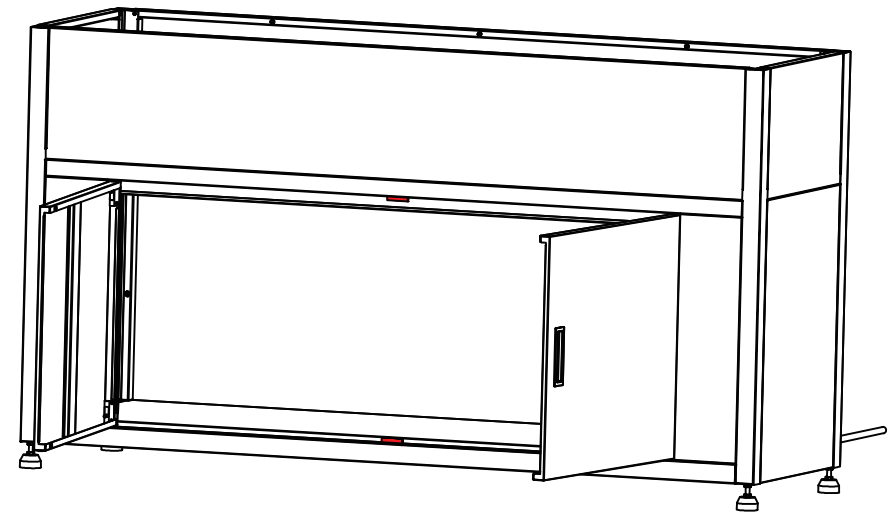

Yx2

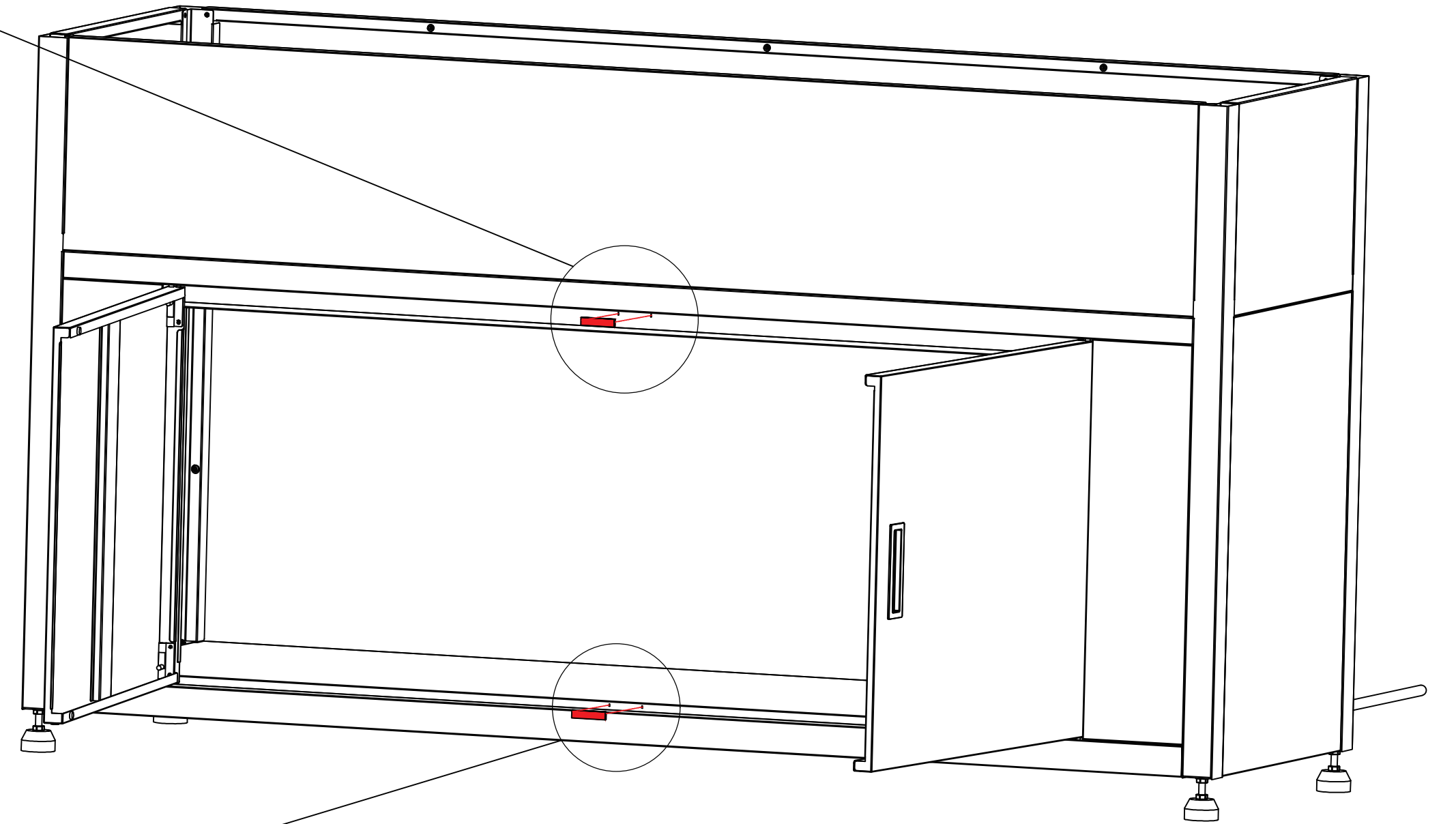
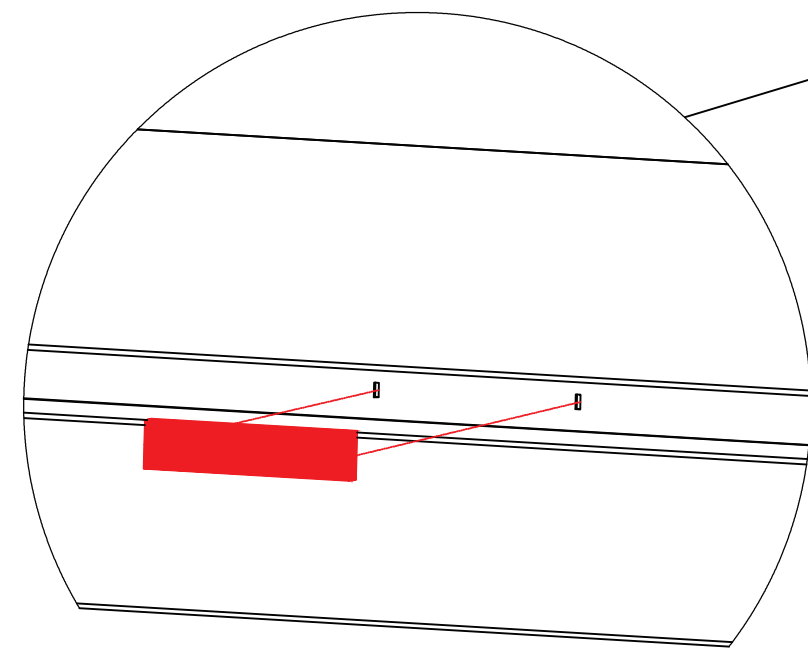

STEP12

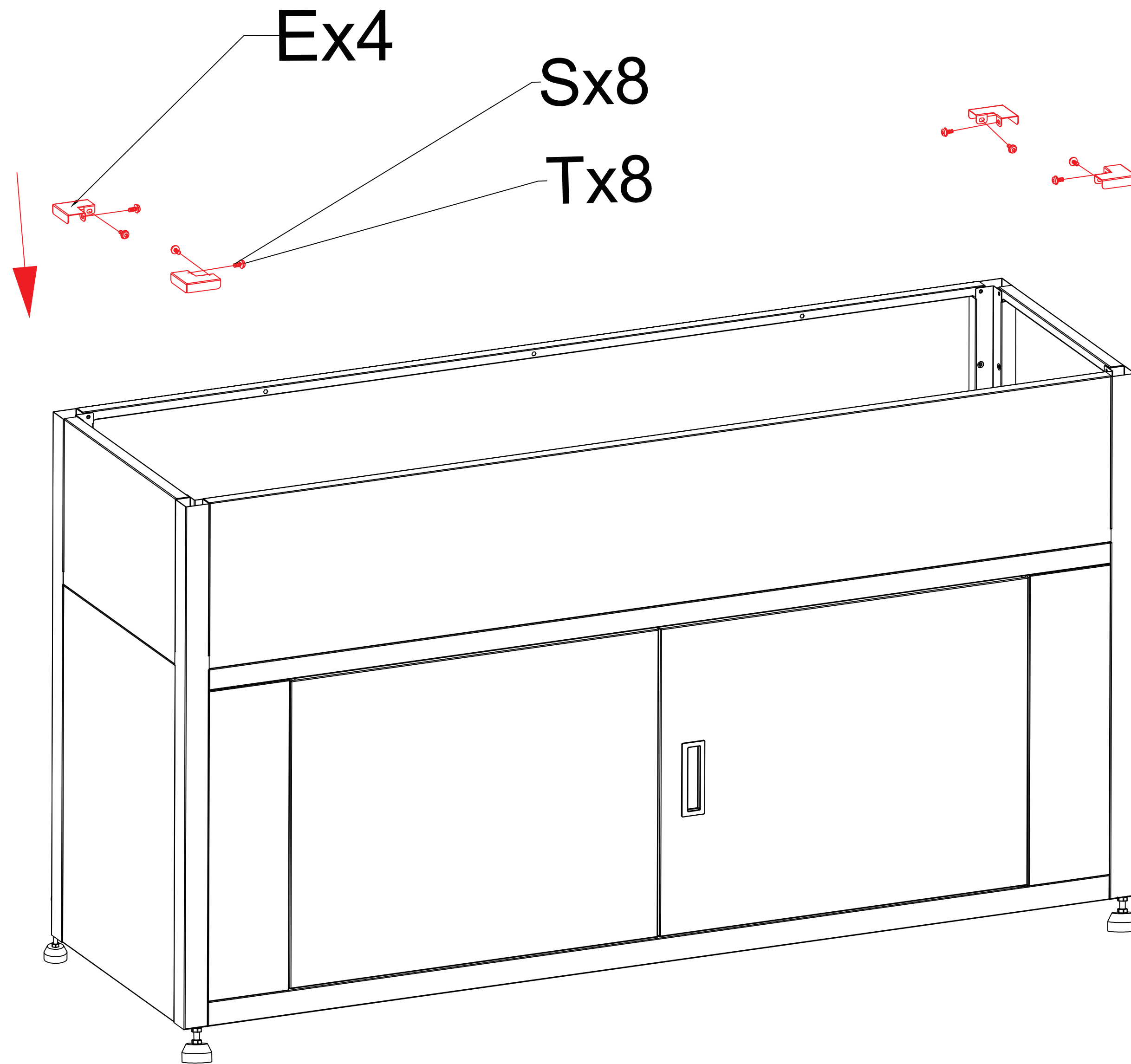
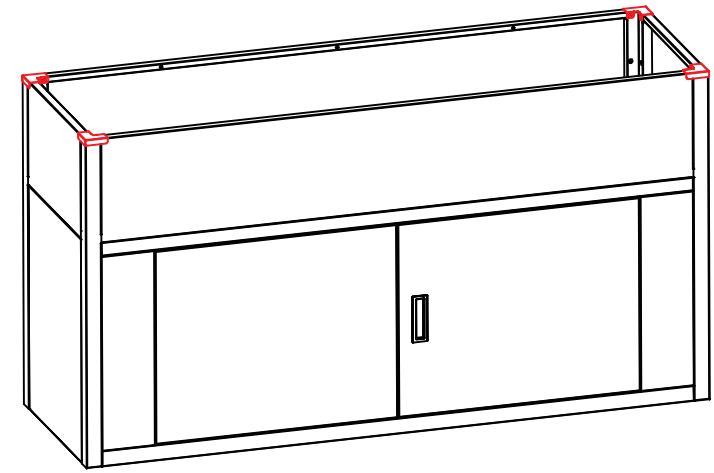

STEP 13

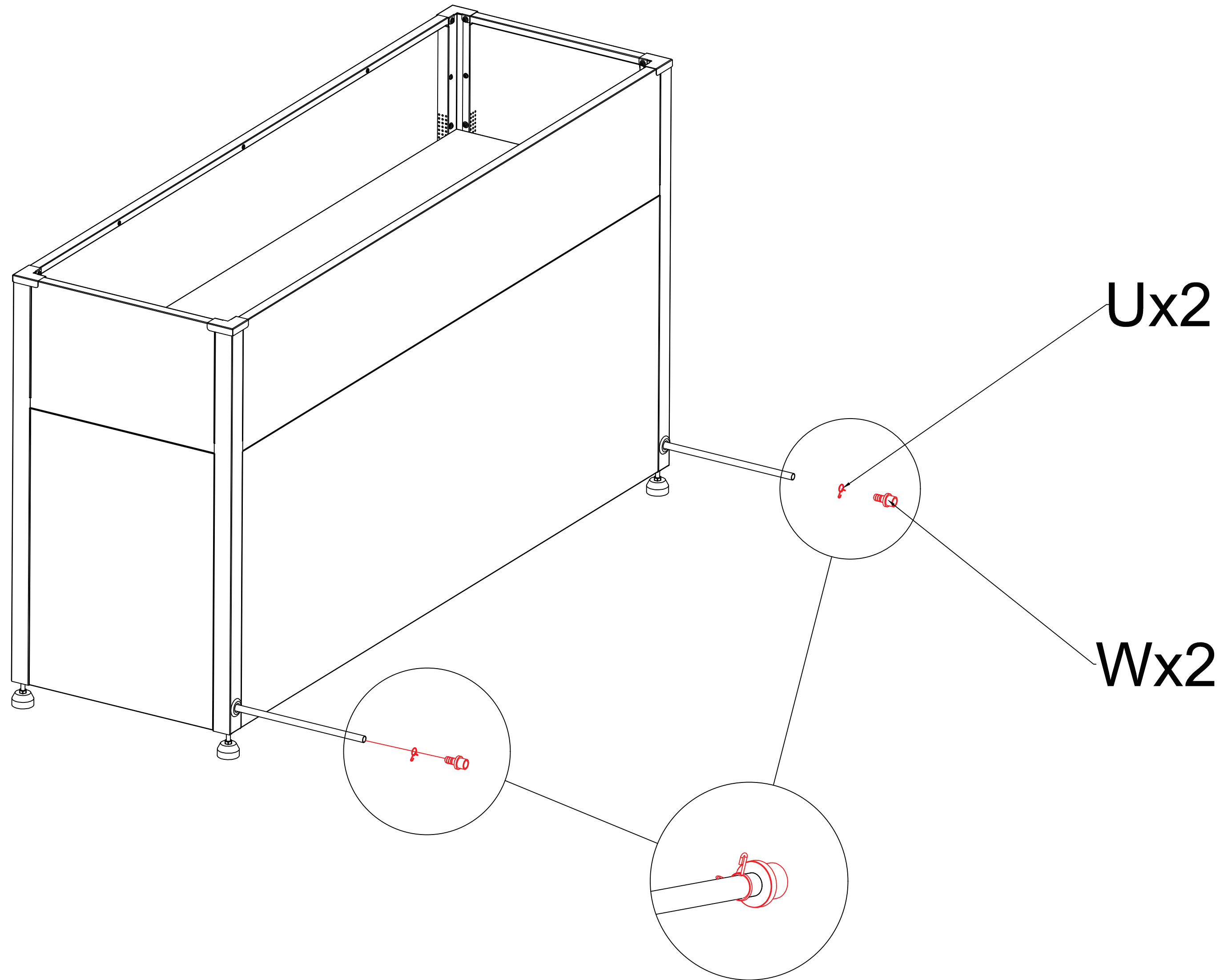
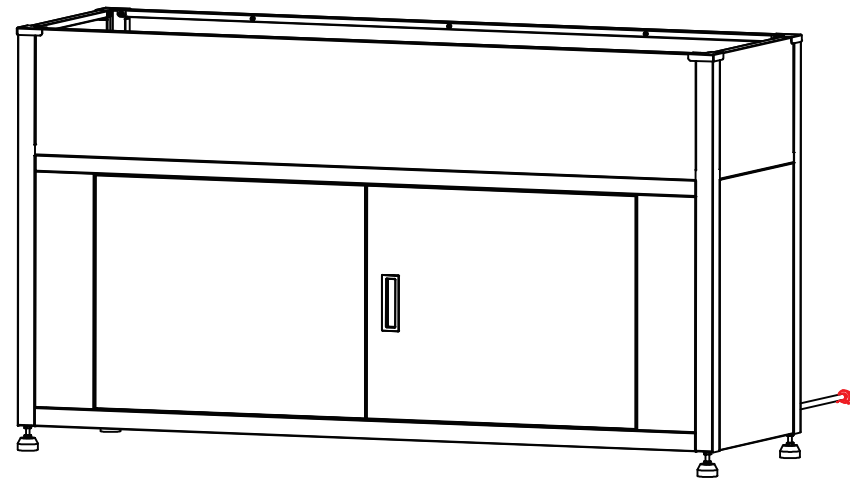

Hersteller:

Metzler GmbH, Täleswiesenstr. 9, D-72770 Reutlingen, Germany

EU-Bevollmächtigter:

Metzler GmbH, Täleswiesenstr. 9, D-72770 Reutlingen, Germany

Wichtige Sicherheitshinweise / Important Safety Information / Informations de sécurité importantes / Informazioni importanti sulla sicurezza

Scharfe Kanten / Sharp Edges / Bords tranchants / Bordi taglienti

- DE: Vorsicht beim Auspacken und bei der Installation – Handschuhe tragen.
- EN: Caution during unpacking and installation – wear gloves.
- FR: Prudence lors du déballage et de l'installation – porter des gants.
- ES: Precaución al desembalar e instalar – usar guantes.

**Montagehinweis / Installation Notice / Avis d'installation / Avviso di installazione**

- DE: Fest an stabiler Wand/Pfosten montieren; passende Schrauben und Dübel verwenden.
- EN: Mount securely to a stable wall/post; use appropriate screws and anchors.
- FR: A fixer solidement sur un mur/poteau stable; utilisez des vis et des chevilles appropriées.
- ES: Monte firmemente en una pared o poste estable; use tornillos y anclajes adecuados.

Kindersicherheit / Child Safety / Sécurité des enfants / Sicurezza dei bambini

- DE: Nicht in Reichweite von Kindern montieren. Enthält Kleinteile – Erstickungsgefahr.
- EN: Install out of children's reach. Contains small parts – choking hazard.
- FR: Installer hors de portée des enfants. Contient de petites pièces – risque d'étouffement.
- ES: Instalar fuera del alcance de los niños. Contiene piezas pequeñas – peligro de asfixia.

**Haftungsausschluss / Disclaimer / Avertissement / Esclusione di responsabilità**

- DE: Der Hersteller haftet nicht für Schäden, die durch unsachgemäße Handhabung entstehen.
- EN: The manufacturer is not liable for damages caused by improper handling.
- FR: Le fabricant décline toute responsabilité pour les dommages causés par une utilisation inappropriée.
- ES: El fabricante no se hace responsable de los daños causados por un uso inadecuado.

Umwelt- und Entsorgungshinweise / Environmental and Disposal Information / Informations sur l'environnement et l'élimination / Informazioni ambientali e sullo smaltimento

- DE: Entsorgen Sie Verpackung und alte Produkte umweltgerecht.
- EN: Dispose of packaging and old products in an environmentally friendly way.
- FR: Disposez des emballages et des produits usagés de manière écologique.
- ES: Elimine los embalajes y los productos antiguos de forma ecológica.

