

The diagram above is just for reference. Please take the appearance of the actual product as the standard.

Balance Type Gas Water Heater

Instruction Manual

Model: CCEM11GBNOX
CCEM11GNNOX



PIN:2806DQ0373

Thank you very much for purchasing our water heater.
Before installing and operating your water heater, please
read this manual carefully and keep it for future reference

TABLE OF CONTENTS

TITLE	PAGE
1. CAUTIONS	2
2. PRODUCT INTRODUCTION	4
3. UNIT INSTALLATION	9
4. METHODS OF USING	17
5. MAINTENANCE	21
6. TROUBLESHOOTING	21
7. GUIDELINES FOR GAS SOURCE CONVERSION.....	24

The heater corresponds to requirements of CE standard, and accord with the following directives:

- (EU)2016/426 Appliances burning gaseous fuels.
- 2014/30/EU Directives for the electromagnetic compatibility.
- EN 26:2023 Gas-fired instantaneous water heaters for the production of domestic hot water.
- EN 60335-2-102 Household and similar electrical appliances Safety Part 2-102: Particular requirements for gas, oil and solid-fuel burning appliances having electrical connections.
- EN 55014-1 Electromagnetic compatibility — Requirements for household appliances, electric tools and similar apparatus —Part 1: Emission.
- EN 61000-3-2; Electromagnetic compatibility (EMC) Part 3-2: Limits Limits for harmonic current emissions (equipment input current ≤ 16 A per phase).
- EN 60335-1 non-electronic heating apparatuses for home use and other similar uses.

1. CAUTIONS

1.1 Special Cautions

When the water heater is working, gas combustion would consume a large amount of oxygen and exhaust much carbon monoxide. In view of the great harm to the human health or even death caused by excessive carbon monoxide inhalation, the company sincerely advises all users that:

- The water heaters must be correctly installed and used according to the requirements of this manual.
- The water heater must be installed in rooms, do not install outdoors.
- The appliance shall be reliably earthed.
- The appliance shall be installed according to the National and local rules in force.
- This appliance can be used by children aged from 8 years and above and persons with reduced physical, sensory or mental capabilities or lack of experience and knowledge if they have been given supervision or instruction concerning use of the appliance in a safe way and understand the hazards involved. Children shall not play with the appliance.

Cleaning and user maintenance shall not be made by children without supervision.

If the supply cord is damaged, it must be replaced by the manufacturer, its service agent or similarly qualified persons in order to avoid a hazard.



WARNING

We shall not be liable for any accident arising from unauthorized disassembly or failure to cooperate on this instruction manual.

1.2 Prevention of Gas Accident

- Confirmation of category of gas: the category of gas used must be identical to that specified on the nameplate of the water heater without prior permission, and no forced use of different categories of gas.
- Make sure that the burner has gone out after use, and don't forget to close the main gas valve.
- Examine the leak tightness of each joint and pipeline frequently. Under normal conditions, the rubber pipes shall be replaced once every year.
- For the users of liquefied petroleum gas, if it is found that the flame of the water heater is high one minute and low the next, the decompression valve at the exit of gas vessel maybe breaks down. At this moment, stop use of the water heater and replace with a qualified decompression valve.
- For the users of natural gas, when the flame is found abnormal (due to instability of gas pressure in the pipelines), stop using of the water heater temporarily, If it is forced to be used, the heater may be damaged, even resulting in an accident.
- If the leakage is found, don't ignite or operate the switches of any kinds of electrical appliances, and don't make calls. Close the main gas valve immediately, open all the doors and windows to exhaust the leaked gas outdoors automatically, stop using the water heater, and contact with the maintenance department or the gas company.
- The water heaters are strictly forbidden to work with failure. If a heater breaks down, please contact with the repair center of our company in time.
- This water heater can be only used for hot water supply or shower. Do not use it for other purposes.
- The exhaust outlet must be installed at the position of air circulation, and the exhaust outlet shall be checked and cleaned regularly to avoid blockage.

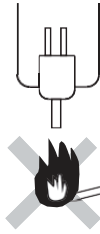

No smoke and fire

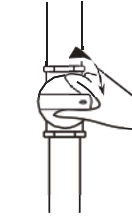
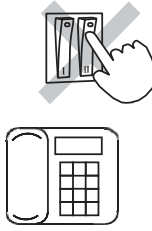

Close gas valve

1.3 Guards Against Fire

- It is absolutely forbidden to leave home or go to sleep under the circumstance that a water heater hasn't gone out.
- No inflammable goods placed near the fume hood of a water heater. The air intake and the exhaust exit shall not be covered by towels, clothing, etc.

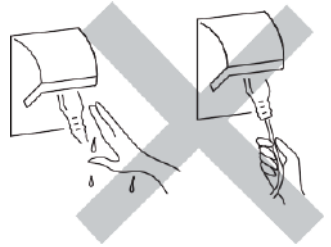
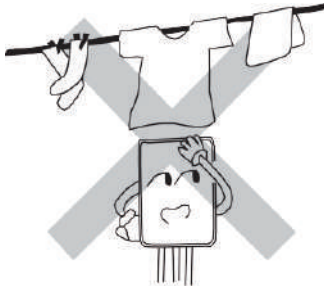

1.4 Other Cautions

- Preventing scald due to overheat: If the use of a water heater is restored immediately after the hot water valve is closed, do not contact the hot water until several seconds later, to prevent the skin burned due to too high transient temperature rise.
- Improper for drinking water supply: since there is water stored in a water heater for a long time, the hot water supplied by the heater can only be used for general purposes, but not suitable for drinking.
- Prevention of electric accident
 - ① Take the electrical plug out before clean or maintenance
 - ② Do not touch the receptacle with a wet hand, as this will have the risk of electric shock.
 - ③ Please insert the power supply plug securely on the plug. A dusty or loose plug might be the cause of an electric shock or fire.
 - ④ Do not pull out the plug by pulling the power cord, as this might break the internal wire of the cord and further lead to wire heating or a fire.
 - ⑤ This unit must be connected to a ground wire. Make sure the ground wire is connected properly.
- During ignition, it is strictly forbidden to let the eyes close to the observation hole to examine the ignition conditions. The distance between eyes and observation hole shall be larger than 300mm.

2. PRODUCT INTRODUCTION

2.1 Nomenclature

CCEM11GBNOX CCEM11GNNOX

The nomenclature can end in GBNOX that the product is compatible with LPG gas while if it ends in GNNOX, it means that the product is compatible with Natural Gas



NOTE

This manual is applicable to the forced-exhaust and balance water heaters manufactured by this company.

2.2 Technical Nomenclature

Flue gas pipe length

Model		CCEM11GBNOX				CCEM11GNNOX	
CE-Pin							
Power Consumption	W	38				38	
Rated Voltage	V.ac	230~				230~	
Frequency	Hz	50				50	
Gas							
Gas Category		I _{3P(37)}	I _{3B/P(30)}	I _{3+(28-30/37)}		I _{2H}	
Gas Type		G31	G30	G30	G31	G20	
Gas pressure	mbar	37	30	28-30	37	20	
Power							
Nominal Heat Input(Q)	kW	22				22	
Nominal Useful Output	kW	19.8				19.8	
Minimum Heat Input	kW	≤8				≤8	
Minimum Useful Output	kW	7.1				7.1	
Efficiency of energy sources		88%				88%	
Water supply pressure							
Max. water pressure	bar	10				10	
Min. water pressure	bar	0.2				0.2	
Max. water pressure	MPa	1.0				1.0	
Min. water pressure	MPa	0.02				0.02	
Max.waterflow(2bar)	L/min	15.0				15.0	
Min.waterflow(2bar)	L/min	6.3				6.3	
Connections							
Gas connection	inch	1/2"				1/2"	
Cold water connection	inch	1/2"				1/2"	
Hot water connection	inch	1/2"				1/2"	
Flue gas pipe diameter(D)	mm	Φ 60-100(C12) / Φ80(B22)					
Maximum temperature ofexhaust pipe Q Hi**	°C	150					

Flue gas pipe length						
Max. length of flue pipe	m	4(for C12 and B22)			4(for C12 and B22)	
Min. length of flue pipe	m	0.7 (for B22) 0.9 (for C12)			0.7 (for B22) 0.9 (for C12)	
Max. quantity of elbow	pc	1			1	
Net dimensions / net weight						
Dimensions (L×W×H)	mm	530x335x182			530x335x182	
Weight	kg	10.7			10.7	
Gross dimensions / net weight						
Dimensions	mm	690x407x255			690x407x255	
Weight	kg	12.5			12.5	
Table of nozzle pressure						
nozzle						
Diameter of nozzle	mm	Φ1.04			Φ1.55	
Quantity of nozzle	unit	7			7	
ERP						
Declare load profile		M				M
Water heating energy efficiency class η		A				A
Water heating energy efficiency η _{WH}	%	78.54	79.83	79.83	78.54	80.63
Daily Electricity consumption	kWh	0.076	0.079	0.079	0.076	0.078
AEC	kWh	17	17	17	17	17
Annual fuel consumption AFC	GJ	6	6	6	6	6
NOx	mg/ kWh	≤67.2	≤72.8	≤72.8	≤67.2	≤56
Indoor sound power level L _{WA}	dB	58				62
Operation temperature	°C					35-60
Protection type		IPX4 (C12)				
Type of installation		C12/ B22				
Category	Countries					
I _{3B/P(30)}	AL, BA, BE, BG, CY, CZ, DK, EE, FI, FR, GB, GR, HR, HU, IT, LT, LU, LV, MD, MK, MT, NL, NO, RO, RS, RU, SE, SI, SK, TR, UA					
I _{3P(37)}	BE, CH, CZ, ES, FR, GB, GR, HR, IE, IT, LT, NL, PL, PT, SI, SK, TR					
I _{2H(20)}	AL, AT, BA, BG, CH, CY, CZ, DK, EE, ES, FI, GB, GE, GR, HR, IE, IT, LT, LU, LV, MD, MK, MT, NO, PT, RO, RS, RU, SE, SI, SK, TR, UA					
I _{3+(28 -30/37)}	BE, CH, CY, CZ, ES, FR, GB, GR, IE, IT, LT, LU, LV, PT, SI, SK, TR					
II _{R3R}	CZ, DE, DK, EE, ES, FR, GR, IT, NO, PT, SI					
II _{3H(20)3B/P(30)}	AT, CH, CY, CZ, DK, EE, FI, GR, HR, IT, LT, NO, RO, SE, SI, SK, TR					
II _{2H(20)3P(37)}	AT, CH, CZ, ES, FR, GB, GR, HR, IE, IT, LT, PT, SI, SK					
II _{2H(20)3+(28 -30/37)}	CH, CY, CZ, ES, GB, GR, IE, IT, LT, PT, SI, SK, TR					
*request by applicant						

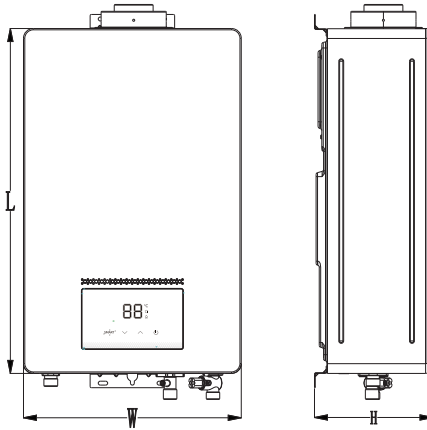

WARNING

The specifications given on the nameplate shall be taken as the standard for special category of gas. Re-equipment or changing into other gas types is not allowed!

2.3 Internal Structural Diagram

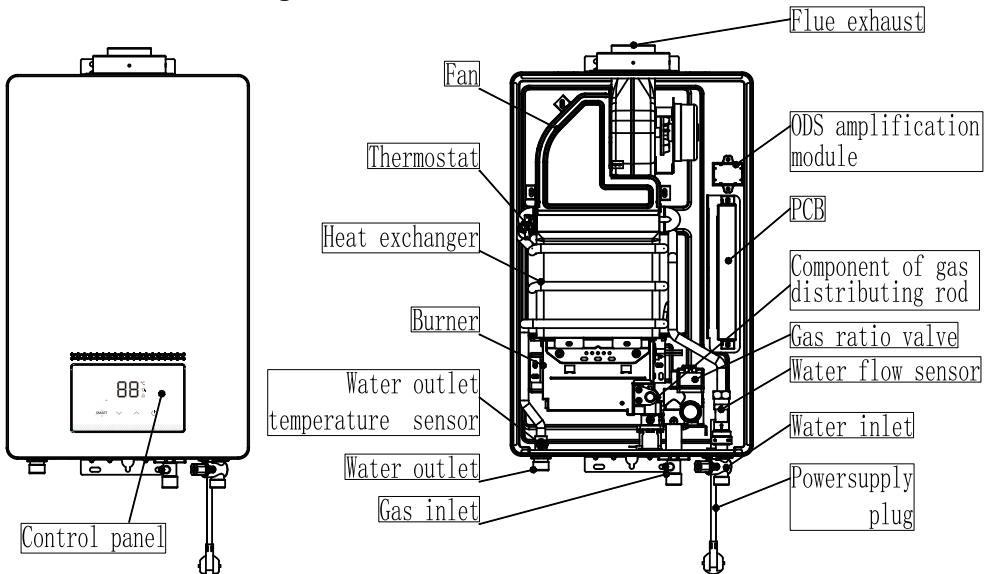

CCEM11GBNOX / CCEM11GNNOX

Note: The illustration is a reference image, your device may differ

2.4 Functional Features

- **Sealed Design:** the air inlet and exhaust are completely isolated from the air in the room, so the water heater can be installed in the bathroom.

Automatic Adjustment Of Water Temperature: advanced proportional regulator, the water temperature can be kept constant at preset temperature(35-60°C).

- **Compulsory Exhaust Device:** the waste gases of the water heater can be exhausted outdoor; at the same time, the air necessary for combustion can be inhaled into the heater compulsory. Since the air inlet and exhaust are isolated from the air in the room, the atmospheric environment will not be affected, and the air in the room is kept fresh.
- **Ultra-low Water Pressure Starting:** the hydraulic pressure for start is as low as 0.02 MPa, the applicable range is wide.
- **Flame-out Protection:** The water heater will automatically cut off the gas to ensure the gas not leaked when it flames out accidentally during the use.
- **Water-gas Interlocked Control:** The water heater will automatically stop combustion and shut down when the supply of tap water is suspended or the water valve is shut off.
- **Over-pressure Protection:** When the pressure of the water supply is too high, the safety valve of the water heater can automatically relieve pressure to avoid any damage to the water heater.
- **Convenient Removable Water Filter:** For areas where the water quality is poor, an easily removable water filter is provided specially for cleaning.
- **Brand-new Ultra-thin Appearance Design:** Multifunctional color screen display, electronic touch key control, random adjustment of water temperature, automatic constant temperature.
- **The Advanced Enclosed Combustion Chamber:** Adopts the compulsory proportional combustion mode to control combustion at the optimum state with high thermal efficiency, safe and energy saving.
- **Overheat Protection:** The water heater will automatically cut off the gas and stop working when the temperature of the water flowing out from the water heater exceeds 90 °C with inlet water temperature exceed 15°C or dry burning occurs.
- Digital display and setting of outlet water temperature, easy and convenient to use.
- Power supply indicator, burning indicator, acousto-optic diplex alarm system to attract attention of the user, safer to use.
- Ultra-large water flow, satisfying multi-point water supply simultaneously.

2.5 Internal wire Diagram

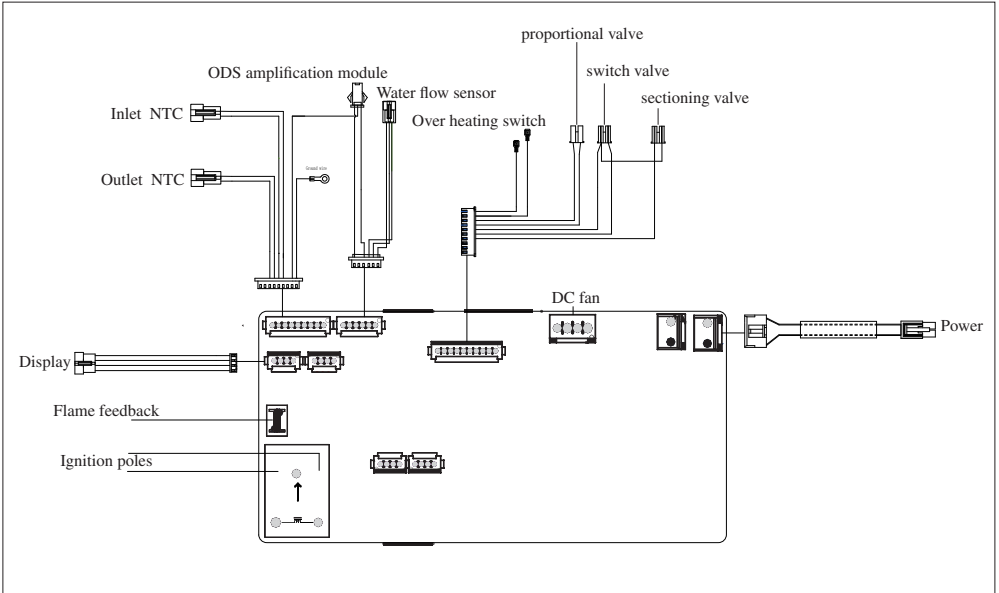

3. UNIT INSTALLATION

3.3 Installation Modes

The combustion air intake grille must locate in a well-ventilated place. To prevent corrosion, it is necessary that the combustion air is free of aggressive substances. Aggressive substances are halogenated hydrocarbons which contain chlorine or fluorine. These substances are found in solvents, paints, adhesives, gasses or liquid-propellants and household cleaners. If these conditions are not able to guarantee, another place should be chosen for the air intake.



WARNING

This unit must be installed indoors and must not be installed outdoors. Never use this unit when no compulsory gas supply and exhaust pipe is installed.

3.2 Brief Introduction



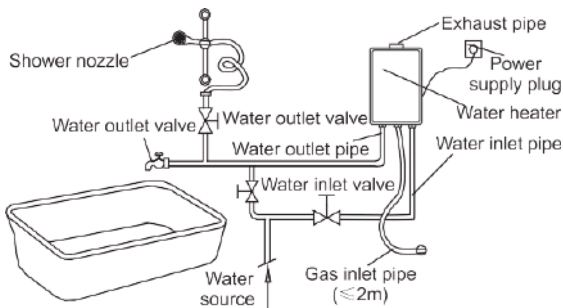

The water heater must be installed by technicians with professional qualifications for installation. Since the improper installation is liable to failures, the customers shall not install the heater by themselves. Before installation, please make sure again that the category of gas used is identical to that specified on the nameplate. The B22 gas water heater can not be installed in bathroom.



WARNING

The water outlet pipe cannot be connected to the shower nozzle directly; and a water outlet valve must be installed as shown in above illustration.

3.3 Packing List Parameters

Name and Illustrations	Quantity	Name and Illustrations	Quantity
 Water Heater	1	 Plastic Plug Tapping Screw	2
 Instruction Manual	1	 M6 Expansion Screw	1
 Seal ring	1		

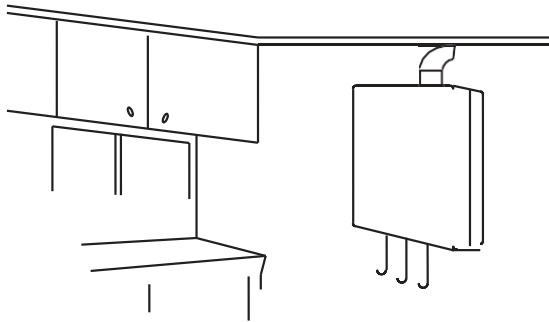

- Installation of the unit:

Mount the unit upright without inclination according to the dimension show in the following illustration.

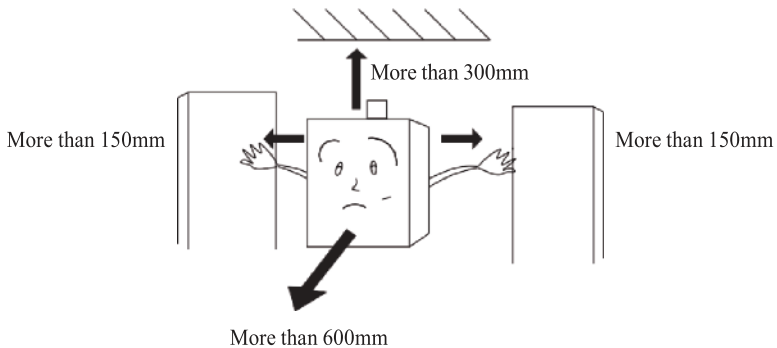

- Type of installation (C12)
- Installation of compulsory gas supply and exhaust pipe of the unit:
 - a. Installation mode of topside exhaust.

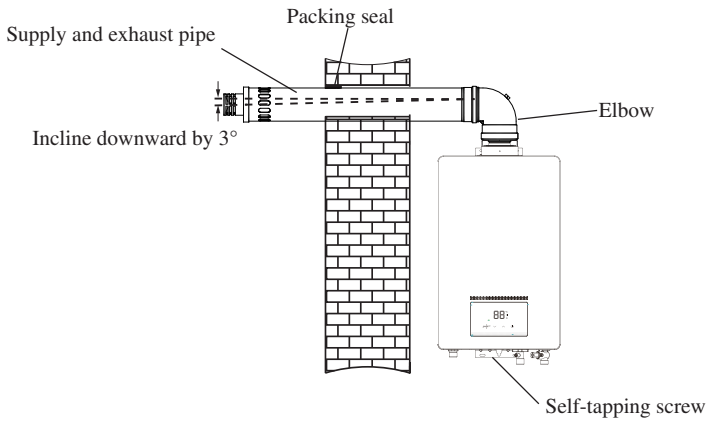

As show in the figure below, tap in expansion screws for fixation, hang the unit vertically and screw it down with nuts, insert plastic plugs below it and screw down self-tapping screws.

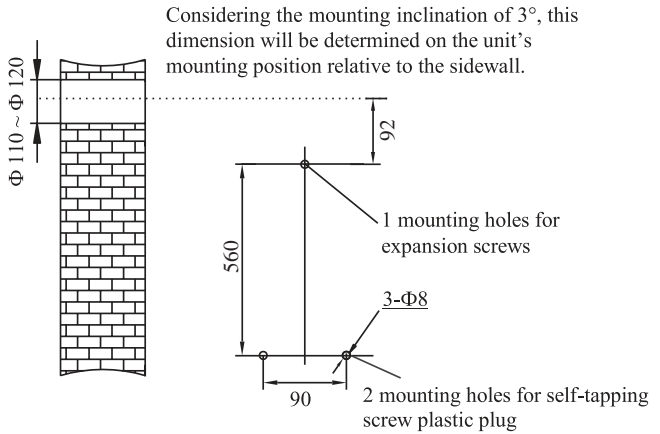

b. Installation mode of top rear exhaust.

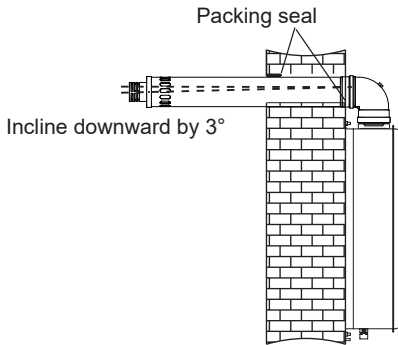

As show in the figure below, tap in expansion screws for fixation, hang the unit vertically and screw it down with nuts, insert plastic plugs below it and screw down self-tapping screws.

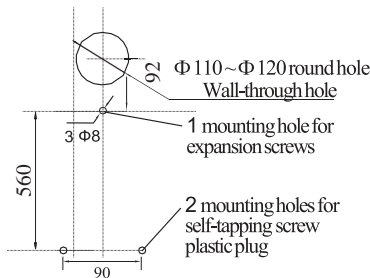

- Type of Installation (B22)
- Installation of compulsory gas exhaust pipe of the unit:
 - a. Installation mode of topside exhaust.

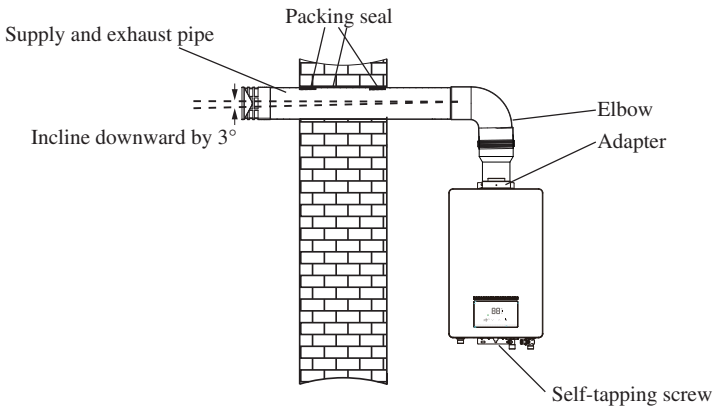

Adapter installation instruction (The adapter can be obtained from the dealer)

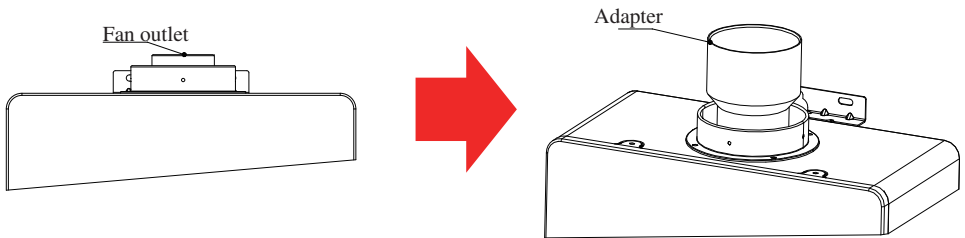

- Remove the old pipe and see the outlet of the fan.
- Insert the adapter down the fan outlet into the upper part of the fan.

Adapter overall dimension and interface dimension

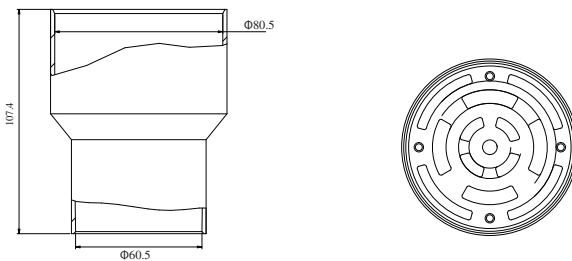

As show in the figure below, tap in expansion screws for fixation, hang the unit vertically and screw it down with nuts, insert plastic plugs below it and screw down self-tapping screws.

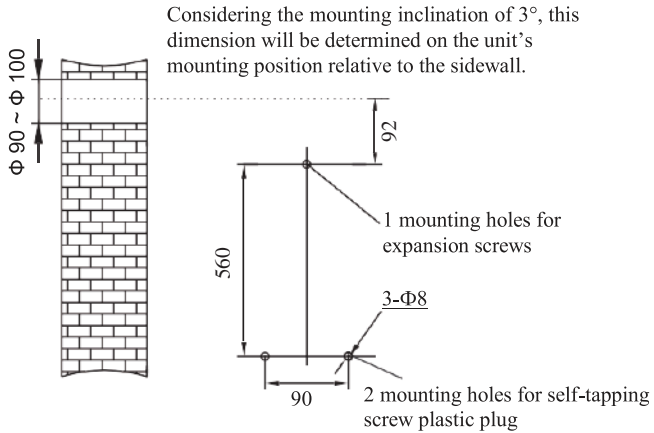

b. Installation mode of top rear exhaust.

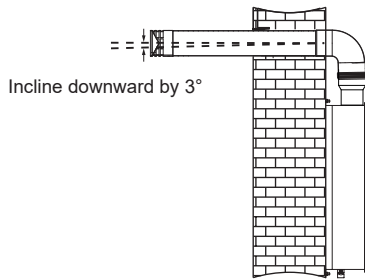

As show in the figure below, tap in expansion screws for fixation, hang the unit vertically and screw it down with nuts, insert plastic plugs below it and screw down self-tapping screws.

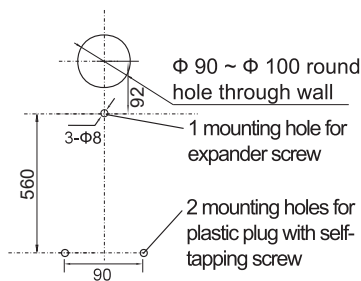

● Guidelines for Setting Long and Short Smoke Tubes

After powering on the full display, press and hold the down button for 3 seconds to display PP in the shutdown state.

Press the power button to display the FA

Press the up key to Fn, press the power button to enter Fn, press the up and down keys to set Fn, and select the length of the cigarette tube. 00 corresponds to a cigarette tube length of 0.7-3m; 01 corresponds to a long cigarette tube length of 3-4m. Press the power button to complete the setting.

Table 1: value of parameter Fn-Length of evacuation

selection of parameter Fn	
00	0.7-3m
01	≥3-4m



NOTE

The B22 gas water heater must be installed and used in well ventilated area, out-side a bathroom. If there is a wall near the smoke exhaust outlet of the smoke pipe, it is recommended that the distance between the smoke exhaust outlet and the wall be $\geq 500\text{mm}$ to prevent the wall from obstructing the smoke emission and causing the smoke to flow back into the interior of the whole machine, affecting the combustion of the whole machine

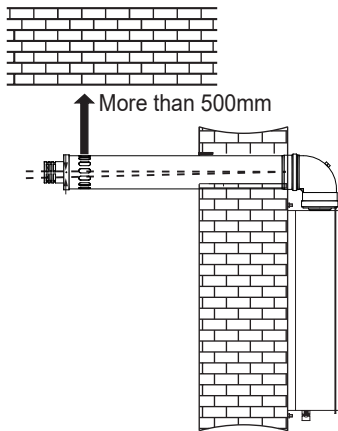

- Installation of gas pipe

- a. Caution

- ① Be sure to select a special gas rubber hose or a suitable rigid tube and a gas relief valve.
- ② Select the pipe size according to Table 1.
- ③ The length of the rubber hose shall not exceed 2 meters.
- ④ The rubber hose must be connected to the red line position of the gas inlet joint and secured with a clamp.
- ⑤ After installation, check the unit with suds for gas leak.

- b. Connect the unit to the gas joint with G1/2 pipe thread.

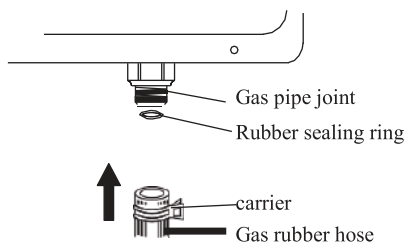

- Installation of water inlet and outlet pipes.

Connect the water inlet and outlet pipes and tap water pipe of the unit with an $\Phi 10$ mm metal hose, or with a water pipe with an inner diameter of greater than 15mm.

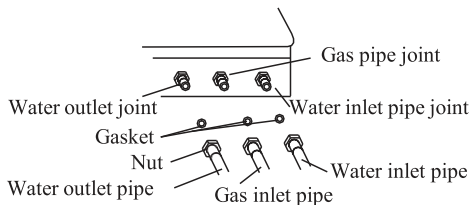

NOTE

Add a rubber sealing gasket when a metal hose is used.

3.4 Installation Caution

- Since this machine adopts compulsory air inlet and exhaust, it is permissible to be installed in the bathroom, however, the exit of exhaust system must be extended outdoors, and the distance between the end of outdoor exhaust pipe and adjacent or other articles must be larger than 600mm.
- This machine is not allowed to be installed outdoors to prevent damage of the heater caused by freezing of water.
- A water inlet valve shall be installed at the water inlet pipe of the unit, so that the water supply can be switched off in repair.
- The mounting position of the unit is made of a nonflammable material. If it is made of an inflammable or flame resistant material, a heatproof plate shall be used for heat insulation, whose distance from the wall shall be greater than 10mm.
- The lower edge of the unit shall be about 1.5m above the ground, so that its combustion can be easily observed and its temperature adjusted.
- A LPG user shall select a suitable, high-quality gas relief valve, whose specification shall not be less than 1.5m³/h to guarantee the gas pressure and flow input into the unit. ``
- Natural gas users shall use a hard metal pipe with the same diameter as the gas inlet of the unit to reduce gas closure and pressure loss.
- There should be no inflammable or explosive material around the unit and the fume exhaust port, e.g., kerosene, gasoline, alcohol, paints, paper, clothes, etc.

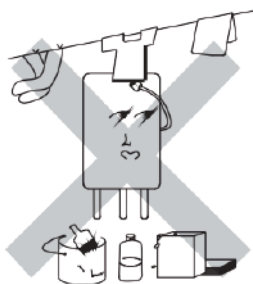

- Do not point the exhaust port directly to a nearby window when install the unit.
- The unit shall not be installed where there is corrosive gas or article, and there should be no exposed wire, electric appliance or gas pipe above it, or any gas range or baking oven below it.



- Receptacle shall be installed on the left or right side of the unit and must be grounded reliably .

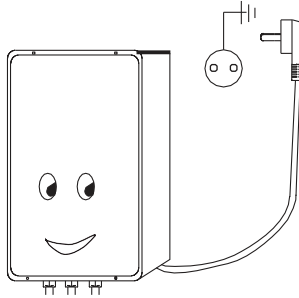

4. METHODS OF USING

4.1 Preparation Before Ignition

- Insert the power supply plug and switch on the power.
- Open the main gas valve switch.
- Open the water inlet valve before ignition.

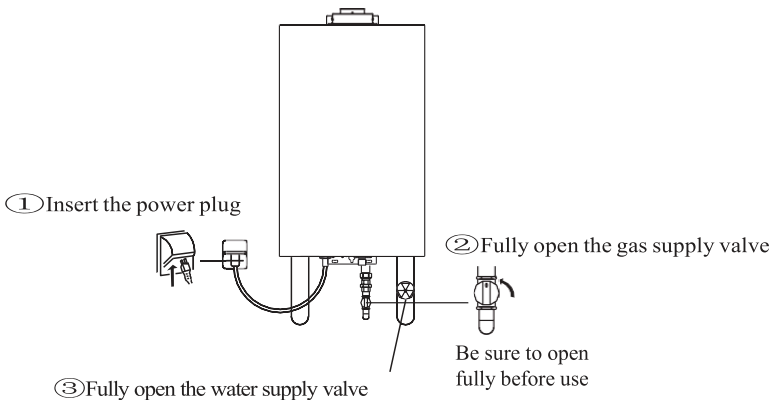

- Finish above mentioned preparation and confirmation before use.
- Press ON/OFF key on the operation panel, the LED will display the default water outlet temperature, press the \wedge/\vee key to set the hot water outlet temperature.

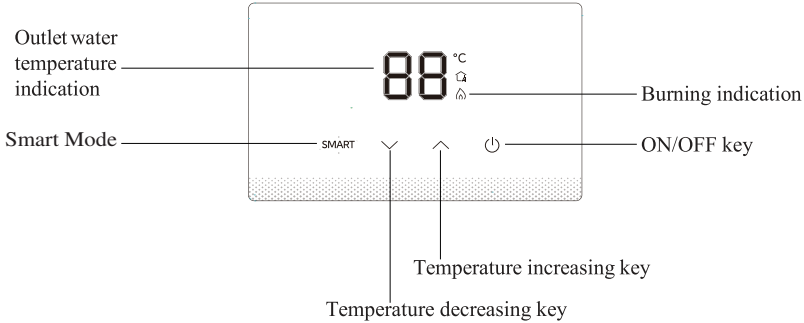

Smart Mode:

By sensing the inlet water temperature, the temperature is divided into four different intervals, each with different preset values. The preset values are shown in the table below.

Inlet water temperature / °C	Preset temperature / °C
≥ 28	40
22-27	42
16-21	44
≤ 15	46

When the inlet water temperature changes, the system will automatically set a temperature value to correspond to the preset value of the corresponding inlet water temperature range.

Anti scald protection: During the combustion process, if the temperature is set to <49 °C before entering the combustion, the maximum set temperature is 49 °C (the temperature can be adjusted to be greater than 49 °C when in standby mode). If the temperature is set to ≥ 49 °C before entering combustion, the highest set temperature is the full range

4.2 Ignition And Operation

- Ignition: Open the water outlet valve. the unit will start the exhaust device automatically and make a “frizzle” ignition sound; the LED will display the actual water outlet temperature. When the unit is running, there will be air in the gas pipe; therefore a single ignition might not work sometimes. In this case, close the hot water valve immediately and restart the unit after 10-20 seconds.



NOTE

For the first use or when the unit has not been used for a long time, operate as above repeatedly until all the air in the exhaust pipe has been discharged.

- Adjustment of water outlet temperature: The preset range of the water outlet temperature is 35-60 °C . Every time the Temp Up key is pressed, the set temperature will rise by 1 °C , every time the Temp Down key is pressed, the set temperature will down by 1 °C , the screen will display the set temperature.
- The set water outlet temperature has the memory function. However, in case of power off, the memory function will be disabled.
- Sound prompt function: In normal circumstances, every time the key on the operation panel is pressed, the buzzer will make a sound for 0.5 second. When the unit fails or the 40-minute timing protection ends, the buzzer will give out continuous alarm sounds, the combustion indicator will flash rapidly and continuously, Press the ON/OFF key, the alarm will disappear and the screen will be closed.



WARNING

To use hot water again after stop, do not let the hot water splash you, because the water temperature in the unit might be very high. Use it after several seconds of hot water outflow to avoid scald.



4.3 Stop To Use

- ① Close the water outlet valve, the unit will stop automatically.
- ② Press the ON/OFF key on the operation panel.
- ③ Close the water inlet valve.
- ④ Close the main gas switch.
- ⑤ Switch off the power switch or pull out the power supply plug.

4.4 Anti-frozen Treatment Of The Unit

- Ani-frozen water supply method:
Not only the main body, but also the cold/hot water pipes and valves can be protected from freezing. When there is a line controller, the ON/OFF key of the line controller shall be at the OFF position before you proceed with the following operations.

- ① Close the gas valve.

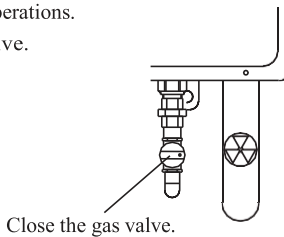

- ② Open the water outlet valve (the water inlet valve is semi-open).

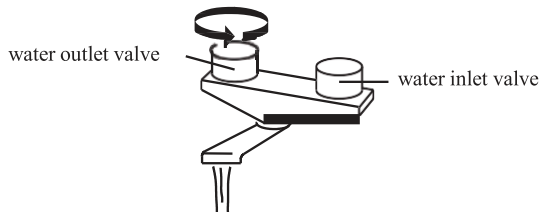



NOTE

Since the flow is unstable, please confirm the flow again 30 minutes later. In cold weathers, be sure to increase the water flow.

- Ani-frozen drainage method:

When there is a line controller, the ON/OFF key of the line controller shall be at the OFF position and the unit shall be operated as follows:

- ① Close the gas valve.
- ② Pull out the power supply plug to cut off the power.
- ③ Close the water inlet valves.
- ④ Open all water outlet valves.
- ⑤ Remove the drain valve and the filter net faucet.
- ⑥ After drainage, replace the drain valve and the filter net faucet.

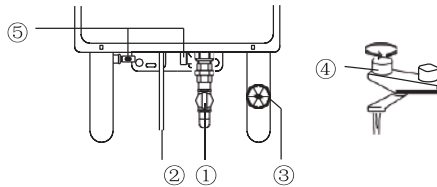

Maintain the above condition until the next operation after drainage.

- ① Open the water inlet valve, stop the water outlet when there is water outflow from the water outlet.
- ② Restart the unit in the order described in page 14 (Preparation Before Ignition)



NOTE

In case of reuse, if you don't operate as above, there might be an error.

- Cautions for anti-frozen of the unit

- ① Neither the electric heating antifreeze method nor the antifreeze drainage method can prevent freezing of the pipes and valves. All pipelines and valves from the cold water inlet to the hot water outlet shall be wrapped with heat insulation materials to prevent freezing.
- ② When freezing has occurred, be sure to thaw it. Make sure there is no water leakage and the unit is running properly before use.



WARNING

All adverse consequences of wall and floor damage arising from water leakage due to failure to take any antifreeze measure will be born solely by the user.

5. MAINTENANCE



WARNING

Take the electrical plug out before clean or maintenance.

- Check up frequently to see whether the gas supply pipelines (rubber hose) are in good conditions without aging, cracks. Pay attention to periodic replacement of rubber hoses. In order to prevent gas leakage, check the joints of pipelines frequently by using suds to see if there are bubbles given off.
- A water heater must be examined, cleaned after it has been used for a period of time (generally about half a year) to guarantee normal operation of the heater. Observe the flame frequently. When the flame turns to be yellow from blue, accompanied by black fume, the heater must be cleaned.
- Clean the casing of the unit with water and neutral cleaner other than any chemical cleaner or volatile solvent, otherwise the casing will fade and lose luster.
- Clean the filter net at the water inlet of the unit regularly.
- Wipe the casing of the unit with soft and clean cloth often.



- The water heaters must be examined, cleaned periodically by the professional personnel.
- Non-professional personnel can not open the cases of water heaters. Pull out the power plug when opening the case of a water heater. Do not wet the power socket with water in use to ensure safety.

6. TROUBLESHOOTING



WARNING

When there are any abnormal phenomena found, such as gas leakage, abnormal burning (backfire, deflaming, yellow flame or black fume, etc.), abnormal odors or sounds, etc., or other emergencies happened, close the gas valve immediately, and contact with the maintenance department or the gas company for disposal.



- Advanced error code display for more convenient operation and maintenance. Error codes:

Error codes	Description	Treatment
E5	Fan failure	Contact the after-sales for treatment. The system need to reset by manual to eliminate error codes.
E0	Outlet temperature sensor error	Check whether the outlet water temperature sensor is damaged. If so, replace the part and system can recover by itself.
F3	Water flow over the maximum value	When water flow less than 22L/min, system can recover by itself.
C4	Exhaust Blockage	Check whether the exhaust pipe is blocked. Clean up the blockage at the air inlet and exhaust outlet of the pipe. And then system should be reset by manual to eliminate error codes.
E4	Over-temperature protection	System can recover by manual to eliminate error codes.
F2	Inlet temperature sensor defective	Check whether the inlet water temperature sensor is damaged. If so, replace the part and system can recover by itself.
E3	Thermostat error	System can recover by manual to eliminate error codes.
C0	Ignition failure	Check whether there is gas in the gas pipe, or contact the after-sales department to check whether the ignition needle is damaged .The system need to reset by manual to eliminate error codes.
E6	Gas valve connection error	Contact the after-sales service personnel to check whether the connecting wire of the valve is wrongly connected. The system need to reset by manual to eliminate error codes.
E2	Wrong flame signal	Contact after-sales personnel to check whether the flame feedback needle is normal. The system needs to reset by manual to eliminate error codes.
C1	Gas valve leakage	Contact the after-sales service personnel to check the valve for leakage. The system needs to reset by manual to eliminate error codes.
E1	No flame signal	Contact after-sales personnel to check whether the flame feedback needle is normal. The system needs to reset by manual to eliminate error codes.

Manual reset steps:

Closing the water inlet or pressing ON/OFF button can eliminate the fault.

- Common failures and treatment.

Phenomena Causes		Treatment									
		Flameout during operation.	The unit will not ignite after starting	Deflagration.	Yellow flame accompanied by black fume.	Abnormal flame accompanied by abnormal odors	Abnormal sounds during ignition.	The water is still not hot even at the position of high temperature.	The water is too hot at the position of low temperature.	The flame goes out when the unit is set to the "Winter" position	The fire does not die out after the heater is turned off.
The gas valve is not opened.		●									Fully open the gas valve or replace with a new gas vessel
The gas valve is half opened.						●					Fully open the gas valve
There is air filled in the gas pipes.		●									Open and close the water outlet valve continuously for several times till the ignition successes.
Inappropriate gas pressure	High	●	●			●		●			Ask the maintenance personnel to check the gas pressure regulation valve.
	Low	●					●				
Freeze		●									Contact with the maintenance personnel

Inadequate hydraulic pressure of inlet	●	●						●	●	Ask the maintenance personnel to check hydraulic pressure
The burner is blocked.			●	●	●					Contact with the maintenance personnel.
The heat exchanger is blocked.	●			●	●					Contact with the maintenance personnel.
Failures of water flow sensor	●	●								Contact with the maintenance personnel.
Failures of pulse igniter	●	●								Contact with the maintenance personnel
Drop-off of internal wires	●	●								Contact with the maintenance personnel to connect the loosed or dropped wires correctly
Failures of fan	●	●								Contact with the maintenance personnel.
Failures of electromagnetic valve	●	●							●	Contact with the maintenance personnel.
Failures of feedback electrode	●									Contact with the maintenance personnel
Abnormal discharge distance or discharge position			●							Adjust the ignition pin, and contact with the maintenance personnel.
The power is switched off, power failure	●	●								Switch on the power
The master cold water valve is not opened.		●								Fully open the master water inlet valve.
Incorrect adjustment method of water temperature							●	●		Refer to the adjustment procedure for winter-summer fresh air.
Inadequate supply of fresh air			●	●	●					Improve the ventilation immediately to guarantee adequate fresh air supply.
Blocked fume duct	●	●								Reuse after clearing away foreign objects from the flue.

If other failures are encountered, stop use of the water heater immediately, and notify the professional maintenance department for repair. The users shall not remove or repair the water heaters without prior permission, otherwise an accident might occur.



WARNING

No use of water heaters with any failures.

DISPOSAL OF PACKAGING AND



Dispose of packaging in an environmentally-friendly manner. This appliance is labelled in accordance with European Directive 2012/19/EU concerning used electrical and electronic appliances (waste electrical and electronic equipment - WEEE). The guideline determines the framework for the return and recycling of used appliances as applicable throughout to the EU.

PACKAGE INFORMATION: Packaging materials of the product are manufactured from recyclable materials in accordance with our National Environment Regulations. Do not dispose of the packaging materials together with the domestic or other wastes. Take them to the packaging material collection points designated by the local authorities.

7. GUIDELINES FOR GAS SOURCE CONVERSION

- Remove the screws (4 pieces) and take out the lower shell.

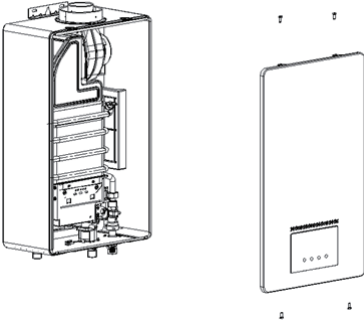

- Remove the proportional valve intake connector as shown in the diagram

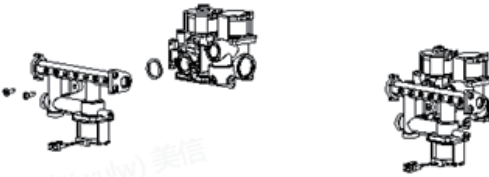
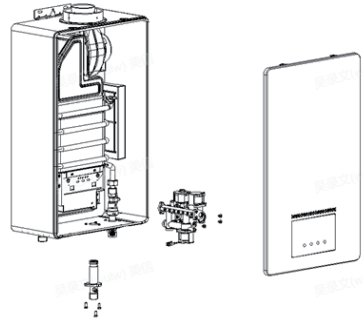

- Remove the air distribution rod from the proportional valve and replace it with the corresponding spare air distribution rod for the gas source. Pay attention to installing the sealing ring and tightening the screw.

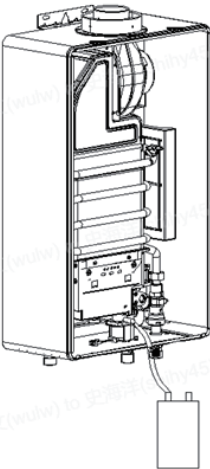

- Install the proportional valve and intake joint, tighten the screws, and conduct a gas path airtightness test on the entire machine. After passing the inspection, loosen the screws on the gas distribution rod, connect the micro pressure gauge, cover the upper shell, and adjust and calibrate the parameters of the corresponding gas source according to after-sales requirements. After calibration is completed, open the surface shell, remove the micro pressure gauge, tighten the screws, and install the surface shell

The product is subject to change without notice.
Please keep this manual properly.