

# ESSENCE

VSG-Eindeckung

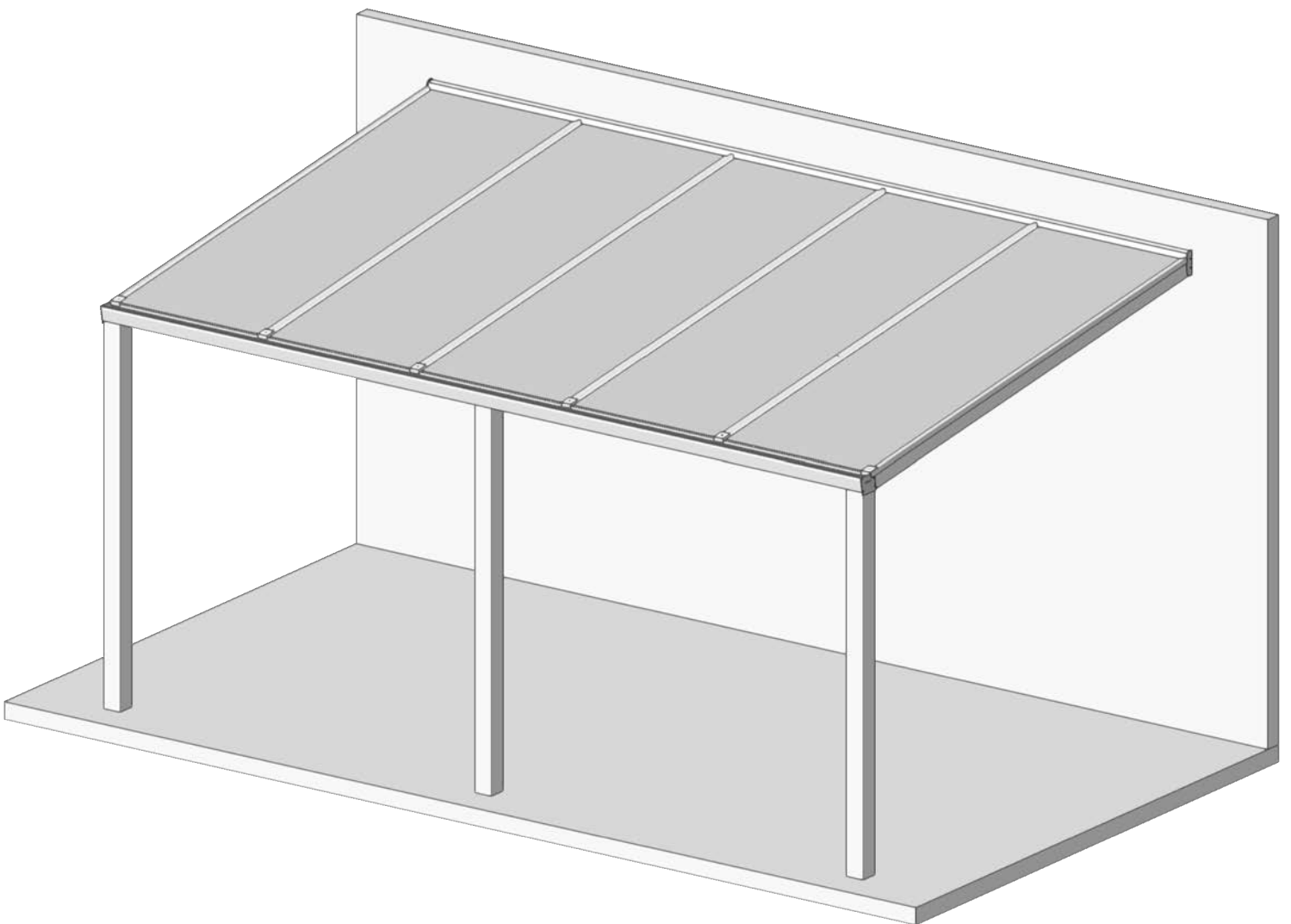

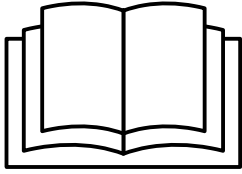

## NEDERLANDS

Belangrijke informatie !  
Goed lezen !  
Bewaar deze informatie voor toekomstig gebruik

### Handleiding voor de eindgebruiker en de monteur:

Geachte klant,

Bedankt voor de aanschaf van een Verasol product. Deze handleiding bevat alle benodigde informatie om snel vertrouwd te raken met het product. Wij verzoeken u vriendelijk om deze informatie zorgvuldig door te nemen alvorens met het product te gaan werken.



Deze handleiding is bedoeld voor de eindgebruiker en monteurs. Wij adviseren om de montage van deze constructie door (minimaal) 2 personen uit te voeren.

De montage van het product wordt omschreven in 2 hoofdstukken:

- 1: Voorbereiding voor montage
- 2: Montage

**Dit is de originele handleiding, bewaar deze handleiding goed!**

### Beschrijving product:

De veranda / carport mag uitsluitend worden gebruikt om een terras / oprit te overkappen, elk ander gebruik dan hier omschreven bedoeld gebruik wordt gezien als onbedoeld gebruik. De fabrikant kan niet verantwoordelijk worden gesteld voor eventuele (gevolg) schade veroorzaakt door onbedoeld, verkeerd of onverstandig gebruik.

### Gebruikte symbolen:



Dit symbool betekent dat het betreffende product niet is meegeleverd en u het zelf dient aan te schaffen.



Dit symbool betekent dat u de meegeleverde schroef dient te gebruiken. Het soort en het aantal schroeven staat onder de afbeelding.



Bevestigingsmaterialen die niet zijn meegeleverd dient u zelf aan te schaffen omdat de bevestiging per situatie verschillend is en afhankelijk is van de ondergrond of bouwkundige constructie waaraan bevestigd moet worden. Raadpleeg hiervoor altijd een bouwmaterialen vakhandel welke bevestigingsmiddelen in uw situatie gebruikt moeten worden en gebruik alleen RVS bevestigingsmiddelen.

### Omgevingsinvloeden:

Dit product is bedoeld voor buitengebruik en mag nat worden. Een veranda is een ongeïsoleerde constructie die bedoeld is om het woongenot buiten te verruimen en deze mag niet als geïsoleerde woninguitbreiding beschouwd worden. Bij bepaalde weersomstandigheden kan er condensvorming ontstaan in geringe of meerdere mate, dit is een vrijwel niet invloedbaar natuurlijk proces wat niet kan worden voorkomen en is van tijdelijke aard. Condensvorming kan vaak verminderd worden met behulp van ventilatie.

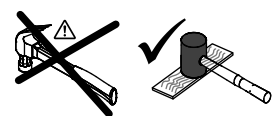
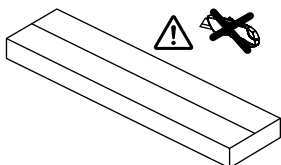

### Open de verpakking met beleid !

#### Controleer de inhoud op aantallen en transportschade !

Maak in het geval van transportschade duidelijke foto's en neem contact op met uw verkooppunt !



Denk aan uw veiligheid, loop NIET over de Dakplaten !



Denk aan uw veiligheid, gebruik persoonlijke beschermingsmiddelen zoals veiligheidsschoenen, handschoenen en gezichtsbescherming en hoofdbescherming.



**Bij hevige sneeuwval dient deze, wanneer het meer dan 25 cm is zoveel mogelijk te worden verwijderd !**

### Voorzorgsmaatregelen en veiligheidsinstructies:

#### Waarschuwing!

- Indien uw product verlichting of verwarming bevat dan mag de elektrische installatie alleen uitgevoerd worden door een erkend installateur.
- De verantwoordelijkheid voor het correct laten monteren en gebruiken van het product ligt bij de eindgebruiker. Onjuiste montage of onjuist gebruik kan leiden tot beschadiging van, of een defect aan het product. De garantie vervalt wanneer het product en/of de elektronische onderdelen beschadigd raken door onjuiste montage of gebruik.
- Neem de lokale wet- en regelgeving in acht tijdens het monteren en/of gebruik van het product.

#### Let op!

- Alle schroeven dienen voorzichtig met een draaimoment van 1.0 Nm bevestigd te worden. Let op dat u de schroeven met beleid vastdraait, u schroeft in aluminium, dit is zacht materiaal en schroeven draaien snel "dol".
- Controleer tijdens het uitpakken of alle onderdelen in de verpakking aanwezig zijn en controleer alle onderdelen op eventuele beschadigingen.
- Neem contact op met uw verkooppunt indien een onderdeel ontbreekt of beschadigd is, maak indien mogelijk foto's van eventueel beschadigde verpakkingen en onderdelen.

#### Onderhoud, milieu en afdanken:

- Reinig het product bij vervuiling of maximaal om de 6 maanden om een langere levensduur van het product te bewerkstelligen.



Het symbool op het materiaal, de accessoires of verpakking geeft aan dat dit product niet als huishoudelijk afval mag worden behandeld. Voer het apparaat af via een verzamelpunt voor de recycling van afgedankte elektrische apparatuur binnen de EU en in andere Europese landen die aparte verzamelssystemen voor gebruikte elektrische en elektronische apparatuur kennen. Door het apparaat op de juiste manier af te voeren helpt u mogelijke gevaren voor het milieu en de volksgezondheid te voorkomen die anders door verkeerde behandeling van het afgedankte apparaat zouden worden veroorzaakt. Het recyclen van materialen draagt bij aan het behoud van natuurlijke rijkdommen, voer daarom uw oude elektrische en elektronische apparatuur niet af via het huishoudelijke afval.





## DEUTSCH

Wichtige information !  
Sorgfältig lesen !  
Diese Anleitung gut aufbewahren !

### Anleitung für Endverbraucher und Monteure:

Sehr geehrter Kunde!

Wir danken Ihnen für den Kauf dieser Verasol produkt. Diese Anleitung enthält alle wichtigen Informationen, damit Sie schnell mit dem Produkt vertraut werden. Wir bitten Sie diese Informationen sorgfältig durchzulesen bevor Sie mit der Montage beginnen.



Diese Anleitung ist für Endverbraucher und Monteure bestimmt. Wir empfehlen, die Montage dieser Konstruktion von (mindestens) zwei Personen durchführen zu lassen.

Die Montage des Produktes wird in zwei Kapiteln beschrieben:  
1: Vorbereitung der Montage  
2: Montage

### Beschreibung des Produktes:

Die Überdachung darf ausschließlich zur Überdachung einer Terrasse verwendet werden. Jede andere als die hier beschriebene Verwendung gilt als zweckwidrige Verwendung. Der Hersteller haftet nicht für eventuelle Schäden oder Folgeschäden, die durch zweckwidrige, falsche oder unsachgemäße Verwendung entstehen.

### Verwendete Symbole:



Dieses Symbol bedeutet, dass das betreffende Produkt nicht im Lieferumfang enthalten ist und selbst besorgt werden muss.



Dieses Symbol bedeutet, dass Sie die mitgelieferte Schrauben verwenden müssen. Art und Anzahl der Schrauben sind unter der Abbildung angegeben.



 Befestigungsmaterialien, die nicht im Lieferumfang enthalten sind, müssen Sie selbst besorgen, da die Befestigung je nach Situation unterschiedlich ist und vom Untergrund oder der Baukonstruktion abhängt, an der die Befestigung angebracht werden soll. Erkundigen Sie sich in einem Baufachhandel, welche Befestigungsmittel in Ihrer Situation verwendet werden sollten, und verwenden Sie nur Befestigungsmittel aus Edelstahl.

### Witterungseinflüsse:

Dieses Produkt ist für die Verwendung im Freien bestimmt und darf nass werden.

Eine Veranda ist eine nicht isolierte Konstruktion, die den Genuss des Lebens im Freien verbessern soll und nicht als isolierte Erweiterung des Hauses betrachtet werden sollte.

Unter bestimmten Wetterbedingungen kann sich in geringem oder größerem Umfang Kondenswasser bilden. Dies ist ein natürlicher Prozess, der nicht verhindert werden kann und vorübergehender Natur ist.

Kondensation kann oft mit Hilfe von Belüftung reduziert werden.

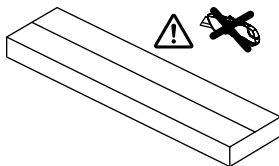

**Öffnen Sie die Verpackung vorsichtig !**

**Prüfen Sie den Inhalt auf Vollständigkeit und Transportschäden !**

Machen Sie bei Transportschäden deutliche Fotos und setzen Sie sich mit Ihrem Händler in Verbindung !

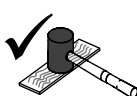

Denken Sie an Ihre Sicherheit und betreten Sie die Dacheindeckung nicht !



Denken Sie an Ihre Sicherheit, verwenden Sie persönliche Schutzausrüstung wie Sicherheitsschuhe, Handschuhe und Gesichtsschutz u Kopfschutz.



**Bei starkem Schneefall, (mehr als 25 cm) ist, sollte dieser so gut wie möglich entfernt werden !**

### Schutzmaßnahmen und Sicherheitsanweisungen:

#### Warnung!

- Wenn Ihre produkt über eine Beleuchtung oder Beheizung verfügt, dürfen die Elektroinstallationen nur von einem fachkundigen Installateur vorgenommen werden.
- Die einzelnen Schritte dieser Montageanleitung sind einzuhalten. Eine falsche Montage oder Nutzung kann zu Beschädigungen am Produkt und zum Erlöschen der Garantie führen. Wir empfehlen Ihnen die Montage von fachkundigen Personen durchführen zu lassen bzw. prüfen zu lassen.
- Halten Sie sich bei der Montage und Nutzung des Produktes an die lokalen Gesetze und Vorschriften.

#### Achtung!

- Alle Schrauben müssen vorsichtig, mit einem Drehmoment vom 1,0 Nm angezogen werden. Achten Sie darauf, dass Sie die Schrauben mit Gefühl anziehen. Sie schrauben in Aluminium, einem weichen Material, in dem Schrauben schnell durchdrehen können.
- Kontrollieren Sie beim Auspacken, ob alle Teile in der Verpackung sind, und prüfen Sie alle Teile auf eventuelle Beschädigungen.
- Falls ein Teil fehlt oder beschädigt ist, setzen Sie sich mit Ihrem Lieferanten in Verbindung. Wenn möglich, machen Sie Fotos von eventuell beschädigten Verpackungen und Teilen.

#### Pflege, Umwelt und Entsorgung:

- Reinigen Sie das Produkt bei Verschmutzungen, mindestens aber alle sechs Monate, um eine längere Lebensdauer des Produktes zu erreichen.



Dieses Symbol auf dem Material, dem Zubehör oder der Verpackung gibt an, dass dieses Produkt nicht über den Hausmüll entsorgt werden darf. Entsorgen Sie das Produkt innerhalb der EU und in anderen europäischen Ländern, die über entsprechende Einrichtungen verfügen, über eine Recyclingsammelstelle für ausgediente Elektrogeräte. Durch eine ordnungsgemäße Entsorgung des Gerätes helfen Sie mit, Gefährdungen der Umwelt und Gesundheit der Bevölkerung zu vermeiden, die von einer nicht ordnungsgemäßen Entsorgung des Gerätes ausgehen. Das Recycling von Materialien trägt zum Erhalt der Natur bei. Entsorgen Sie Ihre Elektrogeräte deshalb nicht über den Hausmüll.





## ENGLISH

Important information !  
Read carefully !  
Keep this information for further reference

### Manual for the end user and the installer:

Dear customer,

Thank you for purchasing one of our products. This manual provides all the necessary information to quickly become familiar with the product. We kindly ask you to read this information carefully before working with the product.



This manual is intended for the end user and installers. We recommend that the assembly of this construction be carried out by (at least) 2 persons.

The assembly of the product is described in 2 chapters:

- 1: Preparation for assembly
- 2: Assembly

**This is the original manual, look after it!**

### Product Description:

The veranda may only be used to cover a terrace. Any use, other than defined here, is seen as unintended use. The manufacturer cannot be held responsible for any (consequential) damage caused by unintended, improper or unwise use.

### Symbols used:



This symbol means that the product is not included and you have to purchase it yourself.



This symbol means that you must use the supplied screw. The type and number of screws are shown beneath the image.



Mounting materials that are not included must be purchased separately because each situation requires different fixings and depends on the substrate or construction to which it needs to be affixed. Always seek advice from a specialist building supplier about what is required in your particular situation and only use stainless steel fixings.

### Environmental conditions:

This product is intended for outdoor use and may get wet. A veranda is an uninsulated construction that is intended to enhance the enjoyment of living outdoors and should not be regarded as an insulated extension of the home. Under certain weather conditions, condensation may form to a small or greater extent, this is a natural process that cannot be prevented and is of a temporary nature. Condensation can often be reduced with the help of ventilation.

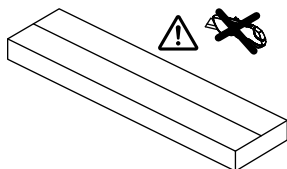

### Open the packaging with caution ! Check for missing or damaged contents !

In the case of shipping damage, make photos and contact your dealer !

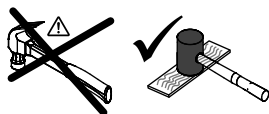

Think about your safety, do not walk on the roofing sheets !



Think of your safety, use personal protective equipment such as safety shoes, gloves and face protection and head protection. !

### Precautions and Safety Instructions:

#### Warning!

- If your product contains lighting or heating, the electrical installation may only be carried out by a qualified installer.
- The end user is responsible for the correct installation and use of the product. Improper assembly or improper use may cause damage to, or a defect in, the product. The warranty is void if the product and/or the electronic components are damaged due to improper assembly or use.
- Observe local laws and regulations when assembling and/or using the product.

#### Please note!

- All screws should be carefully tightened with a torque of 1.0 Nm. Make sure you tighten the screws with caution, when screwing into soft materials like aluminium, screws can easily get "stripped".
- When unpacking, check that all parts are present and check all components for possible damage.
- Contact your supplier if any parts are missing or damaged, if possible, take photographs of any damaged packaging and parts.

#### Maintenance, environment and disposal:

- Clean the product when dirty or at least every 6 months to ensure a longer product life.



The symbol on the material, the accessories or packaging indicates that this product may not be treated as household waste. Dispose of the device through a collection point for recycling waste electrical equipment within the EU and in other European countries that have separate collection systems for used electrical and electronic equipment. Properly disposing of the device helps you to prevent possible environmental and public health hazards that would otherwise be caused by improper handling of the waste device. Recycling materials helps to conserve natural resources, so do not dispose of your old electrical and electronic equipment through household waste.



In the case of heavy snowfall, when it is more than 25 cm, it should be removed as much as possible !



## FRANÇAIS

Information importante !  
A lire attentivement.  
Conserver ces informations pour un usage ultérieur.

### Notice pour Client final et Installateur:

Cher client,

Nous vous remercions de votre achat. Ce manuel contient toutes les informations nécessaires pour rapidement vous familiariser avec la pergola que vous venez d'acquérir.

Nous vous prions de lire attentivement ces informations avant de commencer le montage de votre produit.



Ce manuel est destiné à l'utilisateur final et aux monteurs. Nous recommandons que l'installation de cette construction soit réalisée au minimum par 2 personnes.

La présente notice décrit le montage en 2 parties :

1. Préparation au montage
2. Montage

### Description Produit:

La pergola trouve une application de couverture de terrasse ou patio. Toute autre fonction donnée au produit est considérée comme fortuite. Le fabricant ne peut être tenu responsable de dégâts occasionnés dans le cas d'une utilisation incorrecte ou détournée. Le montage du produit doit-être réalisé suivant les règles de l'art.

### Symboles utilisés:



Ce symbole signifie que l'article n'est pas fourni et reste à la charge du client.



Ce symbole précise le type de vis à utiliser. Le type et la quantité sont précisés en dessous du symbole.



Les pièces de fixation au sol et murales ne sont pas fournies et demeurent à la charge du client.

### ExSchémation aux éléments extérieurs

Le produit est résistant aux intempéries.

Une Pergola est une construction non isolée qui vise à améliorer le plaisir de vivre à l'extérieur et ne doit pas être considérée comme une extension isolée de la maison.

Dans certaines conditions météorologiques, de la condensation peut se former dans une plus ou moins grande mesure, c'est un processus naturel qui ne peut être évité et qui est de nature temporaire.

La condensation peut souvent être réduite à l'aide de la ventilation.

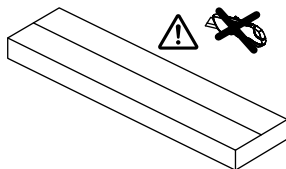

### Ouvrir l'emballage avec précaution !

Contrôler le contenu et émettre des réserves en cas de pièces manquantes ou détériorées auprès de votre revendeur.

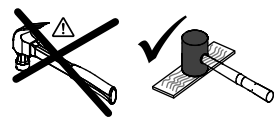

Pour votre sécurité, ne pas marcher sur la toiture !



Pensez à votre sécurité, utilisez des équipements de protection individuels tels que des chaussures de sécurité, des gants et une protection du visage et de la tête.

### Consignes de sécurité Attention !

- Dans l'hypothèse où votre pergola est équipée d'un éclairage, l'installation électrique doit-être réalisée par un professionnel certifié.
- Le client demeure responsable du montage et de l'utilisation corrects du produit. Un montage ou une utilisation incorrecte peut endommager de façon irréversible le produit. La garantie sera inopérante si le produit et/ou les composants électroniques ont été endommagés par un montage ou une utilisation incorrecte
- Toujours prendre connaissance des règles d'usage locales et de la législation en vigueur lors du montage ou de l'utilisation du produit.

### Important !

- Toutes les vis doivent-être serrées à un couple de serrage de 1.0 Nm.
- Merci de contacter votre revendeur si des pièces venaient à manquer ou seraient détériorés.

### Entretien, environnement recyclage:

- Nettoyez le produit chaque semestre pour assurer une bonne durée de vie de votre produit (eà l'eau savonneuse avec une éponge et/ou une brosse douce).



Ce symbole indique que le produit ou l'emballage ne doit pas être traité comme un déchet domestique. Déchetez-le en centre de recyclage apte de gérer les appareils électriques et électroniques selon les dispositions légales EU et des autres pays européens. En recyclant ces appareils, vous contribuez à protéger l'environnement et à lutter contre les risques à l'encontre de la santé publique.

Recycler les matériels contribue à la conservation des ressources naturelles de la planète.



En cas de fortes chutes de neige, lorsqu'elles sont supérieures à 25 cm, elles doivent être enlevées autant que possible!

Breedte / Breite / Width / Largeur	3000mm, 4000mm, 5000mm, 6000mm, 7000mm
Diepte / Tiefe / Depth / Profondeur	2500mm, 3000mm, 3500mm, 4000mm

Alle tussenliggende maten worden geleverd met het materiaal van de eerstvolgende grotere overkapping.  
 Alle Zwischengrößen werden mit dem Material der nächstgrößeren Überdachung geliefert.  
 All intermediate sizes are supplied with the material of the next larger roof.  
 Toutes les dimensions intermédiaires sont livrées avec le matériel de la toiture immédiatement supérieure.

#	Artikelnaam Artikelbezeichnung Article description Désignation de l'article	Artikelnummer Artikelnummer Article number Numéro d'article	Dakbreedte Dachbreite Roof width Largeur de toiture	Aantal Anzahl Quantity Quantité	
1.	Gootprofiel Rinnenprofil Gutter profile Profil de gouttière	GLG0006		1x	
2.	Muurprofiel Mauerprofil Wall profile Profil mural	GLM0008		1x	
3.	Staanders Stützen Posts Poteaux	GLP0081	≤ 5000mm > 5000mm	2x 3x	
4.	Tussenliggers Mittelsparren Central rafters Chevrons centraux	GLT7604	3000mm 4000mm 5000mm 6000mm 7000mm	2x 3x 4x 5x 6x	
5.	Zijliggers Außensparren Outer rafters Chevrons extérieurs	GLZ7605		2x	
6.	Kliklijsten Klickblenden Click-on covers Caches clipsables	GLK0007	3000mm 4000mm 5000mm 6000mm 7000mm	6x 8x 10x 12x 14x	
7.	Condensprofielen Kondensprofile Condensation profiles Profils anti-condensation	VUP0013	3000mm 4000mm 5000mm 6000mm 7000mm	3x 4x 5x 6x 7x	

Lijst vervolgt op volgende pagina  
 Fortsetzung auf der nächsten Seite  
 List continues on the next page  
 Tableau continué à la page suivante

#	Artikelnaam Artikelbezeichnung Article description Désignation de l'article	Artikelnummer Artikelnummer Article number Numéro d'article	Dakbreedte Dachbreite Roof width Largeur de toiture	Aantal Anzahl Quantity Quantité	✓
8.	Plaatstoppers (in montageset) Plattenstopper (in Montageset) Plate stoppers (in mounting kit) Butées de plaque (en kit de montage)	MMA002		10x	
9.	Gootkappen Rinnenkappen Gutter caps Embouts de gouttière	GL0001		2x	
10.	Muurkappen Mauerkappen Wall caps Embouts muraux	GLMP01		2x	
11.	Dakrubber Dachgummi Roof sealing strip Bande d'étanchéité toiture	VER1062		2x per ligger 2x pro Sparren 2x per rafter 2x par chevron	
12.	Muurrubber Mauergummi Wall sealing strip Bande d'étanchéité murale	VER1024	3000mm 4000mm 5000mm 6000mm 7000mm	3100mm 4100mm 5100mm 6100mm 7100mm	
13.	Liggerrubber Sparrengummi Rafters sealing strip Bande d'étanchéité chevron	VER10251		2x per ligger 2x pro Sparren 2x per rafter 2x par chevron	
14.	Afdeklijsten Abdeckleisten Cover strips Lattes de recouvrement	TA8607	3000mm 4000mm 5000mm 6000mm 7000mm	2x 3x 4x 5x 6x	
15.	Hoeken / Verbindingshoek Winkel Brackets / Angles Équerres / Angles	ZA8606		2x	
16.	Dachglas (VSG)	VER1201 / VER1203	3000mm 4000mm 5000mm 6000mm 7000mm	4x 6x 7x 8x 10x	



Lijst vervolgt op volgende pagina  
 Fortsetzung auf der nächsten Seite  
 List continues on the next page  
 Tableau continué à la page suivante



#	Artikelnaam Artikelbezeichnung Article description Désignation de l'article	Artikelnummer Artikelnummer Article number Numéro d'article	Dakbreedte Dachbreite Roof width Largeur de toiture	Aantal Anzahl Quantity Quantité	
18.	Regenwaterafvoer Regenwassablauf Rainwater outlet Évacuation d'eau de pluie	VER1013 VER1014 VER1018		1x 1x 1x	
19.	Plaatstoppers (in montageset) Plattenstopper (im Montageset) Plate stoppers (in mounting kit) Butées de plaque (en kit de montage)	VER1049		2x	
20.	Montageset Montageset Mounting kit Kit de montage	VER1041		1x	





Alle aanvullend bestelde artikelen vindt u terug op uw orderbevestiging.  
 Alle zusätzlich bestellten Artikel finden Sie auf Ihrer Auftragsbestätigung.  
 All additionally ordered items can be found on your order confirmation.  
 Tous les articles commandés en supplément figurent sur votre confirmation de commande.

**Afbeeldingen kunnen afwijken van de werkelijkheid**

**Onderdelenlijst (1/3) etc.**

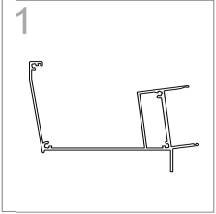
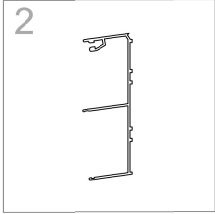
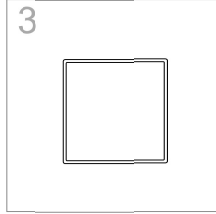
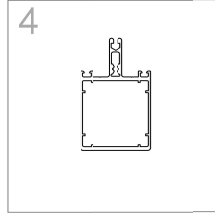
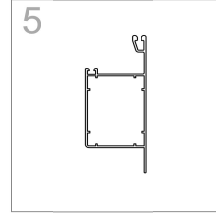
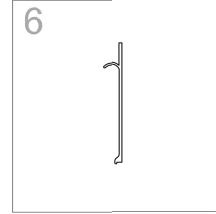
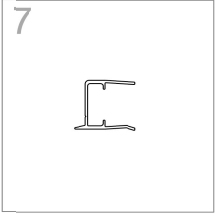
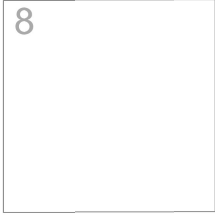
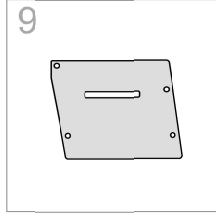
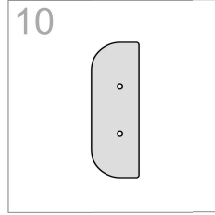
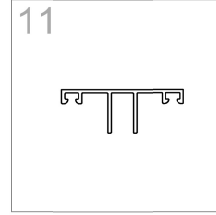
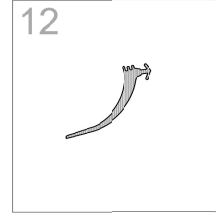
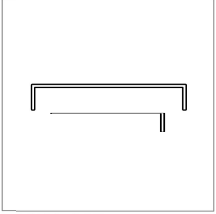
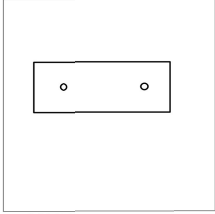
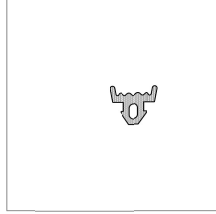
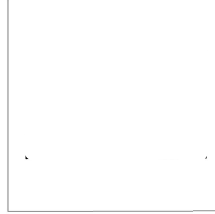

 **Overzicht profielen en onderdelen**  
 **Übersicht Profile und Teile**

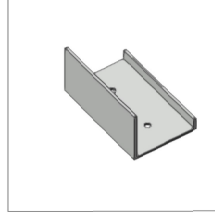
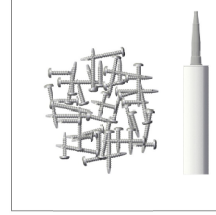
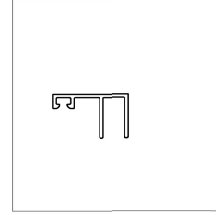
 **Overview profiles and parts**  
 **Aperçu des profils et des pièces**

					
GLG 0006	GLM 0008	GLP 0081	GLZ 7605	GLT 7604	GLK 0007
					
VUP 0013		GL 0001 GK	GLMP 01	TA 8607	VER 1024
					
MMA 003	MMA 002	VER 10251	VER 1201 / 1203		
					
VER 1013	VER 1014	VER 1018	VER 1049	VER 1041	ZA 8606

 **Optionele profielen en onderdelen**  
 **Optional Profile und Teile**

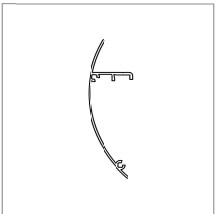
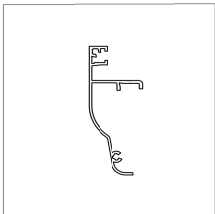
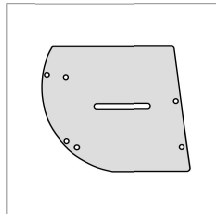
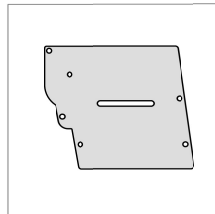
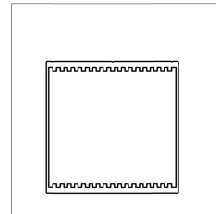
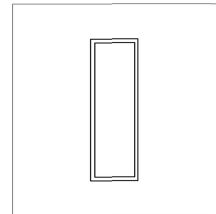
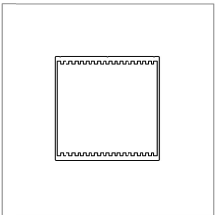
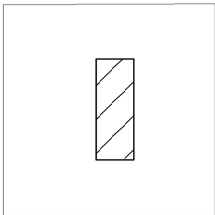
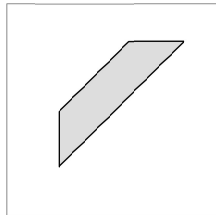
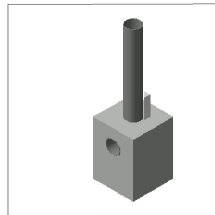
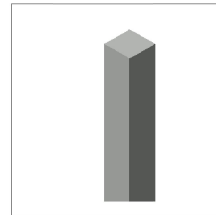
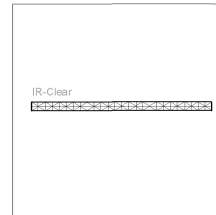
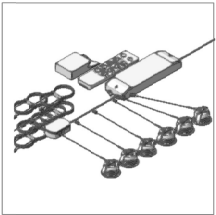
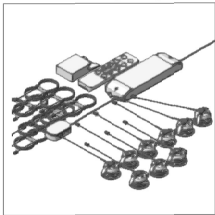
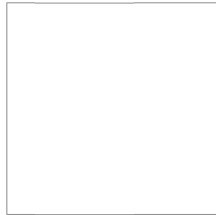
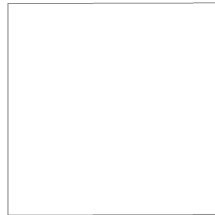
 **Optional profiles and parts**  
 **Optionnel des profils et des pièces**

					
GLGK 0002	GLGR 0003	GLGR 15103	GLGR 15104	VVK 110	VVK 50150
					
VVK 110	VVK 40/20 ( Fe )	VER 1001	VER 10271	VER 10281	VER 1207
					
LED 0001	LED 0002	LED 0003	LED 0004	Zonnedoekpakket 1	Zonnedoekpakket 2

 **Overzicht benodigde gereedschappen**  
**Übersicht Werkzeuge benötigt**

 **Overview needed tools**  
**Aperçu du outils requis**

NIET INBEGREPEN  
NICHT ENTHALTEN  
NOT INCLUDED  
NON INCLUS

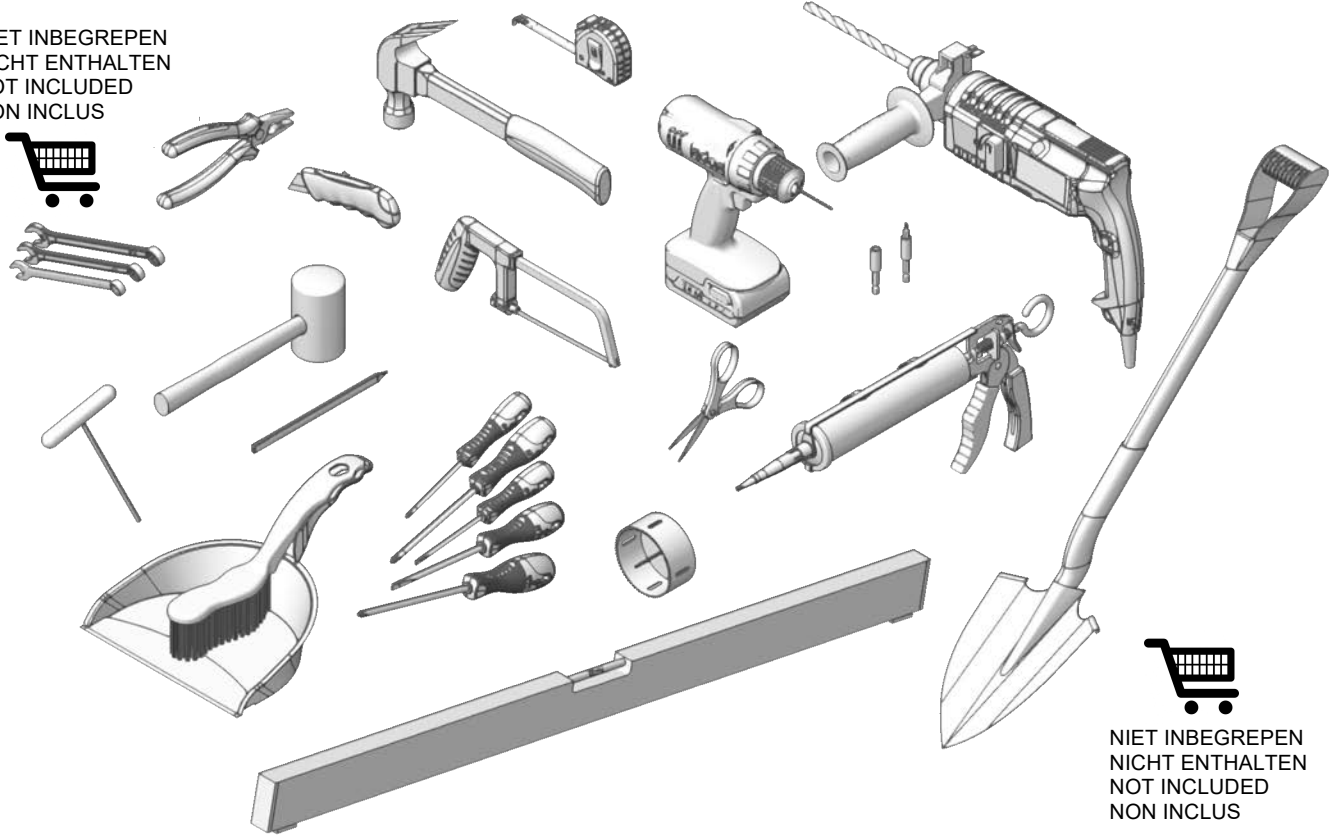

NIET INBEGREPEN  
NICHT ENTHALTEN  
NOT INCLUDED  
NON INCLUS

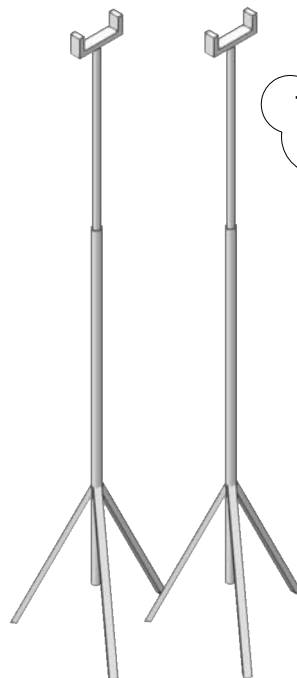
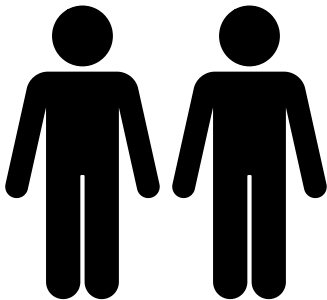

TIP !!

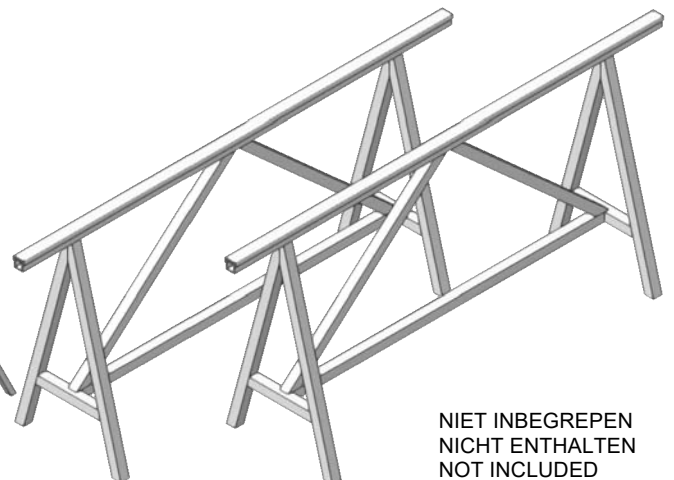

NIET INBEGREPEN  
NICHT ENTHALTEN  
NOT INCLUDED  
NON INCLUS

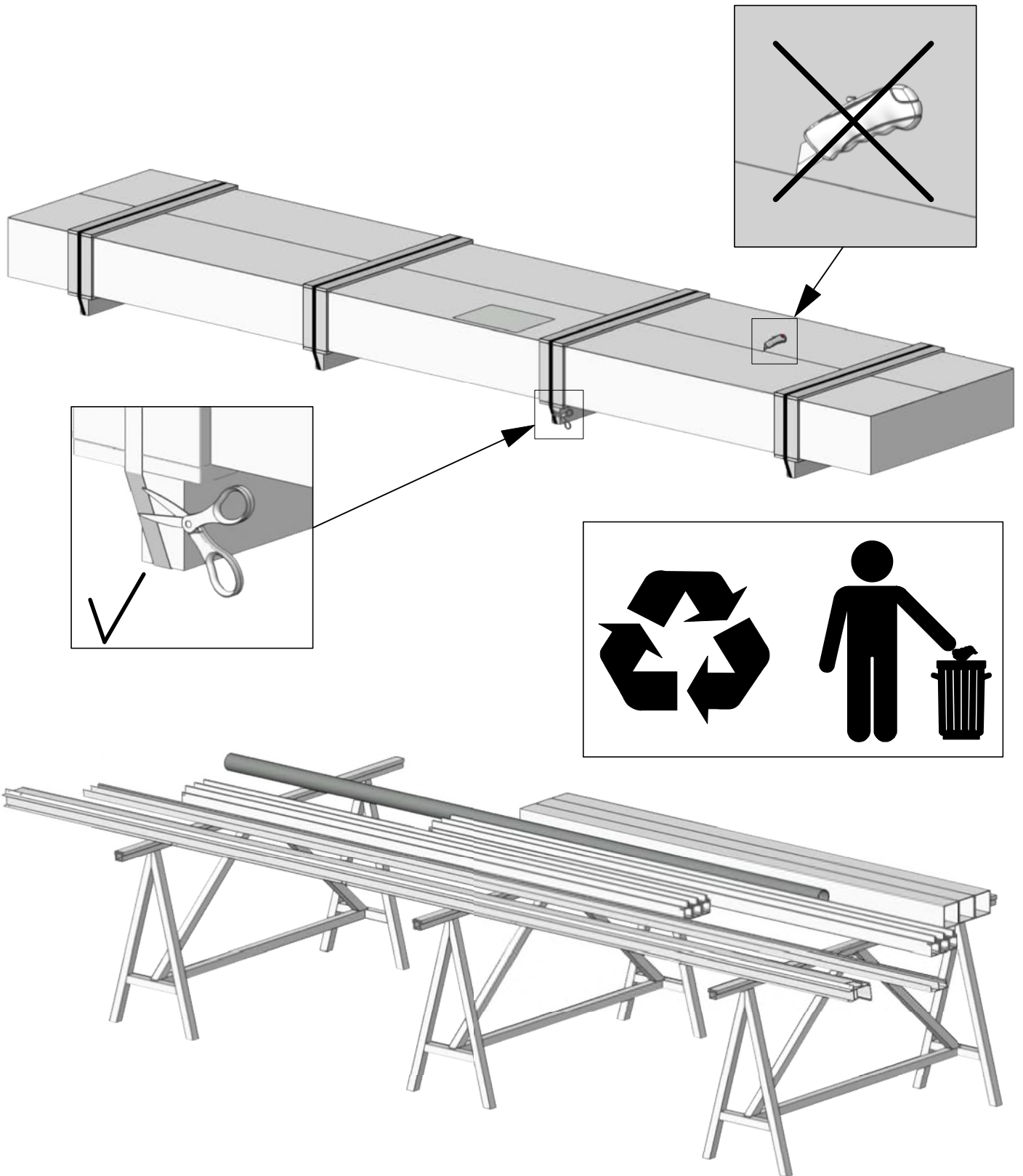

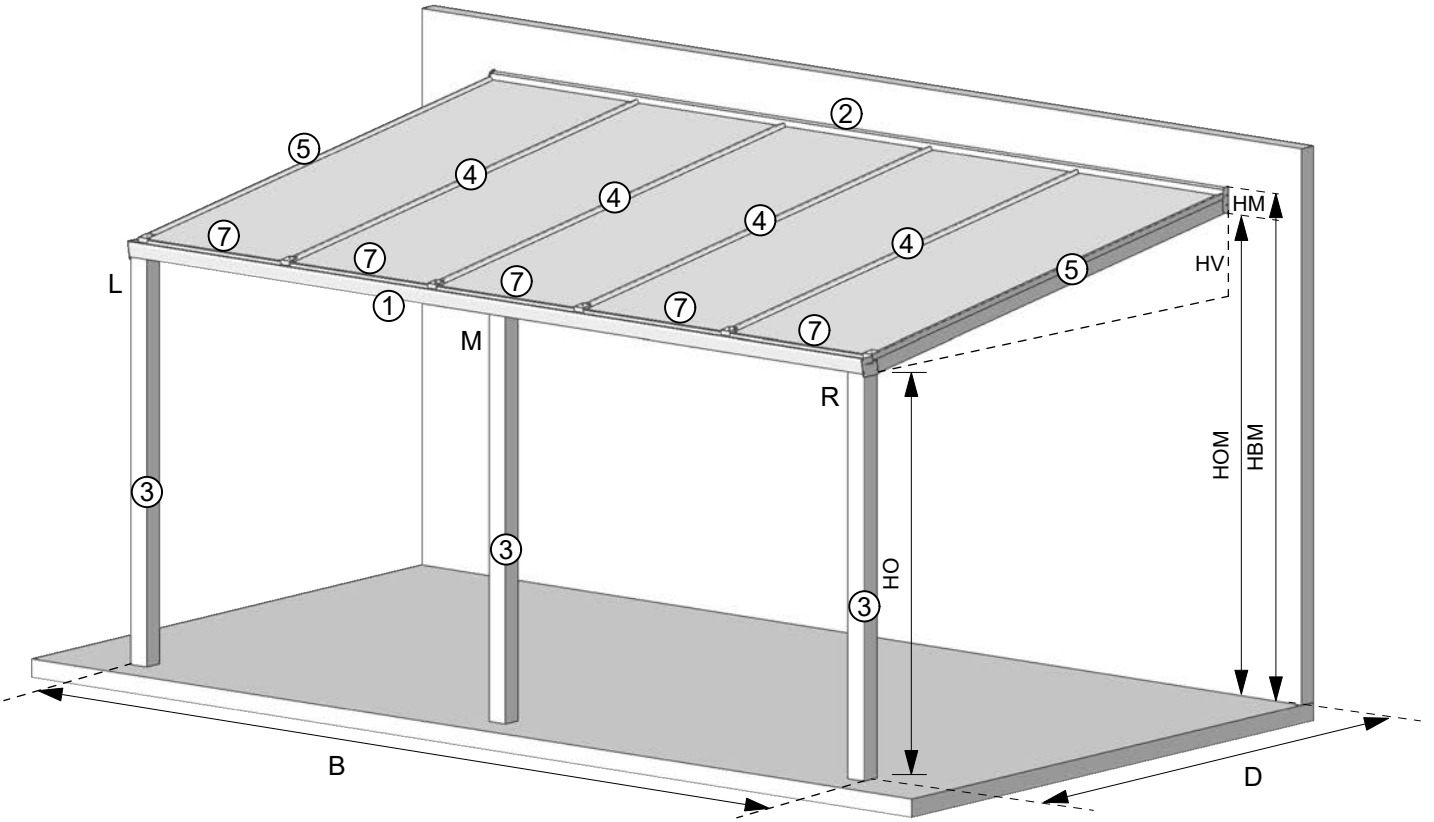

**Voorbeeld**  
**Beispiel**  
**Example** 5 x 3 mtr  
**Exemple**

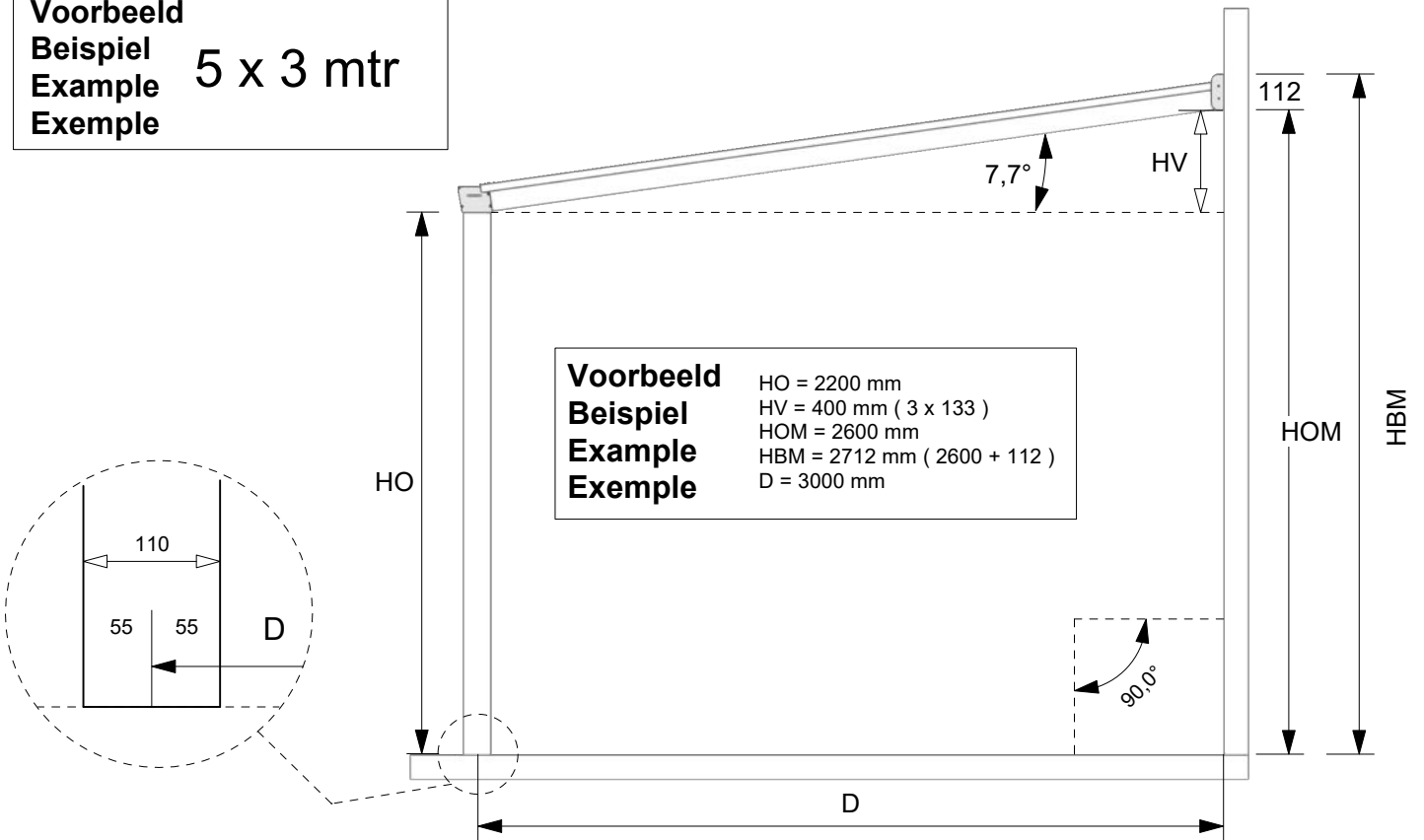

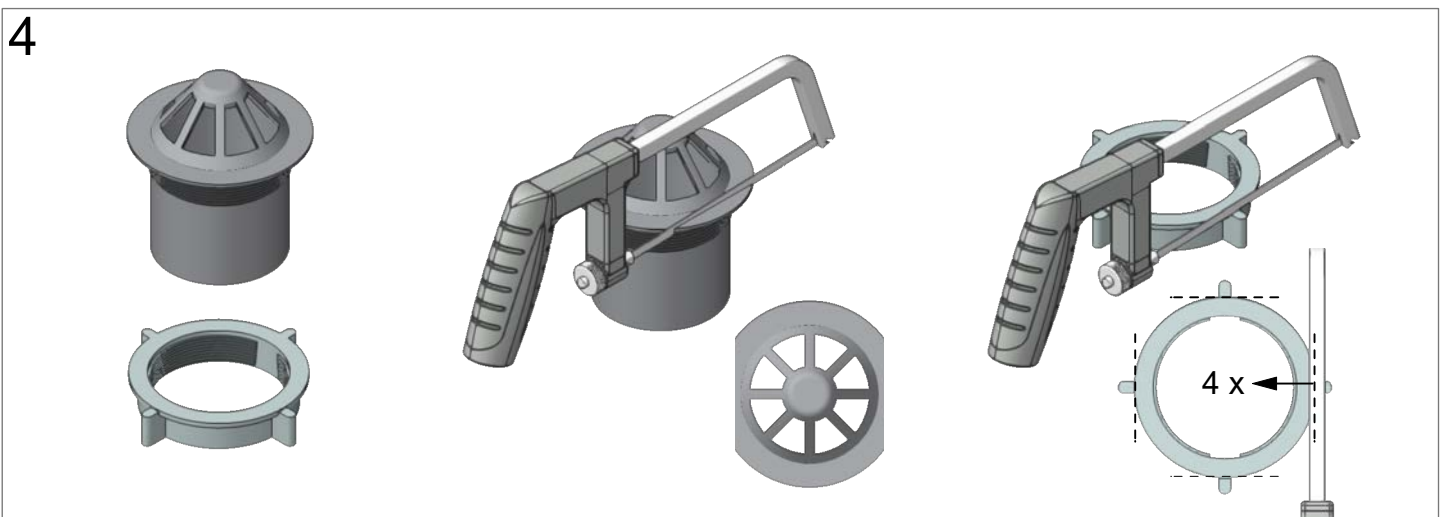
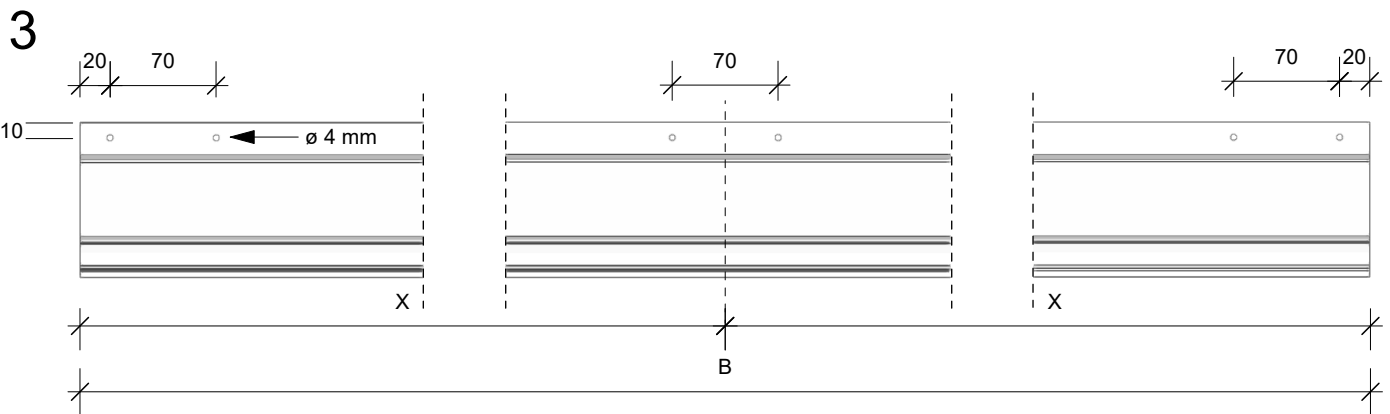
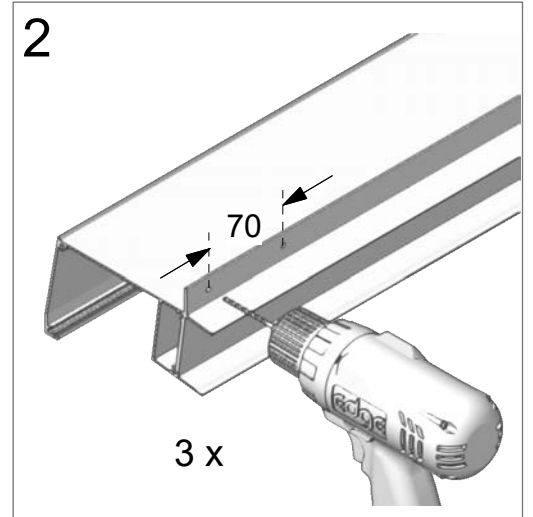
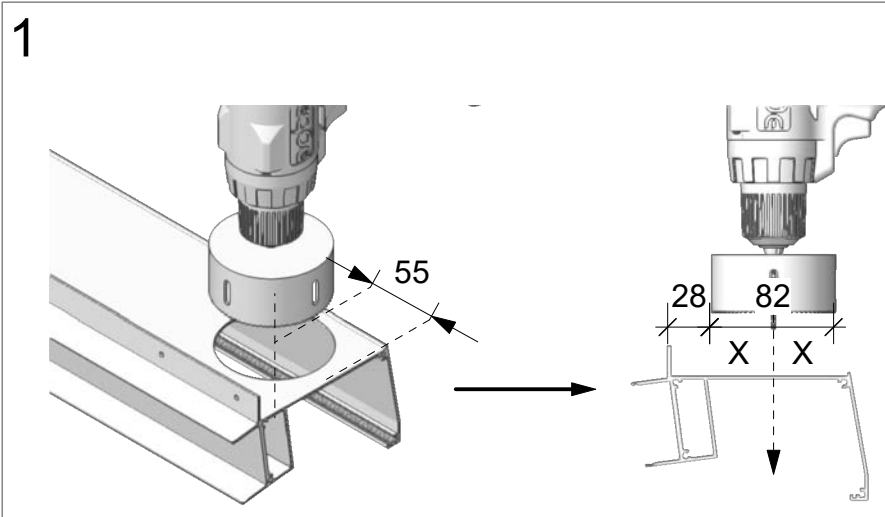
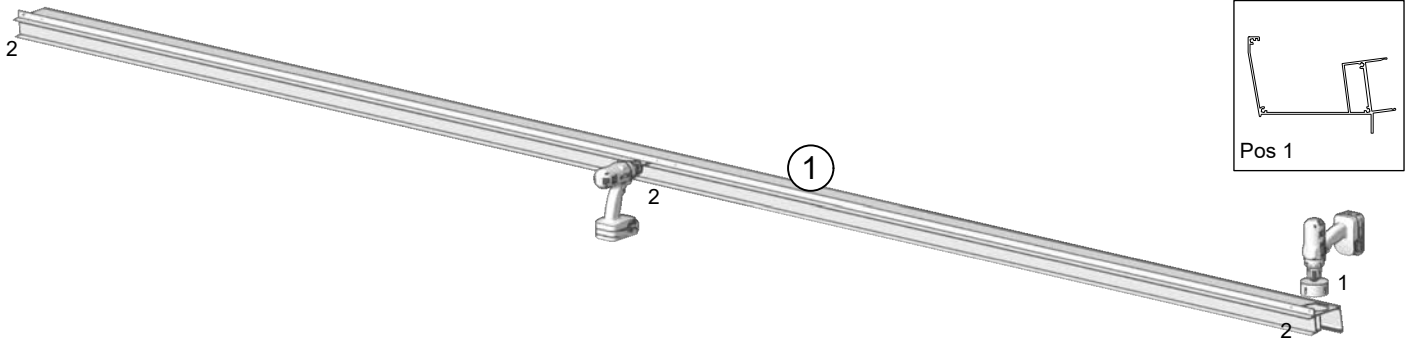

Vorbereitung Gootprofil  
 Vorbereitung Rinnenprofil

Preparation gutterprofile  
 Préparation profil de gouttière

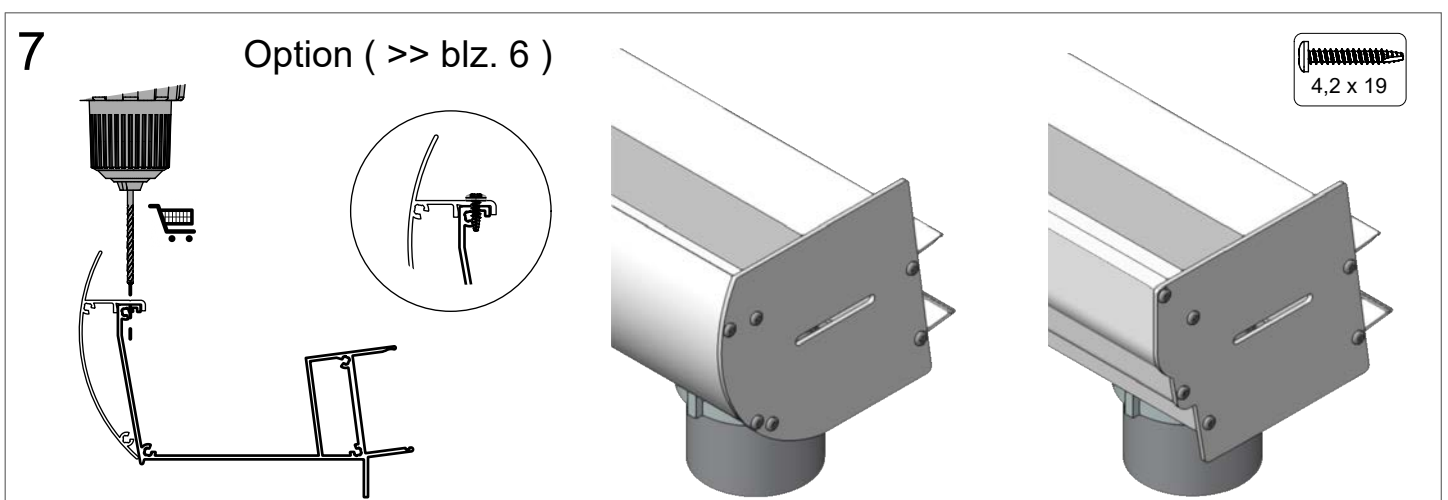
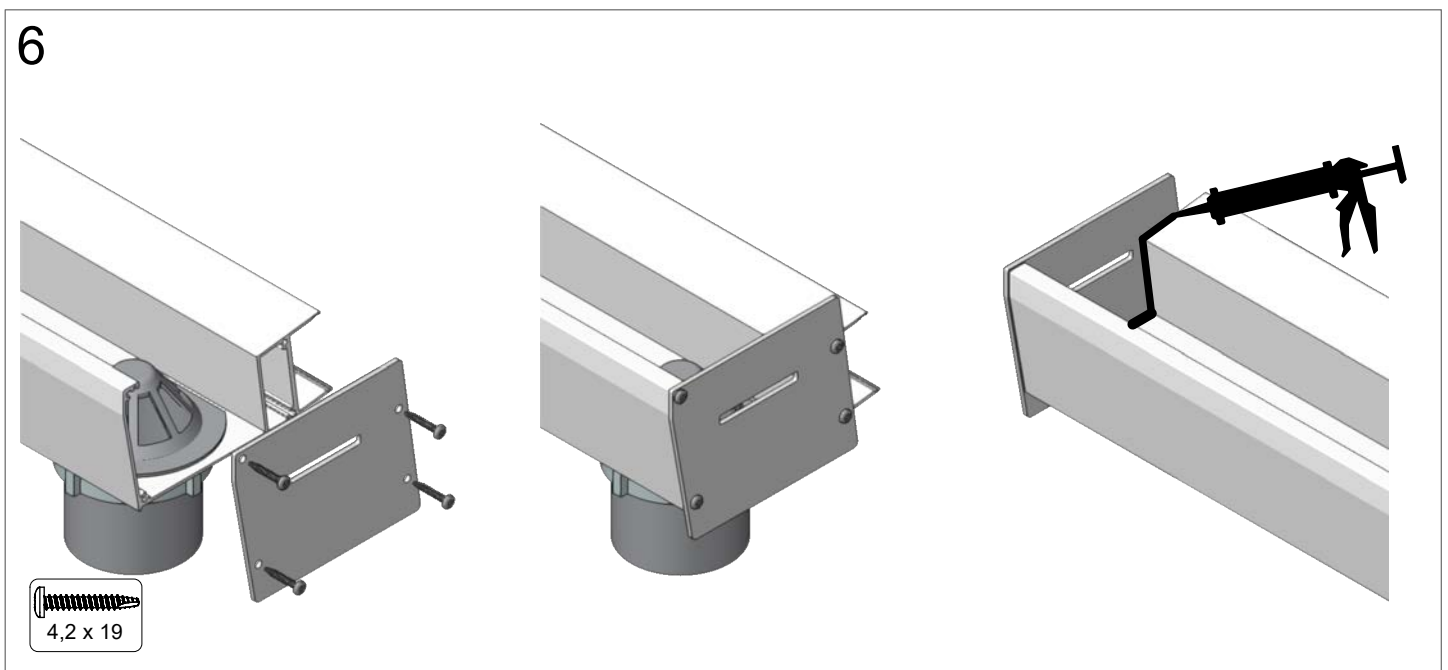
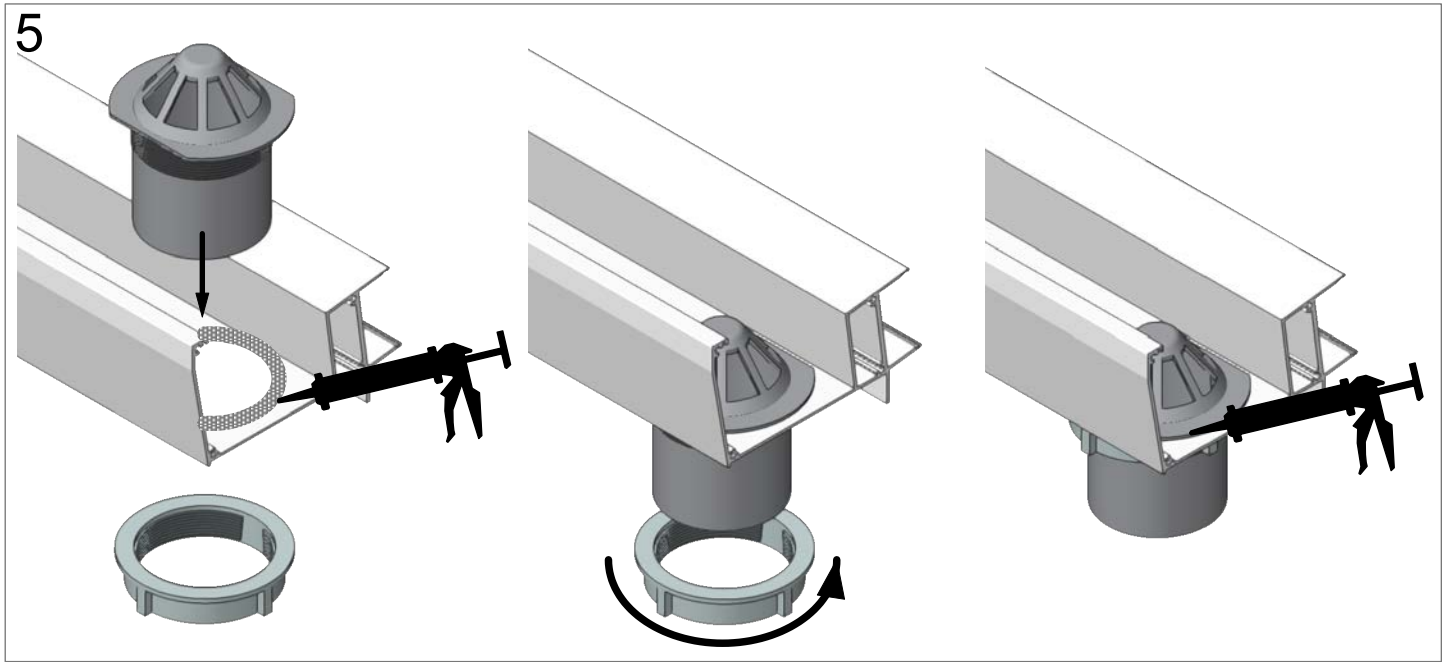

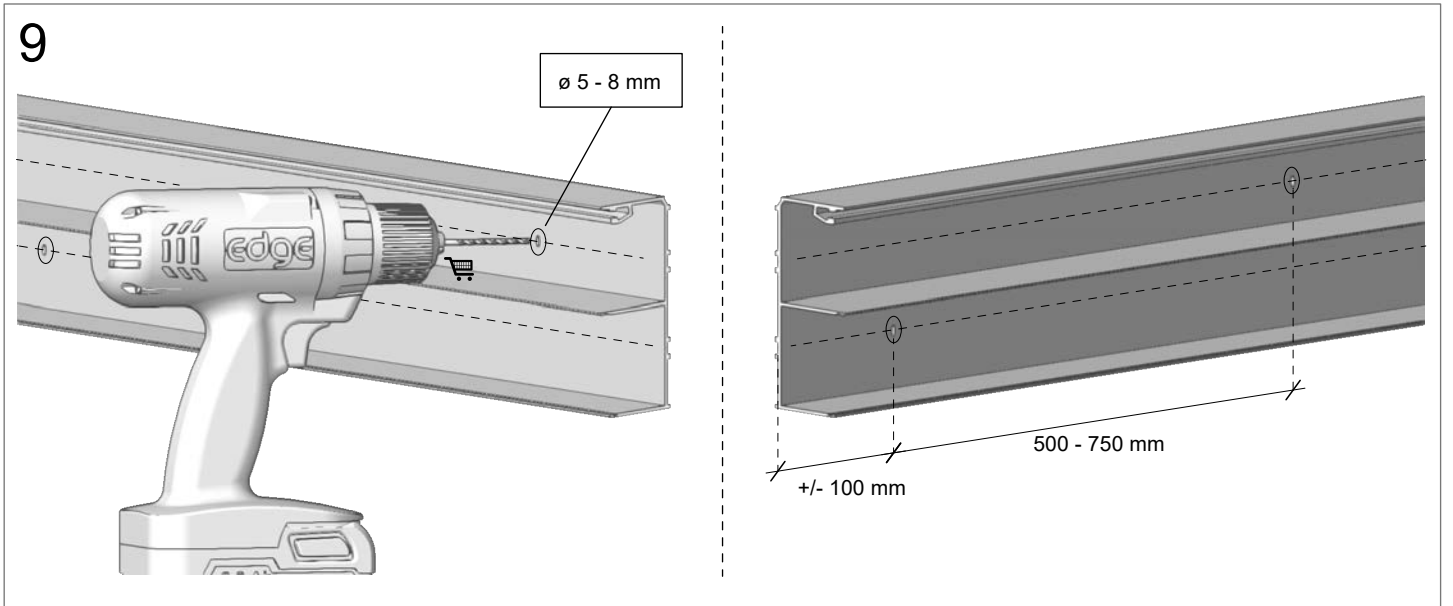
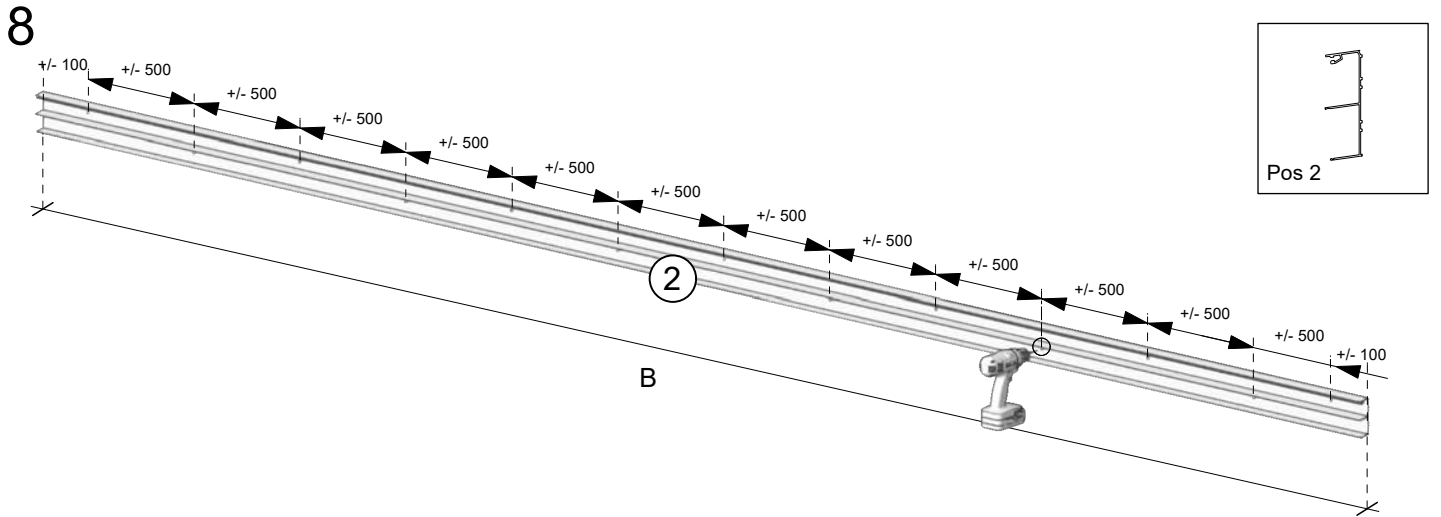

10 Voorbeeld montage / Beispiel montage / Example instructions / Exemple mode d'emploi



>> 25 ( pag 17 )

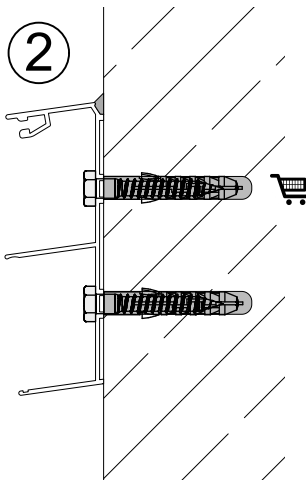

Beton-baksteen / Beton-Steine  
Concrete-bricks / Béton-brique

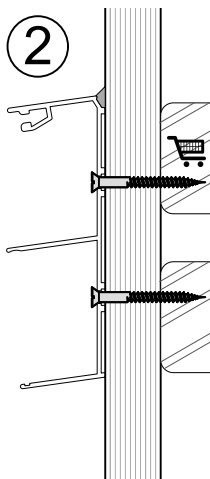

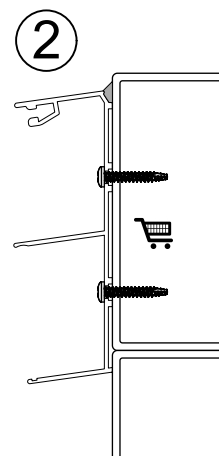

Hout / Holz  
Wood / Bois



Aluminium / Aluminium  
Alumimium / Aluminium

Niet inbegrepen  
Nicht enthalten  
Not included !  
Not inclus



**Vorbereitung Led spots ( optie )**  
**Vorbereitung LED-Spots ( optie )**

 **Preparation led spots ( option )**  
 **Préparation spots led ( option )**

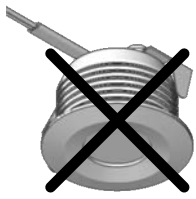
11

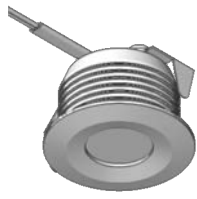

step 18



step 12

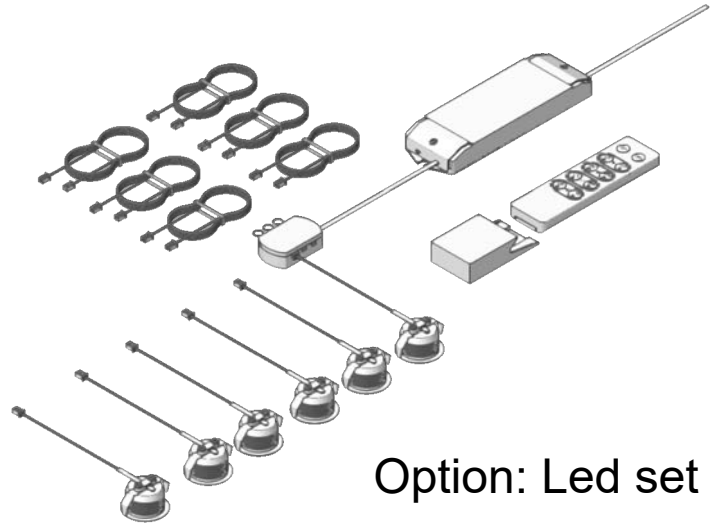

Option: Led set

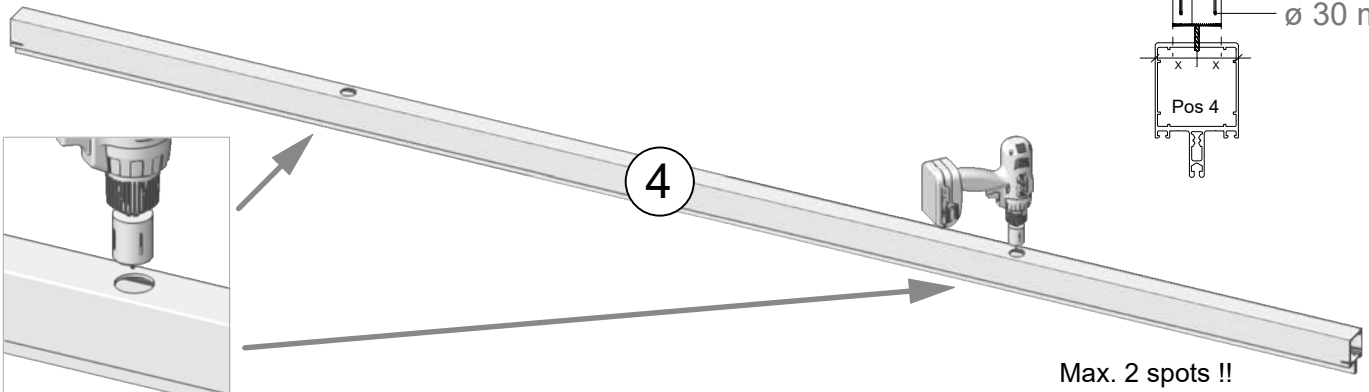

12



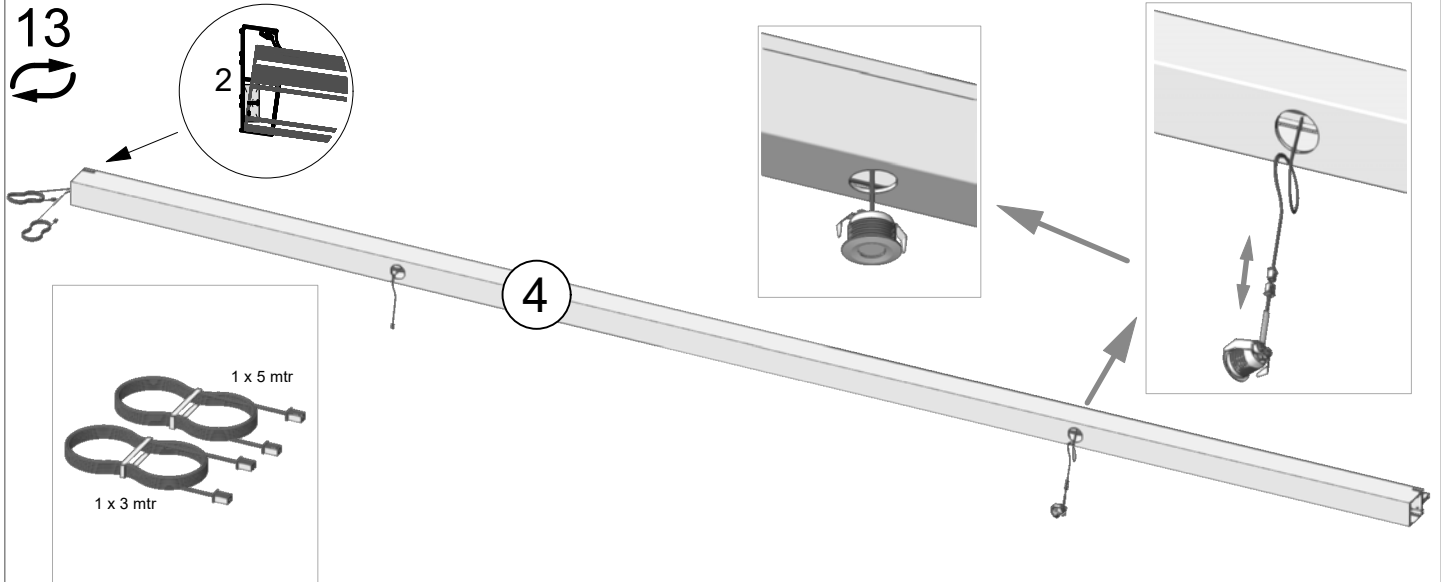

Max. 2 spots !!

13



 Voorbereiding Led spots ( optie )  
 Vorbereitung LED-Spots ( optie )



 Preparation led spots ( option )  
 Préparation spots led ( option )

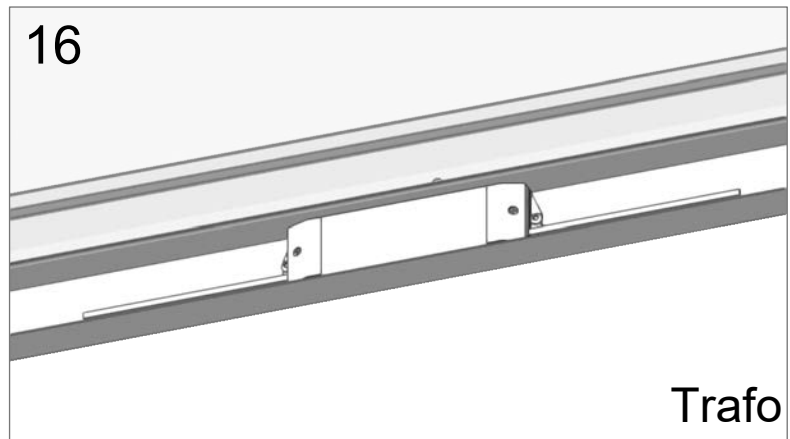
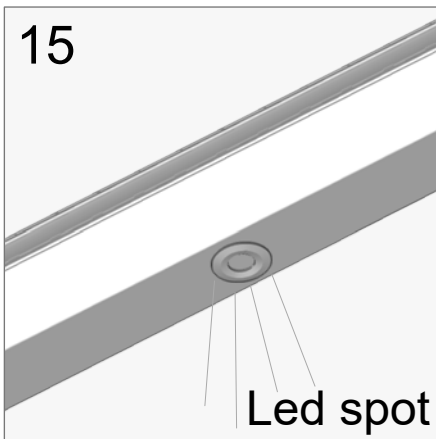
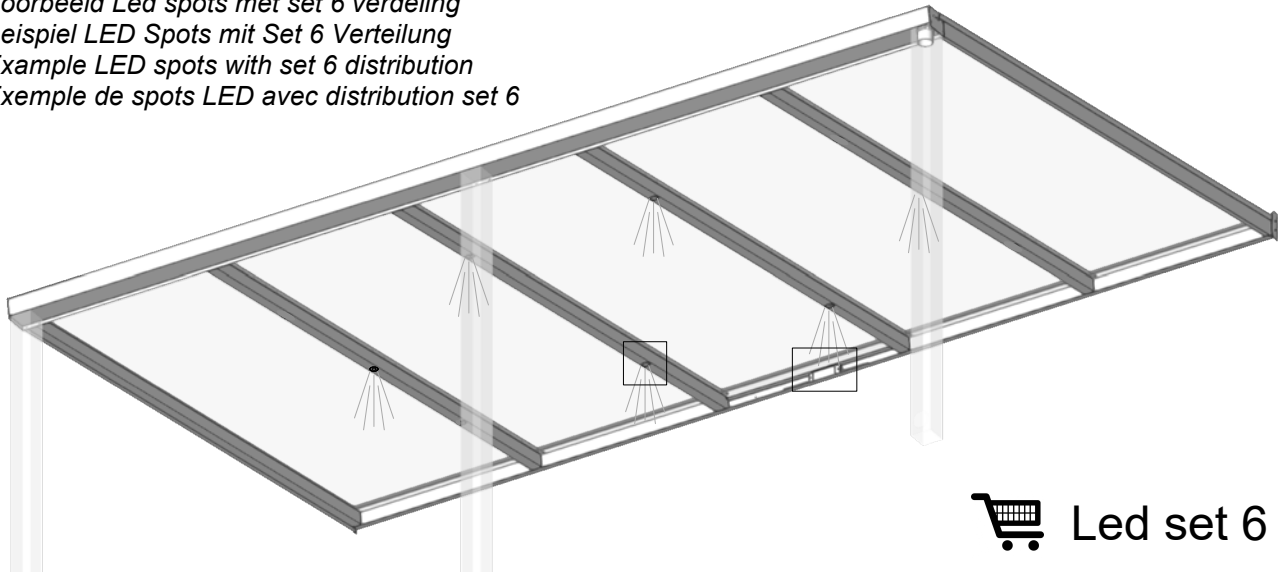

**14** Voorbeeld Led spots met set 6 verdeling  
 Beispiel LED Spots mit Set 6 Verteilung  
 Example LED spots with set 6 distribution  
 Exemple de spots LED avec distribution set 6

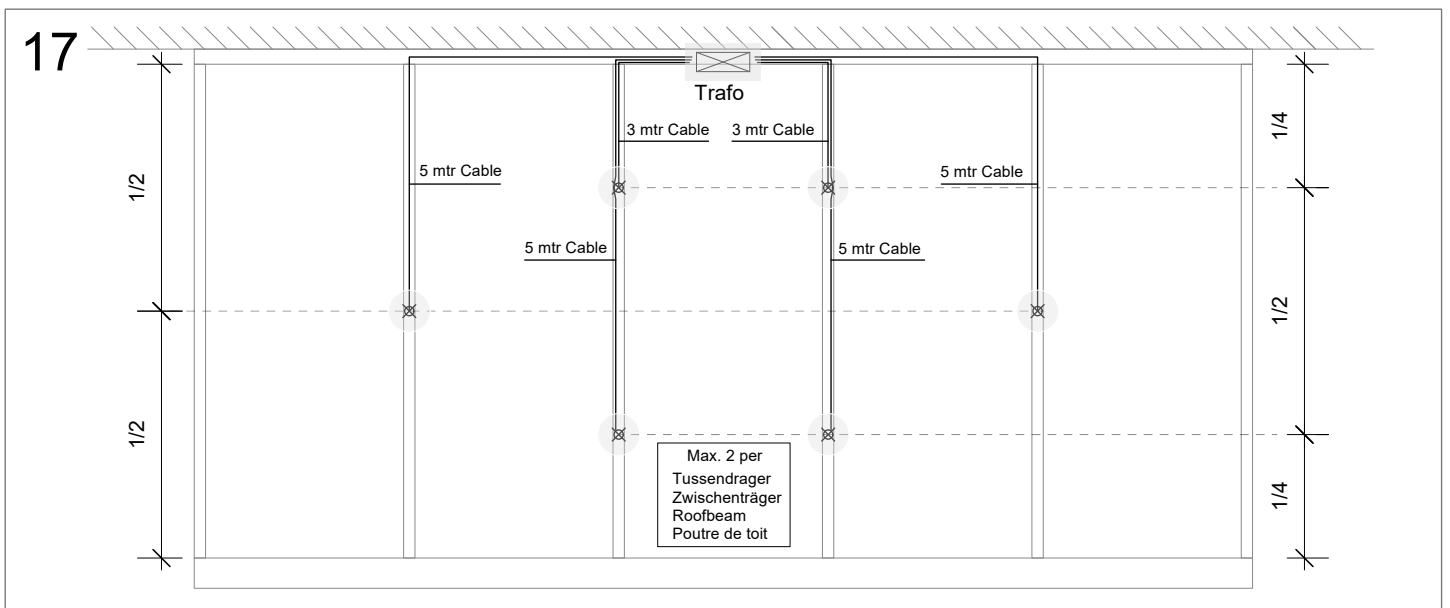



Voorbeeld / Beispiel / Example / Exemple ( 6 led )

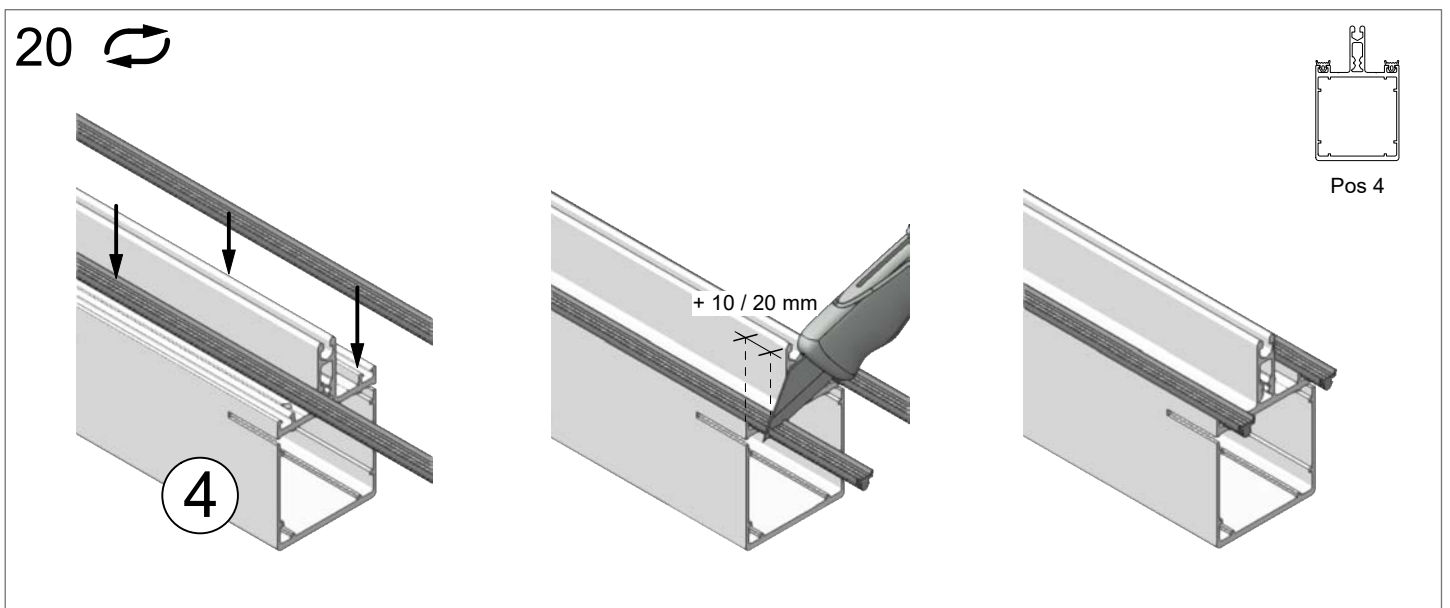
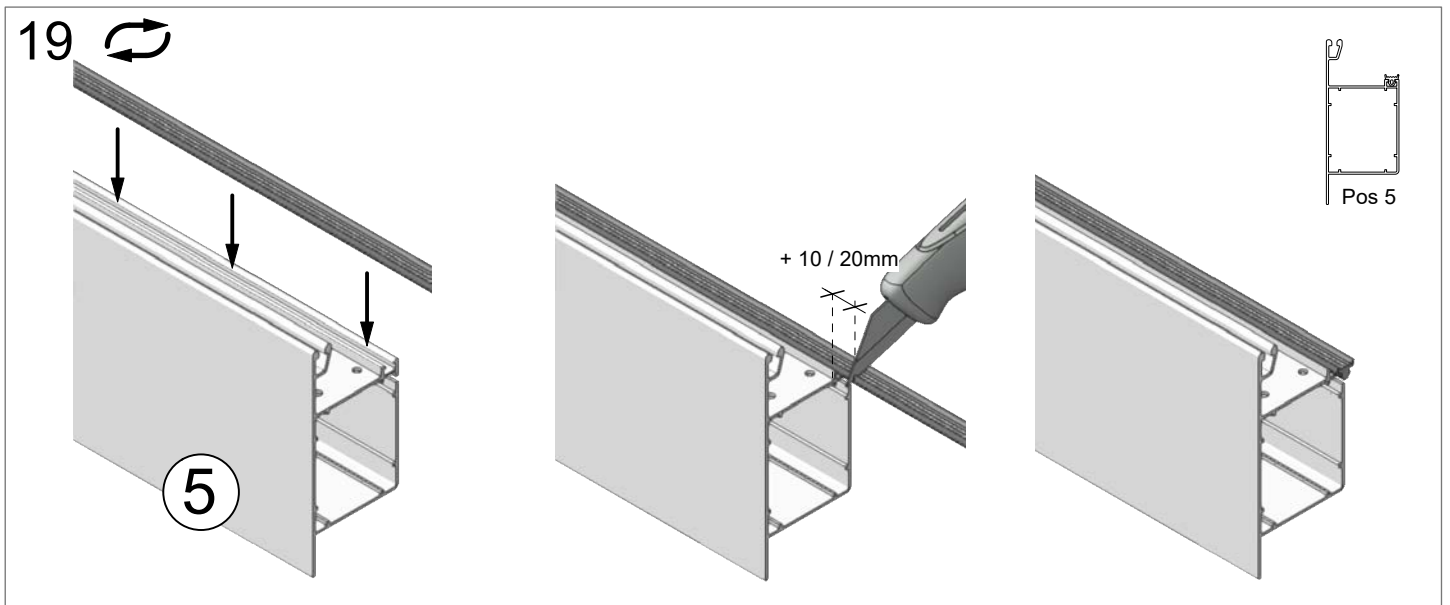
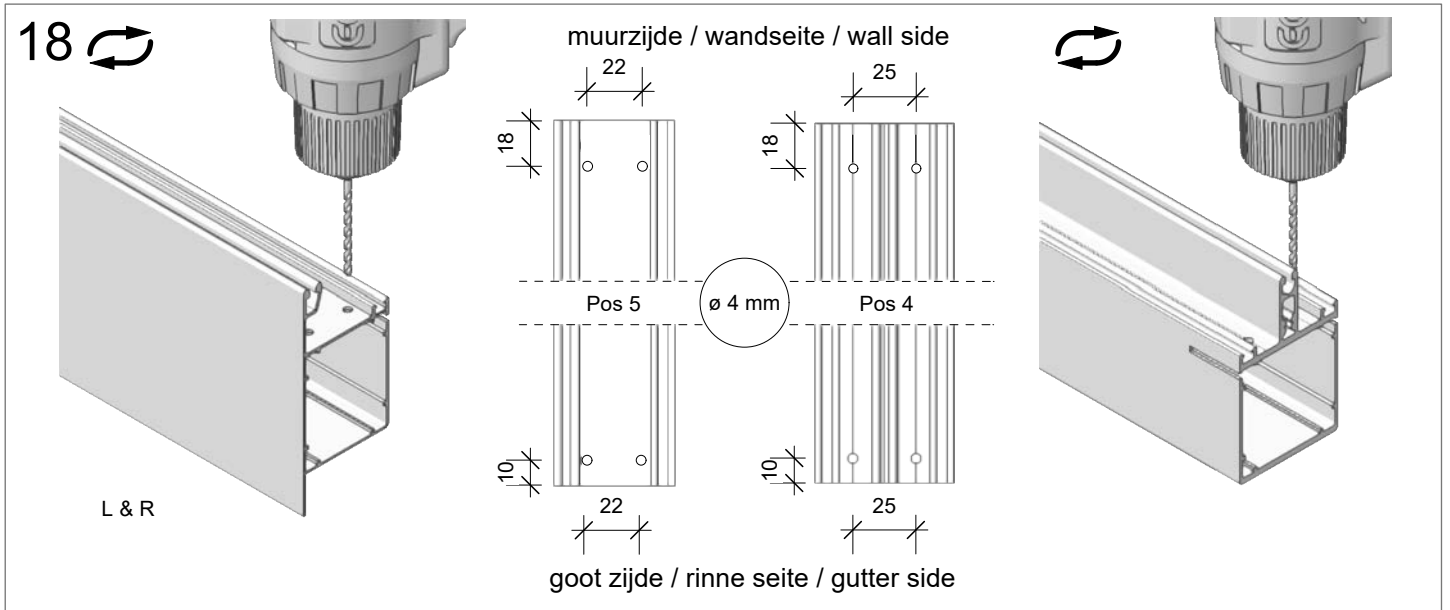

 Voorbereiding dakliggers  
 Vorbereitung Trägers

 Preparation roofbeams  
 Préparation poutres de toit



 Afdichtingsrubber in de afdekkers aanbrengen  
Gummi in de Abdecker anbrengen

 Preparation Gasket in profile

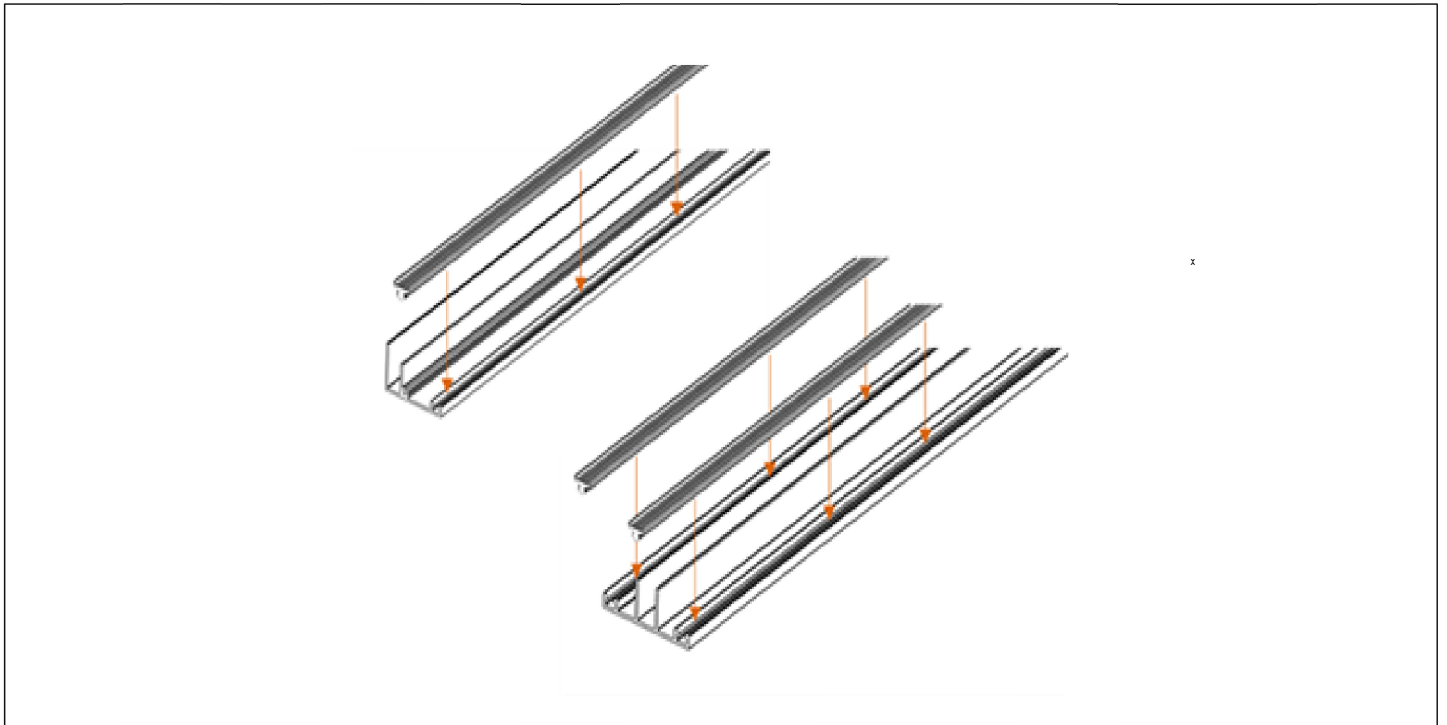

 Afdekker voorbereiden  
Abdecker vorbereiten

 Preparation cover profile

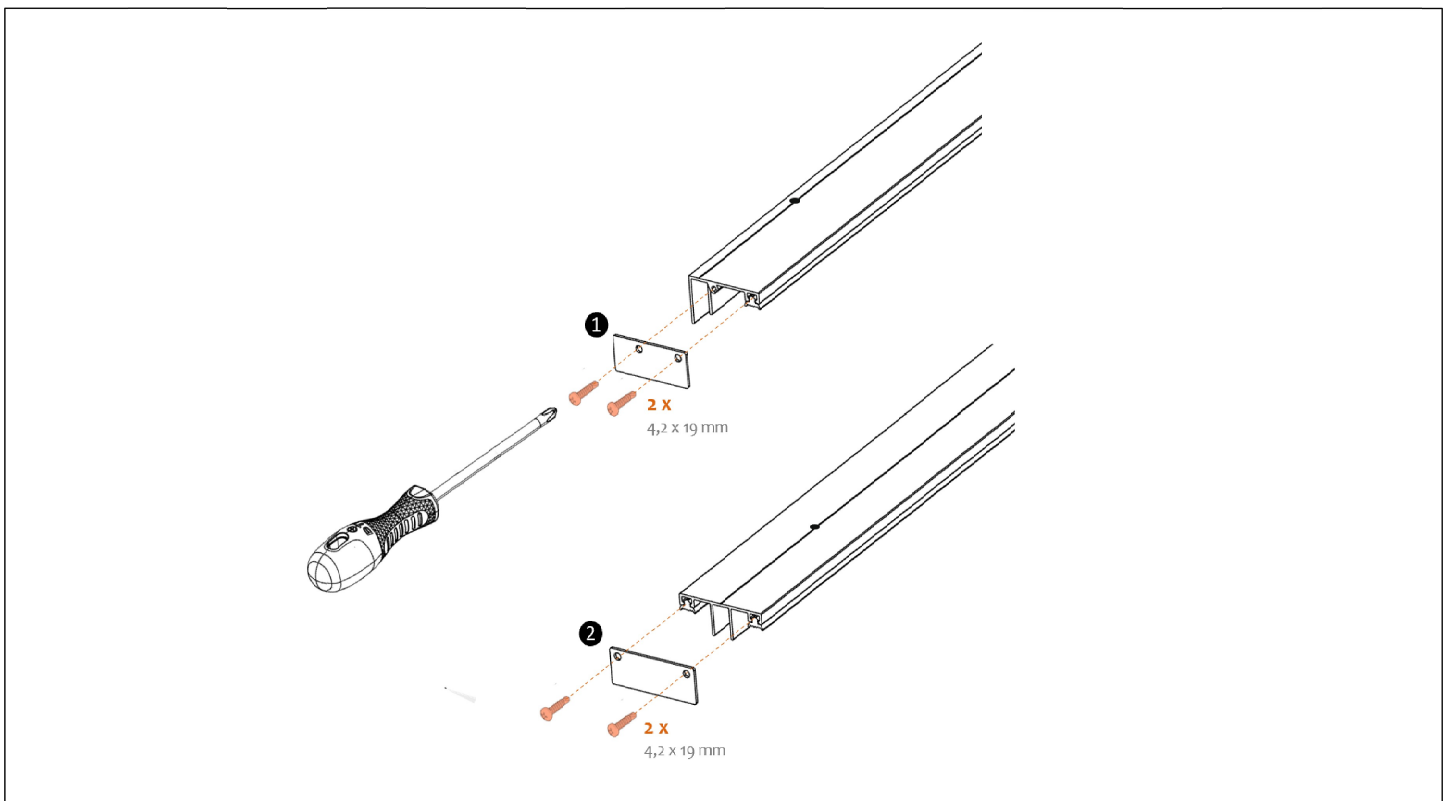

## 21 Optie A

**Montage zonder betonpoeren**  
**Montage ohne Betonfüße**  
**Mounting without concrete feet**  
**Montage sans pieds en beton**

**Montage op bijv. #**  
**Montage auf beispiel #**  
**Mounting on example #**  
**Montage sur par exemple #**

**Niet statisch berekend**  
**Nicht statisch berechnet**  
**Not statically calculated**  
**Non calculé statiquement**

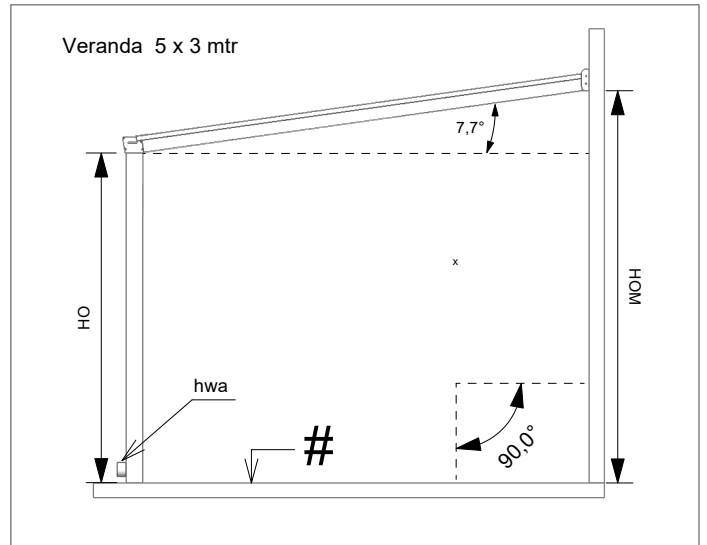



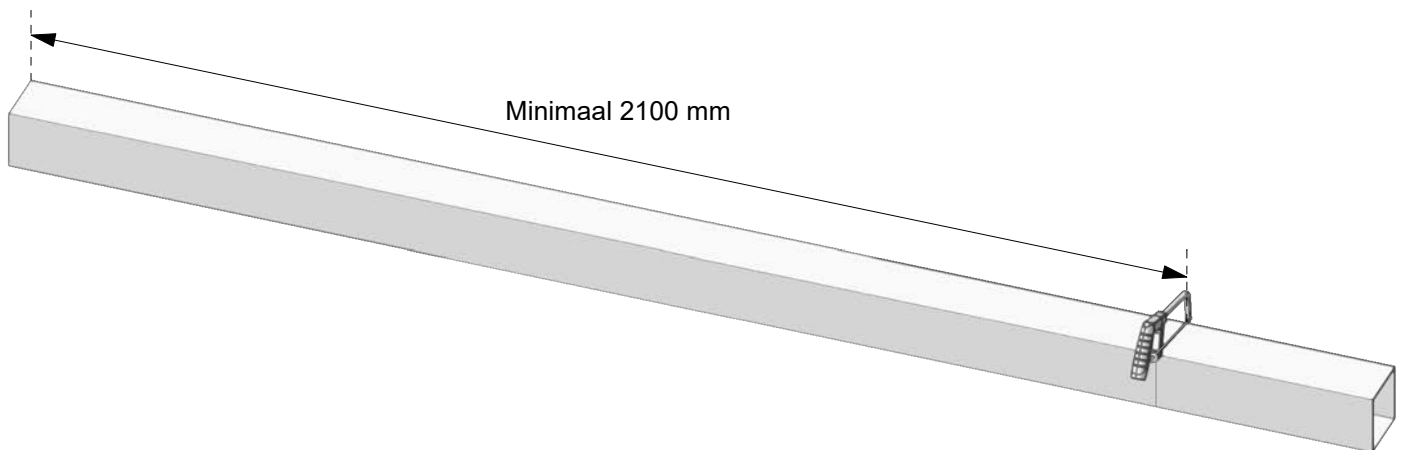

## 22

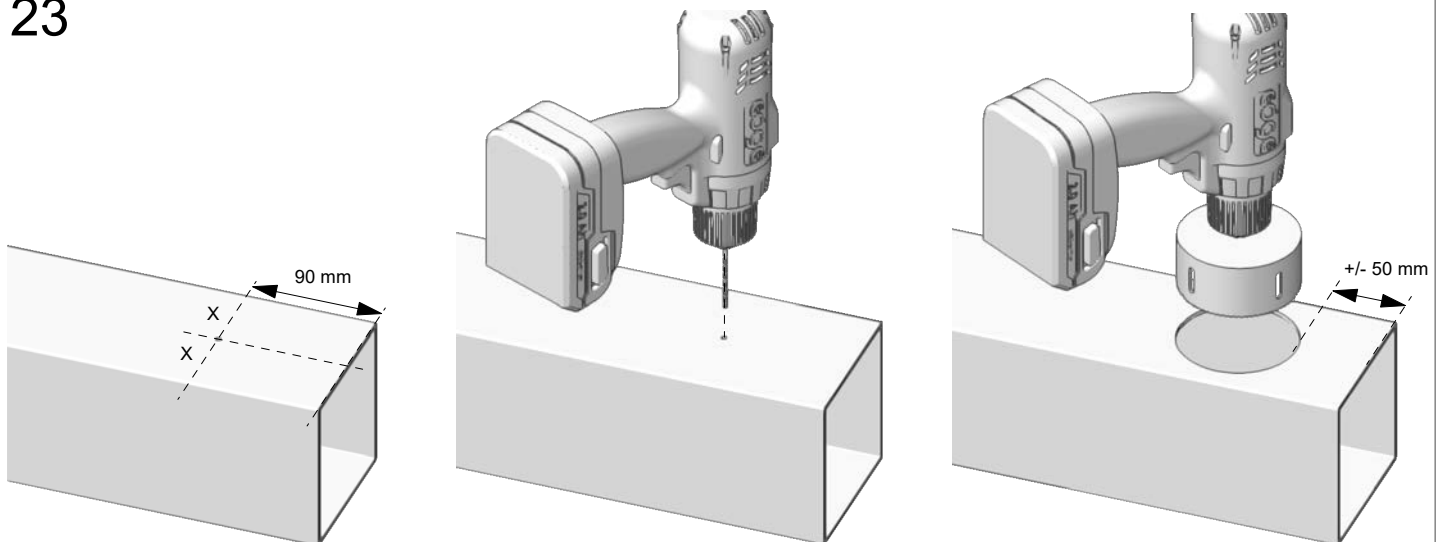

## 23



 **Montage veranda**  
 **Montage Terrassenüberdachung**

 **Assembly roof**  
 **Montage Pergola**

24

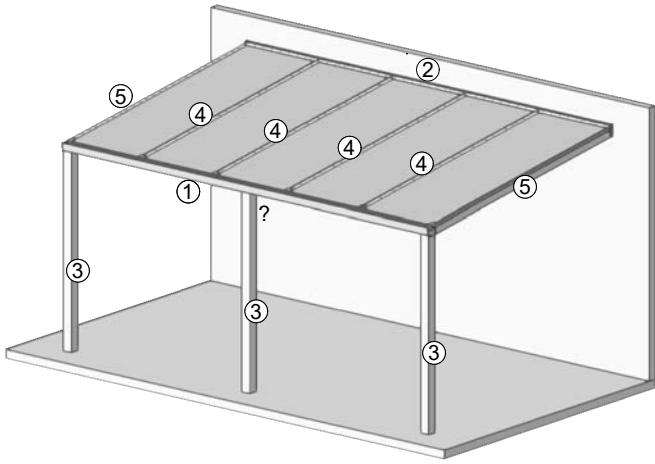

25

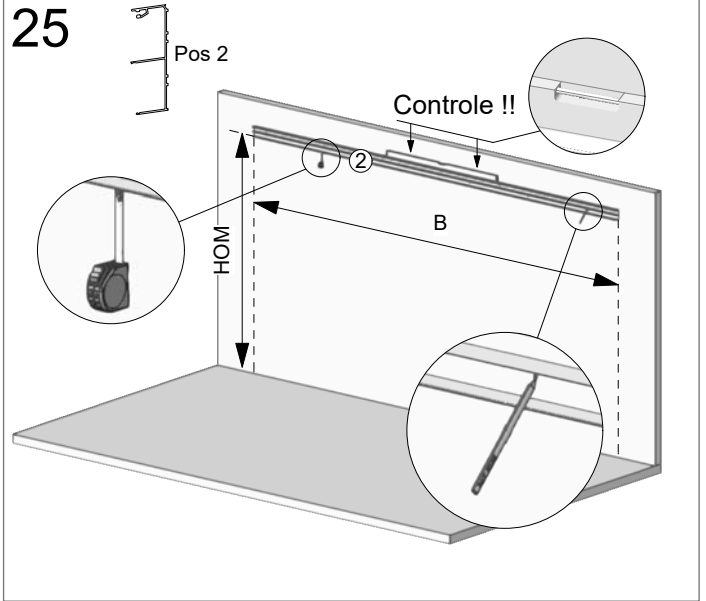

26

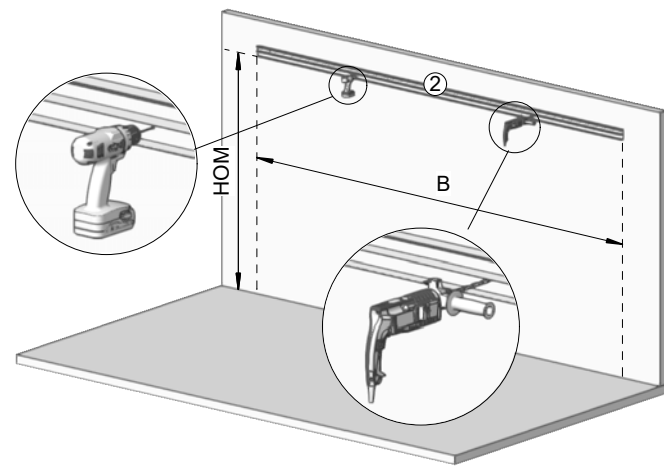

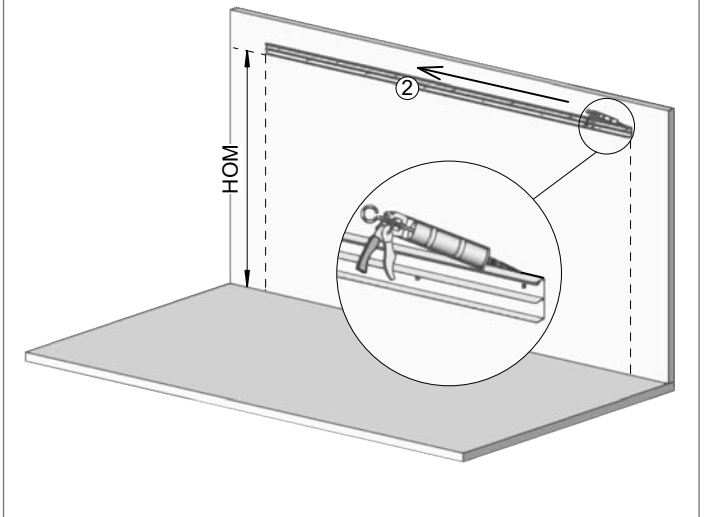

27



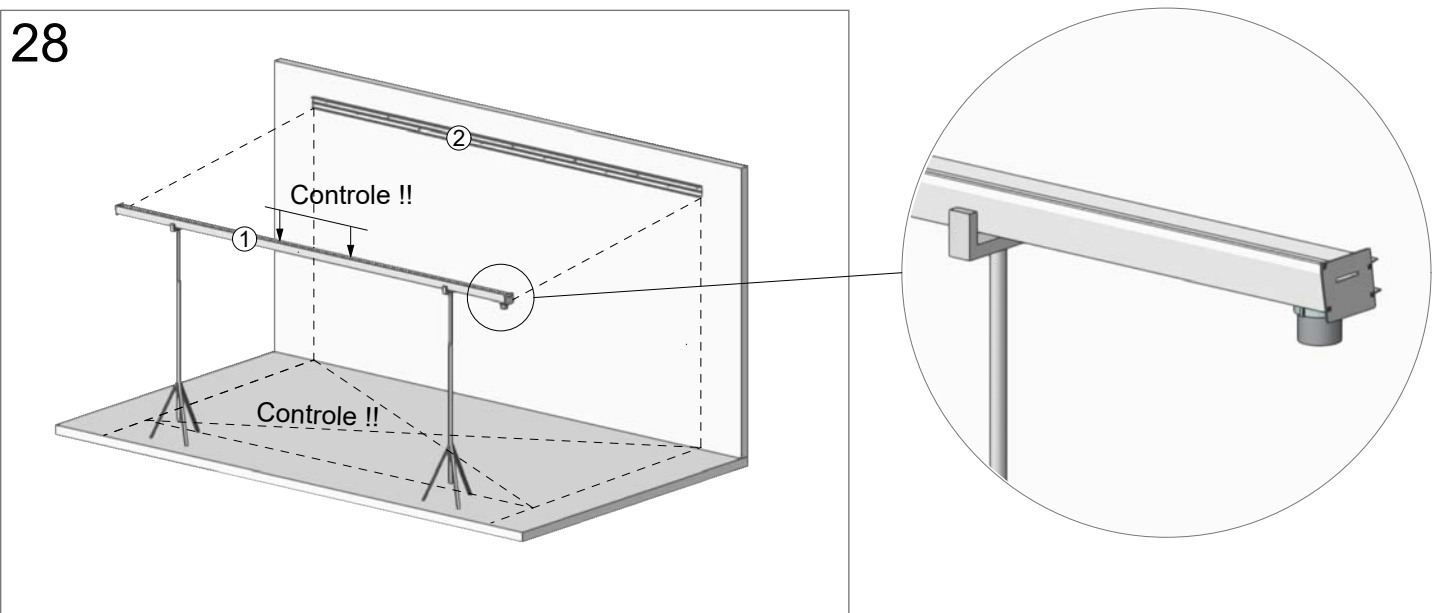

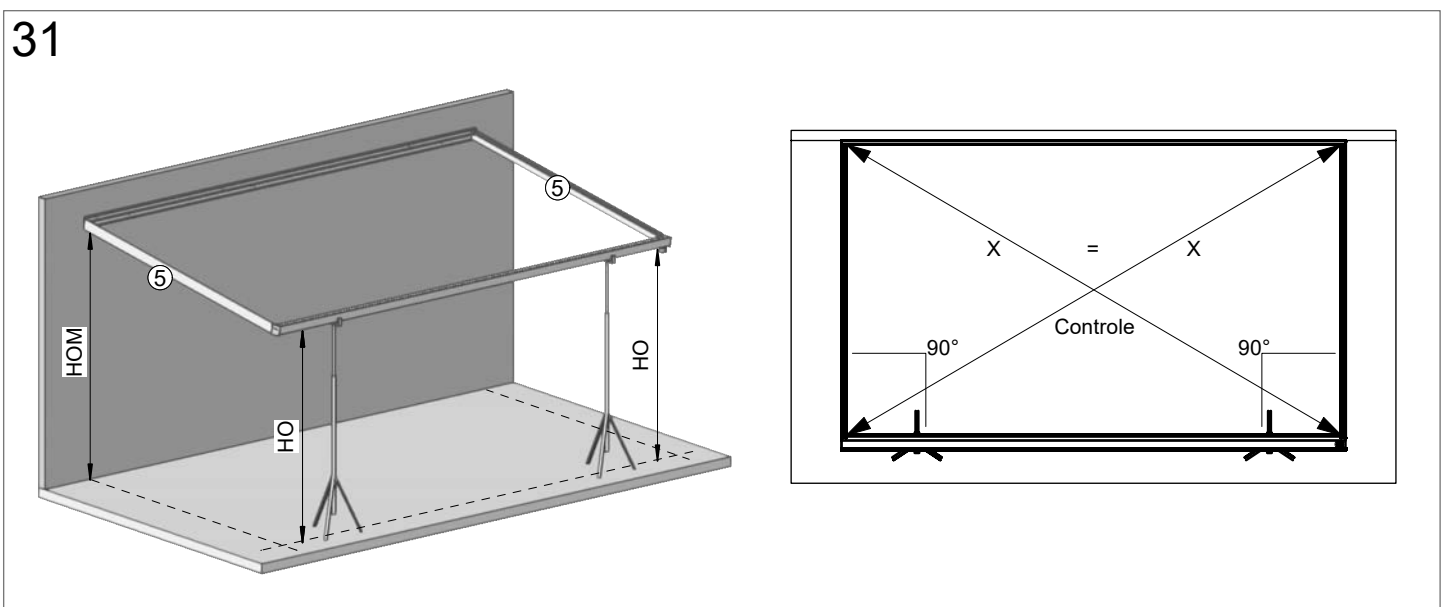
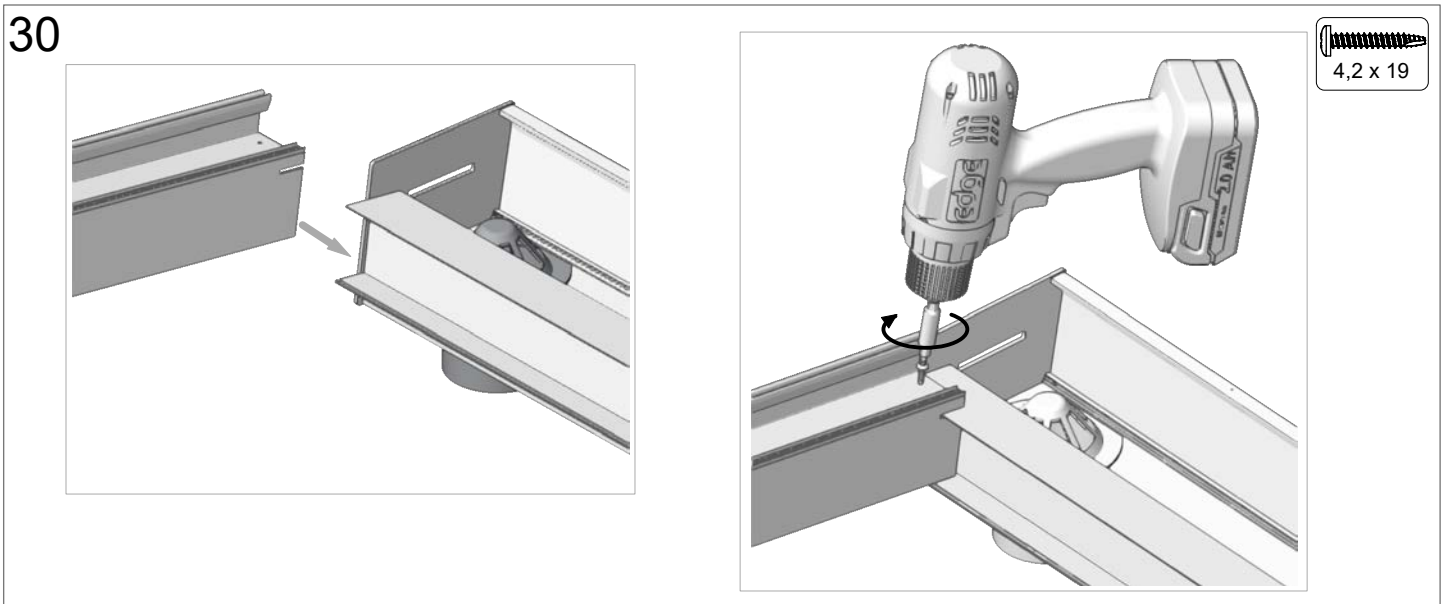
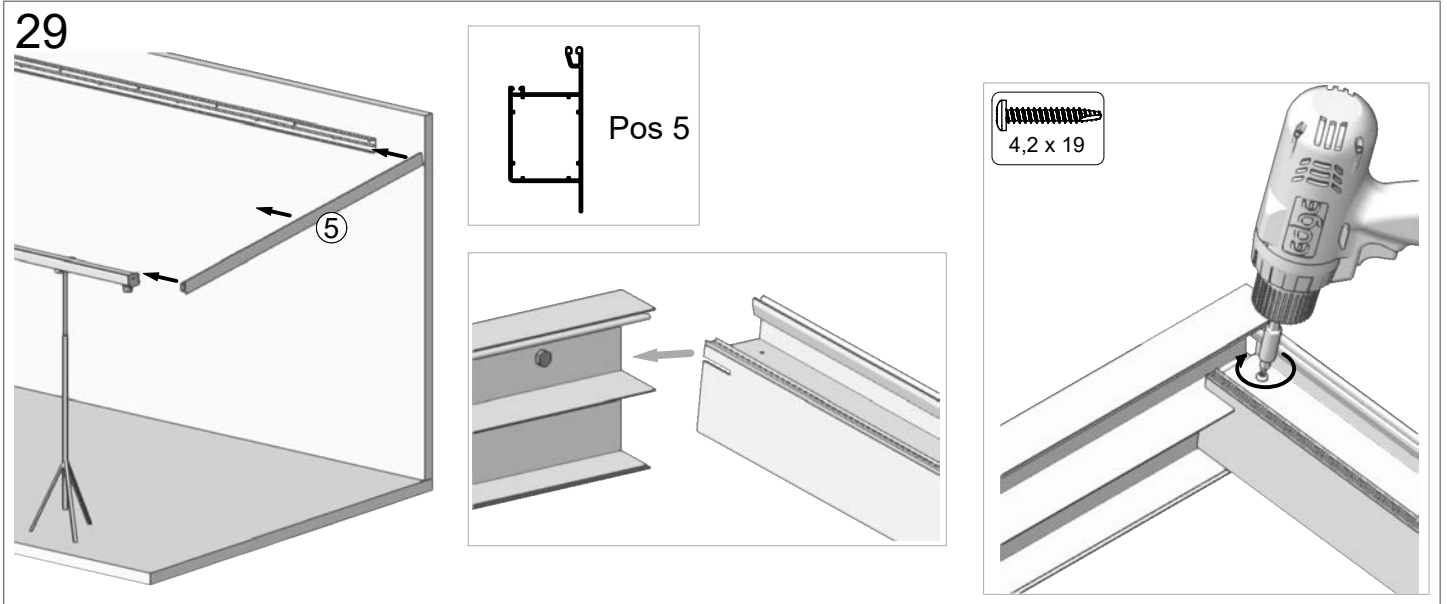
28







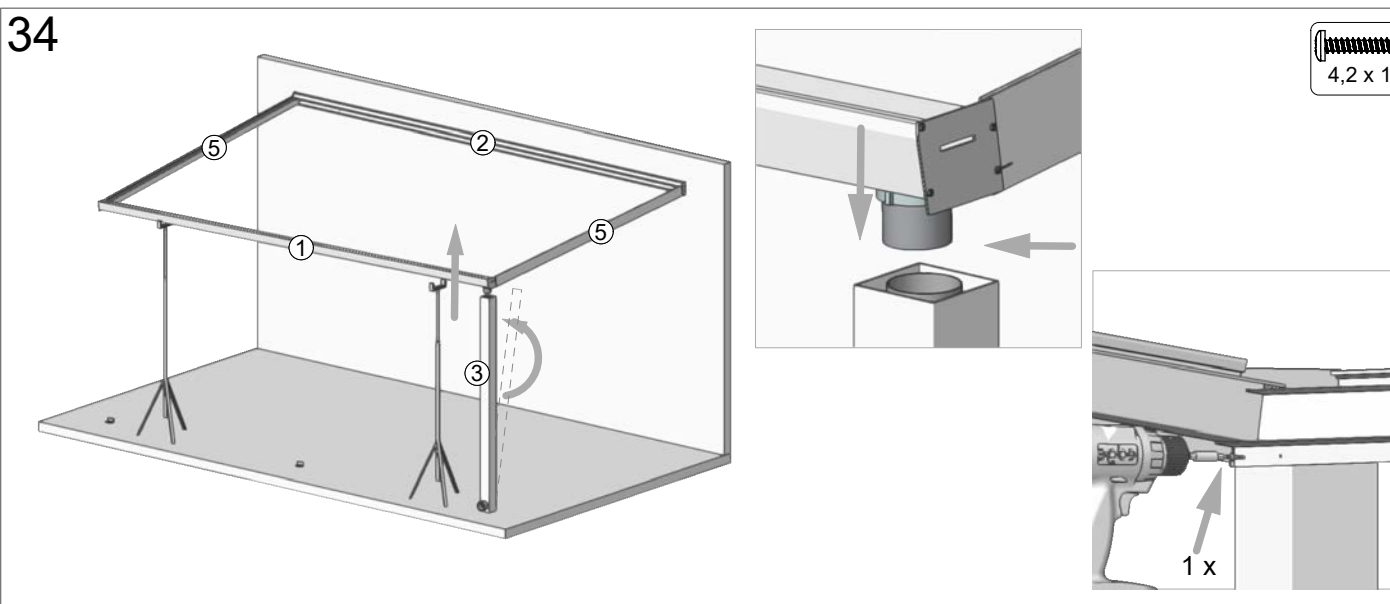
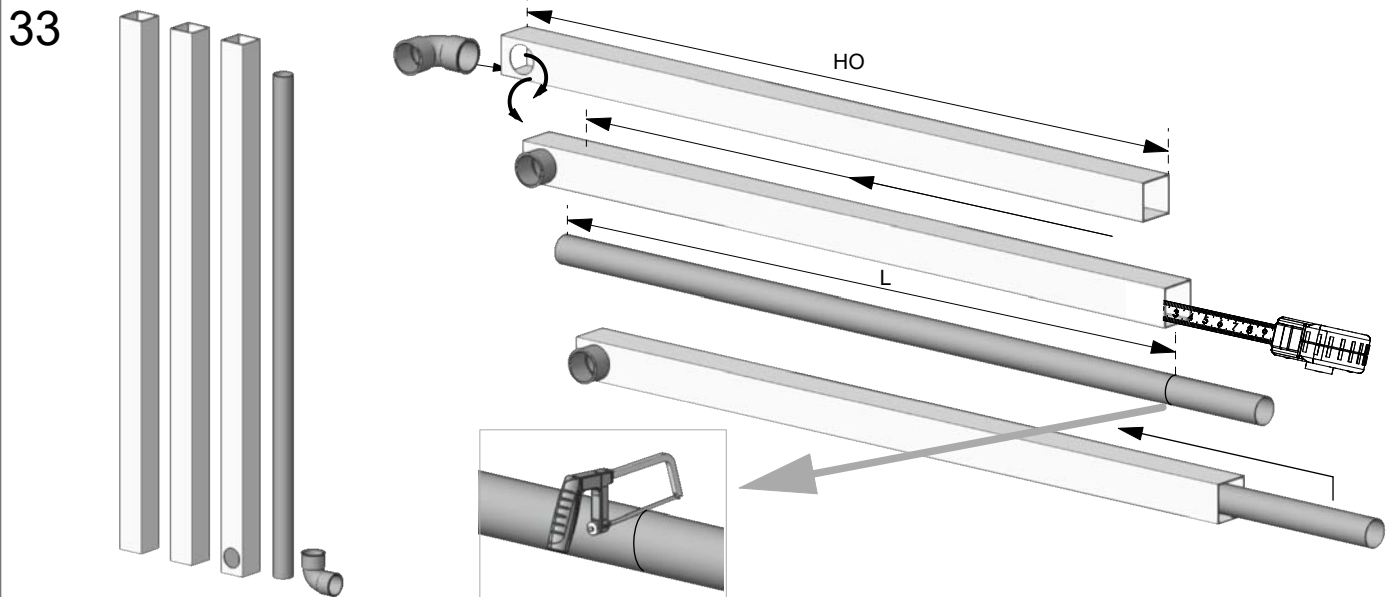
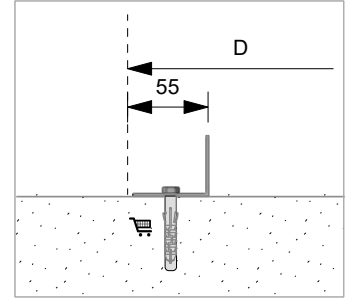
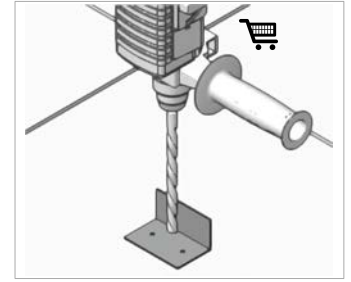
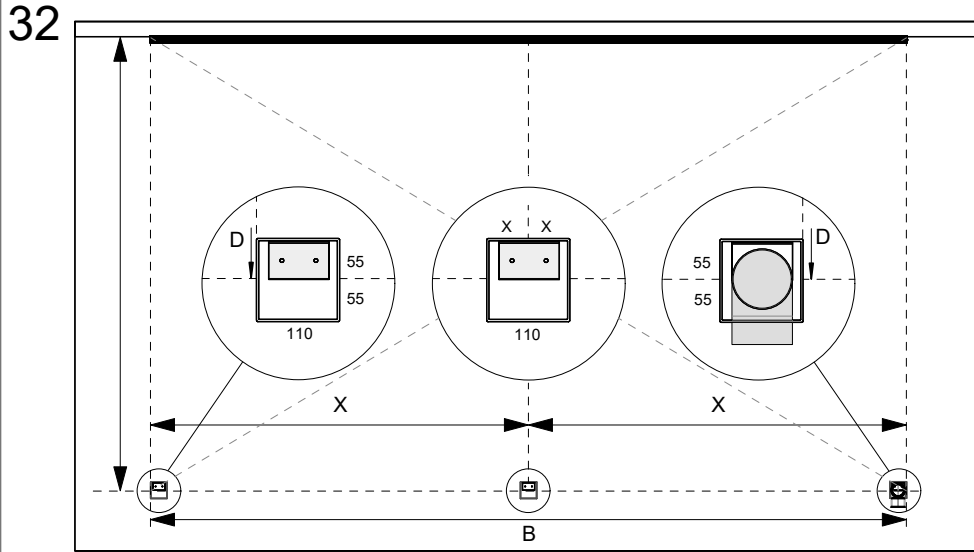

 Montage veranda (standers optie A)  
 Montage Veranda (Pfosten opties A)



 Assembly roof (poles option A)  
 Montage véranda (option A)



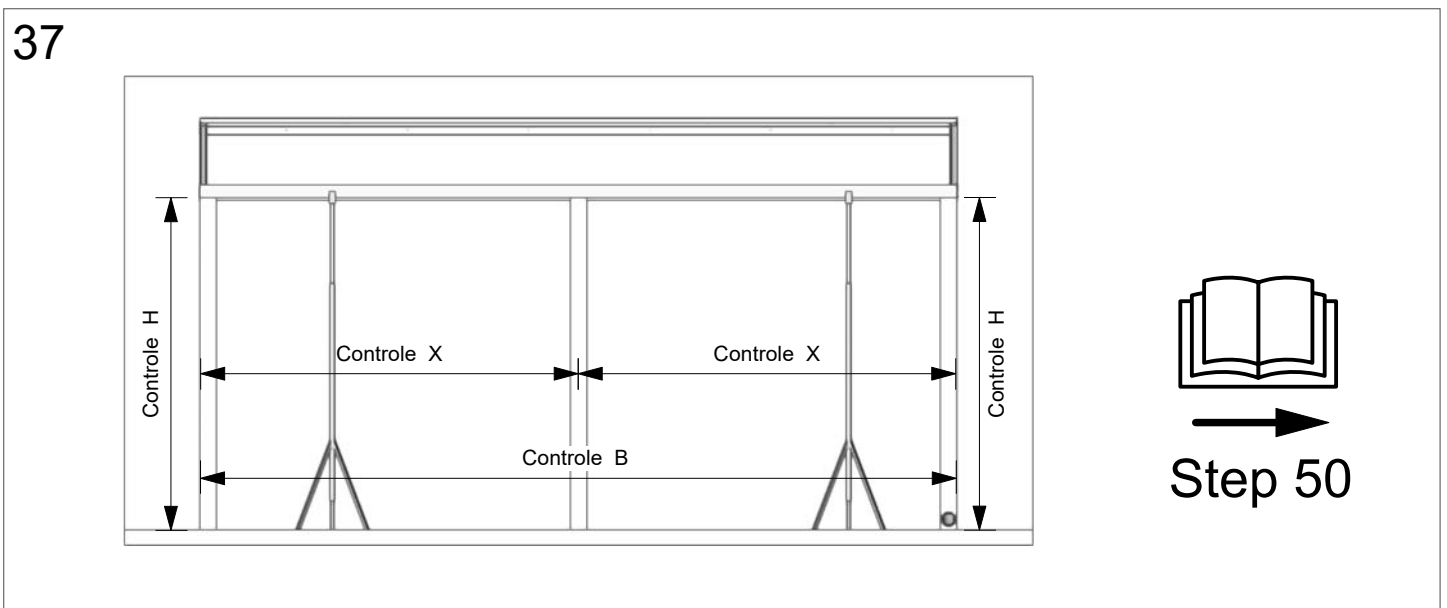
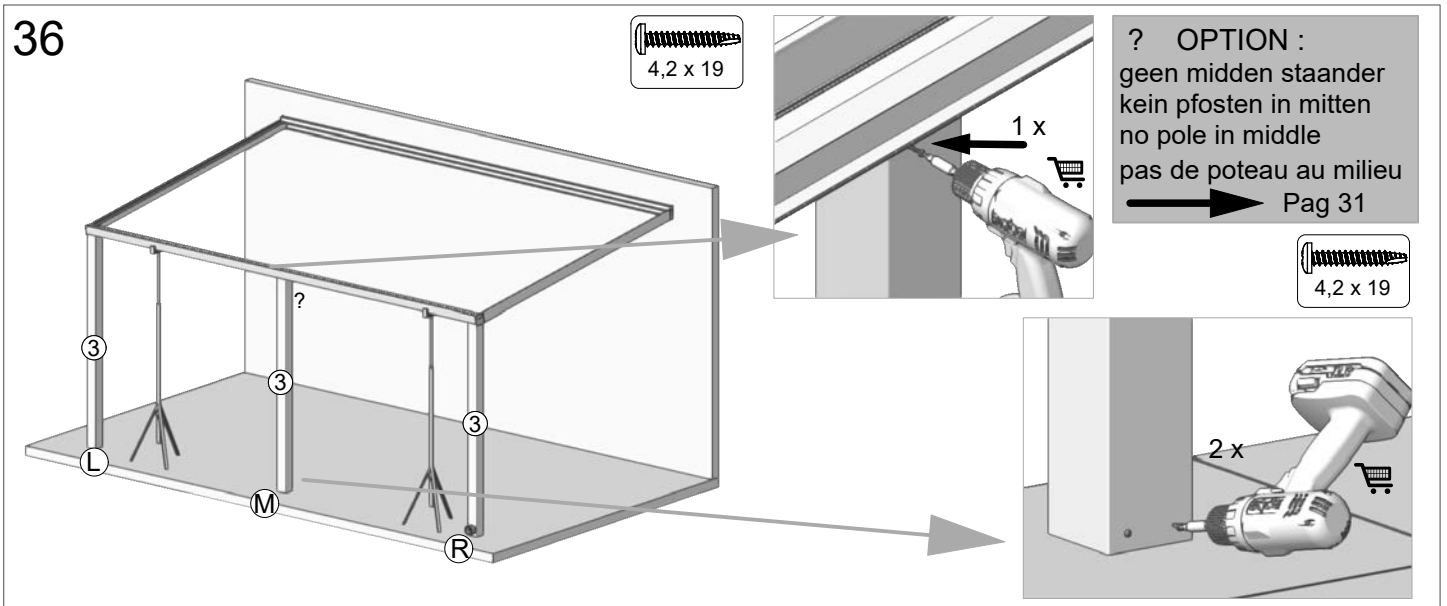
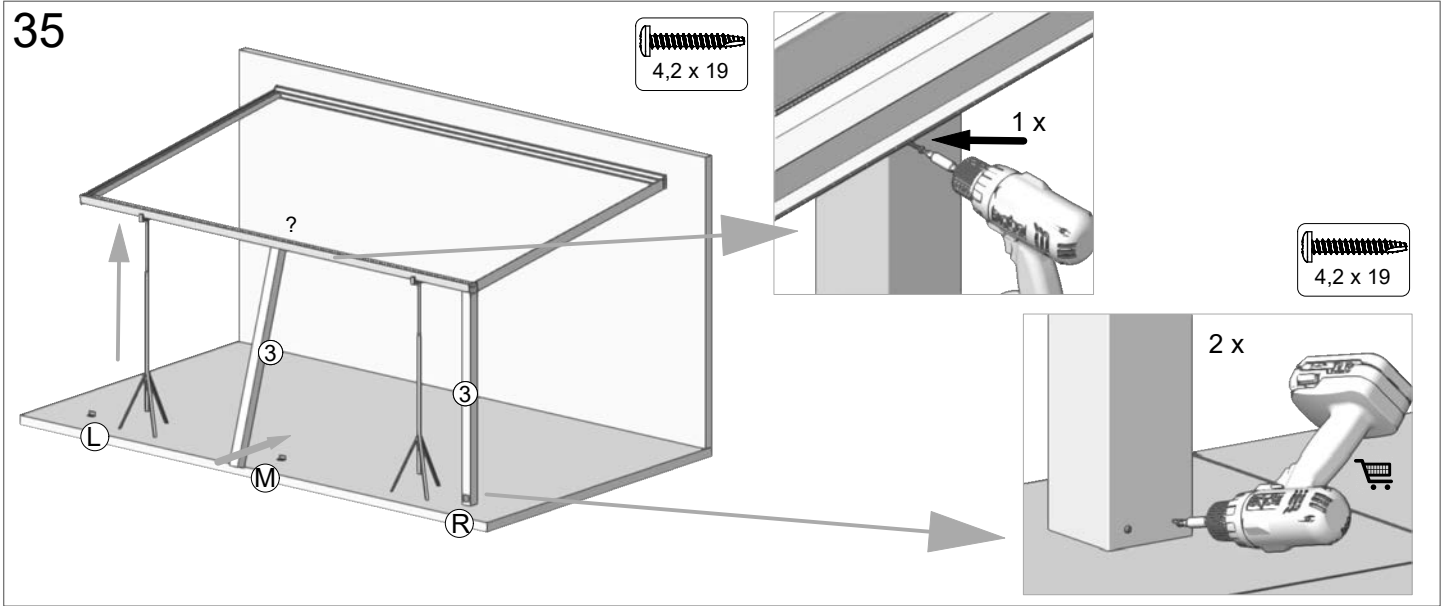

 Montage veranda (standers optie A)  
 Montage Veranda (Pfosten opties A)

 Assembly roof (poles option A)  
 Montage véranda (option A)



 Montage veranda ( staanders optie B )  
 Montage Terrassenüberdachung ( optie B )

 Assembly roof ( poles option B )  
 Montage pergola ( option B )

38

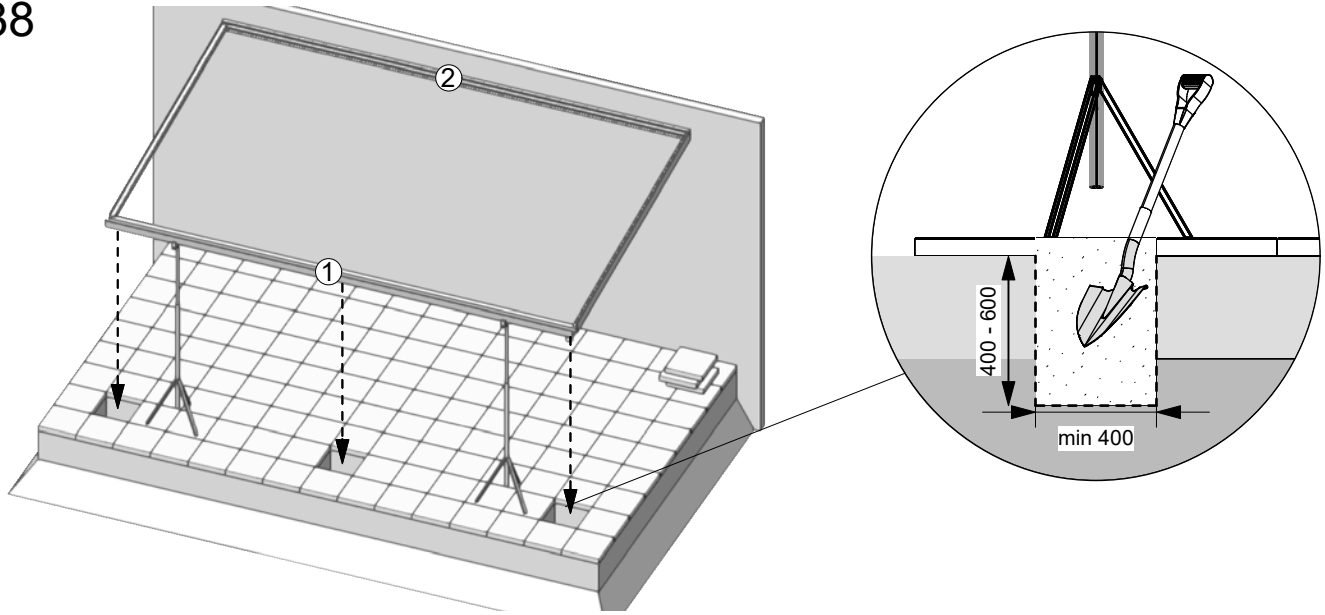



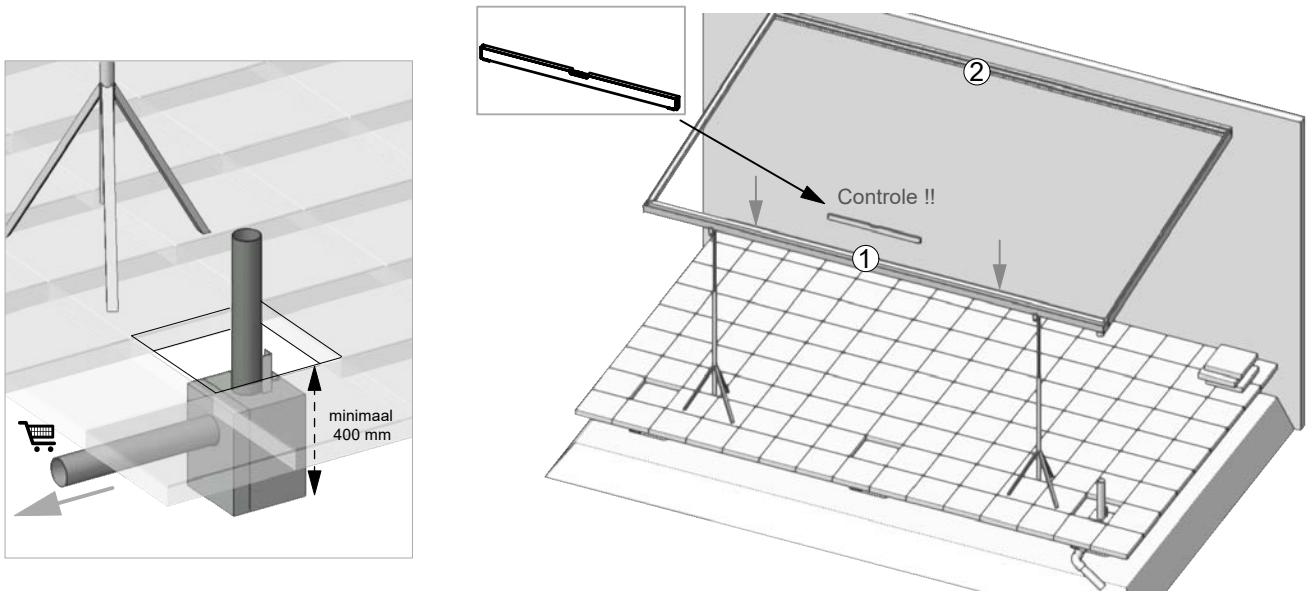

39

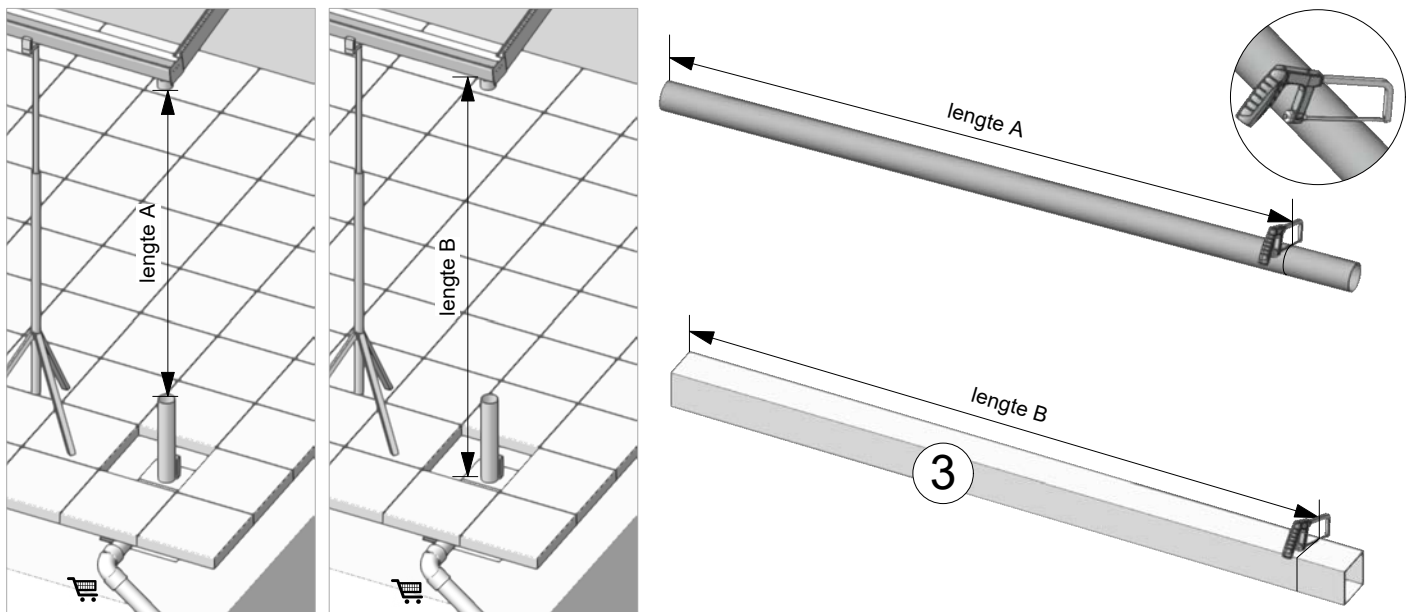

40



 Montage veranda ( staanders optie B )  
 Montage Terrassenüberdachung ( optie B )

 Assembly roof ( poles option B )  
 Montage pergola ( option B )

41

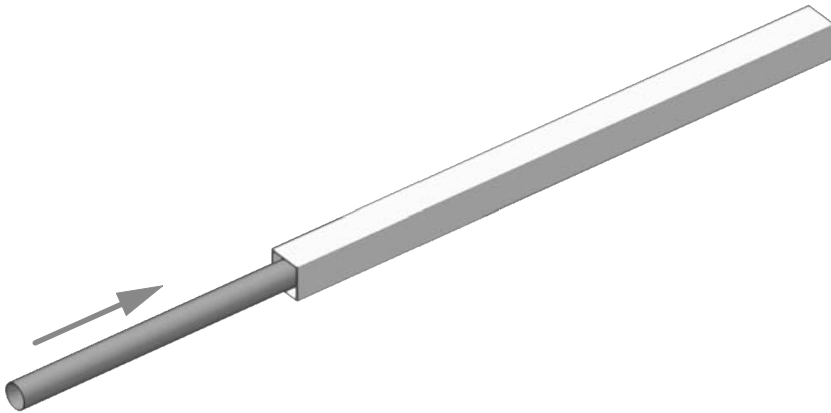

43

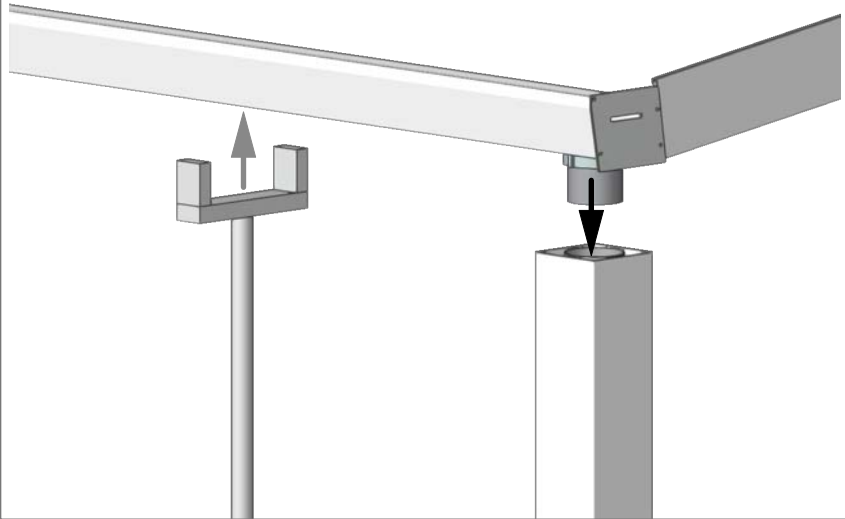



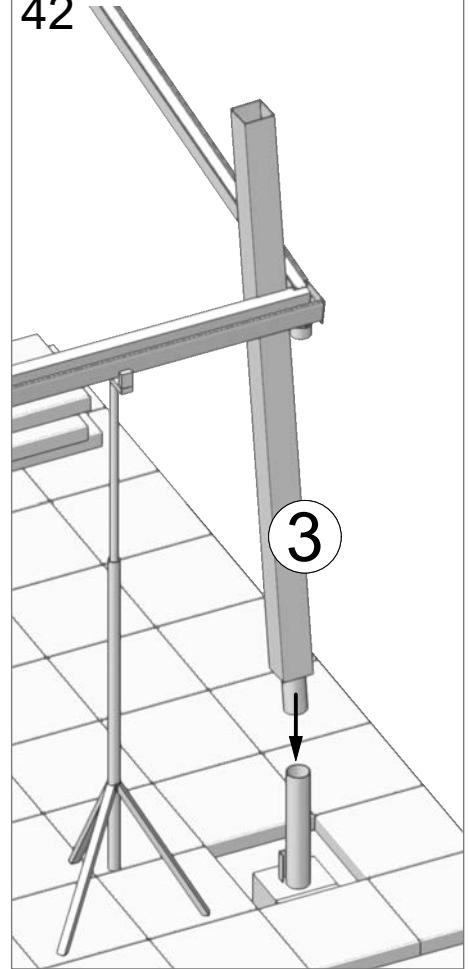

42

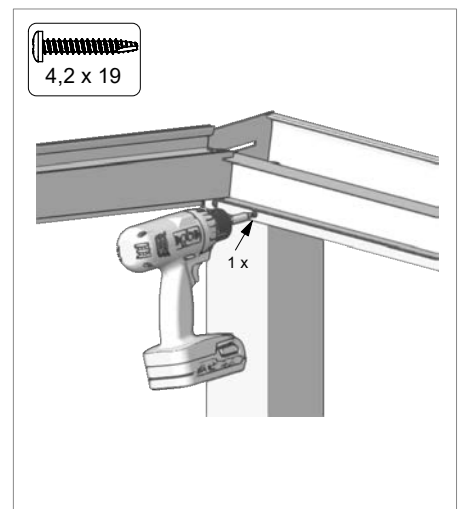
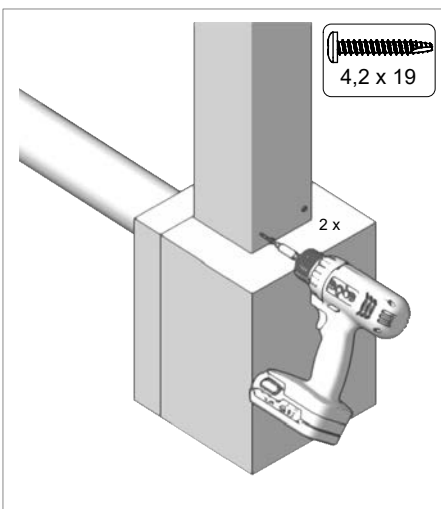



44



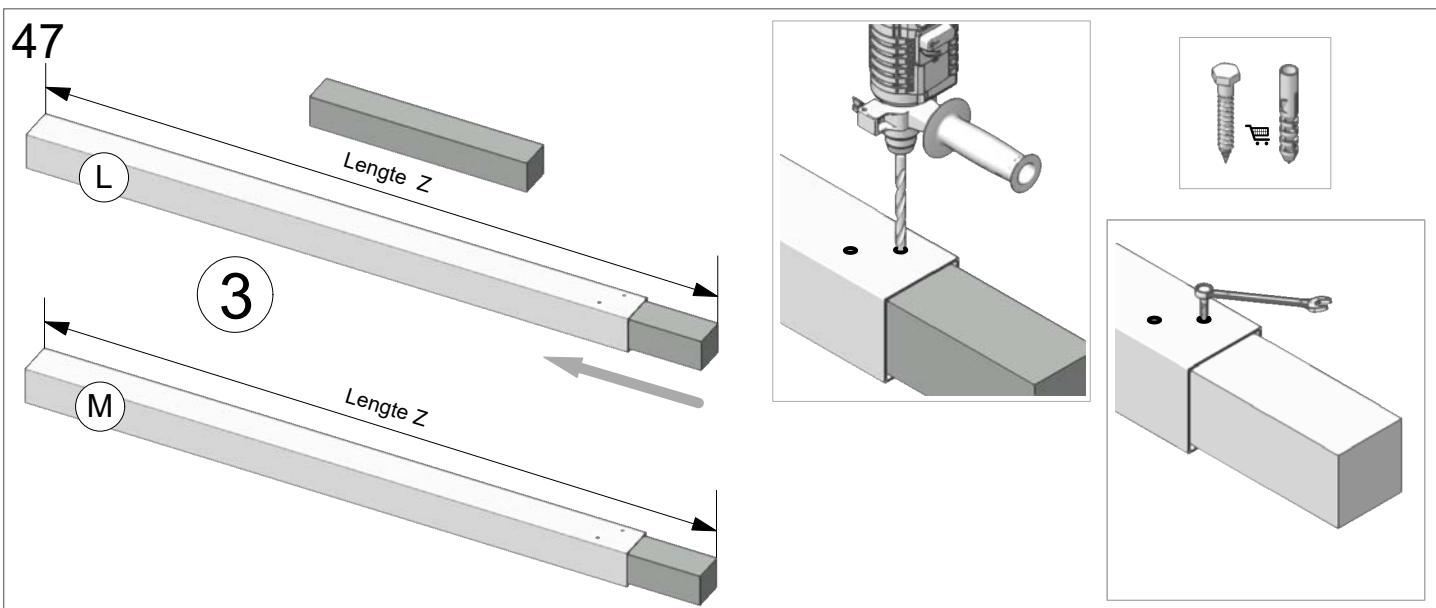
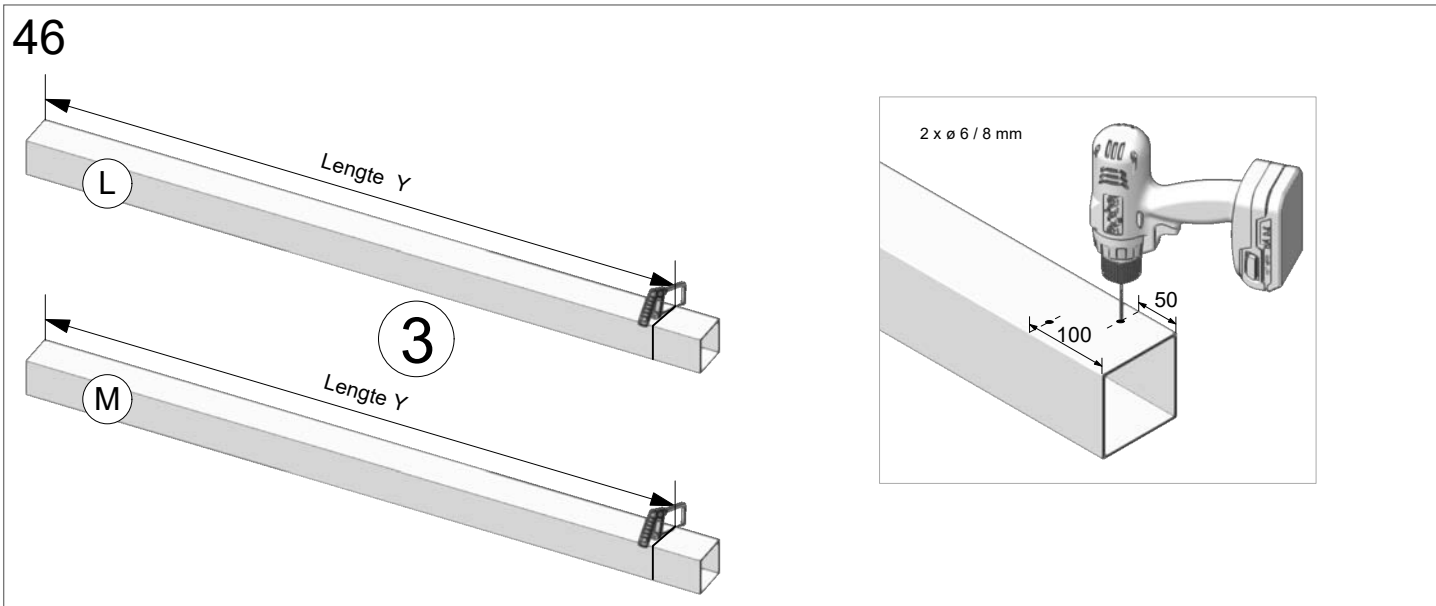
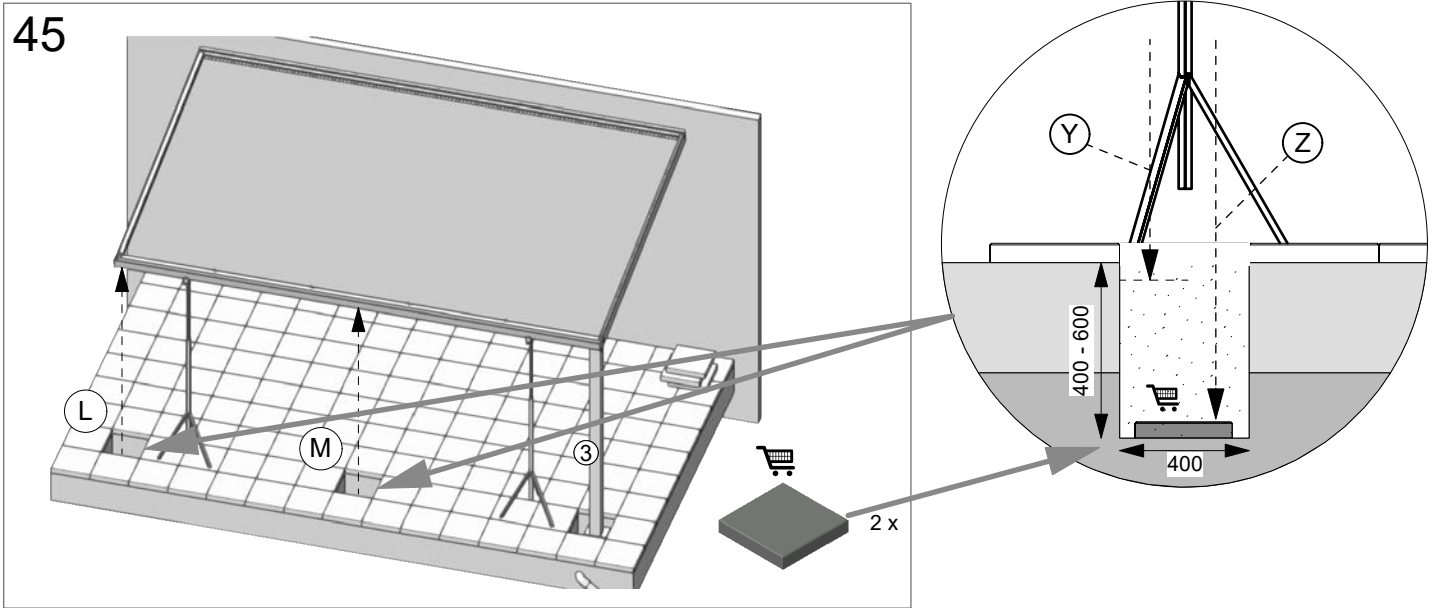

 Montage veranda (standers optie B)  
 Montage Terrassenüberdachung (optie B)



 Assembly roof (poles option B)  
 Montage pergola (option B)



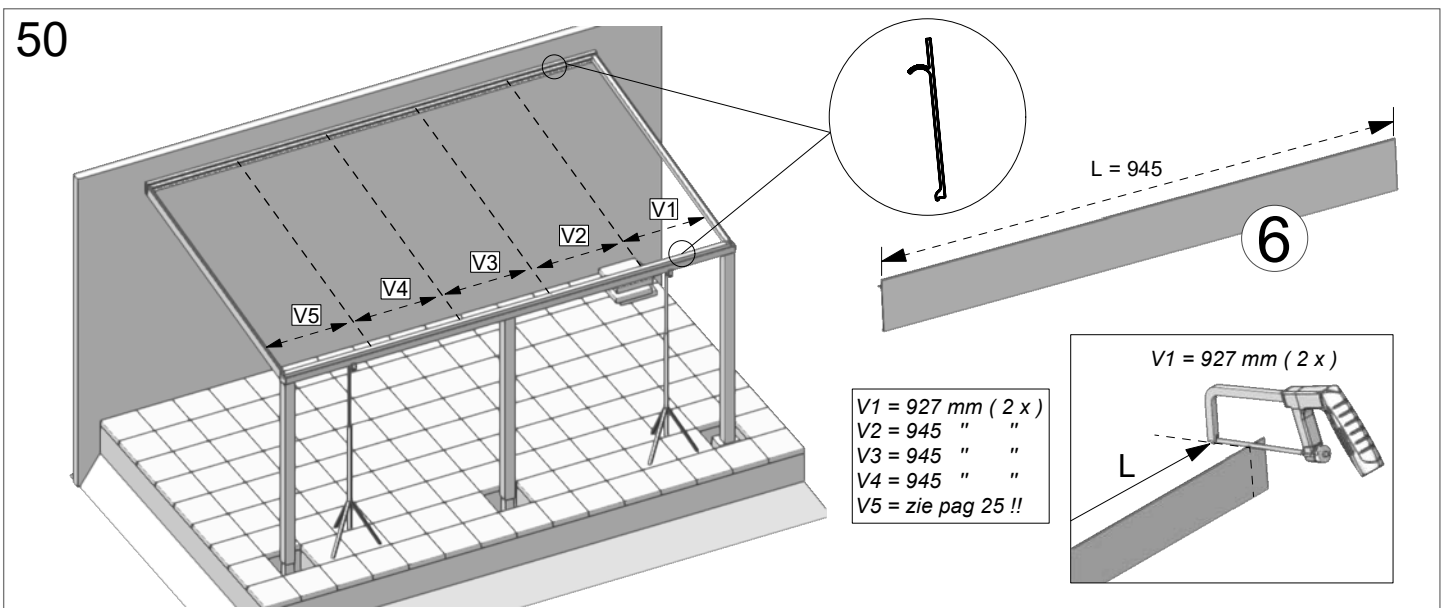
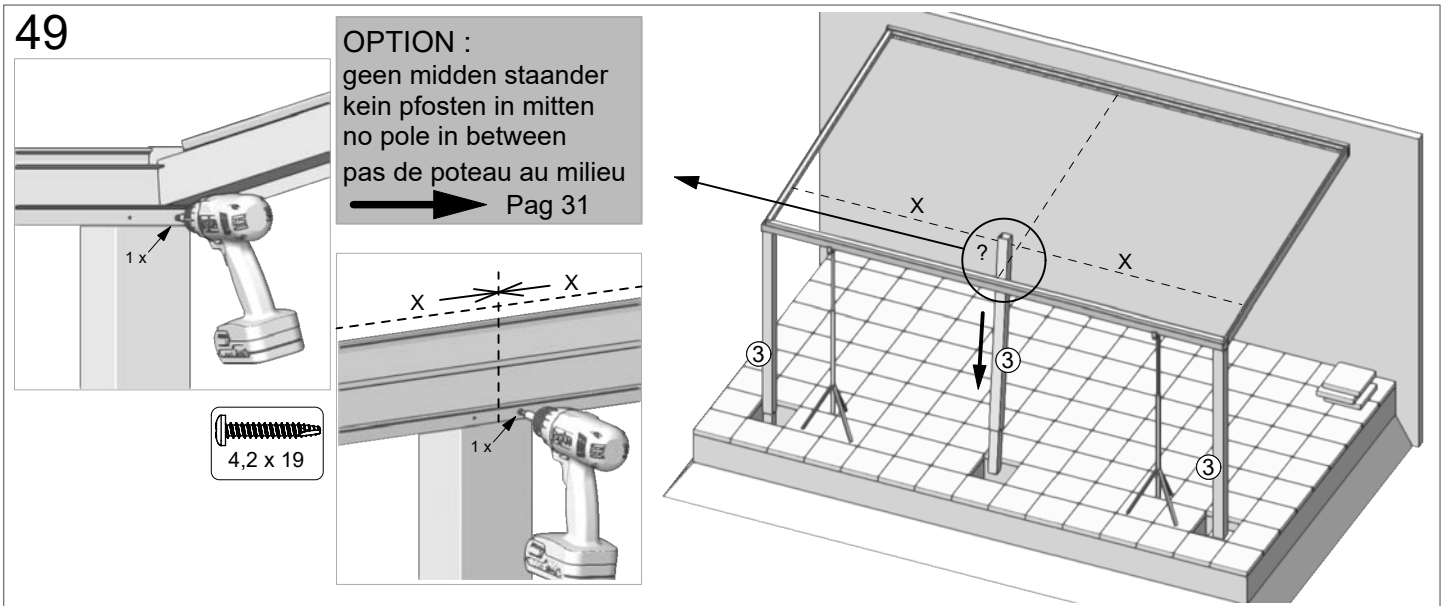
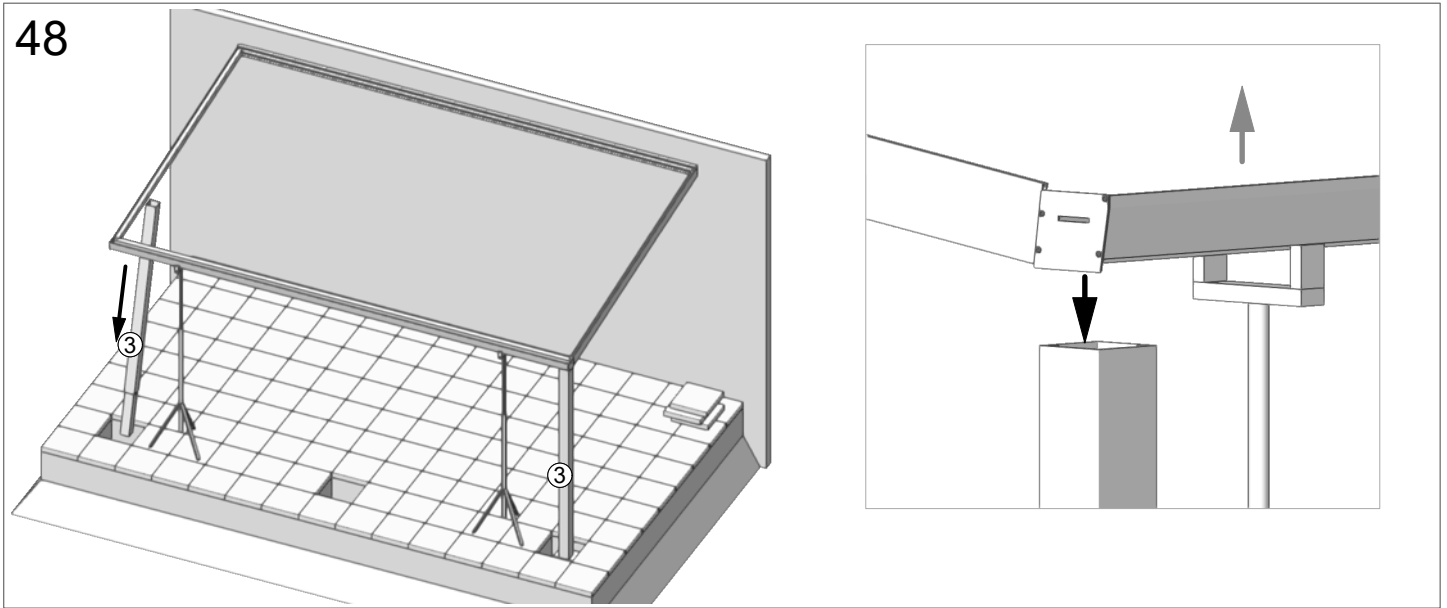

 Montage veranda (standers optie B)  
 Montage Terrassenüberdachung (optie B)

 Assembly roof (poles option B)  
 Montage pergola (option B)



 Montage veranda ( tussenliggers )  
 Montage Terrassenüberdachung

 Assembly roof ( roof beams )  
 Montage pergola ( poutres de toit )

51

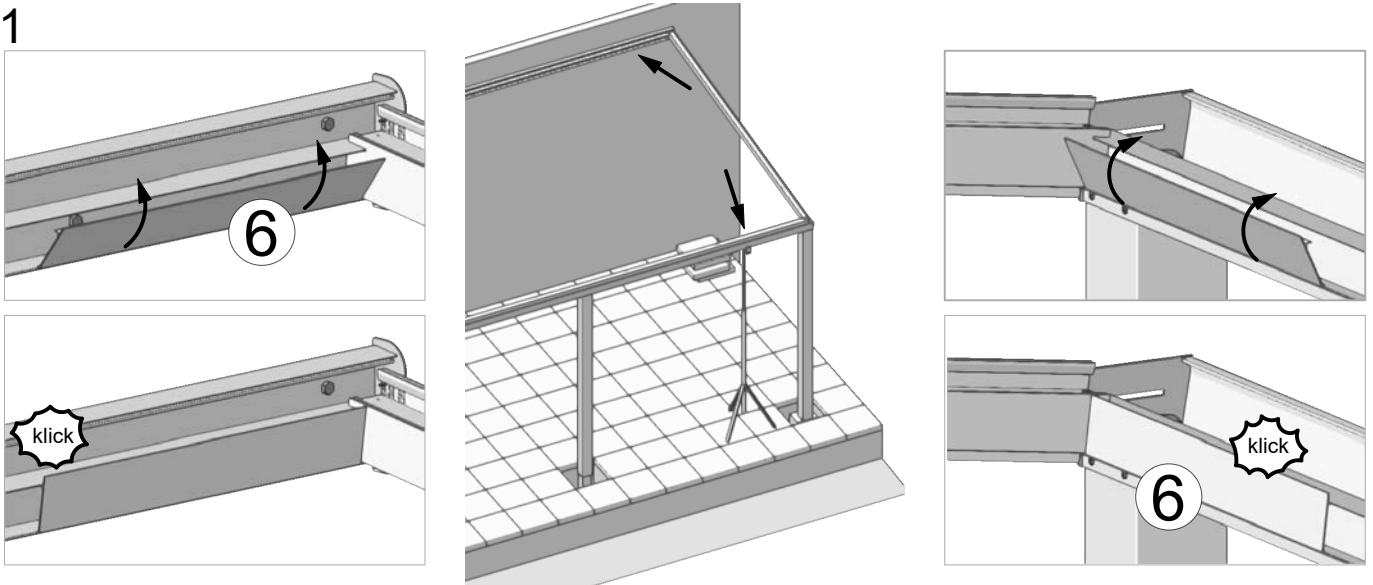

52

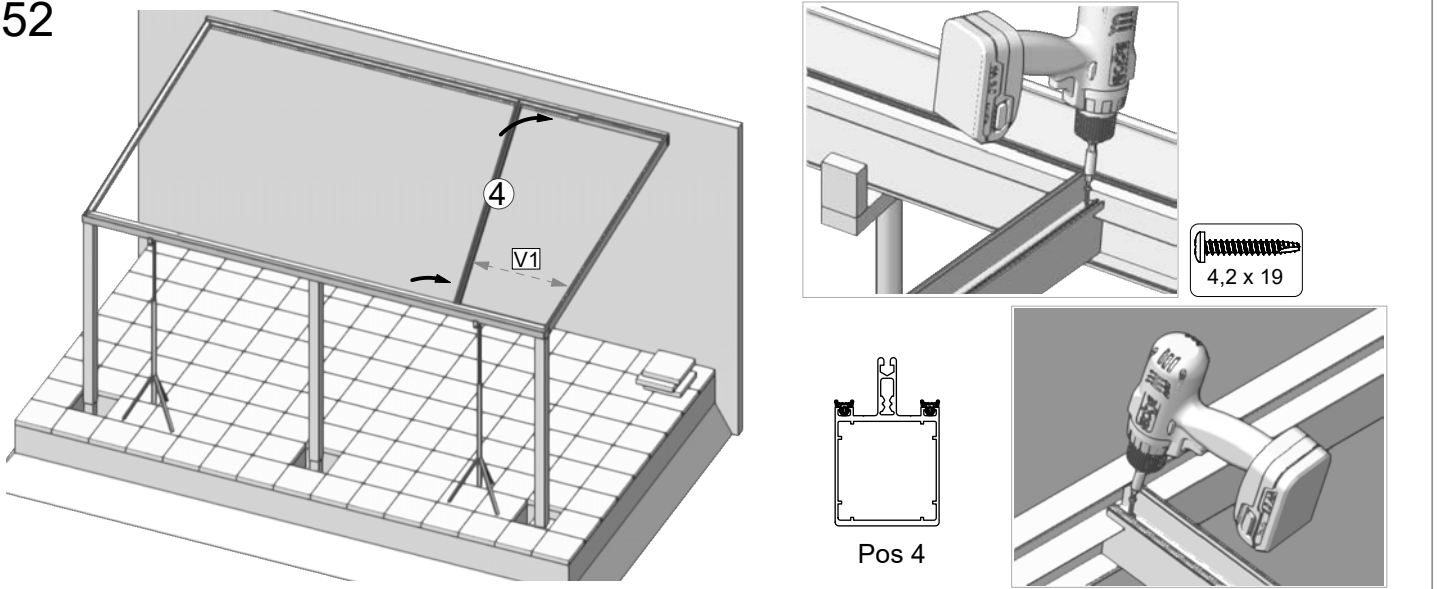

53

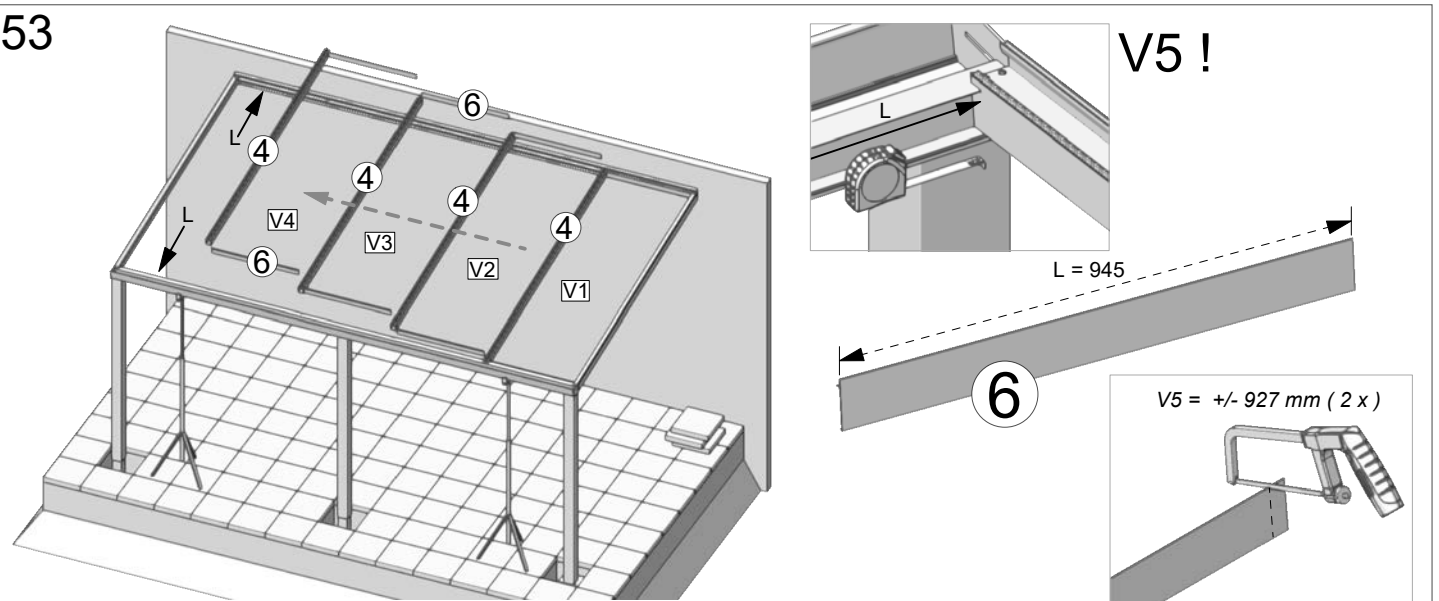



Montage veranda

Montage Terrassenüberdachung



Assembly roof

Montage pergola

54

Aftappen van de Polycarbonaat dakplaten  
Abkleben von die Polycarbonat-platten

Taping the polycarbonate roofing  
Plaques de toiture en polycarbonate

**NICHT BEI VSG**  
**EINDECKUNG**  
**ERFORDERLICH**

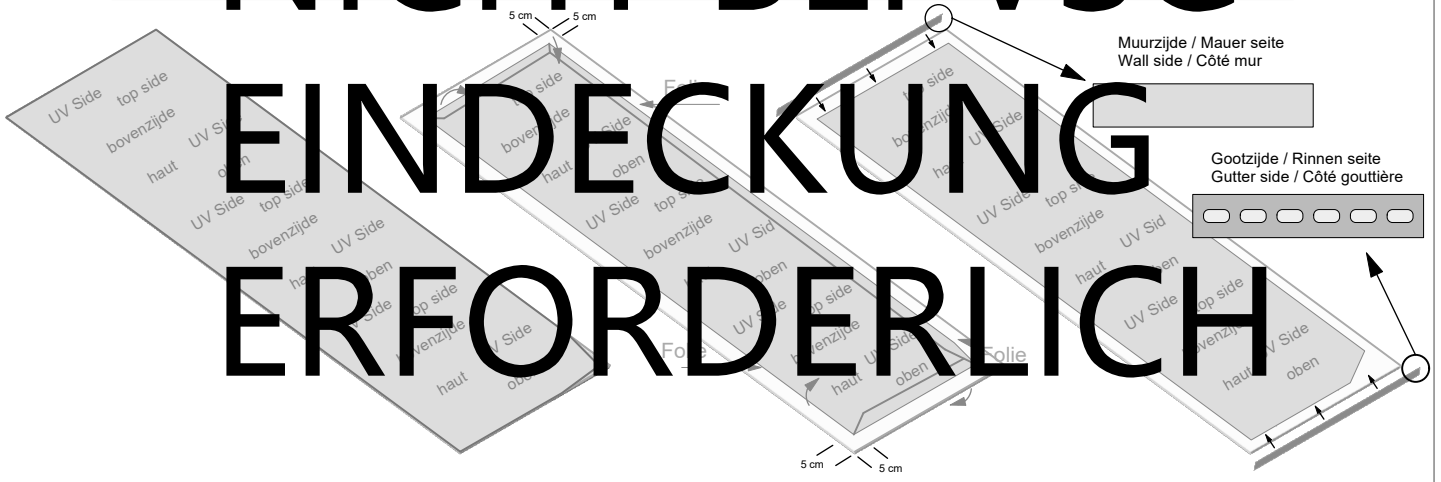

55

**NICHT BEI VSG**  
**EINDECKUNG**  
**ERFORDERLICH**





56

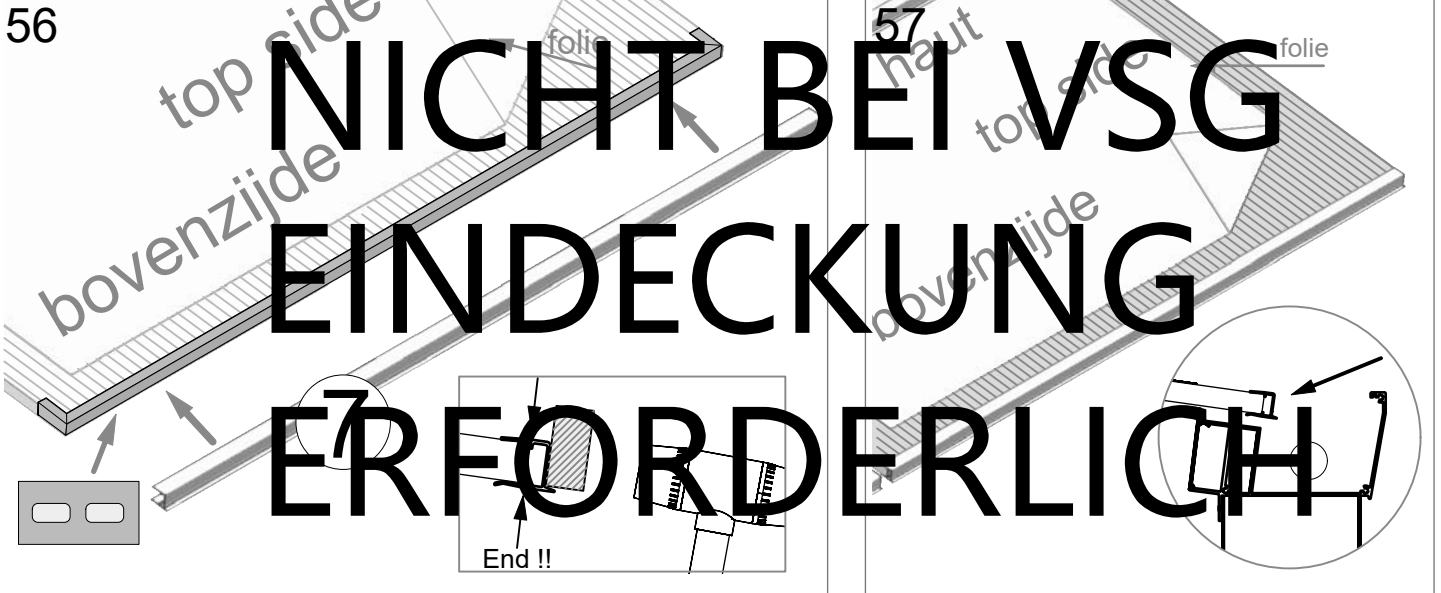

**NICHT BEI VSG**  
**EINDECKUNG**  
**ERFORDERLICH**

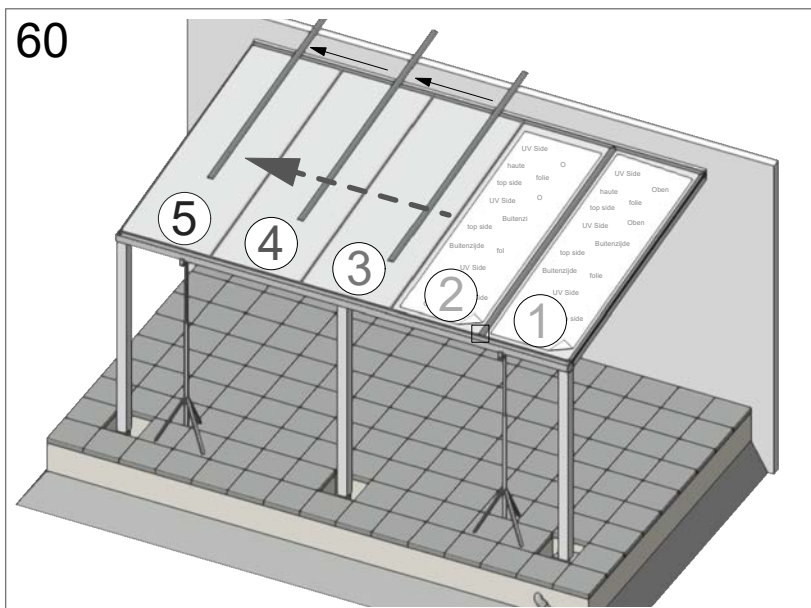
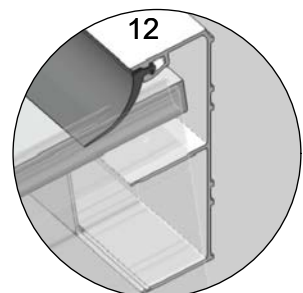
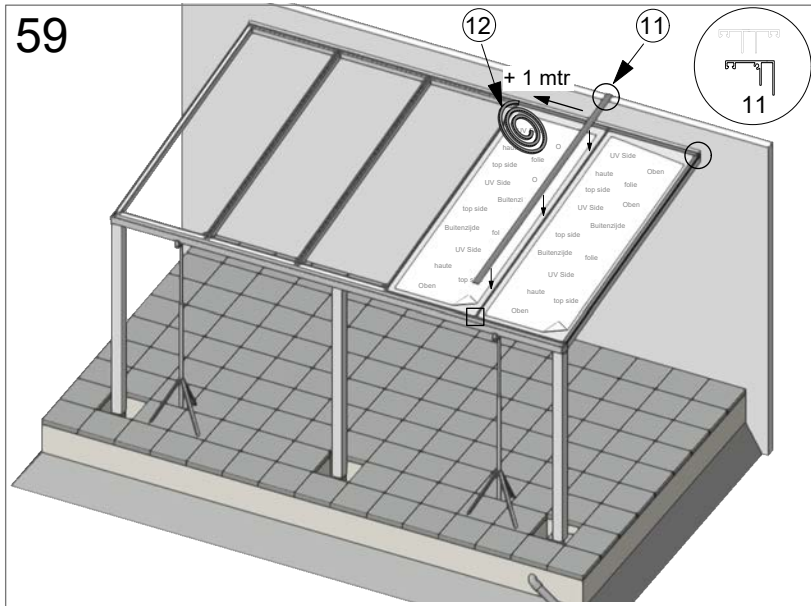
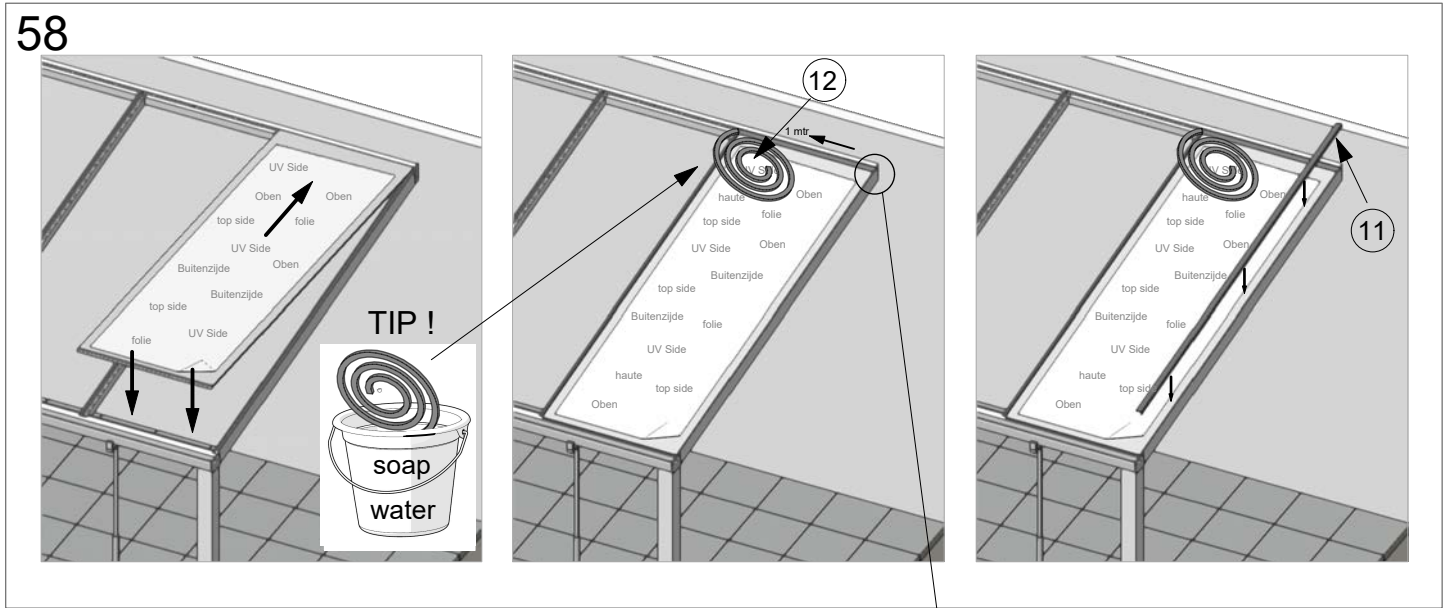

57





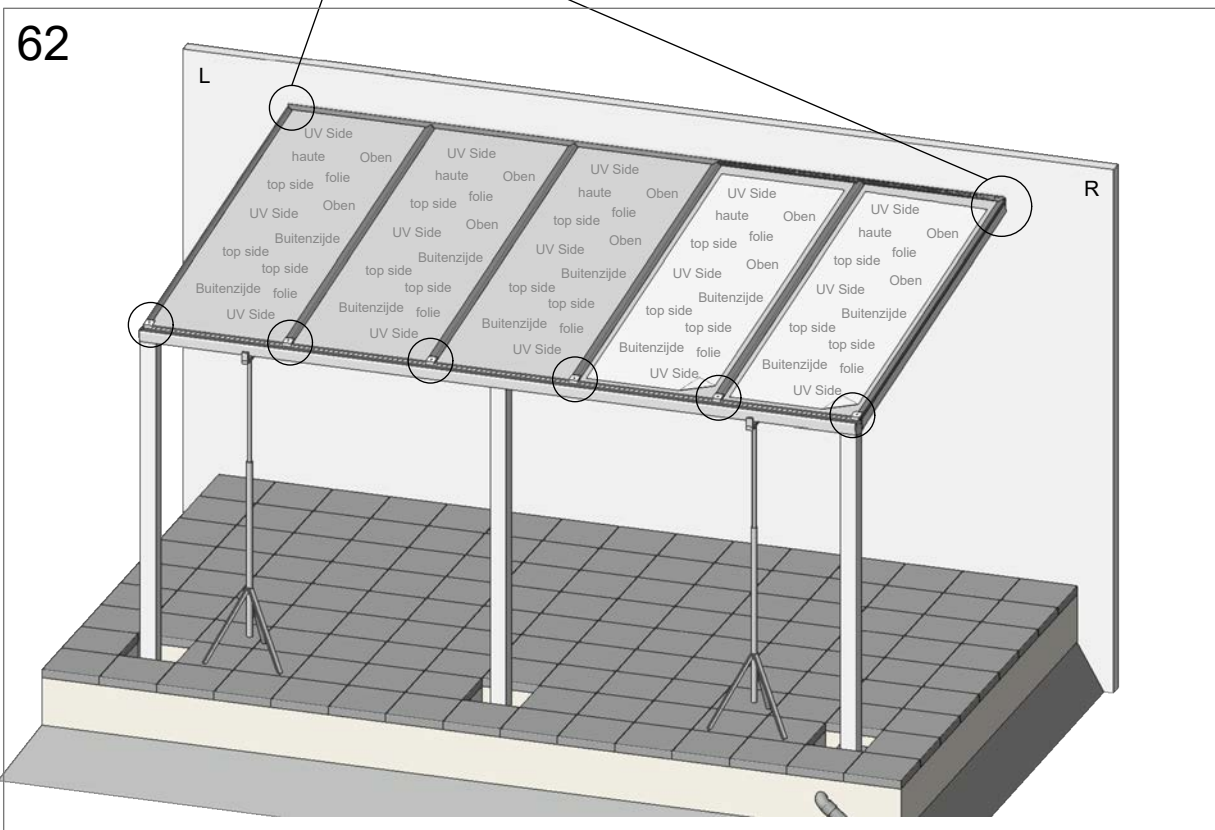
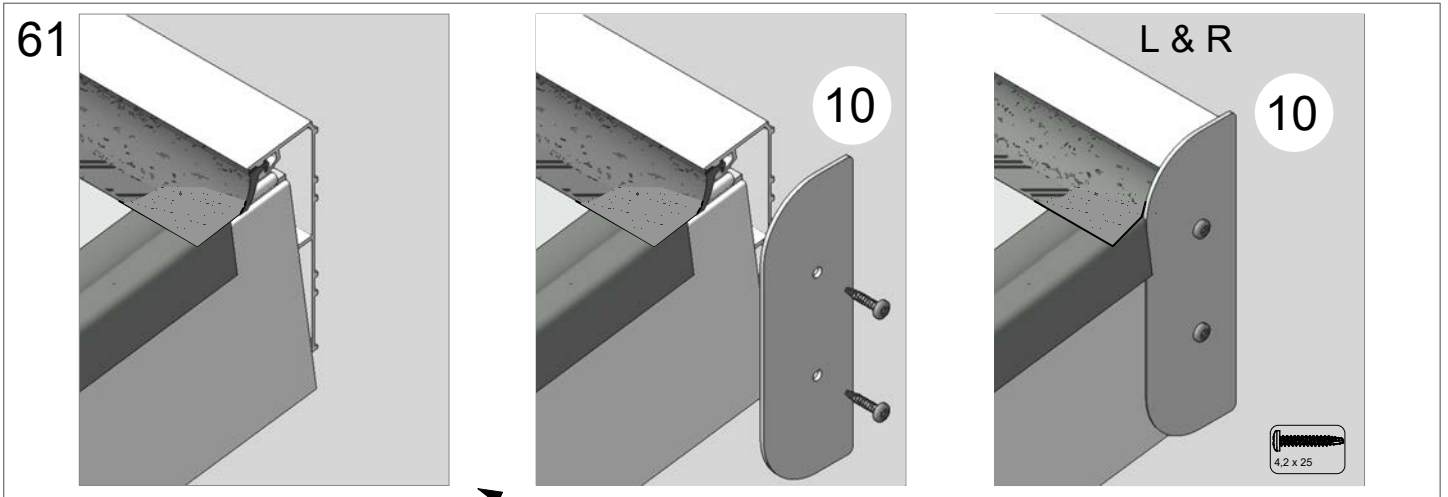

 Montage veranda  
 Montage Terrassenüberdachung

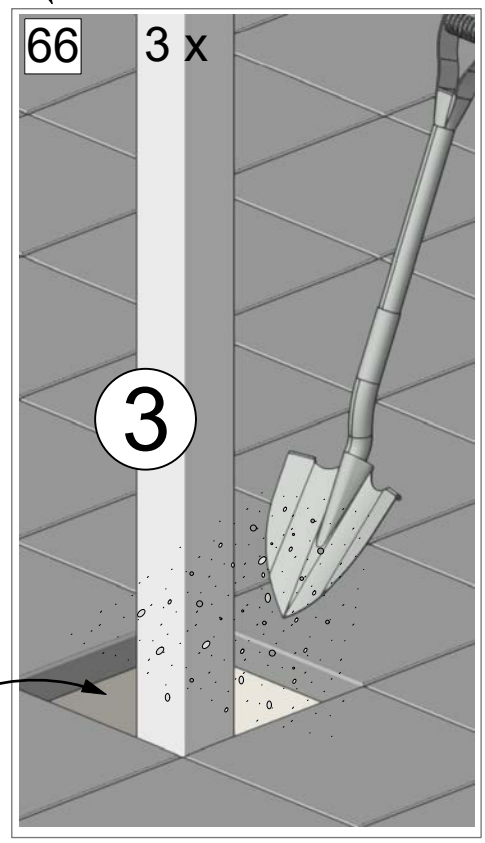
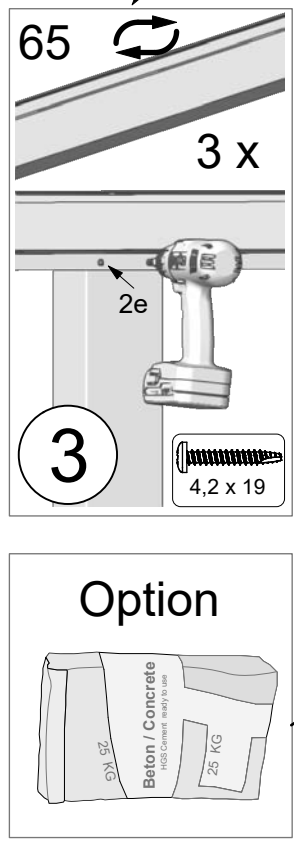
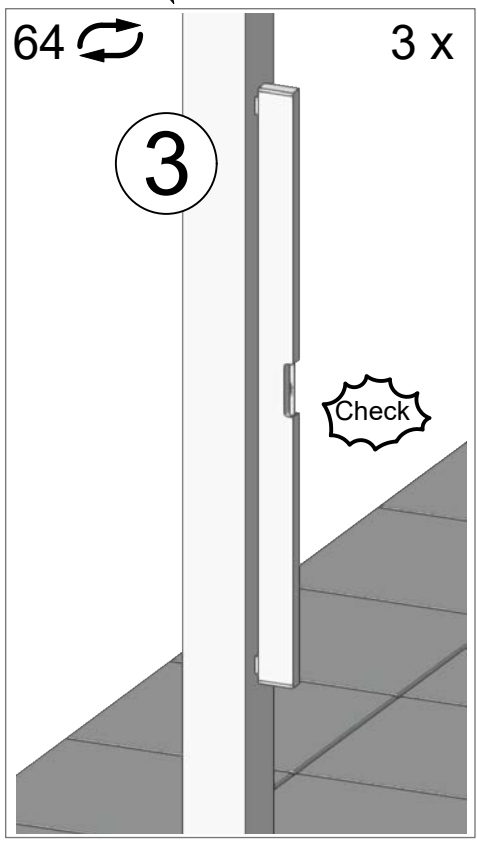
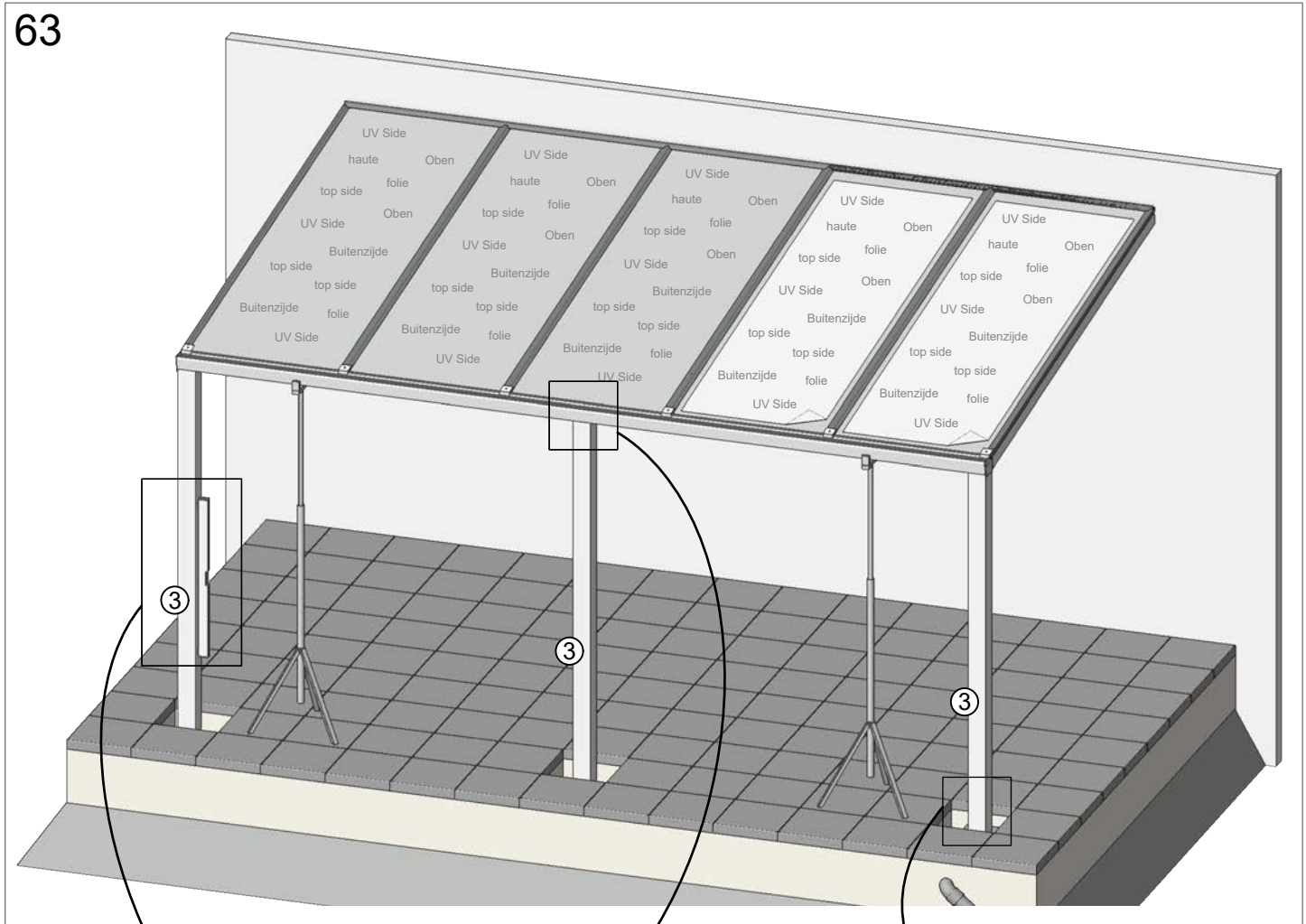
 Assembly roof  
 Montage pergola





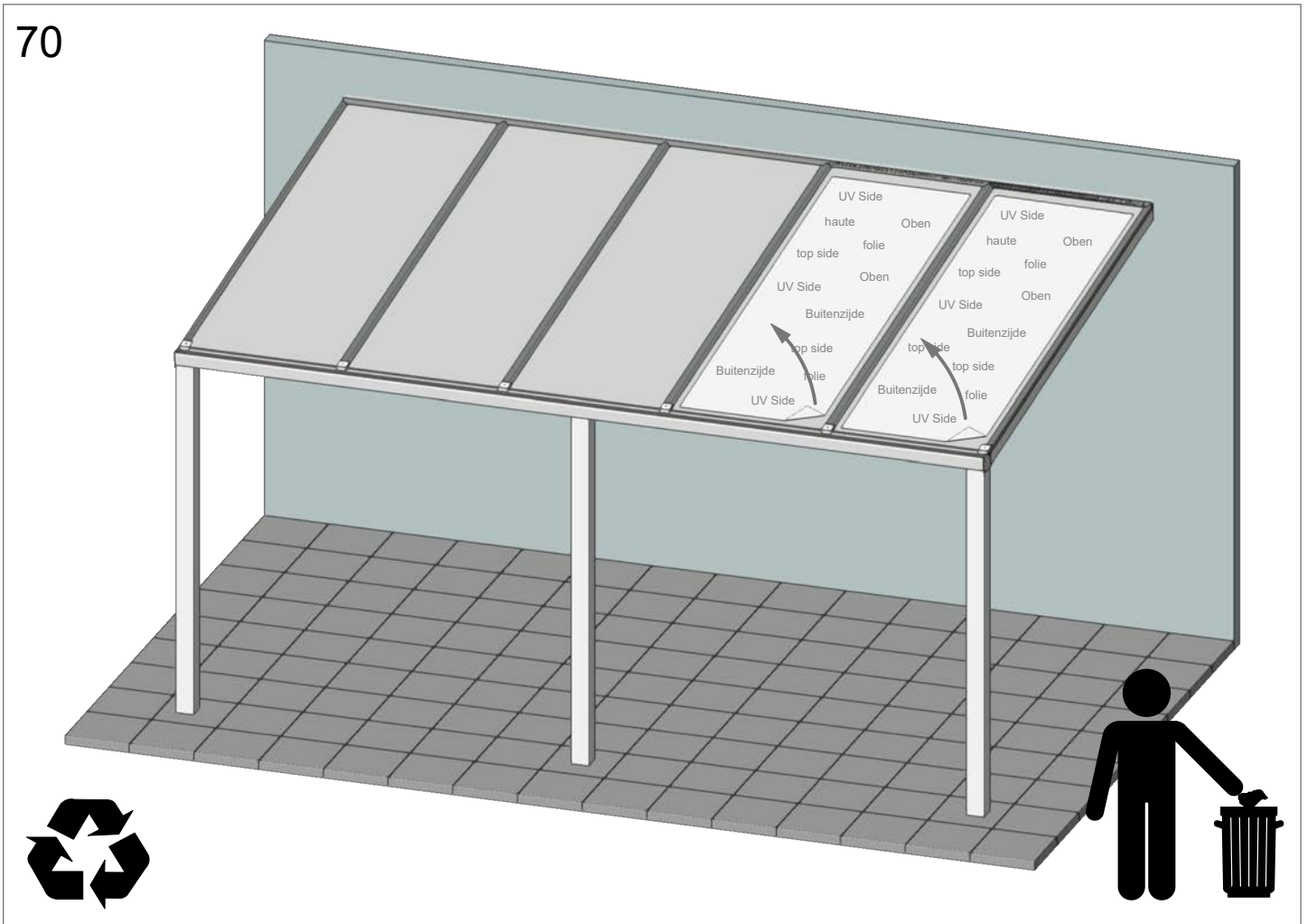
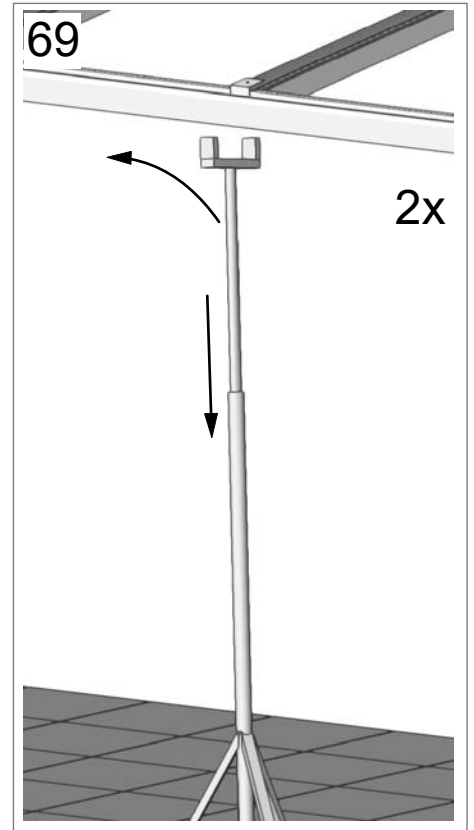
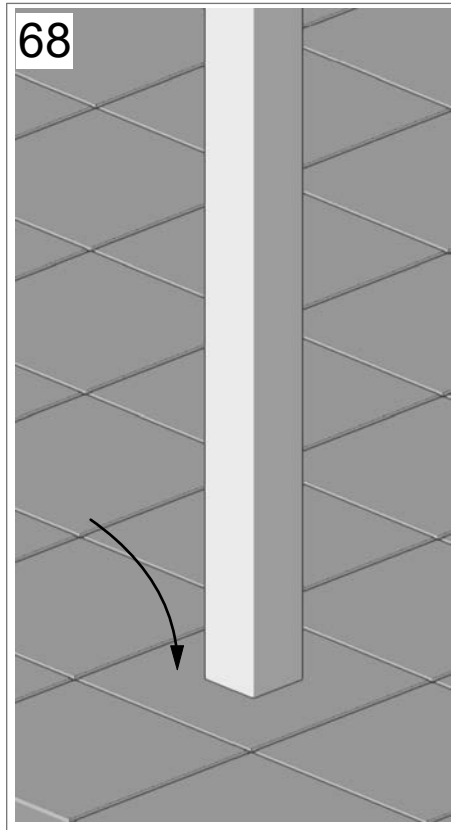
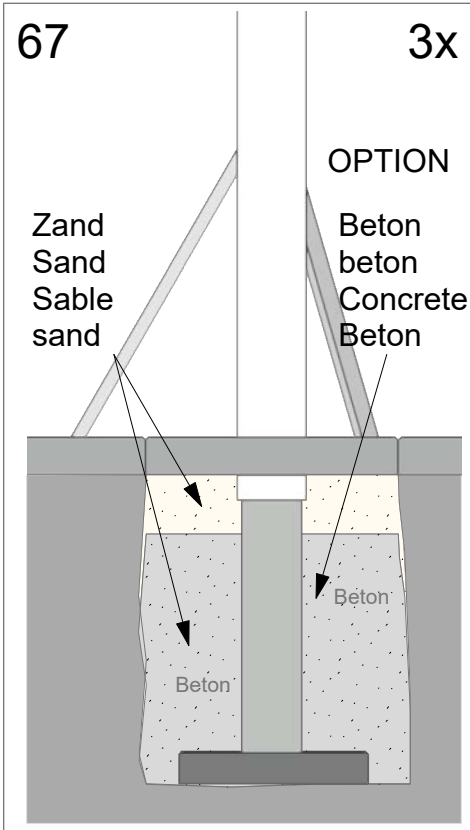

 **Montage veranda**  
 **Montage Terrassenüberdachung**

 **Assembly roof**  
 **Montage pergola**



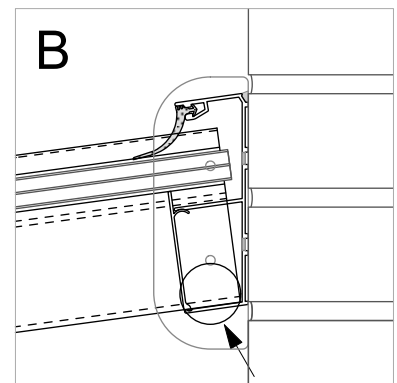
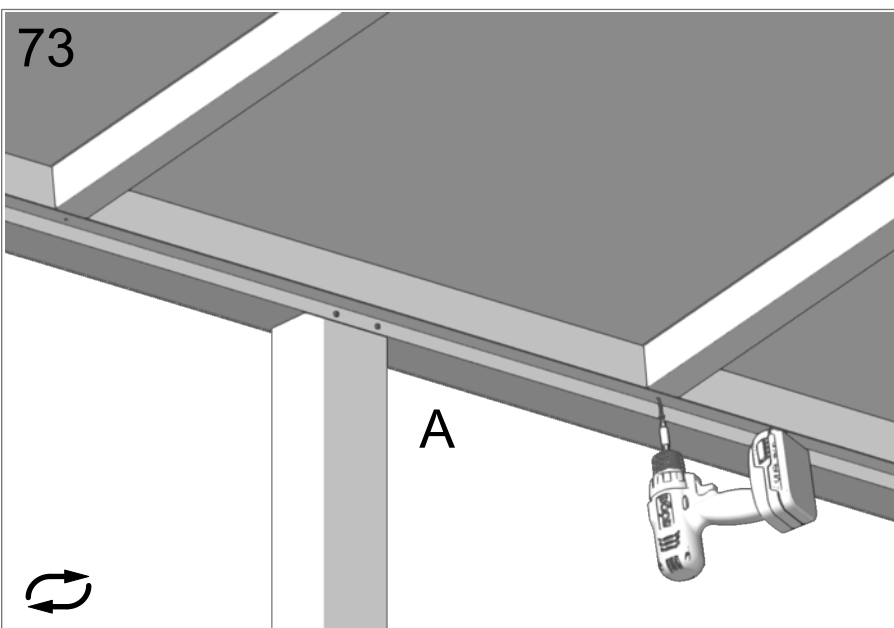
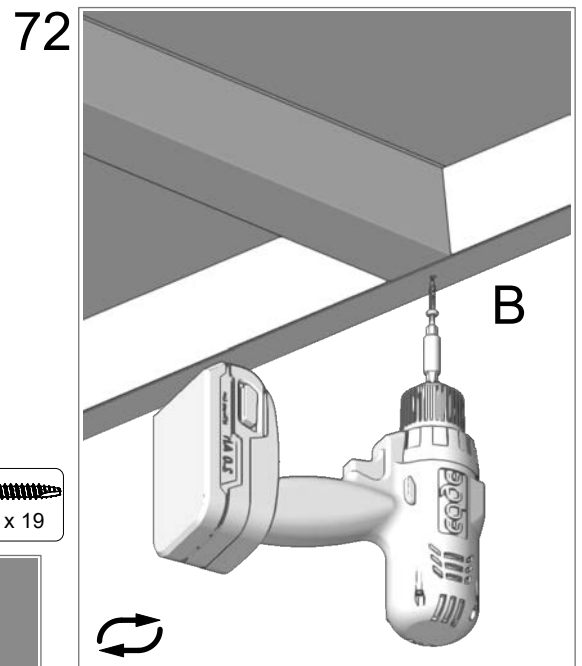
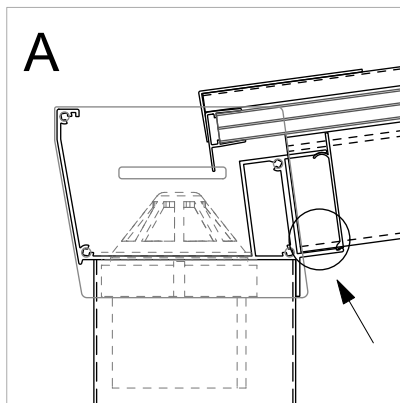
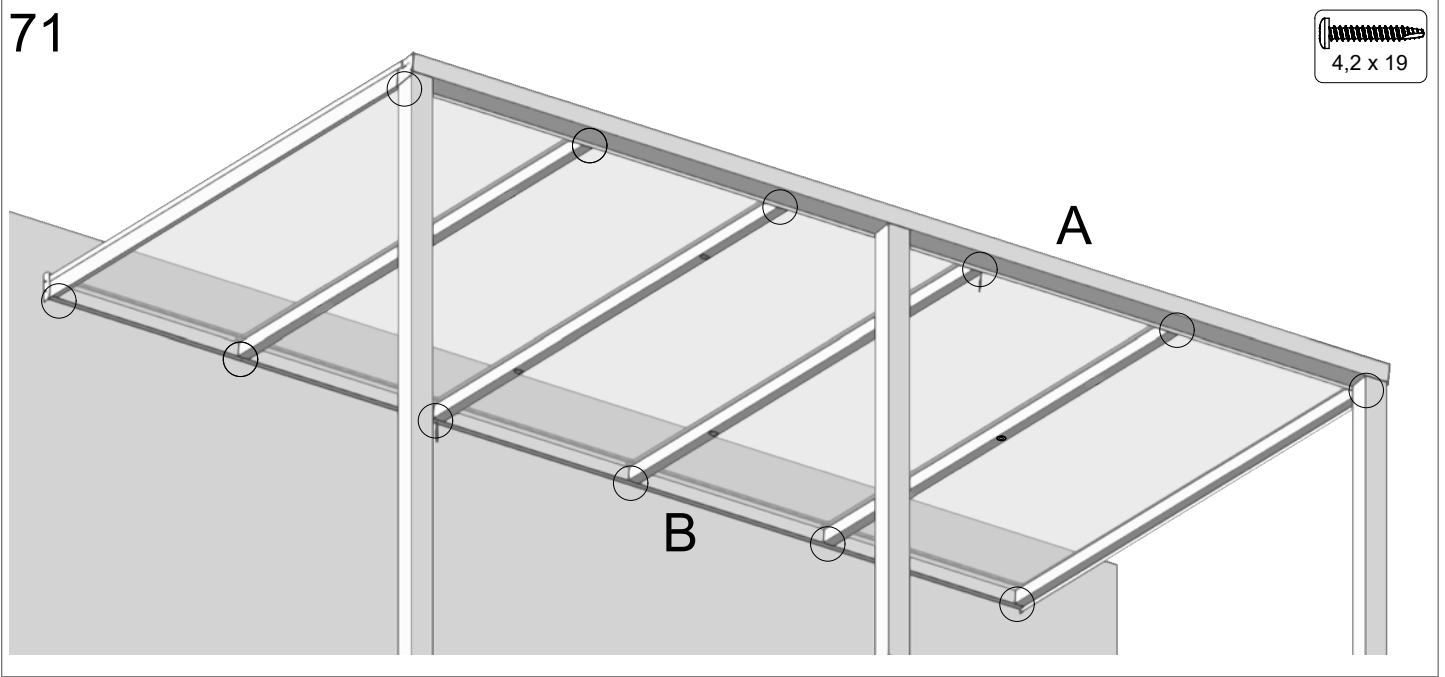

 Montage veranda ( laatste stappen )  
 Montage Terrassenüberdachung

 Assembly roof ( final steps )  
 Montage pergola ( étapes finales )



 Montage veranda ( Option VVK 110 )  
 Montage Terrassenüberdachung

 Assembly roof ( Option VVK 110 )  
 Montage pergola ( Option VVK 110 )

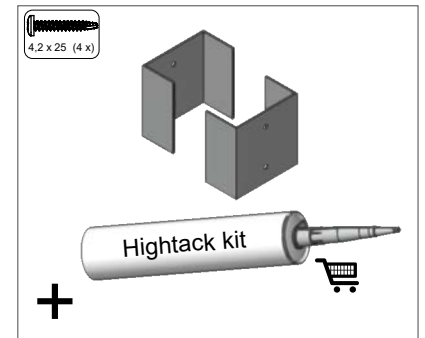
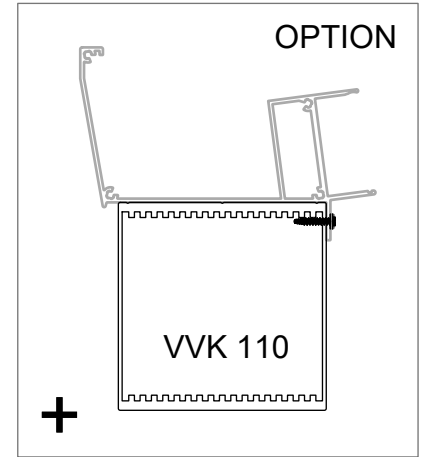
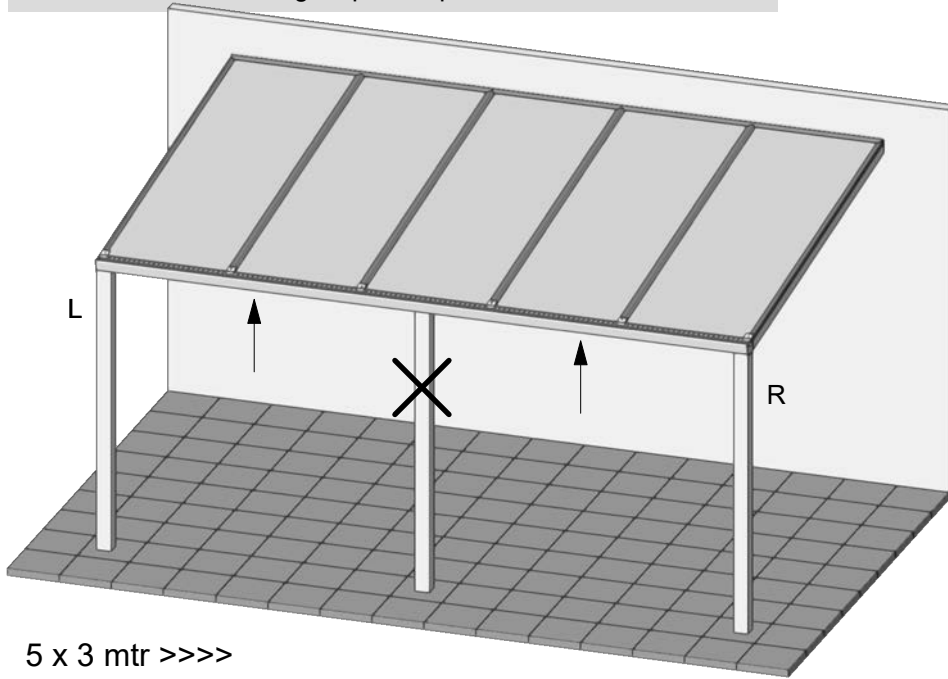

**OPTION:** Veranda zonder midden staander  
 Terrassenüberdachung ohne mitten pfofen  
 Terras roof without middle pole.  
 Pergola pas de poteau au milieu

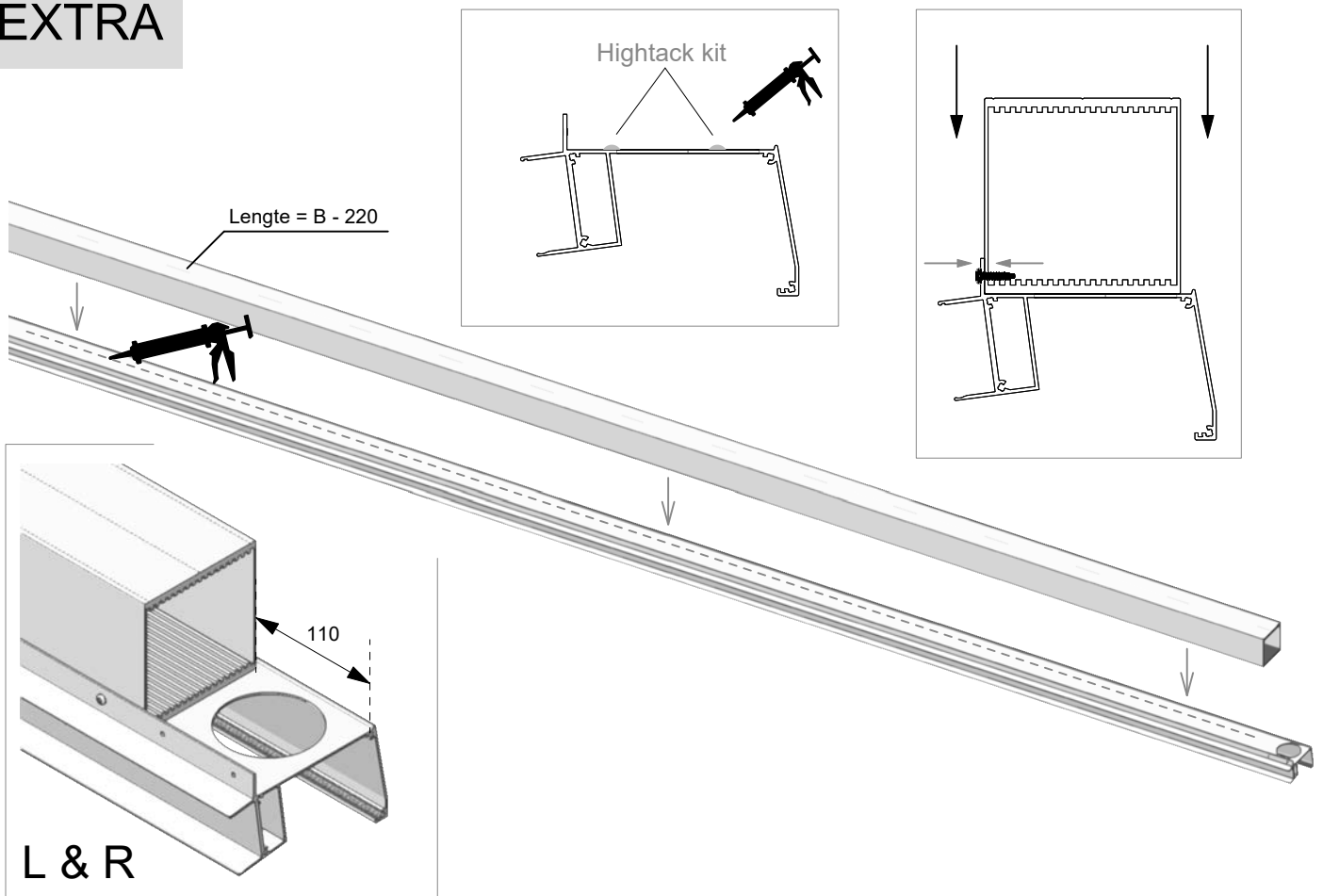

**EXTRA**



 Montage veranda ( Option VVK 110 )  
 Montage Terrassenüberdachung

 Assembly roof ( Option VVK 110 )  
 Montage pergola ( Option VVK 110 )

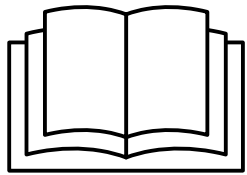
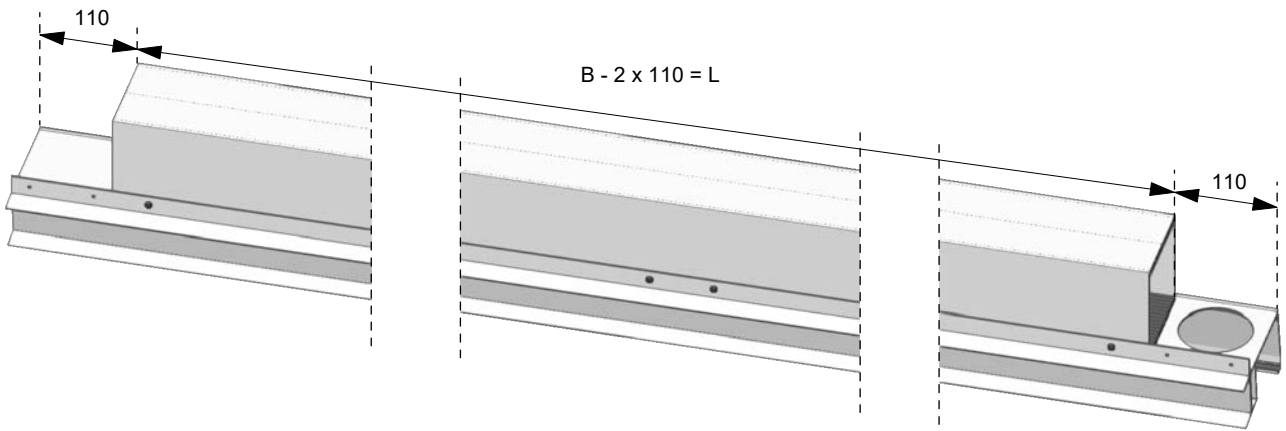

# EXTRA

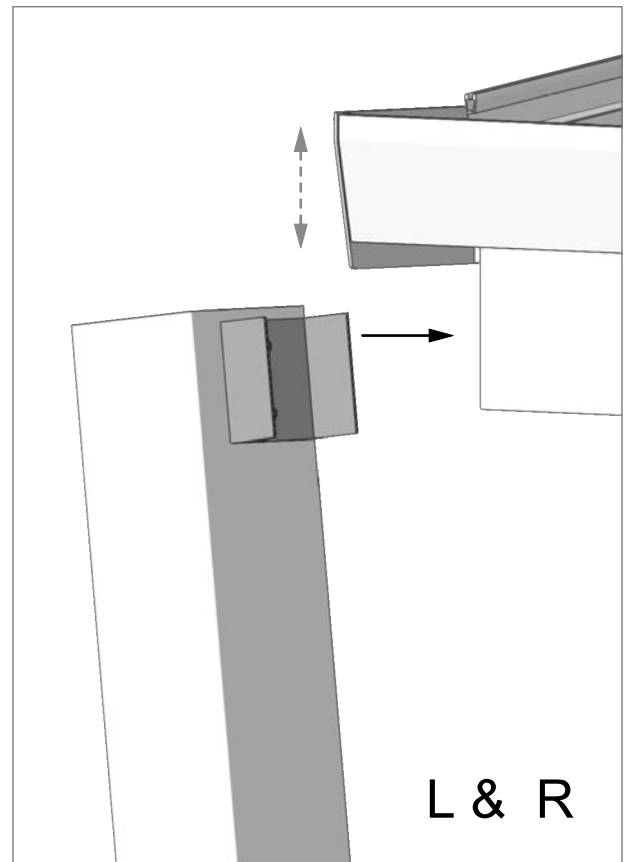
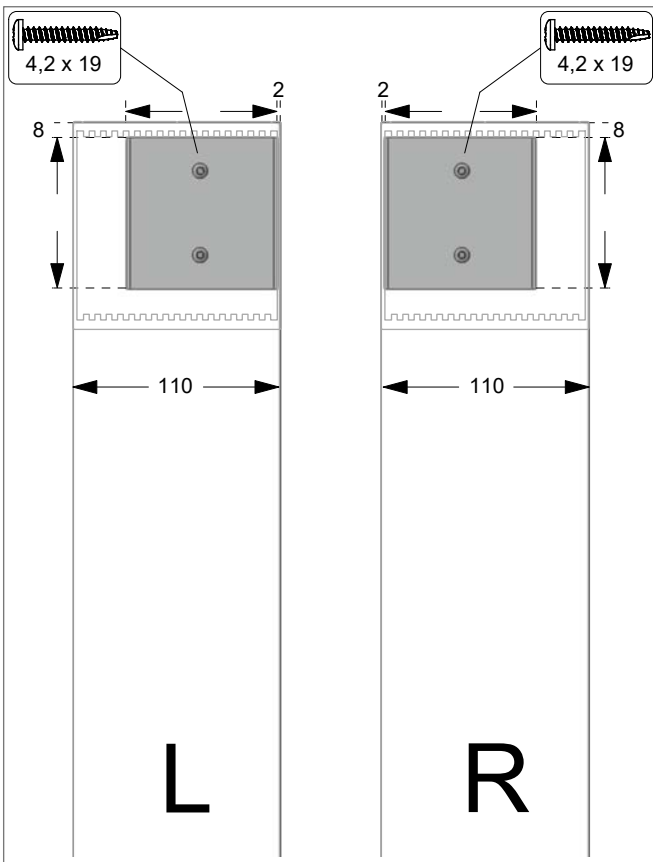
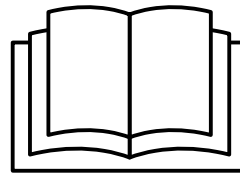

Step 34 / 48



 Montage veranda ( Option VVK 110 )  
 Montage Terrassenüberdachung

 Assembly roof ( Option VVK 110 )  
 Montage pergola ( Option VVK 110 )

# EXTRA

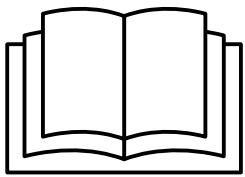
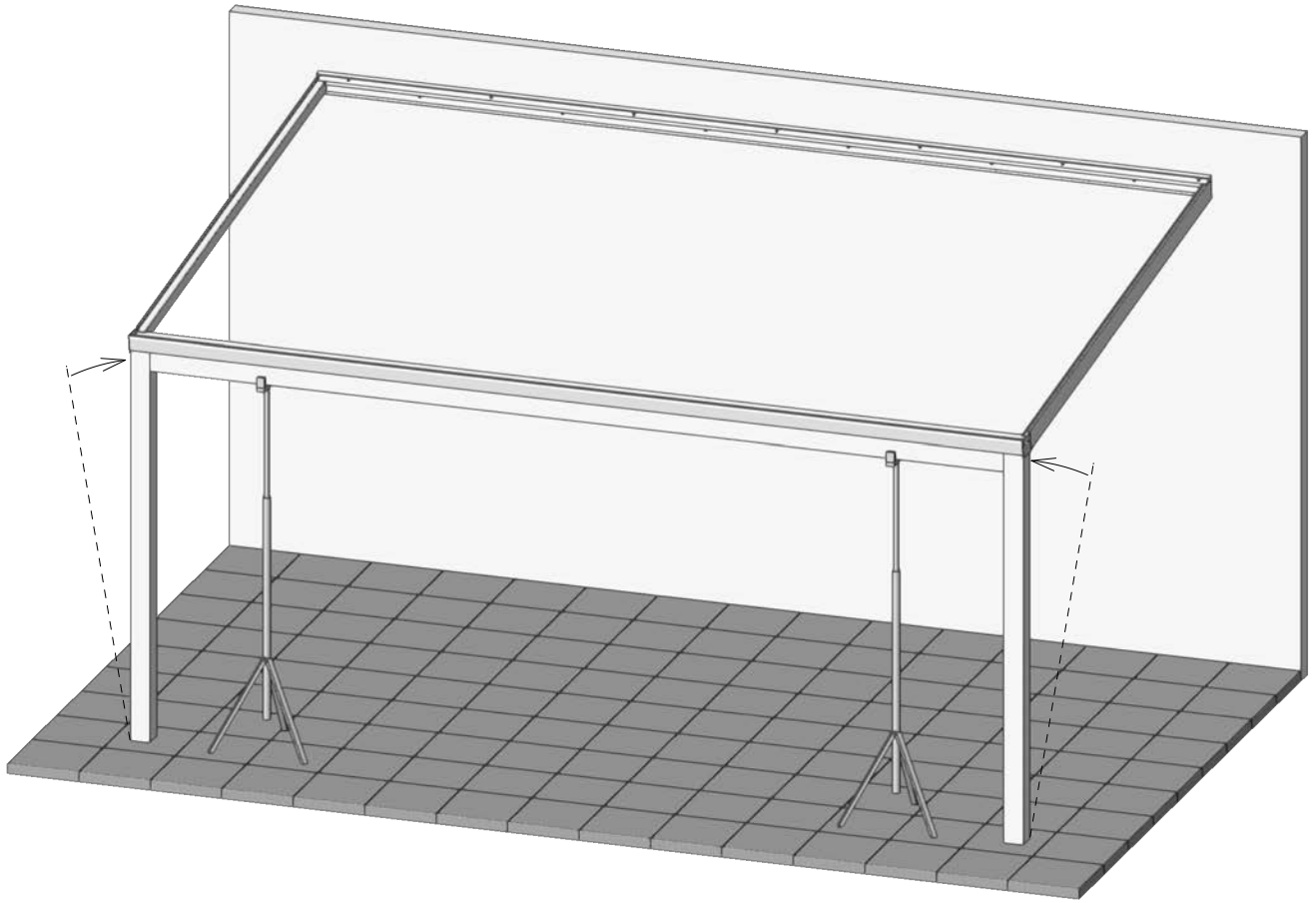

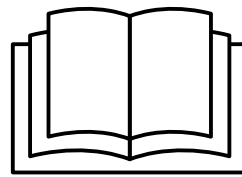

Step 34 / 48



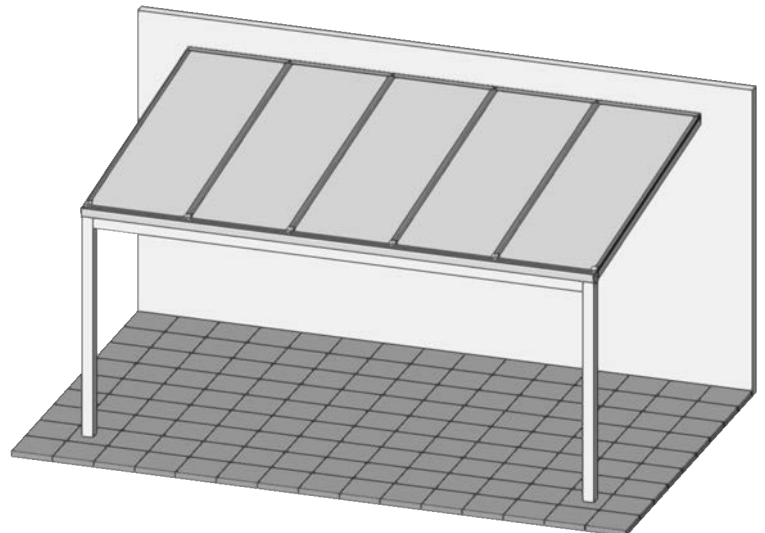



Step 50

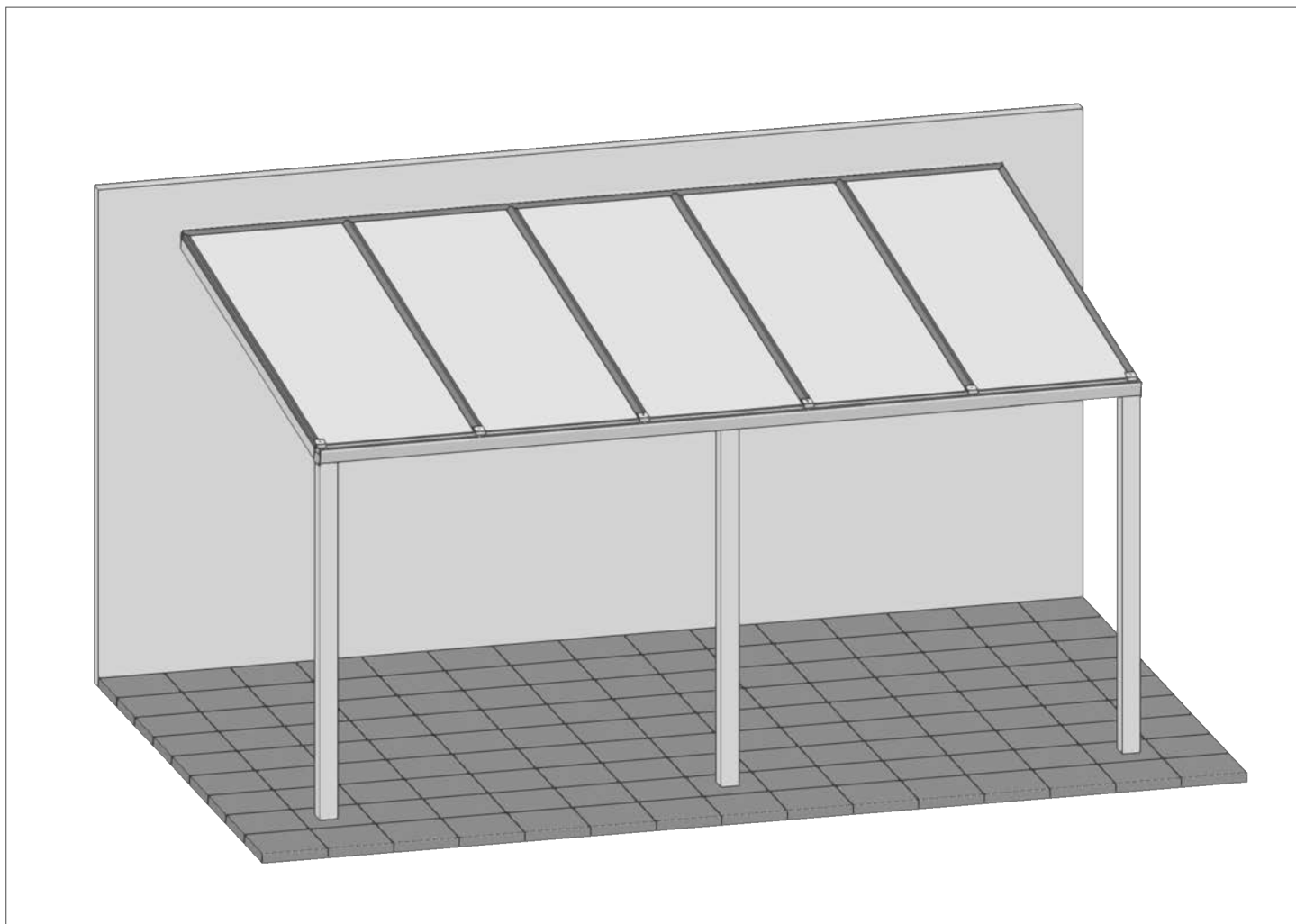

-  Montage veranda
-  Montage Terrassenüberdachung

-  Assembly roof
-  Montage pergola



-  Uw Greenline veranda is gereed, veel plezier met uw produkt !
-  Fertig ist Ihre Greenline-Veranda, viel Spaß mit Ihrem Produkt !
-  Your Greenline veranda is ready, have fun with your product !
-  Votre véranda Greenline est prête, amusez-vous avec votre produit !