

DE Montageanleitung

NL Montagehandleiding

EN Mounting instruction

CS Návod k instalaci

ES Instrucciones de instalación

PL Instrukcja montażu

FR Instructions d'installation

RU Инструкция по монтажу

IT Istruzioni per l'installazione

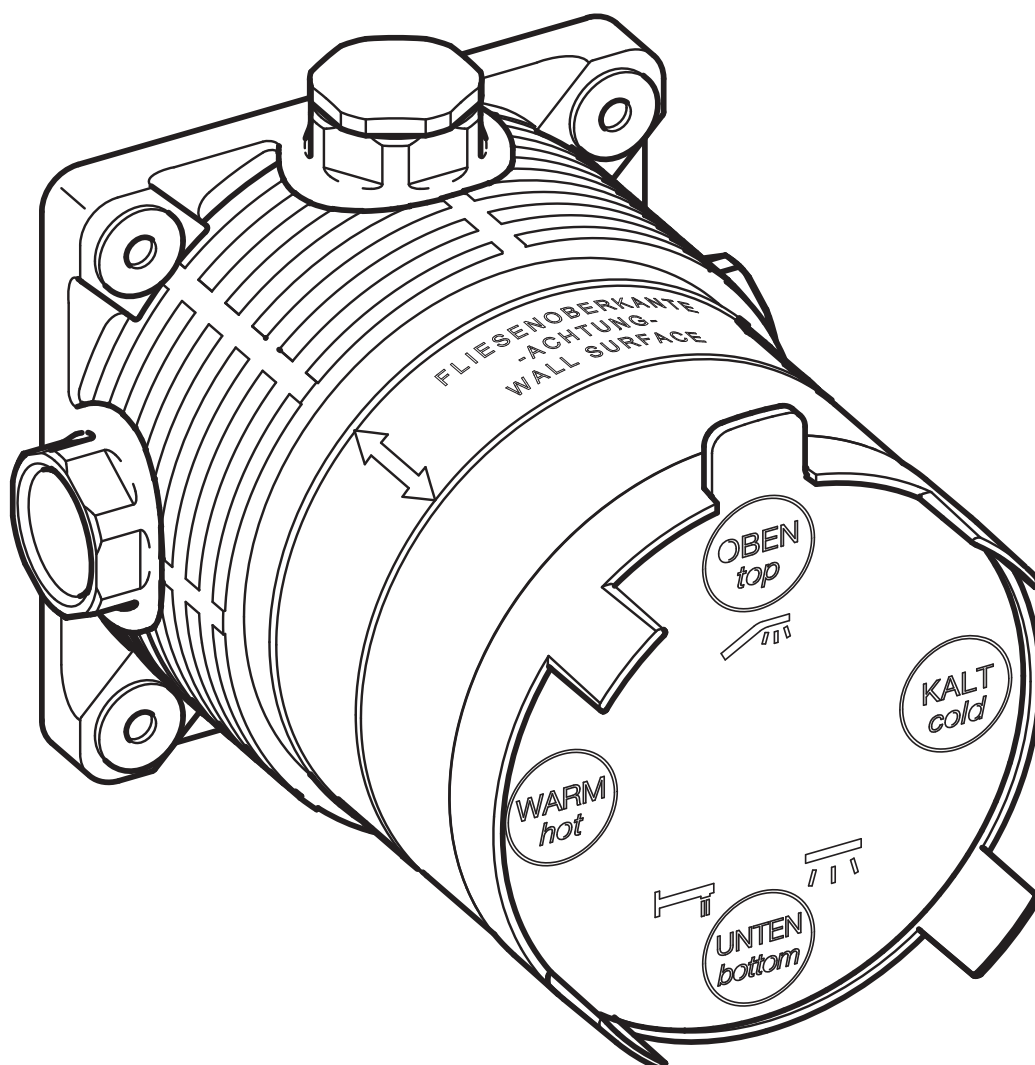

59970 000070

DE Einbaumaße

FR Dimensions de montage

CS Montážní rozměry

EN Mounting dimensions

IT Dimensioni di montaggio

PL Wymiary montażowe

ES Dimensiones de montaje

NL Montageafmetingen

RU Установочные размеры

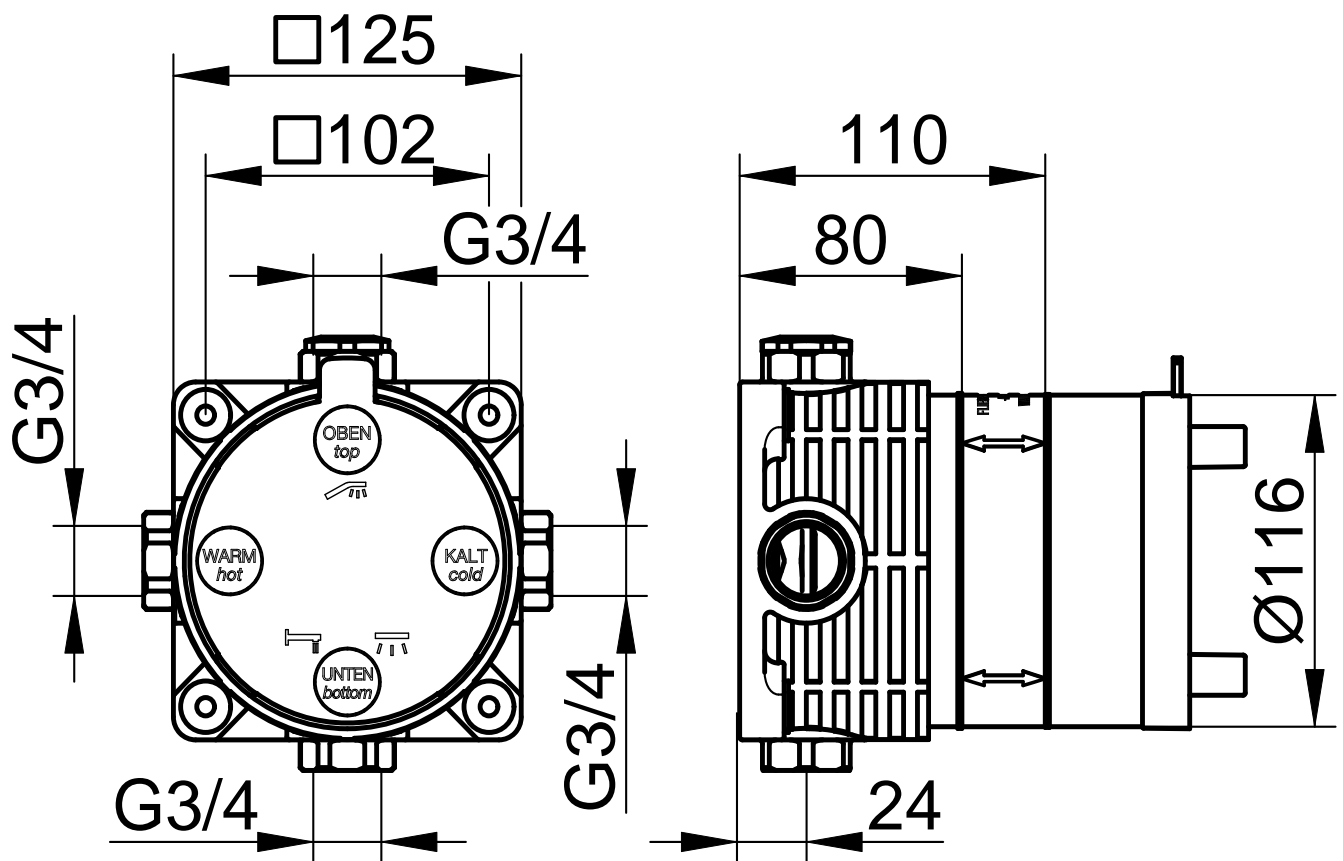

59970 000070

Symbole und Bedeutung





-  **Achtung!** Warnung vor Personen- oder Sachschaden.
-  **Achtung!** Warnung vor Stromschlag.
-  **Achtung!** Warnung vor Wasserschaden.
-  Hinweis, Tipp oder Verweis
-  Korrekte Montage/Funktionsprüfung
-  Falsche Montage
-  Kaltwasser
-  Warmwasser
-  Wasserfluss
-  Kein Wasserfluss
-  Optional/Zubehör

Technische Daten

- Fließdruck: min. 0,5 bar/empfohlen 1-5 bar
- Betriebsdruck: max. 10 bar
- Prüfdruck: 16 bar
- Empfohlene Warmwassereingangstemperatur: max. 65° C
- Wasseranschluss: kalt = Kennzeichnung blau
warm = Kennzeichnung rot











Einbaumaße, siehe Seite 2

Installation, siehe ab Bild 1a auf Seite 8 oder ab Bild 1b auf Seite 12 oder ab Bild 1c auf Seite 15

-  Trinkwasserleitungen vor und nach der Installation gründlich spülen (EN 806 und 1717 sowie DIN 1988 beachten).
Anschlüsse mit hydraulischem Druck auf Dichtheit prüfen.
-  Betrieb nur mit Wasser in Trinkwasserqualität.
-  Produkt ausschließlich zur Montage in Innenräumen geeignet!
-  **Achtung!** Installation nur in frostfreien Räumen.

Ersatzteile mit Bestellnummern, siehe Seite 19.

Symbols and explanations

-  **Attention!** Warning against bodily injury or damage to property.
-  **Attention** Warning against electric shock.
-  **Attention!** Warning against water damage.
-  Note, tip or reference
-  Correct installation/test of functionality
-  Incorrect installation
-  Cold water
-  Hot water
-  Water flow
-  No water flow
-  Optional/accessories



Technical specifications

- Pressure: min. 0,5 bar/recommended 1-5 bar
- Operating pressure: max. 10 bar
- Test pressure: 16 bar
- Recommended hot water inlet temperature: max. 65° C
- Water connection: cold = blue marking
hot = red marking

Installation dimensions, refer to page 2











Installation, refer to picture 1a on page 8 or picture 1b on page 12 or picture 1c on page 15

-  Flush potable water pipes thoroughly before and after installation (observe EN 806 and 1717).

Test connections for leaks with water pressure.
-  Operation only with potable water.
-  Product is only suitable for installation indoors!
-  **Attention!** Only install in frost-free places.

For spare parts with order numbers, refer to page 19.

Símbolos y significado





-  ¡Atención! Advertencia de daños personales o materiales.
-  ¡Atención! Advertencia de descarga eléctrica.
-  ¡Atención! Advertencia de daños a causa del agua.
-  Indicación, consejo o referencia
-  Montaje/comprobación de funcionamiento correctos
-  Montaje erróneo
-  Agua fría
-  Agua caliente
-  Flujo de agua
-  Ningún flujo de agua
-  Opcional/Accesorios

Datos técnicos

- Presión de caudal:
mín. 0,5 bares / recomendado 1-5 bares
- Presión de servicio: máx. 10 bares
- Presión de comprobación: 16 bares
- Temperatura de entrada de agua
recomendada: máx. 65° C
- Conexión de agua:
fría = identificación azul
caliente = identificación roja











Medidas de montaje, véase página 2

Instalación, véase imagen 1a en la página 8 o de la imagen 1b en la página 12 o de la imagen 1c en la página 15

-  Lavar minuciosamente las tuberías de agua potable antes y después de la instalación (observar EN 806 y 1717).
Comprobar la estanqueidad de las conexiones con presión hidráulica.
-  Funcionamiento sólo con agua en calidad de agua potable.
-  ¡Producto adecuado exclusivamente para el montaje en interiores!
-  ¡Atención! Instalación exclusivamente en espacios sin riesgo de heladas.

Piezas de recambio con números de pedido, véase página 19.

Symboles et leur signification





-  **Attention !** Mise en garde contre les dégâts de personnes et les dégâts matériels.
-  **Attention !** Mise en garde contre les chocs électriques.
-  **Attention !** Mise en garde contre les endommagements par l'eau.
-  Remarque, conseil ou renvoi
-  Montage correct/contrôle fonctionnel
-  Montage incorrect
-  Eau froide
-  Eau chaude
-  Débit d'eau
-  Pas de débit d'eau
-  Option/accessoires

Caractéristiques techniques

- Pression d'écoulement :
min. 0,5 bar/pression conseillée 1-5 bar
- Pression de service : max. 10 bar
- Pression de contrôle : 16 bar
- Température d'entrée d'eau chaude conseillée :
max. 65° C
- Raccordement d'eau :
froide = identification en bleu
chaude = identification en rouge







Cotes d'encombrement, voir page 2

Installation, voir figure 1a à la page 8 ou à partir de l'image 1b à la page 12 ou à partir de l'image 1c à la page 15

-  Rincer soigneusement les conduites d'eau potable avant et après l'installation (respecter les normes EN 806 et 1717).
Vérifier l'étanchéité des raccords à la pression hydraulique.
-  Utilisation seulement avec eau de qualité eau potable.
-  Le produit ne convient que pour un montage à l'intérieur !
-  **Attention !** Installation uniquement dans des pièces à l'abri du gel.

Pièces de rechange avec numéros de commande, voir page 19.

Simboli e significato





-  **Attenzione!** Pericolo di lesioni o danni materiali.
-  **Attenzione!** Pericolo di folgorazione.
-  **Attenzione!** Pericolo di danni causati dall'acqua.
-  Avvertenza, consiglio o rimando
-  Montaggio corretto/verifica del funzionamento
-  Montaggio errato
-  Acqua fredda
-  Acqua calda
-  Flusso d'acqua
-  Nessun flusso d'acqua
-  Opzionale/accessorio

Dati tecnici

- Pressione di flusso:
min. 0,5 bar/raccomandati 1-5 bar
- Pressione di esercizio: max. 10 bar
- Pressione di prova: 16 bar
- Temperatura d'ingresso dell'acqua calda consigliata: max. 65°C
- Collegamento dell'acqua:
fredda = marcatura blu
calda = marcatura rossa

Ingombro, vedi pagina 2

Installazione, vedi dalla figura 1a a pagina 8 o dall'immagine 1b a pagina 12 o dall'immagine 1c a pagina 15

-  Prima e dopo l'installazione lavare con acqua abbondante le condotte di acqua potabile (osservare EN 806 e 1717).
Verificare la tenuta degli attacchi con pressione idraulica.
-  Funzionamento solo con acqua potabile.
-  Prodotto adatto esclusivamente per il montaggio in ambienti interni!
-  **Attenzione!** Installazione solo in ambienti in assenza di gelo.

Ricambi con numero d'ordine, vedi pagina 19.

Symbolen en betekenis





-  **Opgepast!** Gevaar voor letsel of schade.
-  **Opgepast!** Gevaar voor elektrische schok.
-  **Opgepast!** Gevaar voor waterschade.
-  Opmerking, tip of referentie
-  Correcte montage/werkingstest
-  Verkeerde montage
-  Koud water
-  Heet water
-  Waterstroom
-  Geen waterstroom
-  Optioneel/toebehoren

Technische gegevens

- Stromingsdruk: min. 0,5 bar/aanbevolen 1-5 bar
- Bedrijfsdruk: max. 10 bar
- Testdruk: 16 bar
- Aanbevolen ingangstemperatuur heet water max. 65° C
- Wateraansluiting:
koud = markering blauw
heet = markering rood











Inbouwafmetingen, zie pagina 2

Installatie, zie vanaf afbeelding 1 op pagina 8 of uit afbeelding 1b op pagina 12 of uit afbeelding 1c op pagina 15

-  Drinkwaterleidingen voor en na de installatie grondig spoelen (volgens EN 806 en 1717).
Aansluitingen met hydraulische druk controleren op lektheid.
-  Gebruik uitsluitend met water van drinkwaterkwaliteit.
-  Het product mag alleen binnenshuis worden gemonteerd!
-  **Opgepast!** Installatie alleen in vorstvrije ruimten.

Wisselstukken met bestelnummers, zie pagina 19.

Symbole a význam

-  **Pozor!** Výstraha před zraněním a věcnými škodami.
-  **Pozor!** Výstraha před úrazem elektrickým proudem.
-  **Pozor!** Výstraha před poškozením vodou.
-  Upozornění, tip nebo odkaz
-  Správná montáž / kontrola funkčnosti
-  Nesprávná montáž
-  Studená voda  Teplá voda
-  Průtok vody  Žádný průtok vody
-  Volitelná výbava / příslušenství



Technické údaje

- Průtokový tlak: min. 0,5 bar/doporučeno 1-5 bar
- Provozní tlak: max. 10 bar
- Zkušební tlak: 16 bar
- Doporučená teplota vstupní teplé vody: max. 65° C
- Přípojka vody: studená = označená modrou barvou
teplá = označená červenou barvou

Montážní rozměry viz strany 2

Instalace viz obrázek 1a na straně 8 nebo z obrázek 1b na straně 12 nebo z obrázek 1c na straně 15

-  Potrubí na pitnou vodu před a po instalaci důkladně vypláchněte (postupujte podle EN 806 a 1717).
Těsnost přípojek zkontrolujte hydraulickým tlakem.

-  Provoz pouze s pitnou vodou.
-  Výrobek je vhodný výhradně k montáži ve vnitřních prostorech!
-  **Pozor!** Instalace v prostorech, které nepromrzají.

Náhradní díly s objednáacími čísly viz strany 19.

Symbole i znaczenie





-  **Uwaga!** Ostrzeżenie przed szkodami osobowymi i materialnymi.
-  **Uwaga!** Ostrzeżenie przed porażeniem prądem elektrycznym.
-  **Uwaga!** Ostrzeżenie przed szkodami, spowodowanymi przez wodę.
-  Informacja, dobra rada lub odsyłacz
-  Właściwy montaż / kontrola funkcjonowania
-  Niewłaściwy montaż
-  Woda zimna  Woda gorąca
-  Strumień wody  Brak strumienia wody
-  Opcje / Osprzęt

Dane techniczne

- Ciśnienie hydrauliczne: min. 0,5 bar/zalecane 1-5 bar
- Ciśnienie robocze: maks. 10 bar
- Ciśnienie kontrolne: 16 bar
- Zalecana temperatura wody gorącej na wejściu: maks. 65° C
- Przyłącze wody: zimna = oznaczenie niebieskie
gorąca = oznaczenie czerwone

Wymiary zabudowy, patrz strona 2

Instalacja, patrz rys. 1a na stronie 8 lub z rysunku 1b na stronie 12 lub z rysunku 1c na stronie 15

-  Przed instalacją i po instalacji należy gruntownie przepłukać przewody, prowadzące wodę pitną (należy stosować się do EN 806 i 1717).
Sprawdzić przyłącza ciśnieniem hydraulicznym w celu potwierdzenia ich szczelności.
-  Możliwa eksploatacja w instalacji wody, zapewniającej jakość typową dla wody pitnej.
-  Produkt przeznaczony jest wyłącznie do montażu wewnątrz budynków!
-  **Uwaga!** Instalacja wyłącznie w pomieszczeniach, w których temperatura nie spada poniżej zera.

Części zamienne z numerami zamówienia, patrz strona 19.

1a

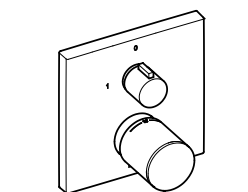
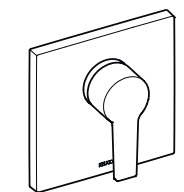
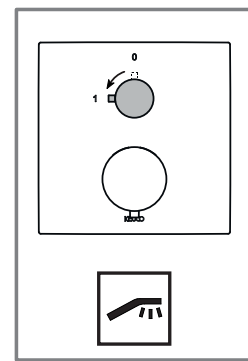
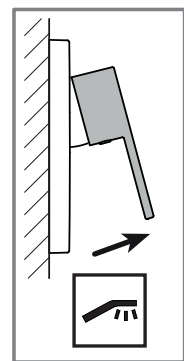
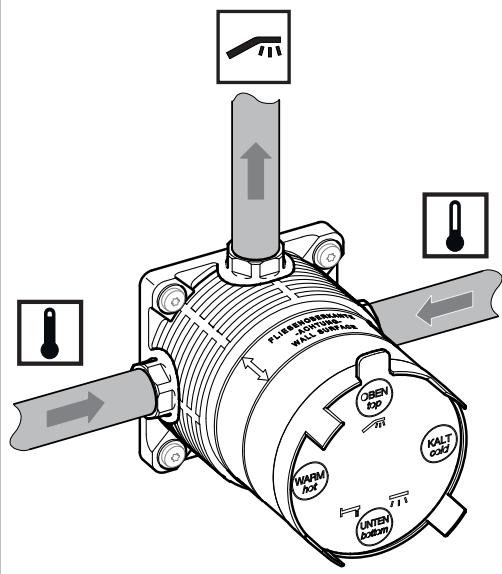

5XX71 01018X

5XX73 01018X

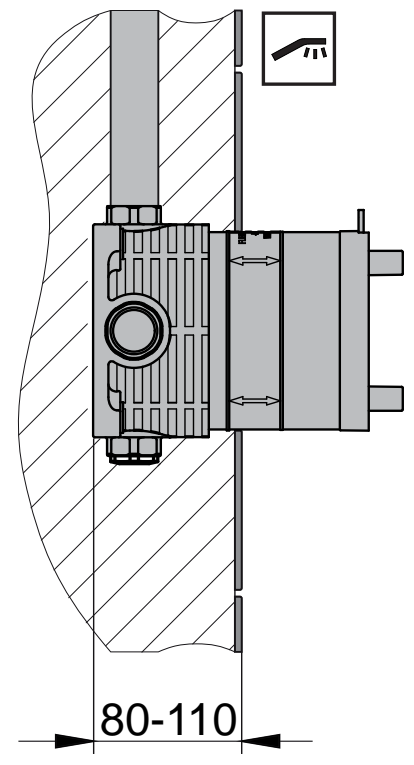

2a

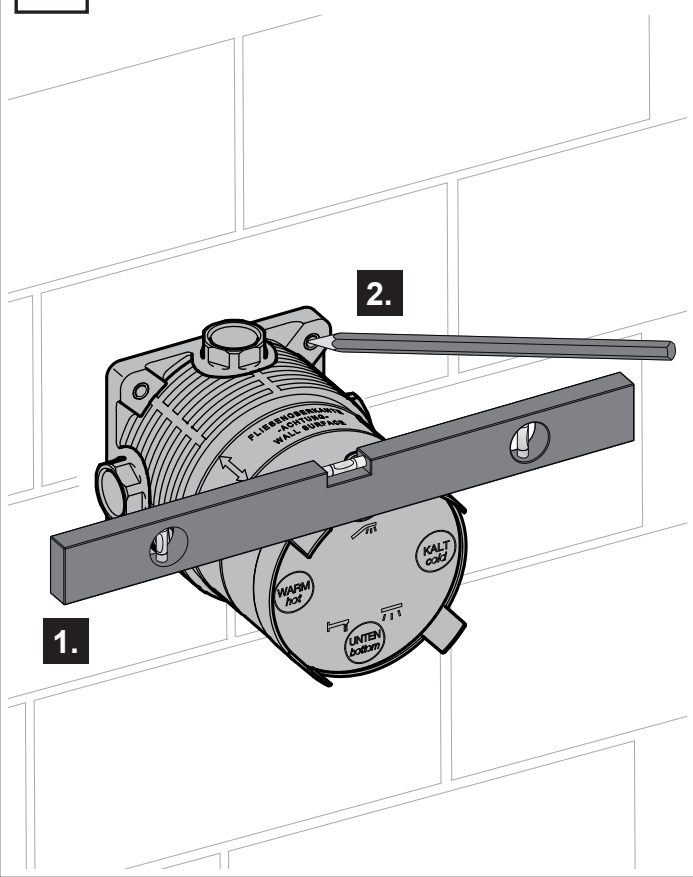

3a

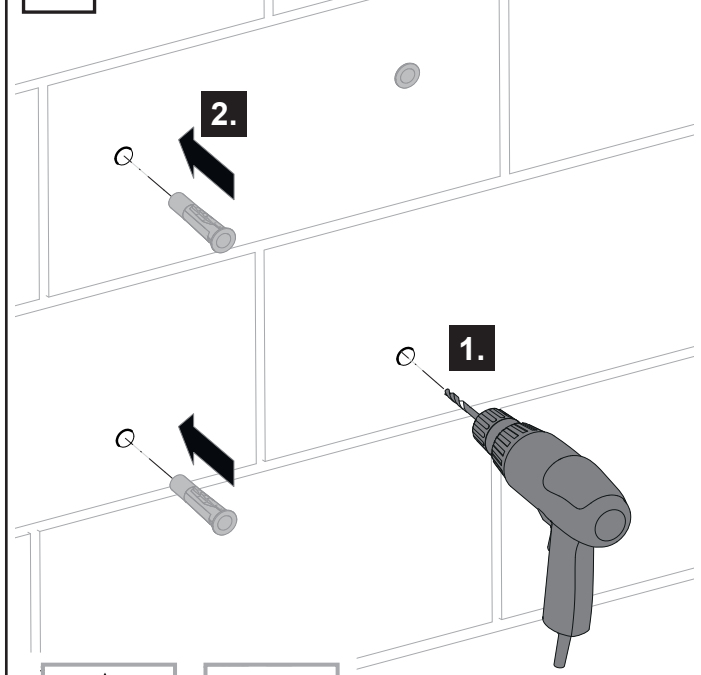

4a

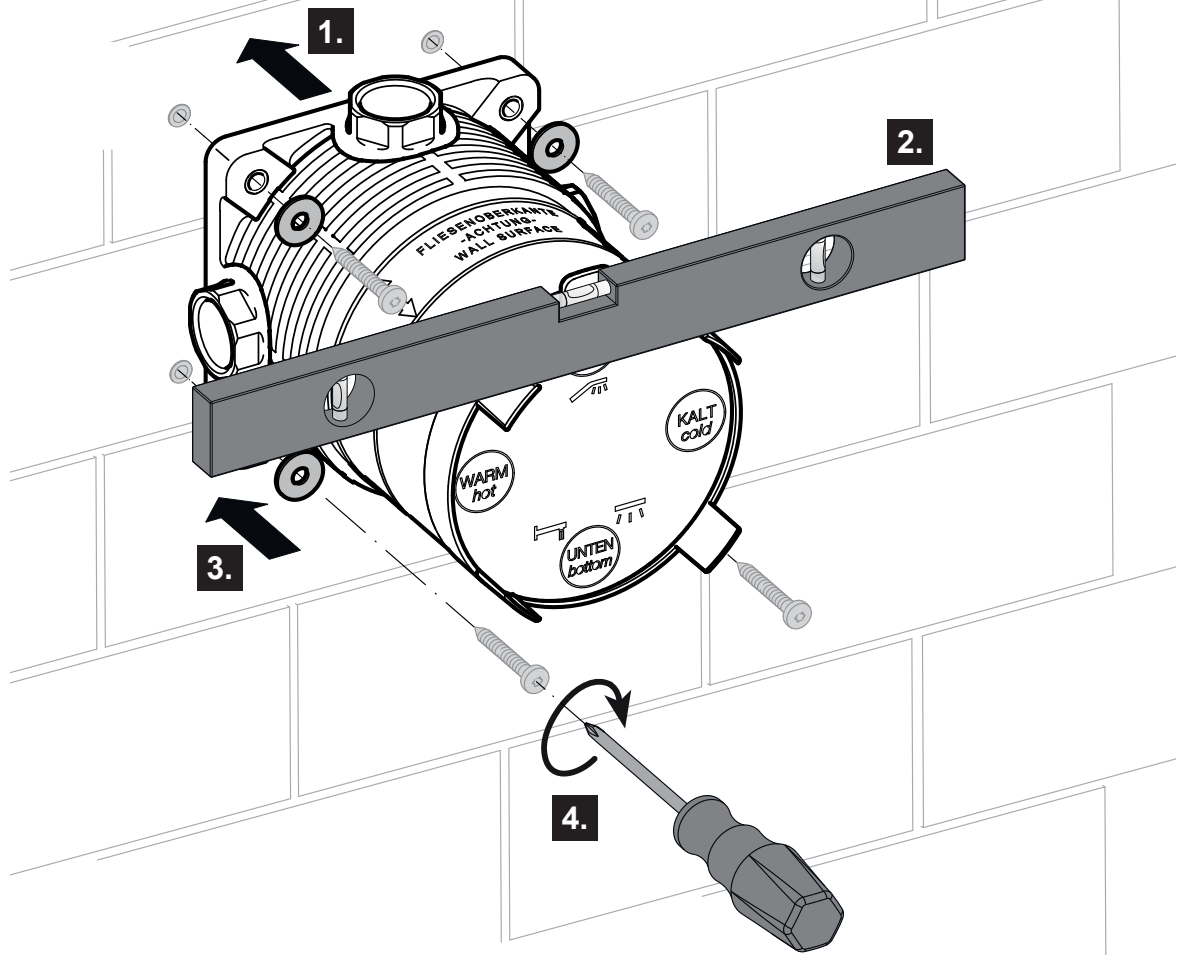

5a

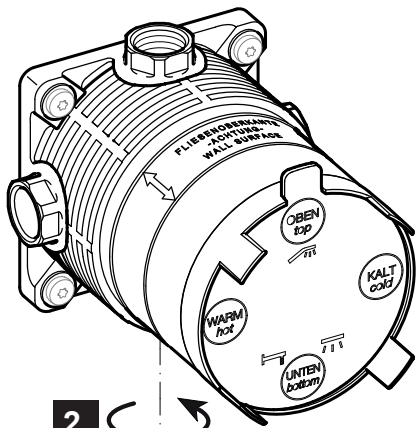
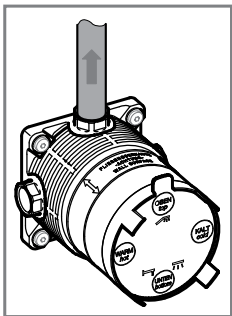

2.

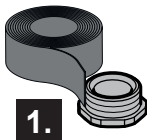
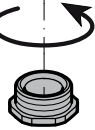

1.

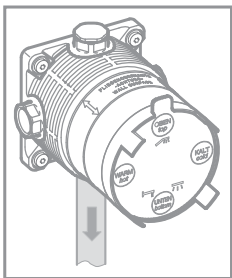

6a

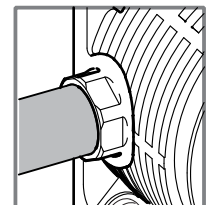
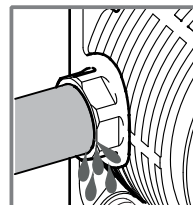
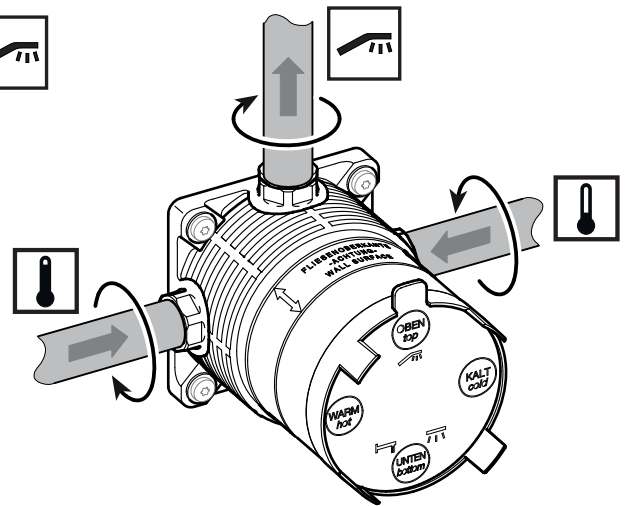

7a

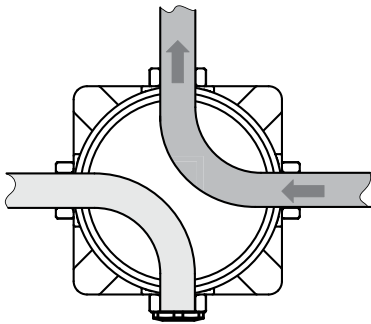
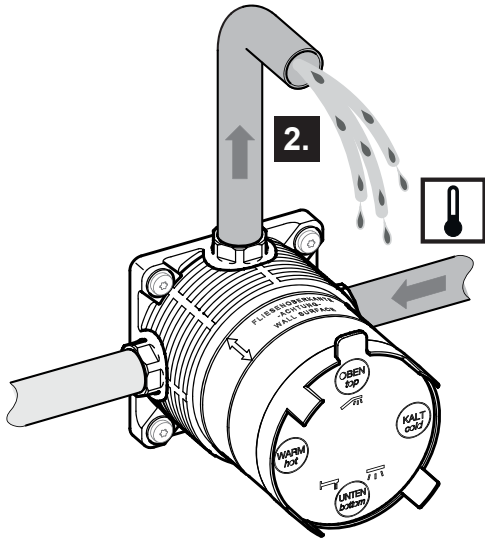
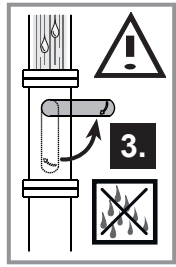
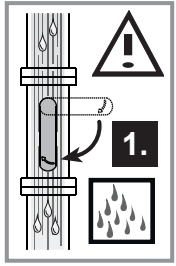

8a

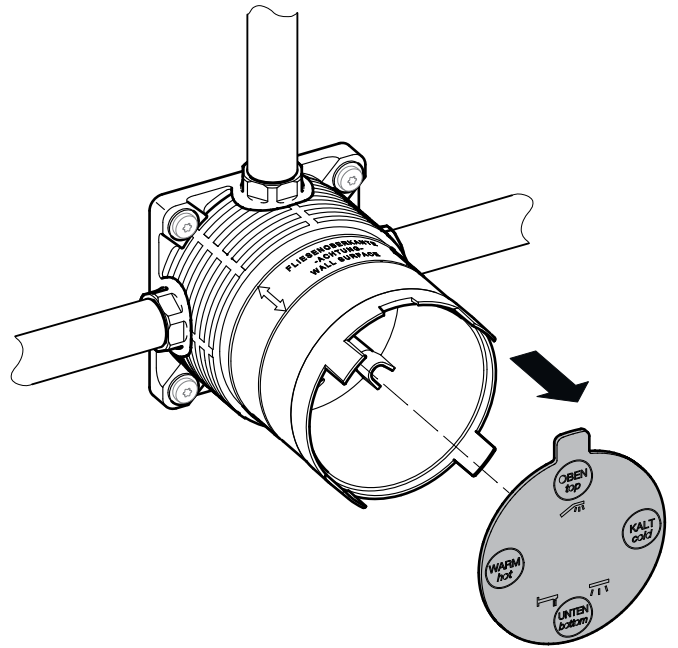

9a

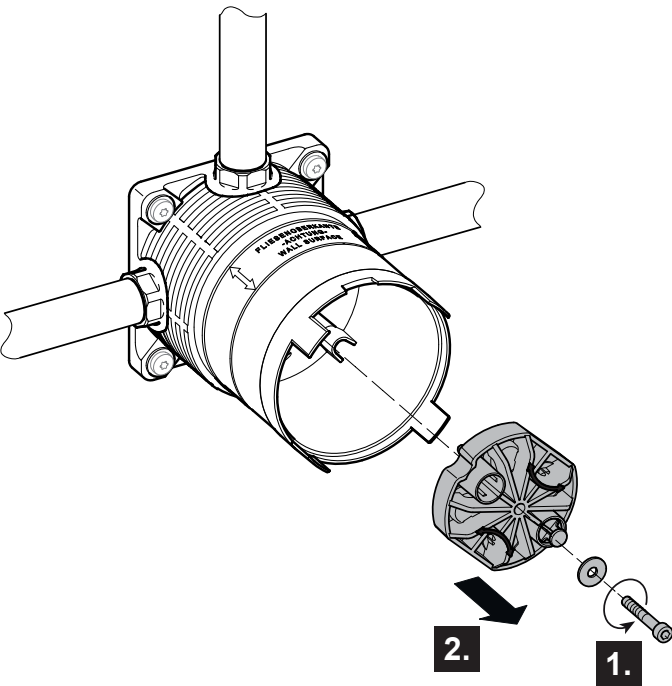

10a

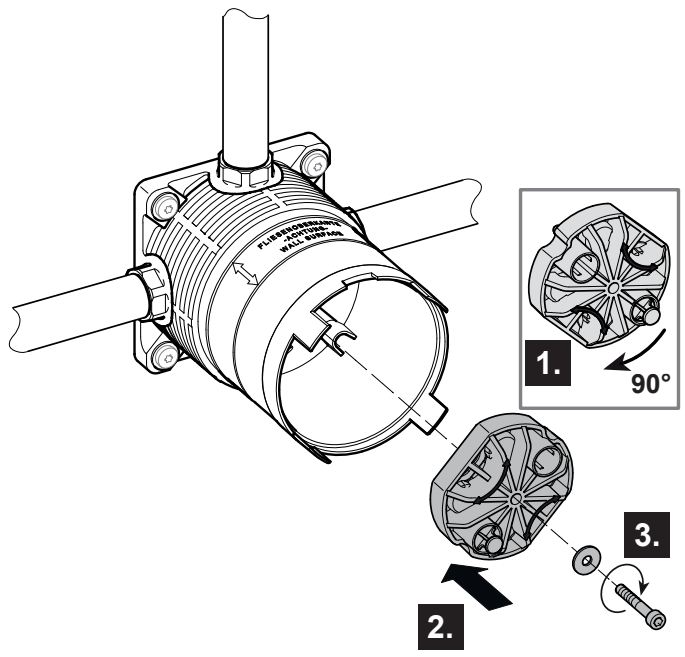

11a

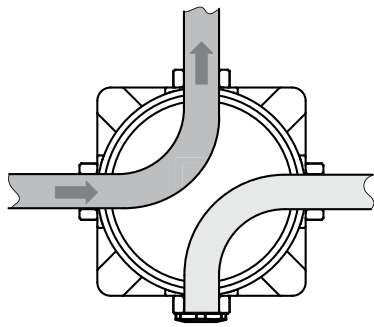
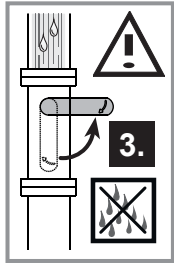
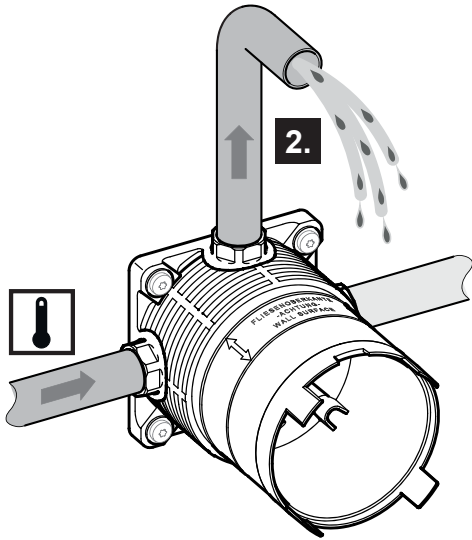
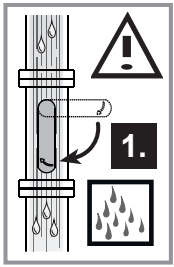

12a

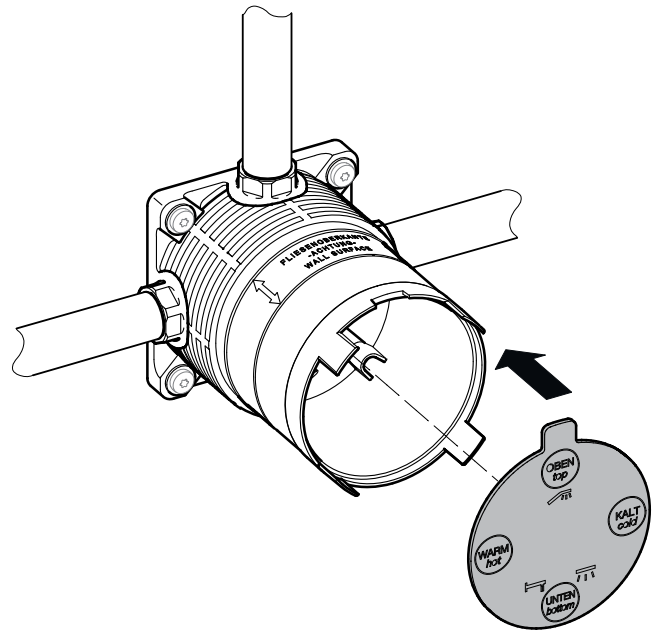

13a

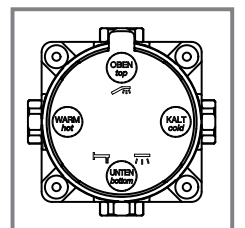
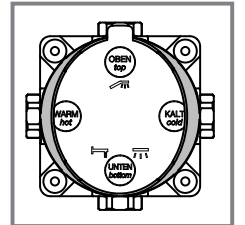
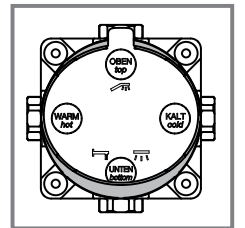
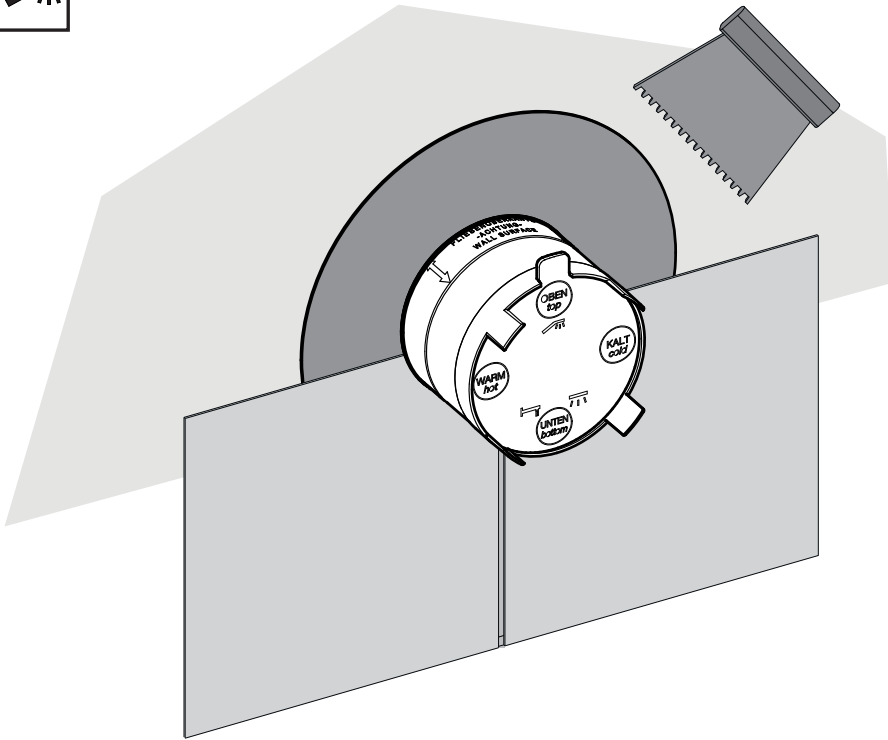

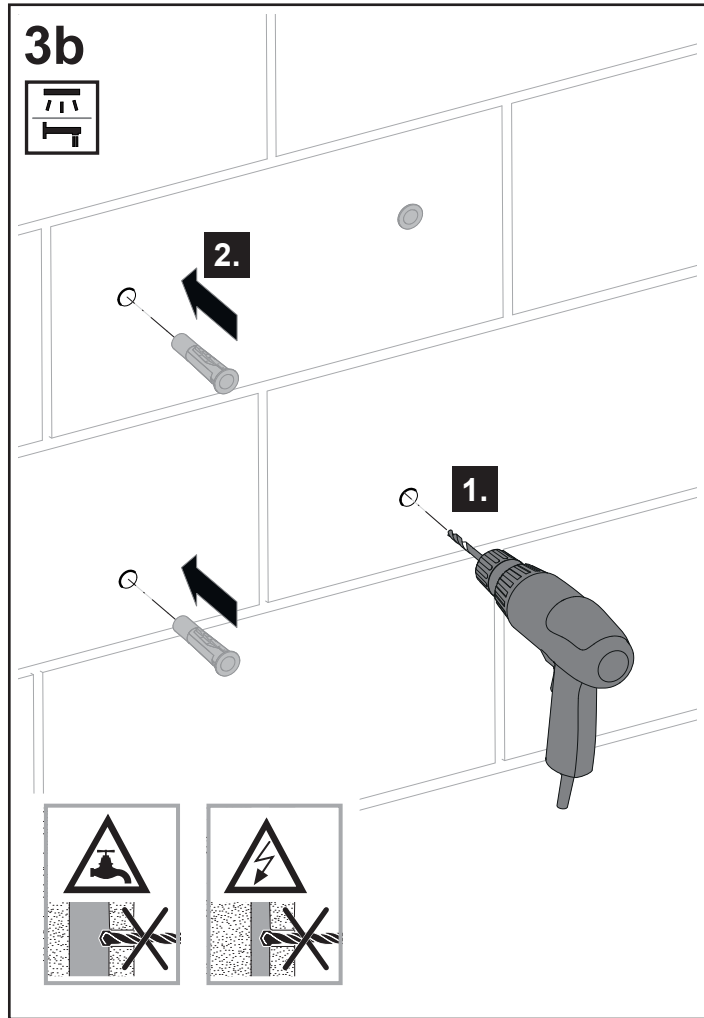
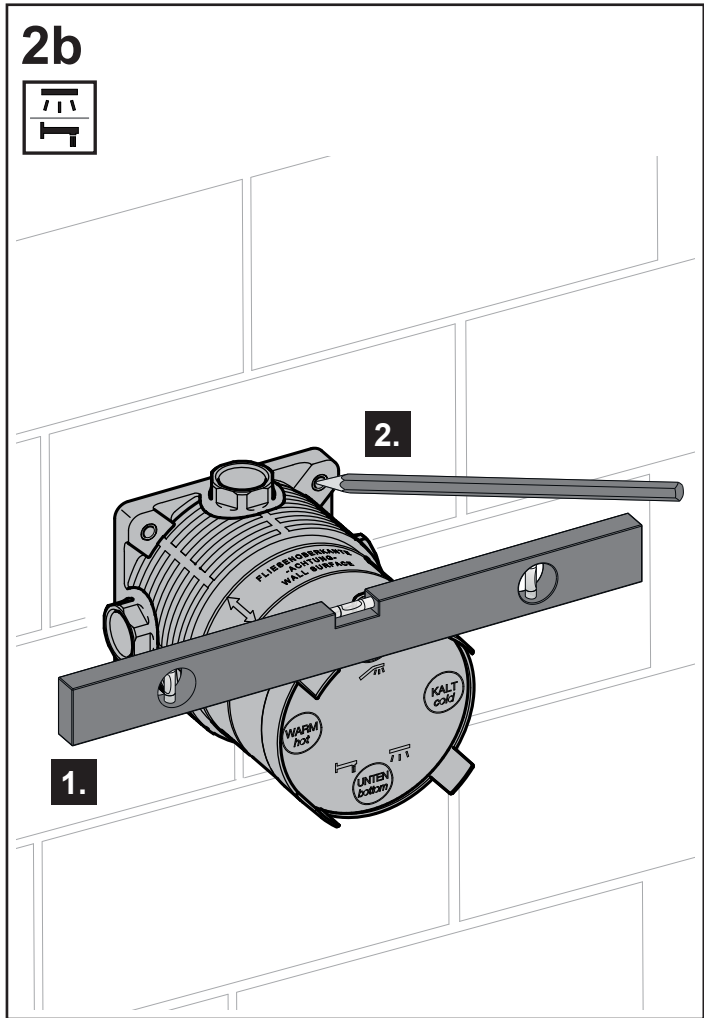
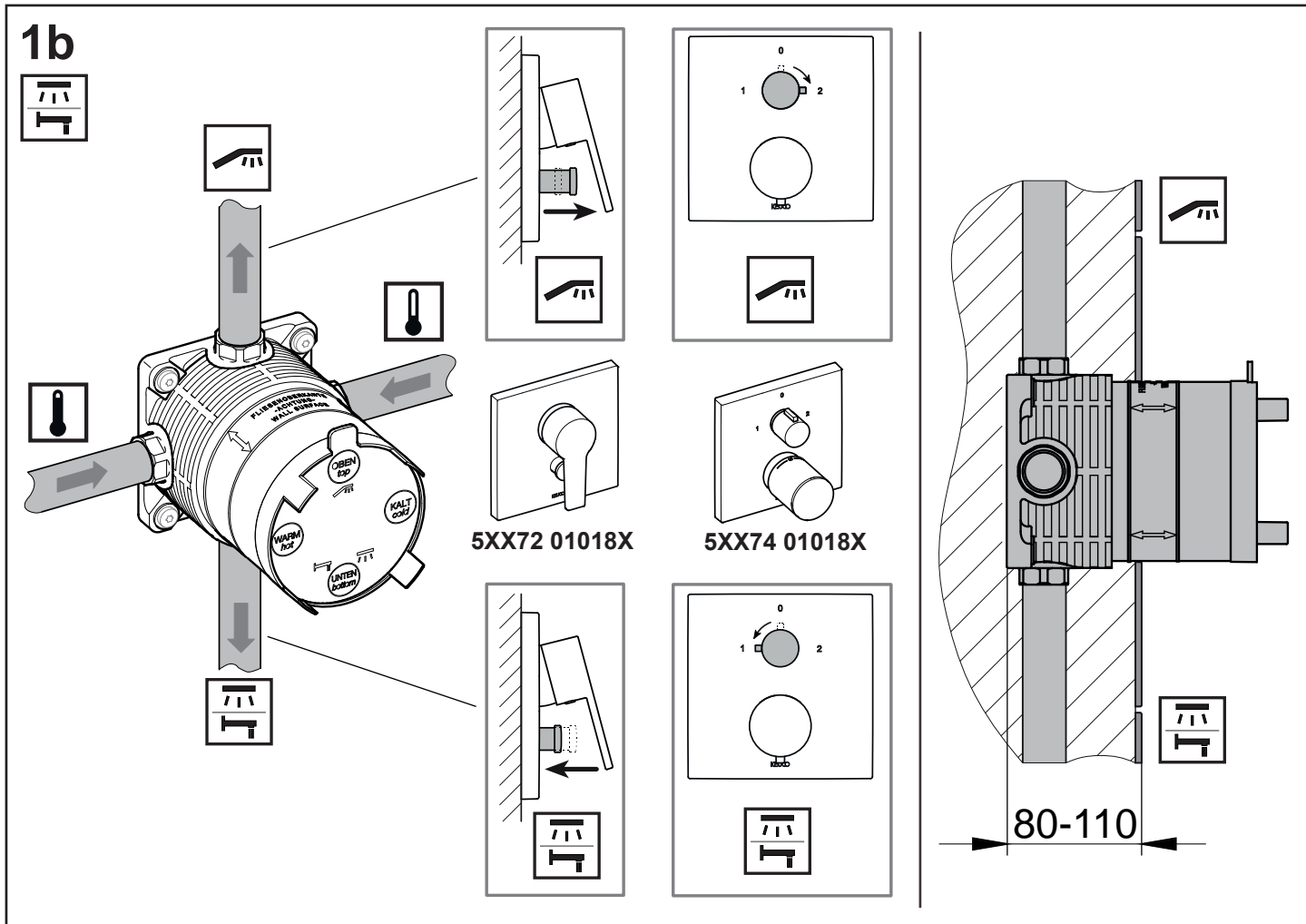

4b

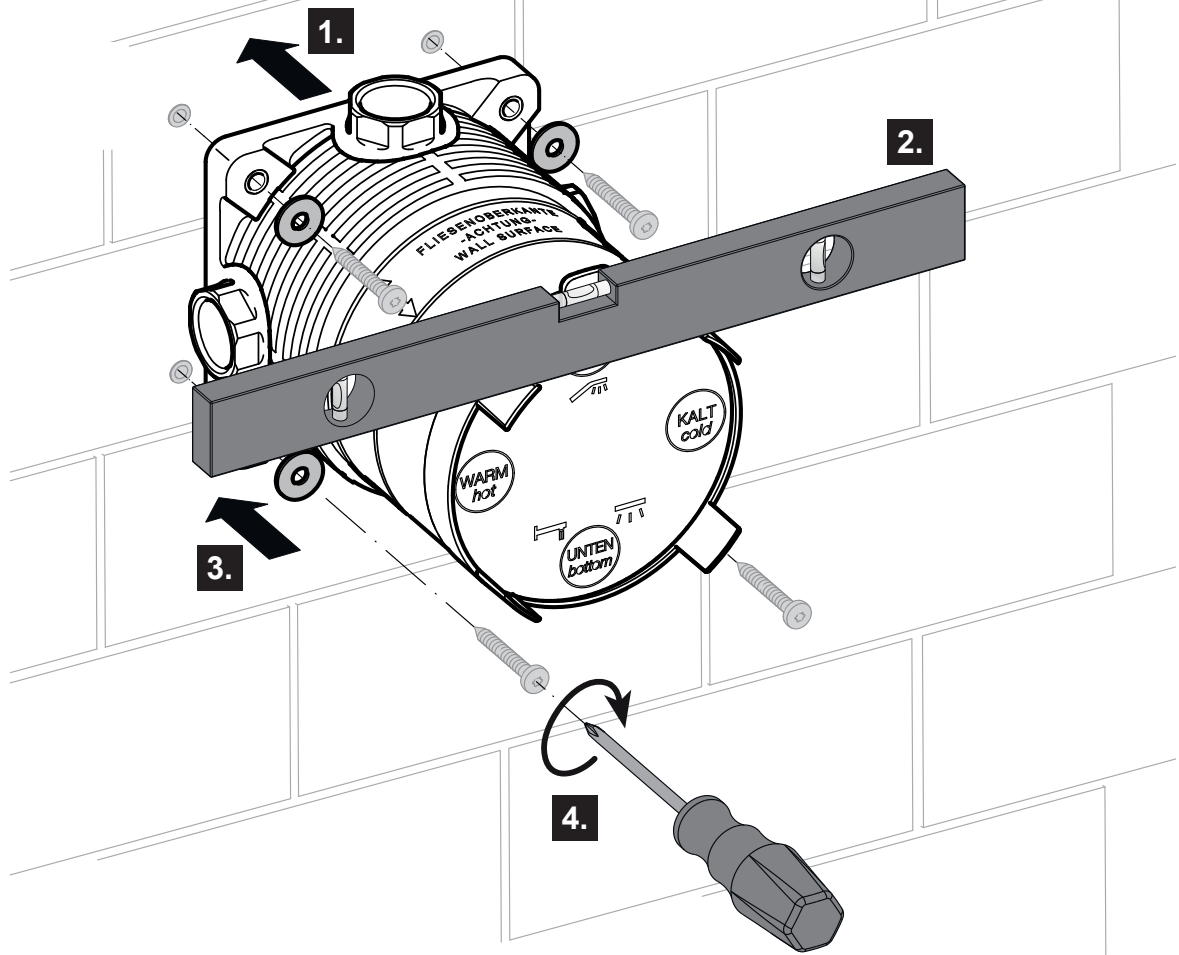

5b

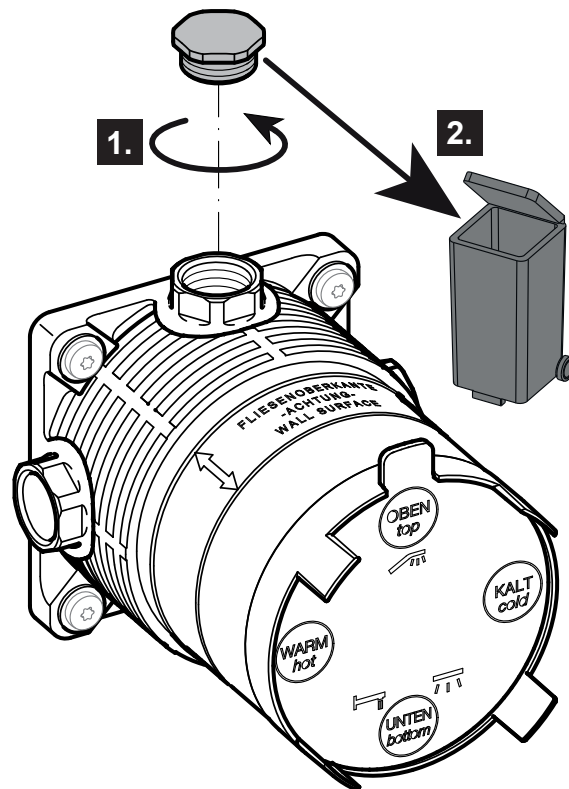
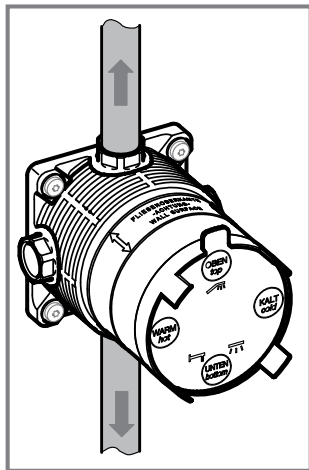

6b

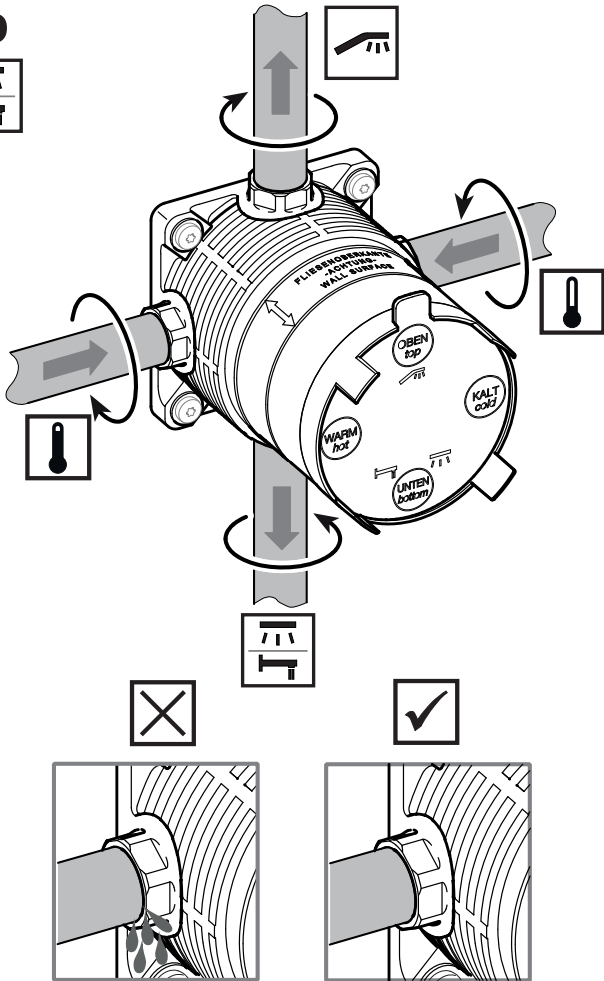

7b

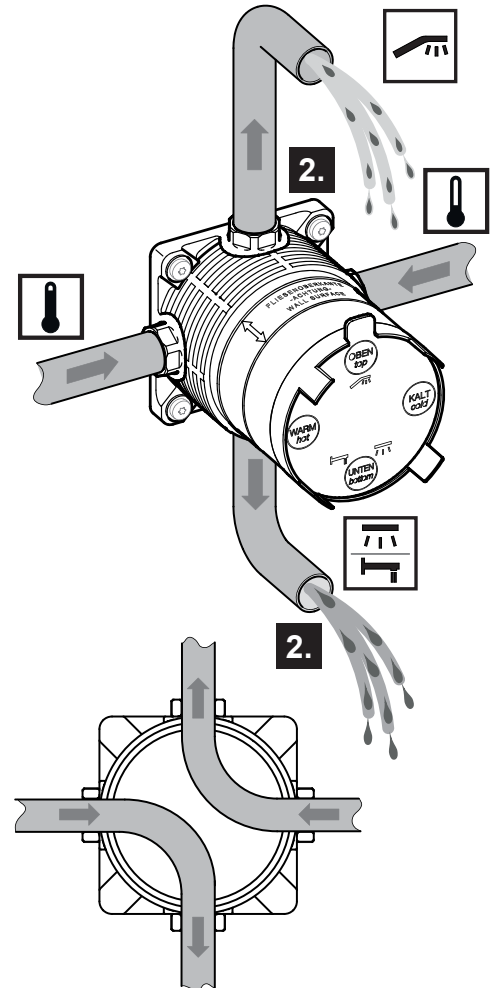
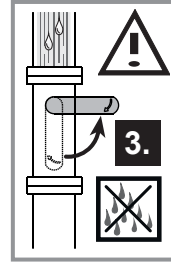
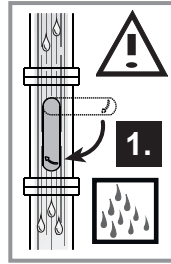

8b

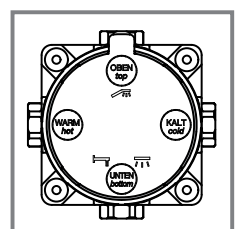
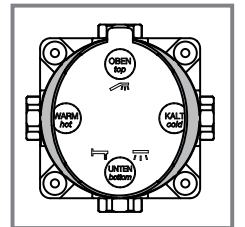
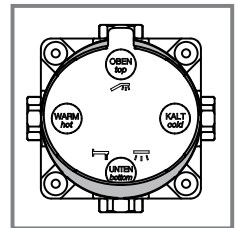
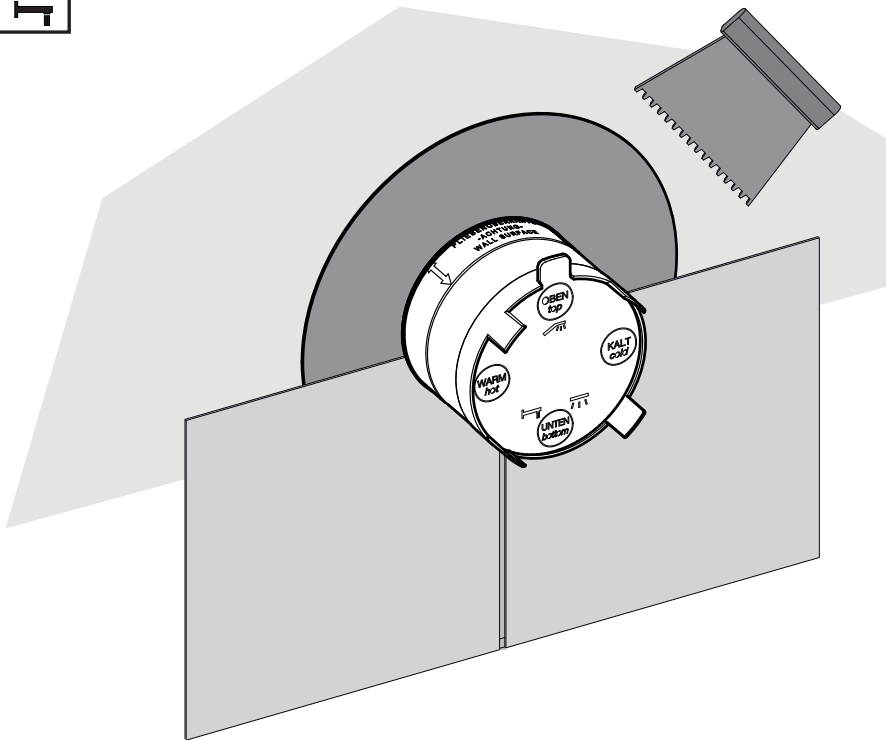

1c

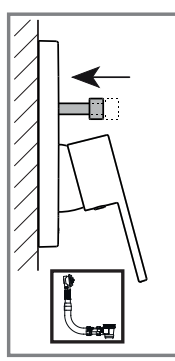
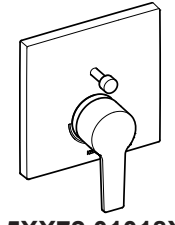
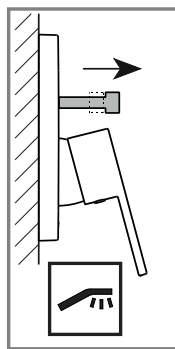
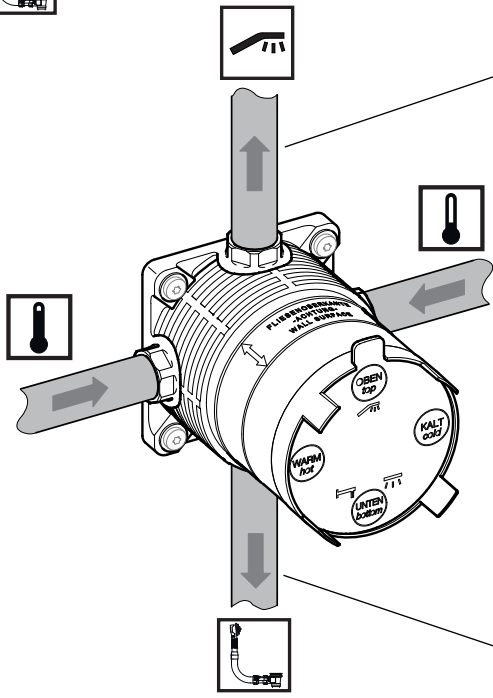

5XX72 01018X

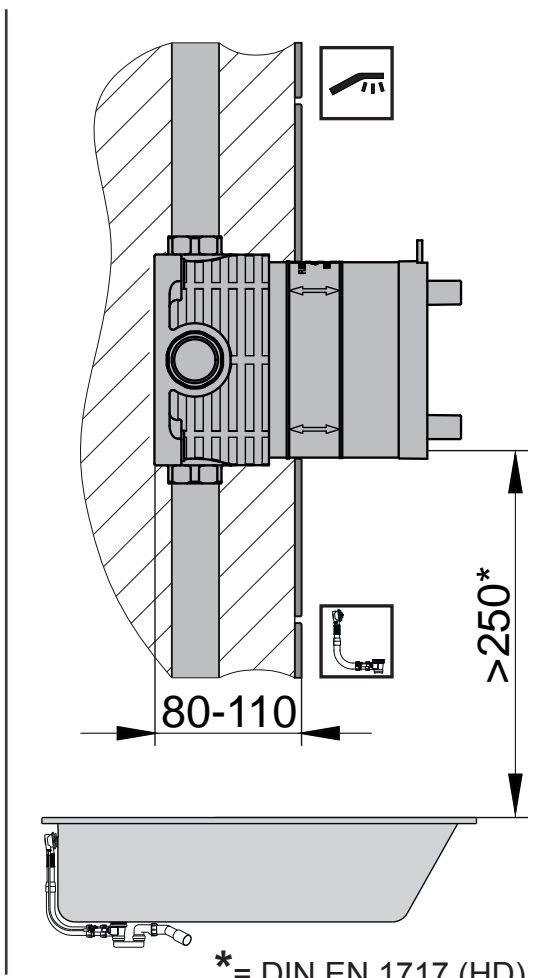

* = DIN EN 1717 (HD)

2c

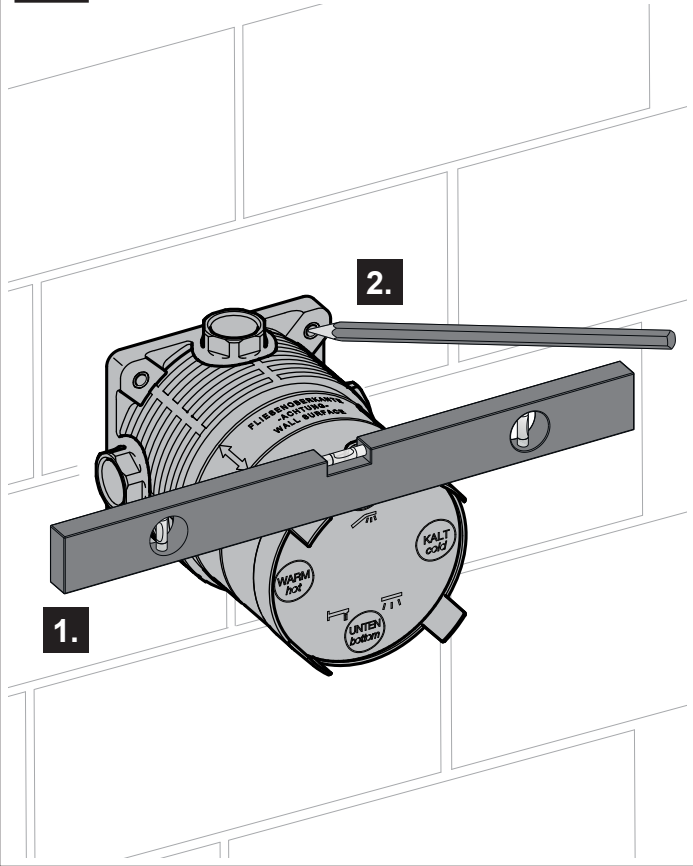

3c

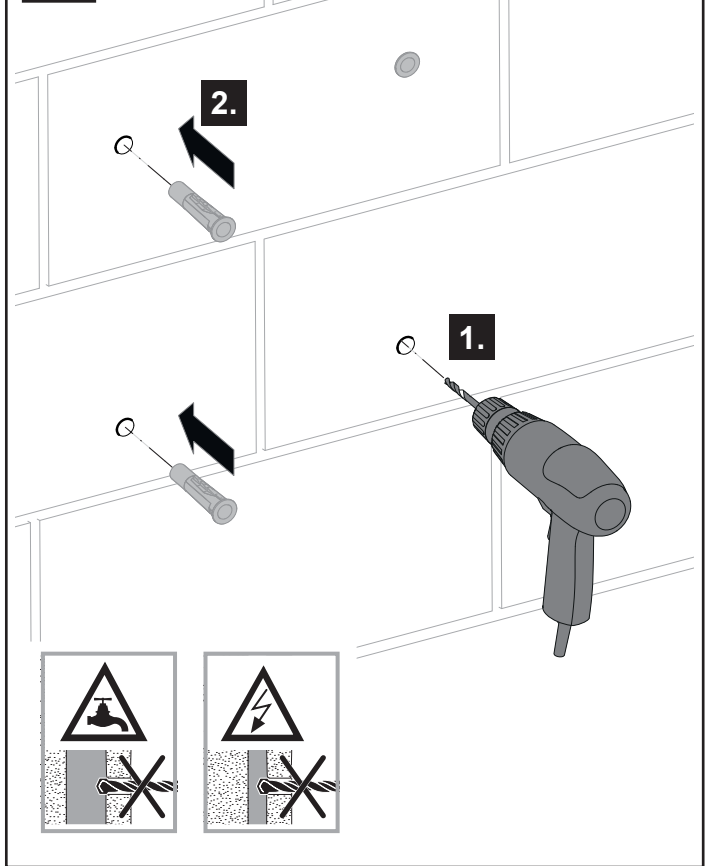

4c

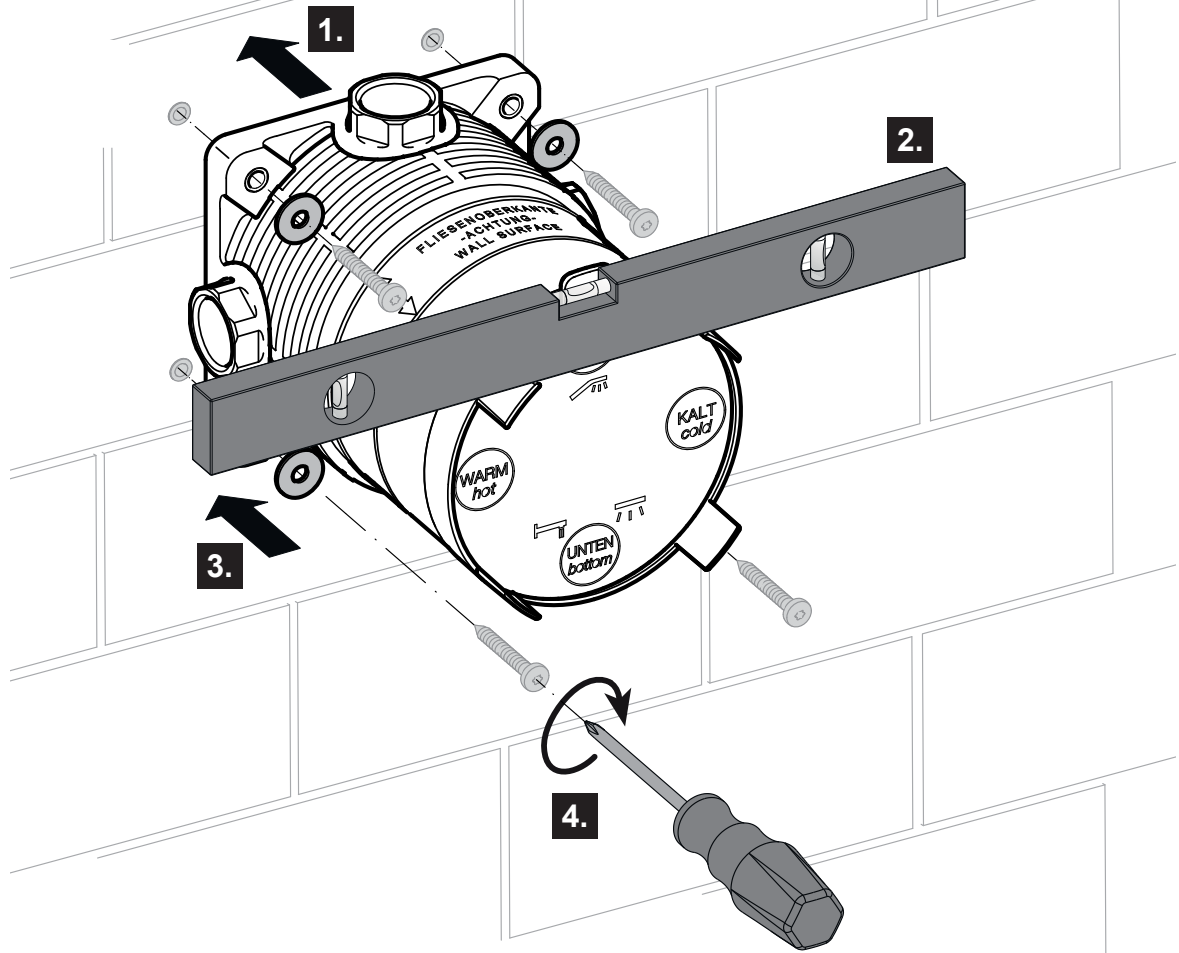

5c

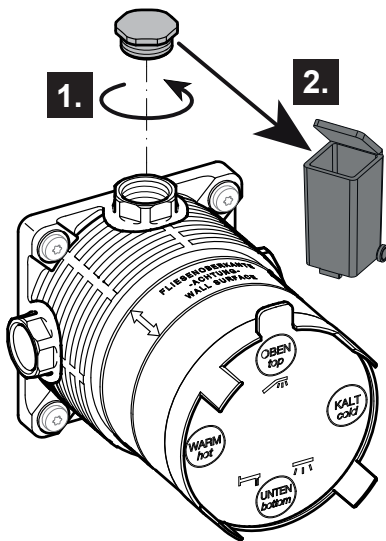
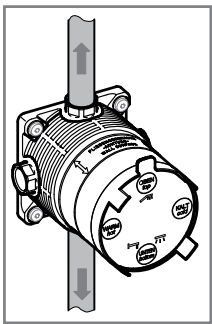

6c

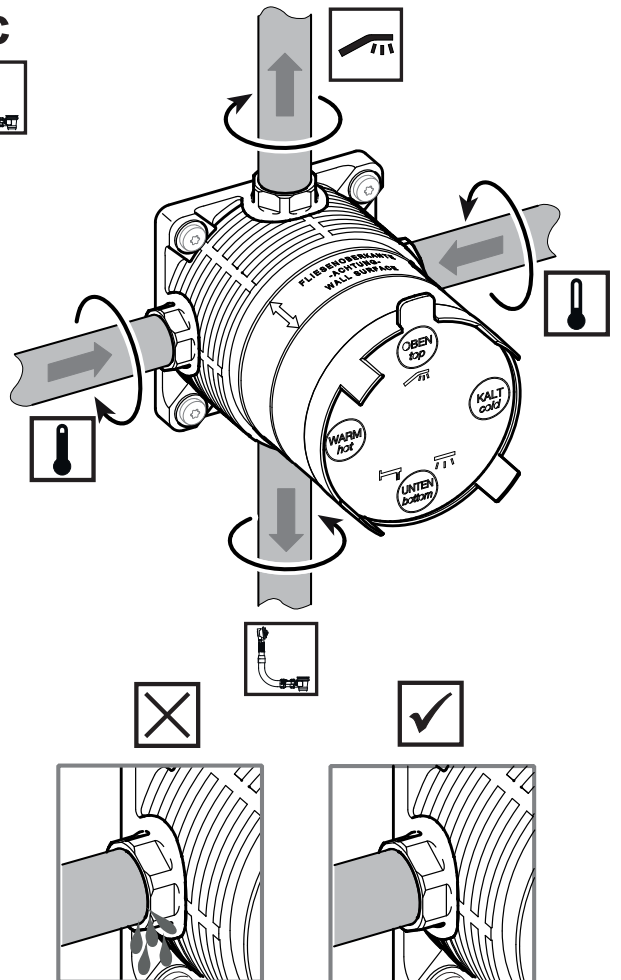

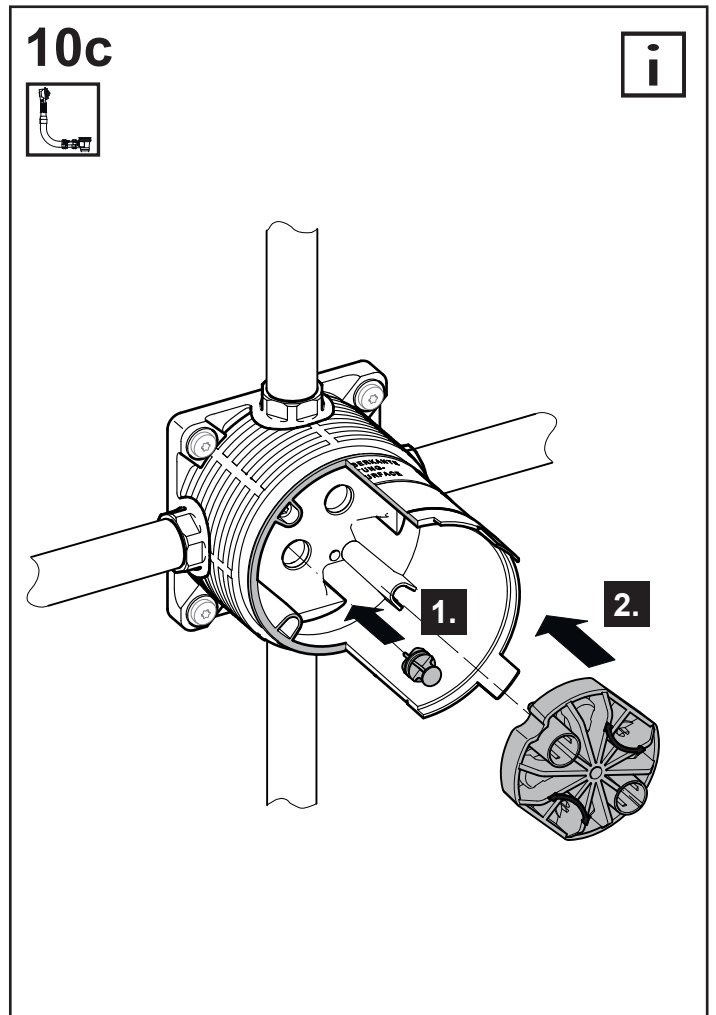
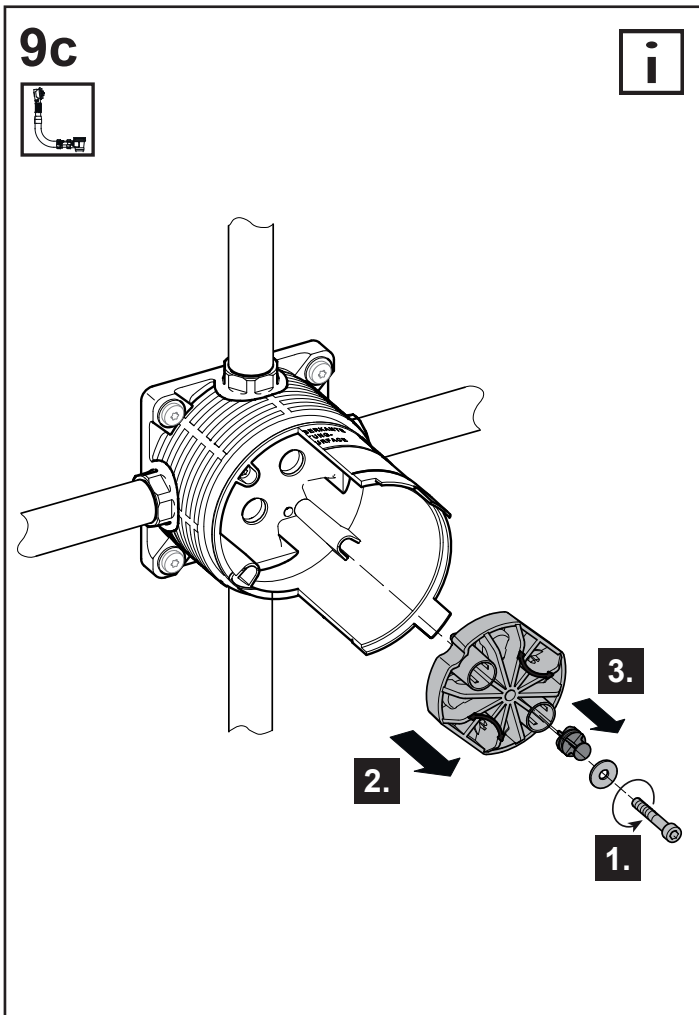
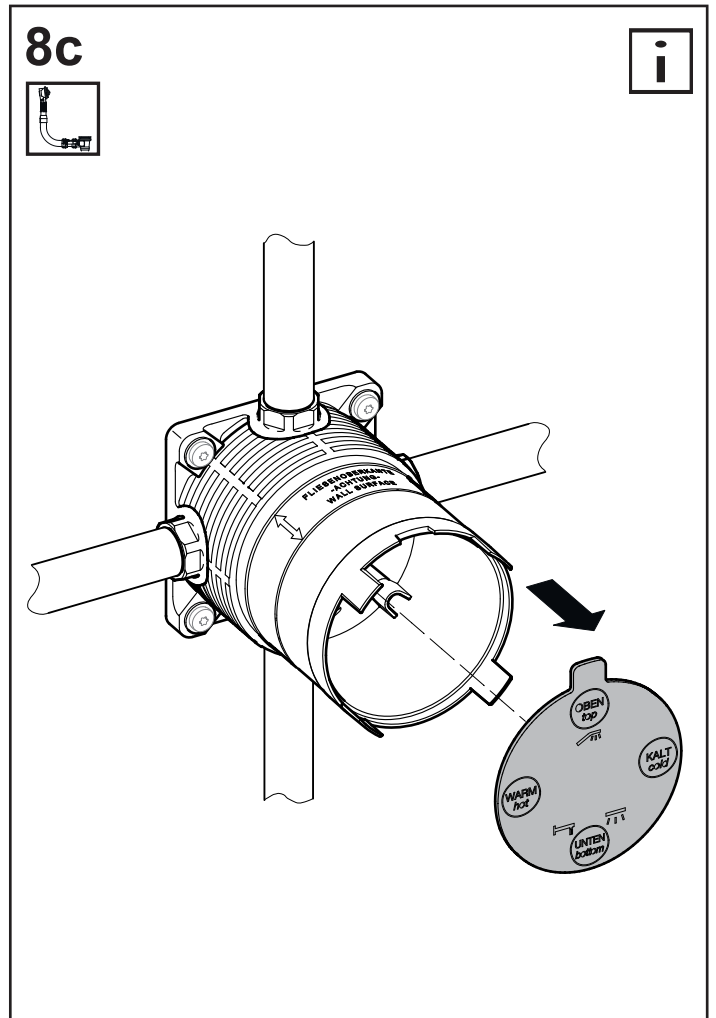
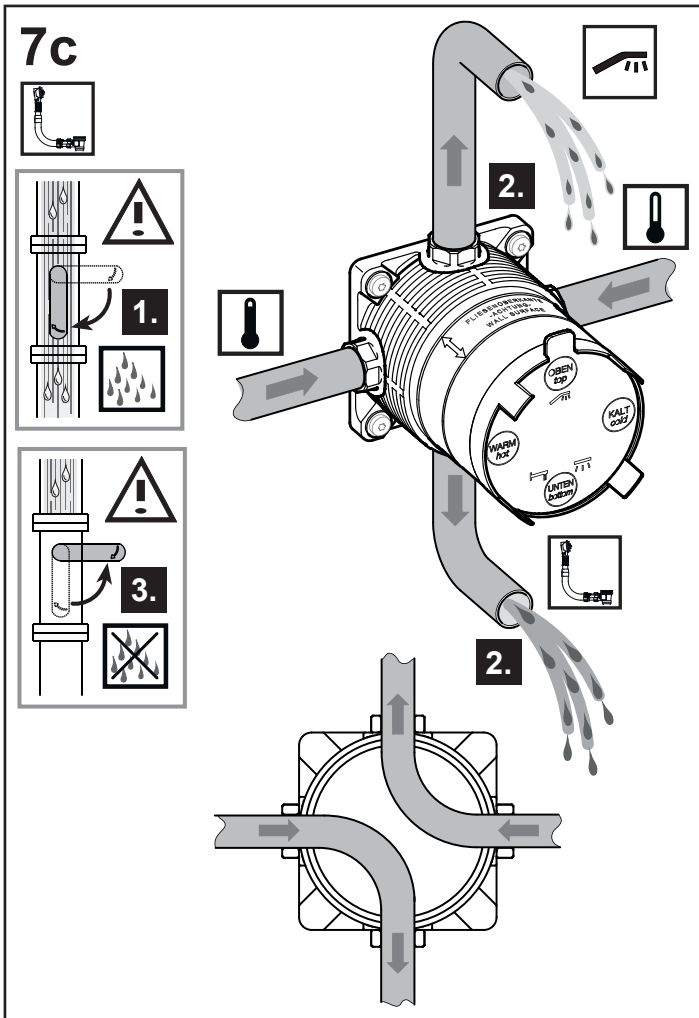

11c

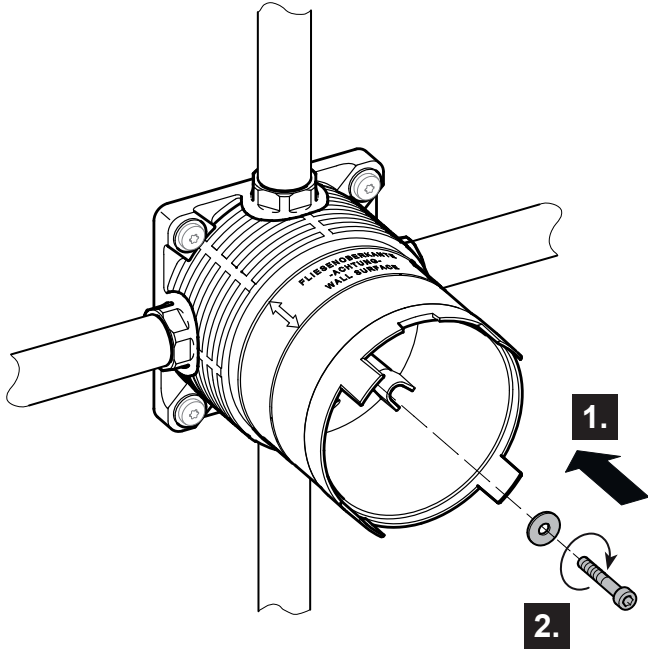

12c

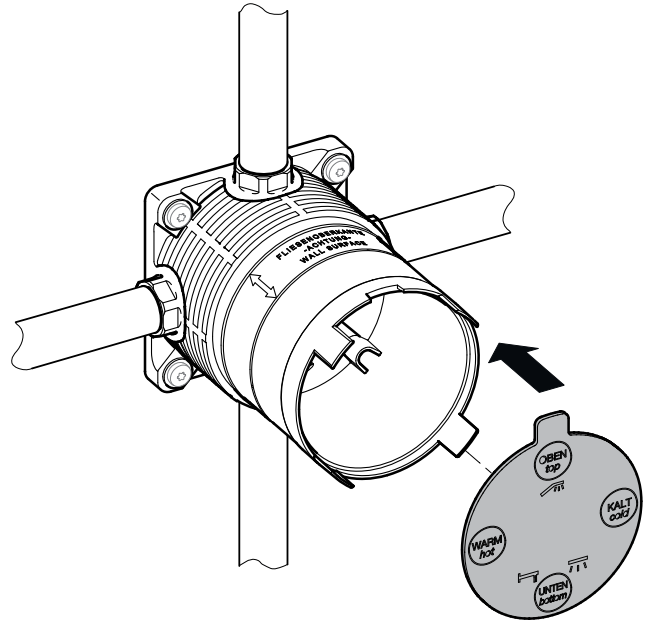

13c

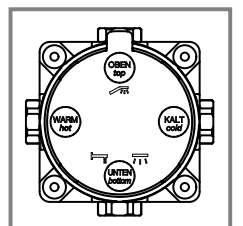
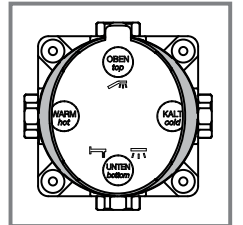
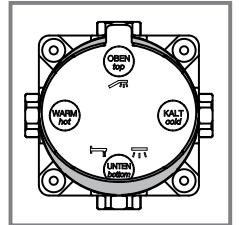
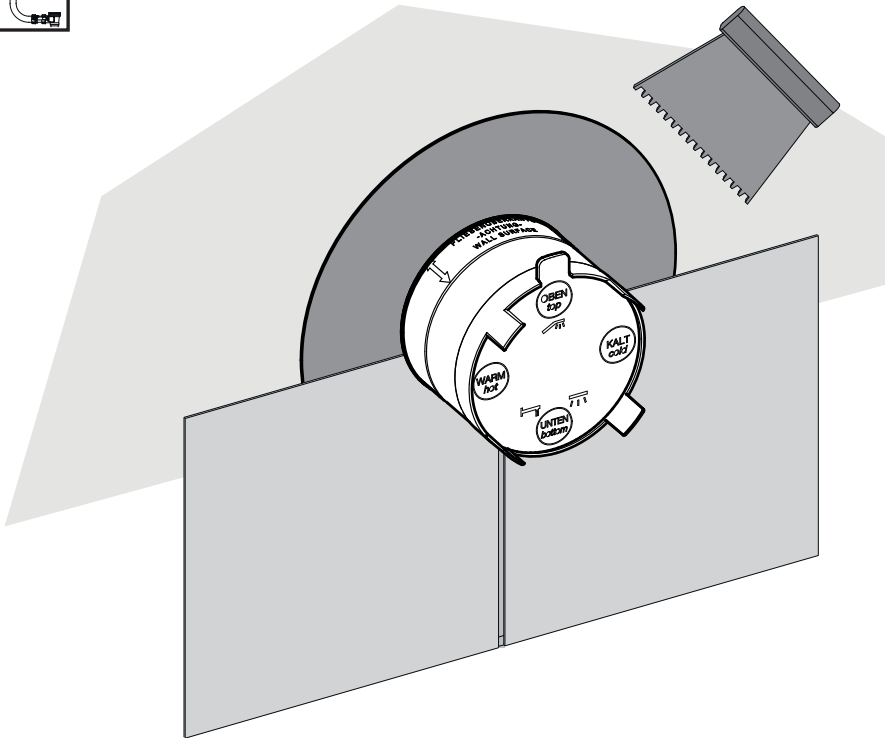

DE Ersatzteile

FR Liste de pièces

CS Sada náhradních

EN Spare parts

IT Elenco delle parti

PL Zestaw części

ES Piezas de recambio

NL Onderdelen

RU Запчасти

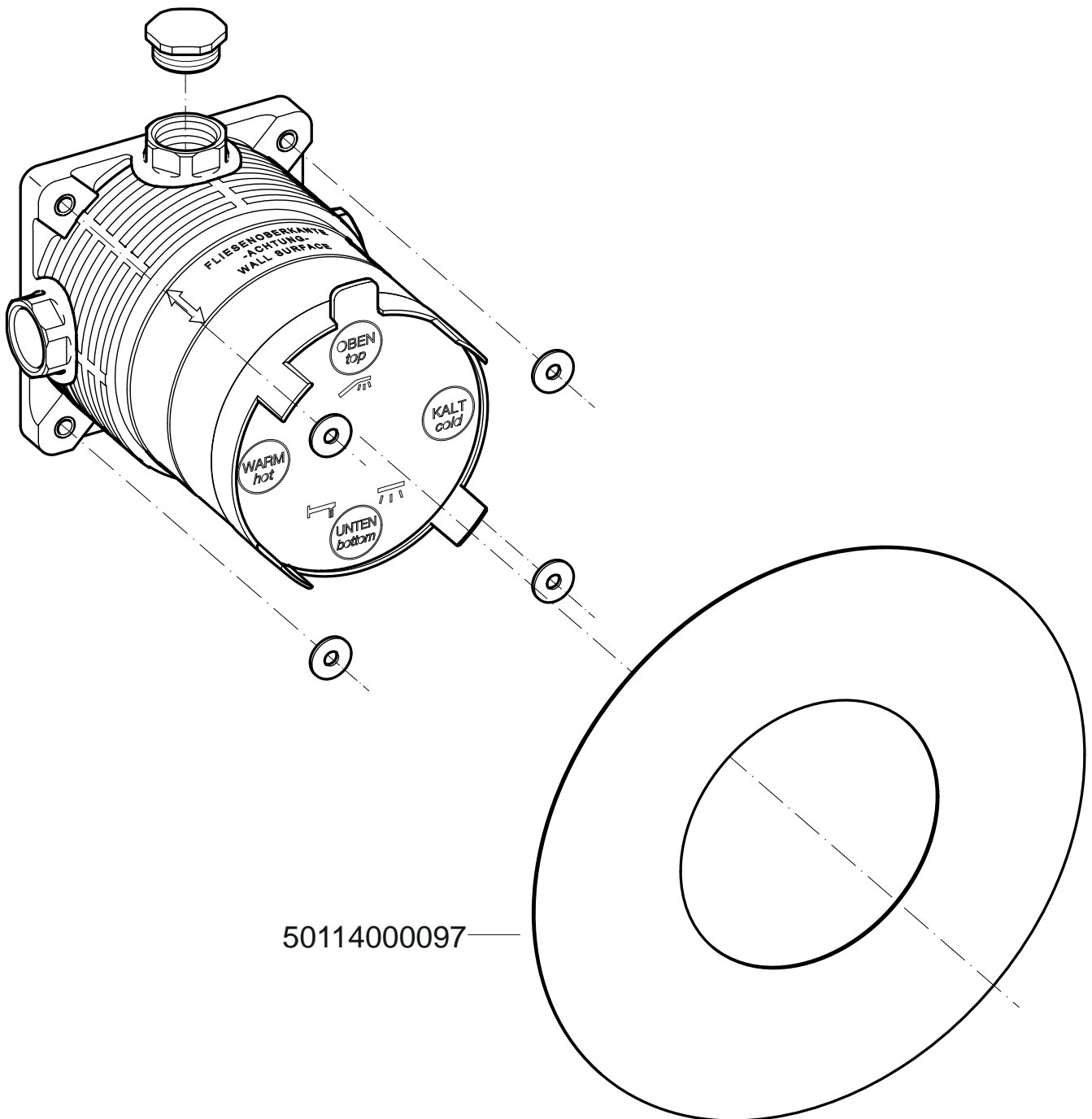

5011400097

59970 000070

