

DREAME

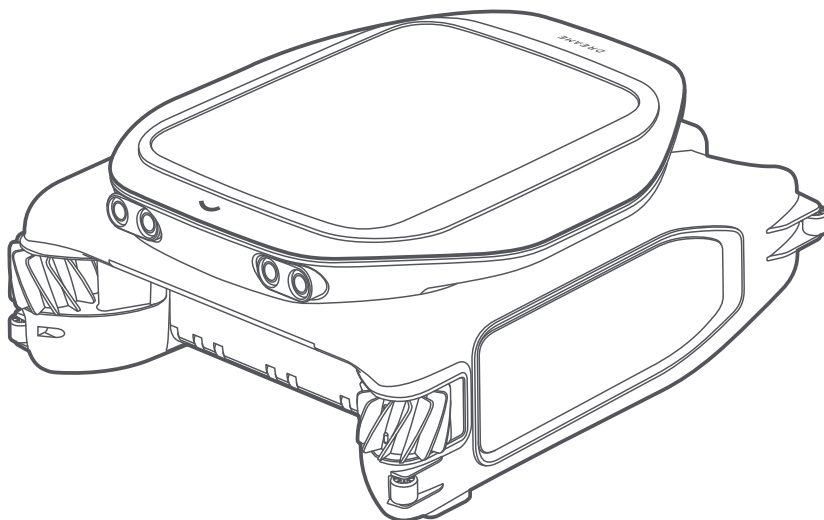

Robotic Pool Skimmer

Dreame J1

User Manual

The illustrations in this manual are for reference only. Please refer to the actual product for accuracy.

DECLARATION OF CONFORMITY

Quilo Technology (Jiaxing) Co., Ltd.

Room 199, No. 2176 Fanggong Road, Dongzha Street, Nanhu District, Jiaxing City, Zhejiang Province, P.R.China

On behalf of Quilo Technology declare that the product

Description: **Robotic Pool Skimmer**

Type: **PNUJ4110**

Function: **Pool cleaning**

Complies with the following Directives

2006/42/EC, 2014/30/EU, 2014/35/EU, 2011/65/EU&(EU)2015/863,2014/53/EU

Standards conform to,

EN 60335-1:2012+A11+A13+A1+A14+A2:2019+A15:2021, +A16:2023,

EN 60335-2-29:2004+A2+A11:2018, EN 62233:2008, EN 55014-1:2017+A11:2020,

EN 55014-2:2015, EN IEC 61000-3-2:2019, EN 6 1000-3-3:2013+A1:2019, EN ISO 3744:2005,

EN300 328V2.2.2, EN 301 489-1V2.2.3, EN 301 489-17 V3.2.4, EN IEC 62311:2020,

EN 61558-1:2005+A1:2009, EN 61558-2-16:2 009+A1:2013, EN 55011:2016+A11:2020,

EN 303 447 V1.1.1, EN 55032:2015+A11:2020, EN 55035:2017+A11:2020

Manufacturers authorized EU Representative

EUREP GmbH

Unterlettenweg 1a, 85051 Ingolstadt,Germany

eurep@eurep-gmbh.com

+49 841 8869 7744

Place of Issue: Suzhou

Date of Issue: 05/01/2024

Issuer's signature: *Lucien. Shen*

Name of Issuer: Lucien.Shen

Position of the issuer: Quality Director

Room 199, No. 2176 Fanggong Road, Dongzha Street, Nanhu District, Jiaxing City, Zhejiang Province, P.R.China



1. Safety Instructions

1.1 Safety Regulations

- READ AND FOLLOW ALL INSTRUCTIONS.
- SAVE THESE INSTRUCTIONS.
- Do not swim when the robot is working in the pool. Take the robot out of the pool when not in use and put it in a sunny area for charging.
- Children shall not play with this device. It is not a toy. Ensure children and pets are kept at a safe distance from the robot while it is operating.
- Do not use when there are other pool cleaning devices in the pool.
- For storage, place the robot in a cool, dry place and avoid direct sunlight. Do not leave the robot unattended in hot areas outside the pool to prevent serious damage.
- Do not wash the robot using a pressure washer, as it may damage the equipment.
- Avoid using the robot in strong winds, heavy rain, or thunderstorms, as these weather conditions may affect its performance or cause damage.
- Imbalanced pool chemical composition may corrode or degrade the components of the robot. Do not use the robot when the pool is undergoing shock chlorination. Moreover, avoid using strong chemical cleaners that may damage its outer layer when cleaning the robot.
- Parts will naturally wear out over time with regular use. Components such as side brushes and filters may need to be replaced periodically. Follow the instructions for regular cleaning and maintenance to extend the lifespan of the robot. Use recommended parts and replacements to ensure the optimal performance.
- Keep away from sharp objects that may damage the surface of the robot. Please note that you should move and operate the robot gently to prevent damage from falls or impacts when handling or operating the robot.
- This appliance can be used by children aged from 8 years and above and persons with reduced physical, sensory or mental capabilities or lack of experience and knowledge if they have been given supervision or instruction concerning use of the appliance in a safe way and understand the hazards involved. Children shall not play with the appliance. Cleaning and user maintenance shall not be made by children without supervision.
- The device contains batteries that can only be replaced by qualified technicians. Do not modify or attempt to repair the robot or the battery except as indicated in the instructions for use and care. Have servicing performed by a qualified repair person using only identical replacement parts.

- Under abusive conditions, liquid may be ejected from the battery; avoid contact. If contact accidentally occurs, flush with water. If liquid contacts eyes, additionally seek medical help. Liquid ejected from the battery may cause irritation or burns. (This advice is considered correct for conventional NiMh, NiCd, lead acid and lithium-ion cell types. If this advice is incorrect for a cell design that differs from these, then the correct advice may be substituted.)
- Do not use a battery pack or appliance that is damaged or modified. Damaged or modified batteries may exhibit unpredictable behavior resulting in fire, explosion or risk of injury.
- Recharge only with the charger specified by the manufacturer. A charger that is suitable for one type of battery pack may create a risk of fire when used with another battery pack.
- Do not expose the appliance or battery to excessive temperatures.
- The power cord is not user-replaceable. If the power cord is damaged, stop using the battery charger and contact the service center for repair. Do not use extension cord to connect the battery charger to electric supply; provide a properly located outlet.
- Switch off the pump from the supply mains before carrying out user maintenance such as cleaning the filter.
- Do not expose a battery pack or appliance to fire or excessive temperature. Exposure to fire or temperature above 130 ° C may cause explosion. The temperature of 130° C can be replaced by the temperature of 265 ° F.
- The robot is not protected against freezing and should not be left outside during freezing water conditions.
- The Lithium-Ion battery in this product is non-replaceable. It should be recycled at certified battery electronics recyclers that accept batteries. Batteries should NOT be discarded in the trash or put in municipal recycling bins. Do not disassemble the battery.
- Do not wash the solar panel using a pressure washer as this may damage the panel.
- The battery must be removed from the appliance before it is scrapped.
- The appliance must be disconnected from the supply mains when removing the battery.
- The battery is to be disposed of safely.

1.2 Correct Disposal of this Product

This marking indicates that this product should not be disposed of with other household waste throughout the EU. To prevent possible harm to the environment or human health from uncontrolled waste disposal, recycle it responsibly to promote the sustainable reuse of material resources. To recycle your used device, please use the return and collection systems or contact the retailer where the product was purchased. They can safely recycle this product.







The remote surveillance is for the absolute private use of non-public, private owned places for the pure selfprotection and single control intended only. Please be aware of the local data protection based legal obligations in case of use. No surveillance of public places, especially with clandestine intent and/or on the part of the employer without justified reasons. Such not justified use is in the risk and responsibility of the user only.



1.3 Water Condition

Chlorine	Max 4 PPM
PH	7.0-7.8
Temperature	5-35° C (41-95° F)
Salt	Max 5000 PPM
Water Depth	≥ 0.15m/5.9 inches

1.4 Symbols and Decals

	Before charging, read the instructions.
	Class II
	Direct current
	Alternating current
IPX8	IP classification
	Water Temp Max: 35 ° C/95 ° F
	WARNING - It is not permitted to dispose of this product as normal household waste. Ensure that the product is recycled in accordance with local legal requirements.

2. Product Overview

2.1 What's in the Box

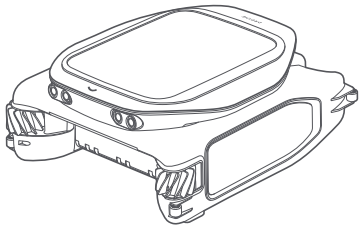

Robot

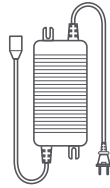

Charger

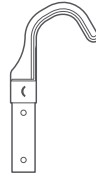

Retrieval Hook



User Manual and Quick Start Guide

Note: The illustrations provided in this document are for demonstration purposes only.

2.2 Structure

Solar Panel

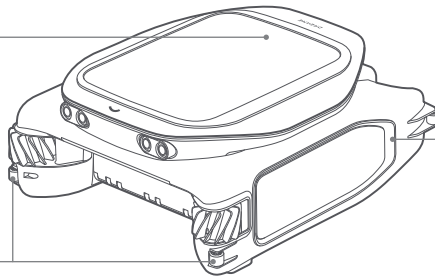

Bumper Strip

Guide wheel

LED Indicator

Release Button

Charging Port (with Cover)

Guide Wheel

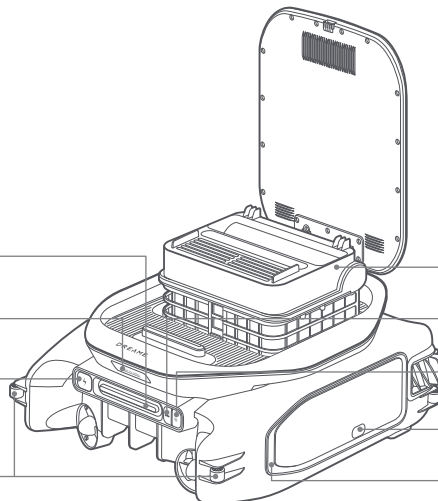

Filter Basket

Mode button

Power Button

Laser Sensor

Bumper Strip

Ultrasonic Sensor

Debris Intake Impeller

Chlorine Dispenser Slot

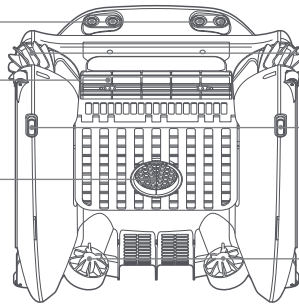

Side Brush



Anti-stranding Bar

Propeller

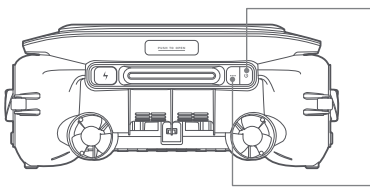
2.3 Controls







Power button:

- To turn the robot on or off, press and hold  for **3** seconds.
- To force the robot to power off, press and hold  for **10** seconds.



Mode button:

- Press  briefly to cycle through cleaning modes: Combo, Waterline, and Surface. The LED indicator will light up under the selected mode.
- To enter Bluetooth pairing mode, press and hold  for **5** seconds. The flashing blue light indicates that the robot is ready to connect.
- To factory reset the robot, press and hold , then quickly press  twice. Ensure both actions are completed within 5 seconds.
- To enable Low-Power Mode, quickly press the Mode button ten times within one minute of powering on the robot.

Indicator

Robot Status	Light Effect	Description
Operation	Blue (Expanding from center to sides)	Powered on.
	Blue (Fading from sides to center)	Powered off.
	Flashing Blue (Slow)	In standby.
	Orange	Low battery level.
Charging	Flashing Orange/Green	Charging in progress. As charging continues, more of the light strip turns solid green.
	Solid Green	Fully charged.
Error	Solid Red	An error has occurred.
Setup	Flashing Blue (Rapid)	In Bluetooth pairing mode.
	Solid Blue	Shows the selected cleaning mode.

3. Before You Begin

3.1 Charging

The robot comes with a partial charge, but it's recommended to fully charge it before first use. You have two charging options: solar charging and charging via the adapter. The built-in solar panel allows the robot to recharge when exposed to direct sunlight.

Solar charging

Place the robot in direct sunlight, and it will automatically begin charging.

Important: Ensure the solar panel is free of dust or debris for optimal charging efficiency.

Note: Charging time may vary depending on sunlight strength. If sunlight is weak, it may take longer to charge.

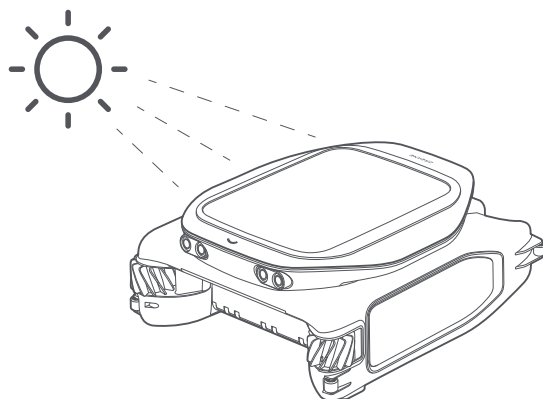

Charging via the adapter

Caution:

- Ensure the charging port is dry before charging.
- Charge the robot in a cool, dry location to prevent hazards.

- 1 Remove the cover from the charging port.
- 2 Connect the adapter to the charging port and plug it into a power outlet.

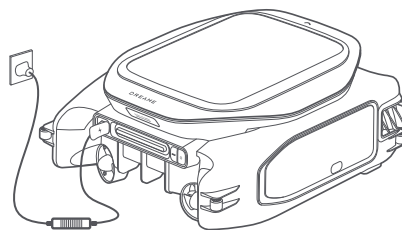
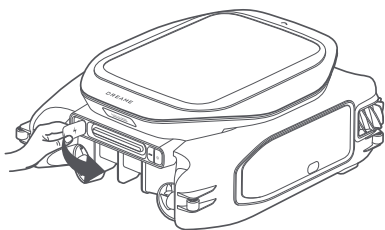

Note: When the indicator light turns solid green, disconnect the charger.

3.2 Install the Dreamehome App

Scan the QR code below to download the Dreamehome app or search for "Dreamehome" in the App Store or Google Play. After installation is complete, please create an account and log in.



OR

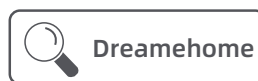

Before setting up the network, please do the following:

- Bring your mobile device close to the robot (within 1 m).
- Enable Bluetooth function on your mobile device.
- Press and hold the Power button for **3** seconds to turn on the robot. Then press and hold the Mode button for **5** seconds to enter pairing mode (blue light flashing rapidly).



3.3 Get Your Robot Online

Prerequisites:

- Ensure that both your mobile device and the robot are within the same Wi-Fi network coverage with a strong signal.
- Ensure the current Wi-Fi network is the single-band network of **2.4** GHz frequency or the dual-band network of **2.4/5** GHz frequency.

① Open Dreamehome app.

② Add your robot in one of the following methods:

- a. Scan QR code to connect: Navigate to  and tap **Scan QR code to connect**. Scan the QR code located either on the top of the robot or inside it. Follow the onscreen instructions to complete the connection.
- b. Add manually: Go to  and tap **Add**. Select your robot model. Follow the onscreen instructions to complete the connection.

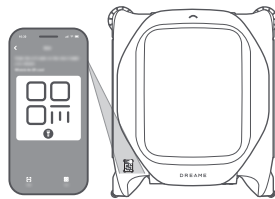
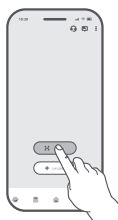

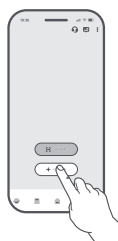

OR



How to unbind the robot?



The robot is automatically bound to the Dreamehome account once pairing is successful. Each device can only be bound to one account. It cannot be bound to another account at the same time.

To pair the robot with a new account, you need to unbind it first. To unbind it:

1. Open the Dreamehome app. Go to .
2. If you have multiple robots bound to your Dreamehome account, swipe left or right to access the page of the robot you want to edit.
3. Tap  in the upper right corner.
4. Select **Delete**.



How to log out of your Dreamehome account or delete it?

To log out or delete your account:

1. Open the Dreamehome app. Go to  >  > **Account**.
2. Select **Log Out** or **Delete Account**.

How to share your robot?

To share your robot with family or friends:

1. Open the Dreamehome app and go to .
2. If you have multiple robots bound to your Dreamehome account, swipe left or right to access the page of the robot you want to share.
3. Tap  in the upper right corner.
4. Select **Device Sharing**.

Note: Dreame development team will continuously conduct **OTA (Over-the-Air)** updates and maintenance on the firmware and app. Please check for update notifications or enable the **Auto-update** function to keep the firmware and app up-to-date and enjoy more features.

4. Operation

4.1 Precautions

Warning: Do not interfere with the robot during operation, as this may cause malfunctions or damage.

Caution:

- Ensure that the pool circulation or heating system is off before cleaning.
- Ensure that there are no foreign objects in the pool before cleaning.
- Avoid animals and people from entering the pool during cleaning.
- Ensure the pool water depth is appropriate for the robot's operation (at least **15 cm**).

4.2 Install Chlorine Tablet (Optional)

Before cleaning, you can install a chlorine tablet into the chlorine dispenser slot. This helps disinfect the pool while the robot is cleaning and ensures the water remains sanitized.

Caution:

- Ensure the robot is powered off before handling the chlorine tablet to avoid any potential accidents.
- Do not overload the robot with chlorine tablets to prevent chemical imbalance or damage to the robot's components.

1 Press the Release button to open the top cover.

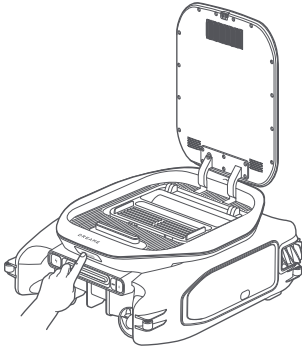

2 Take out the filter basket by the handle.

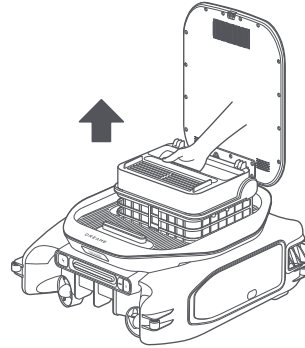

3 Flip the filter basket upside down and turn the cap to open the chlorine dispenser slot.

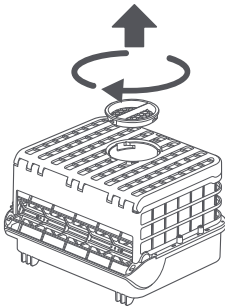

4 Insert the chlorine tablet into the slot.

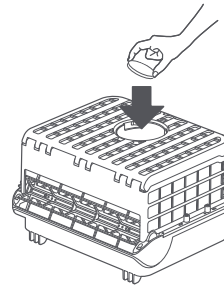

5 Close the chlorine dispenser slot.

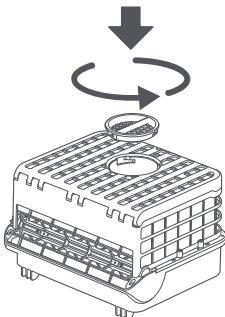

6 Reinstall the filter basket and close the top cover.

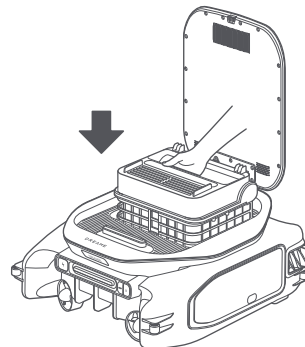

4.3 Start Cleaning

- 1 Press the Power button for 3 seconds to turn on the robot.

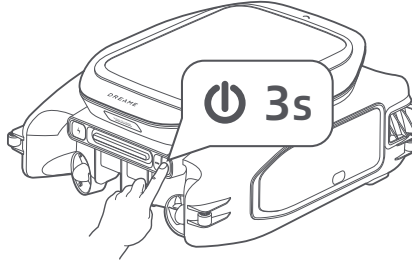

- 2 Select a cleaning mode:
 - a. Press the Mode button to cycle through available modes.
 - b. Alternatively, open the app, choose a mode, and tap **Start**.

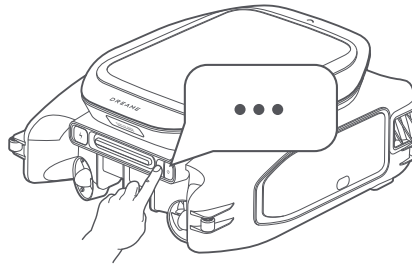

Mode	Coverage
Waterline cleaning	Waterline and corners
Surface cleaning	Water surface only
Combo cleaning	Waterline and water surface

- 3 Place the robot into the pool, and it will begin cleaning automatically.

Note: The robot will clean until the battery runs low. If there is sunlight, it will recharge itself and continue cleaning.

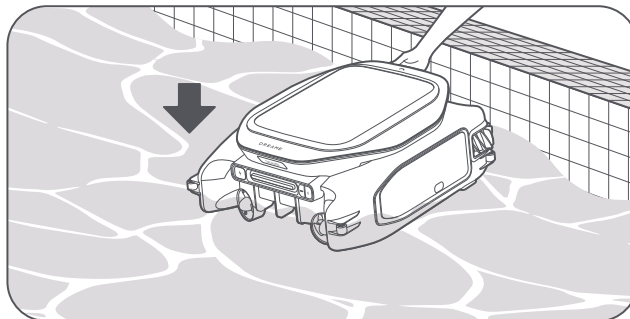

4.4 Retrieve the Robot

- 1 To finish cleaning, activate Remote Mode in the app and tap Park  to bring the robot to the poolside.

Important: Ensure that both your phone and the robot are connected to the same Wi-Fi network with a strong signal. For Bluetooth control, keep your phone within 10 m of the robot.

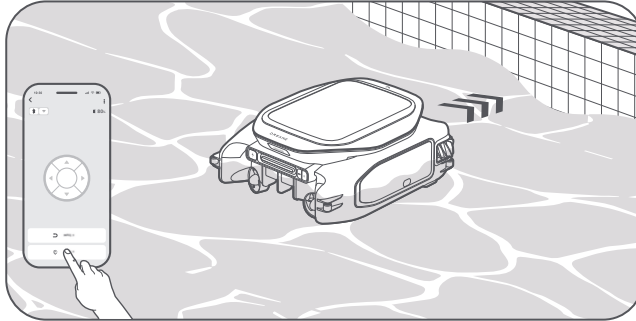

- 2 Grab the handle to lift the robot out of the pool and drain any remaining water from it.

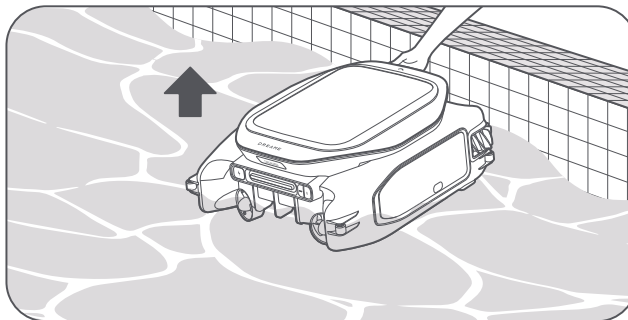

Note: You can also use the directional controls in the app to guide the robot to an accessible location for retrieval. Use the retrieval hook if needed.

4.5 Eco Mode

When the battery level drops below **20%**, the indicator light turns orange, and the robot switches to Eco Mode. In this mode, the robot works intermittently. Only the debris intake impeller and propellers remain active to conserve power.

If sunlight is available, the robot will use solar tracking to move to a sunlit area in the pool for charging. Once sufficiently charged, the robot will resume its previous cleaning task.

Note: Eco Mode is automatically managed by the robot and requires no manual intervention.

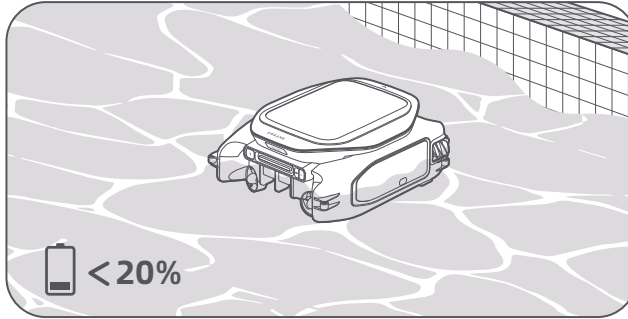

4.6 Anti-stranding Bars

When to use: Deploy the anti-stranding bars if the pool has shallow steps or obstacles that may trap the robot.

How to use: Rotate the bars outward to activate them. To retract, rotate them back into place.

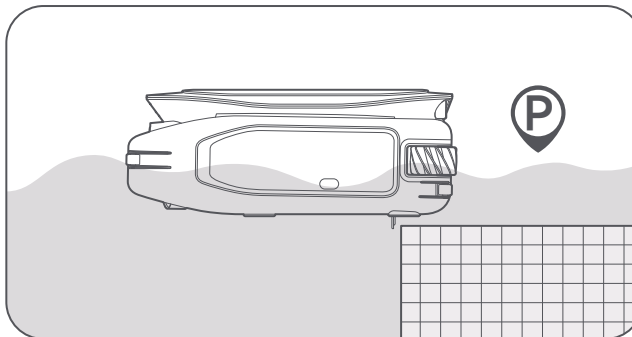
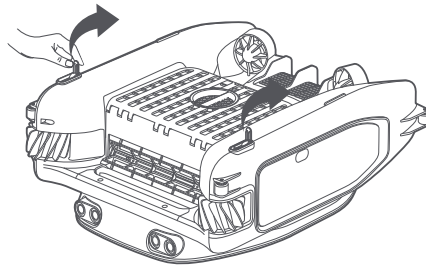

5. Maintenance

Note: Always power off the robot before performing any maintenance to prevent accidental operation.

Clean Filter Basket

After each use, it is recommended to clean the filter basket for optimal cleaning performance.

❶ Push the Release button to open the top cover.

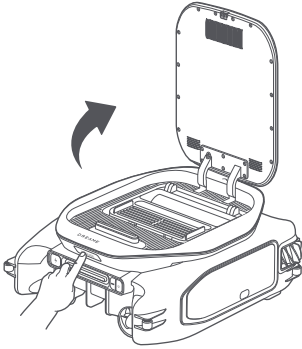

❷ Take out the filter basket by the handle.

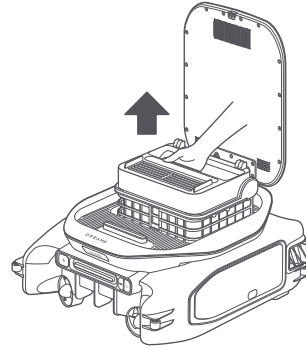

❸ Clean the debris intake impeller.

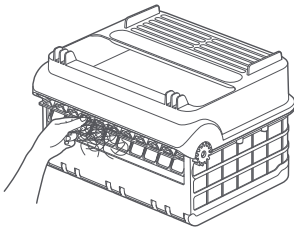

❹ Open the latch to release the bottom lid of the filter basket. Empty all debris such as leaves, algae, and hair.

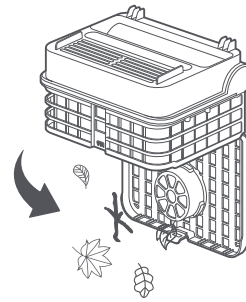

❺ Rinse the filter basket thoroughly with a hose.

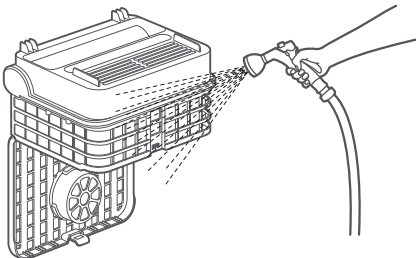

❻ Put the filter basket back into the robot.

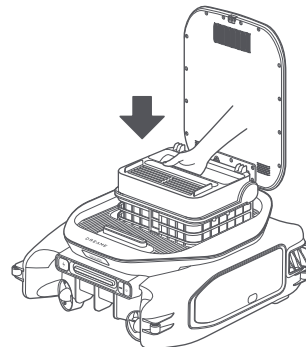

- 7 Close the top cover.

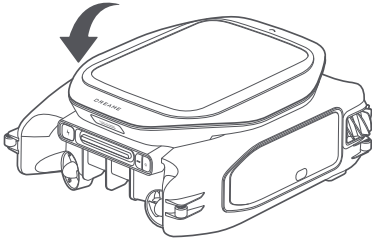

Clean Side Brushes

- 1 Unwrap and remove the side brush from the robot.
- 2 Remove all entanglements from it before reinstalling.

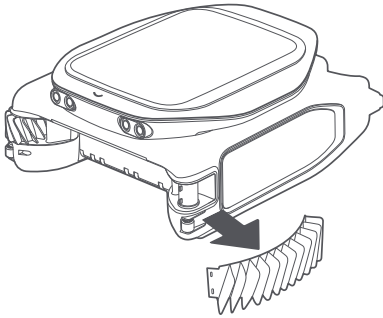

Clean Solar Panel and Ultrasonic Sensors

Use a soft, dry cloth to wipe the solar panel and ultrasonic sensors.

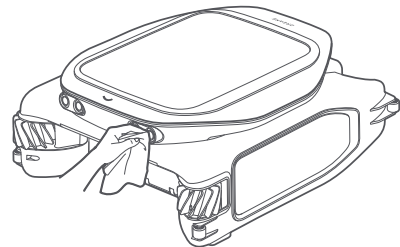
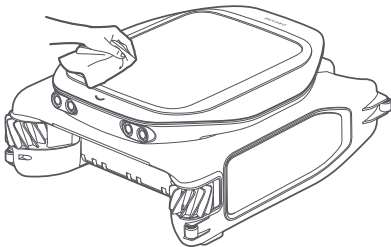

Clean Propellers

Check that the propellers are clear of any debris that may cause an obstruction.

Important: Make sure the charging port and sensors are completely dry after cleaning the robot.

Note: If replacements are necessary, please reach out to the after-sales service for further assistance.

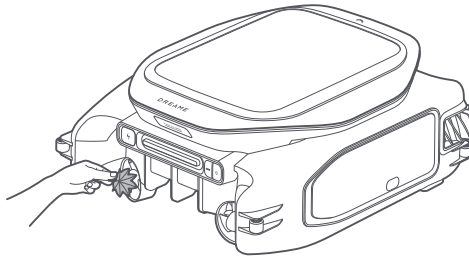

6. Off-Season Storage

Store the robot properly during long breaks to maintain its performance and durability.

Note: Charge the battery to at least 80% before storing the robot. For long-term storage, charge it every 6 months to maintain battery health.

- 1 Remove the robot from the pool and drain any remaining water.
- 2 Turn off the robot by pressing the Power button for 3 seconds.
- 3 Clean the robot thoroughly, removing any debris, dust, or residues, and ensure it is completely dry.
- 4 Store the robot in a dry, cool place.

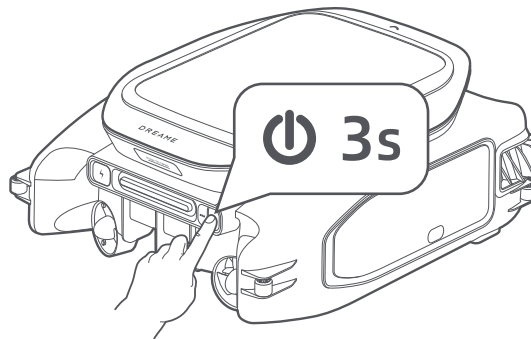
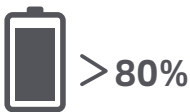

7. Troubleshooting

Issues	Causes	Solutions
The robot fails to connect to the app.	<ol style="list-style-type: none"> 1. There may be an issue with the robot's wireless communication or Bluetooth. 2. The router or phone may be too far from the robot. 	<ol style="list-style-type: none"> 1. Ensure the wireless router is functioning properly. 2. Keep the robot within 10 meters of your phone for Bluetooth pairing. 3. If the issue persists, contact after-sales service.
The robot fails to move along the pool wall.	<ol style="list-style-type: none"> 1. Sensors may be blocked by debris or malfunctioning. 2. External factors such as waves or wind may interfere. 	<ol style="list-style-type: none"> 1. Clean all sensors thoroughly and try again. 2. Note that waves or wind may affect wall-following performance. 3. If the issue persists, contact after-sales service.
The robot fails to move in an S-shaped pattern while cleaning the water surface.	<ol style="list-style-type: none"> 1. Sensors may be blocked by debris or malfunctioning. 2. External factors such as waves or wind may interfere. 	<ol style="list-style-type: none"> 1. Clean all sensors thoroughly and try again. 2. Note that waves or wind may disrupt the S-shaped path. 3. If the issue persists, contact after-sales service.
Solar charging fails.	<ol style="list-style-type: none"> 1. Sunlight may be too weak to charge the robot with the solar panel. 2. The solar panel may be malfunctioning. 3. The robot's battery may be overheating. 	<ol style="list-style-type: none"> 1. Move the robot to a place with sufficient sunlight. 2. Check the solar panel for any damage. 3. Place the robot in a cool, dry location and allow it to cool down before trying again. 4. If the issue persists, contact after-sales service.
The robot fails to charge using the adapter.	<ol style="list-style-type: none"> 1. The charging port may be wet. 2. The charging connector may be damaged. 3. The robot's battery may be overheating. 	<ol style="list-style-type: none"> 1. Wipe the charging port dry and try again. 2. Place the robot in a cool, dry location. Allow it to cool down before trying again. 3. If the issue persists, contact after-sales service.
The robot is unable to move or is moving slowly on the water surface.	<ol style="list-style-type: none"> 1. Sensors may be blocked by debris or malfunctioning. 2. External factors such as waves or wind may interfere. 3. The robot's battery is overheating. 	<ol style="list-style-type: none"> 1. Clean all sensors thoroughly. 2. Note that waves or wind may reduce the robot's movement speed. 3. Place the robot in a cool, dry location and allow it to cool down before trying again. 4. If the issue persists, contact after-sales service.

Issues	Causes	Solutions
The robot works intermittently.	<ol style="list-style-type: none"> 1. The battery may be low (15% to 20%) and the robot is in Eco mode. 2. External factors such as waves or wind may interfere. 	<ol style="list-style-type: none"> 1. Charge the robot to ensure sufficient power. 2. The robot is designed to work intermittently in Eco mode. 3. Be aware that waves or wind may cause the robot to stop periodically. 4. If the issue persists, contact after-sales service.
The cleaning results are not as good as expected.	<ol style="list-style-type: none"> 1. The filter basket may be full. 2. Side brushes or debris intake impeller may be clogged with debris. 3. External factors such as waves or wind may interfere. 	<ol style="list-style-type: none"> 1. Empty the filter basket and try again. 2. Ensure that the side brushes and debris intake impeller are free of debris or entanglements. 3. Note that waves or wind may affect cleaning performance.
The robot is stuck.	The robot is stuck and unable to free itself.	<ol style="list-style-type: none"> 1. Use the app's remote mode to move the robot away from any obstruction. 2. Manually retrieve the robot and restart the cleaning cycle.
The LED indicator shows red after cleaning is started.	<ol style="list-style-type: none"> 1. There may be an issue with the sensors. 2. There may be an issue with propellers, side brushes, and debris intake impeller. 	<ol style="list-style-type: none"> 1. Clean the sensors and check for obstructions in the propellers, side brushes, or debris intake impeller. 2. If the issue persists, contact after-sales service.
The app displays errors related to propellers, side brushes, or debris intake impeller.	<ol style="list-style-type: none"> 1. Debris may be tangled in the propellers, side brushes, or debris intake impeller. 2. Salt deposits may have accumulated on the propellers. 	<ol style="list-style-type: none"> 1. Clear any debris from propellers, side brushes, and debris intake impeller, then try again. 2. Clean the propellers thoroughly before trying again. 3. If the issue persists, contact after-sales service.
The robot cannot be powered on.	<ol style="list-style-type: none"> 1. The robot battery may be too low. 2. The robot battery may be overheating. 	<ol style="list-style-type: none"> 1. Charge the robot to ensure sufficient power. 2. Place the robot in a cool, dry location. Allow it to cool down before trying again. 3. If the issue persists, contact after-sales service.

8. Specifications

Product Name	J1 Robotic Pool Skimmer
Brand	Dreame
Model	PNUJ4110
Dimensions (W×L×H)	486 x 560 x 220mm
Cleaning Speed	15cm/s
Working Voltage	14.4V
Charger Model	EU: GM39-200150-2DG AU: GM39-200150-4DG
Charger Input	100 ~ 240VAC
Charger Output	21.5VDC
Battery	5200mAh/72Wh
Operation Temperature	5-40°C (41-104 °F)
Charging Temperature	0 ~ 40°C
Storage Temperature	-20 ~ 55°C
Motor Type	BLDC
Charging Time	4 hrs
Filter Basket Capacity	5L
Degree of Protection	IPX8 (Water depth1.5m, 1h)
Cleaning Mode	Surface, Waterline, Combo

Standards	Frequency band
Bluetooth	2402 - 2480 MHz
WiFi (20MHz)	2412 - 2462 MHz

* The above statistics are from Dreame Laboratory and may vary depending on the operating conditions.