

SET ELEGANCE 45 1D

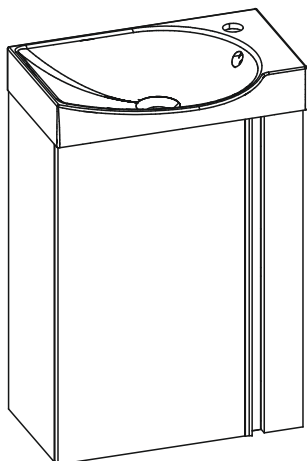
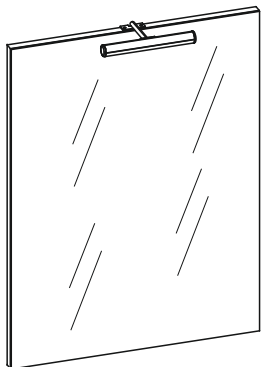

Podczas wiercenia należy stosować odpowiedni sprzęt ochronny (okulary ochronne, ochrona słuchu).

Beim Bohren entsprechende Schutzrüstung (Schutzbrille, Gehörschutz) tragen.

Wear appropriate protective equipment when drilling (safety goggles, ear protection).



Urządzenia elektroniczne są odpadami nadającymi się do recyklingu i nie wolno ich utylizować wyrzucając ich do śmieci domowych. Na końcu ich żywotności, należy go utylizować zgodnie z przepisami i obowiązującymi wytycznymi.

Elektronische Geräte sind Wertstoffe und gehören nicht in den Hausmüll. Entsorgen Sie das Produkt am Ende seiner Lebensdauer gemäß den geltenden gesetzlichen Bestimmungen.

Electronic devices are recyclable waste and must not be disposed of in the household waste. At the end of its service life, dispose of the product in accordance with applicable regulatory guideline.

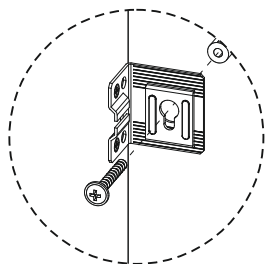

x2

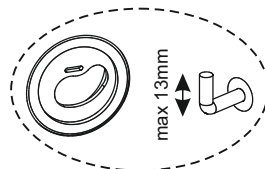
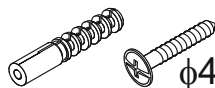



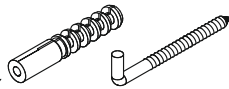





x2



Karta Gwarancyjna
Warranty card
Garantiekarte

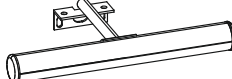

EN Caution: Always use appropriate fixings to suit your type of wall. / **ES ¡Atención!** Use siempre las fijaciones apropiadas dependiendo del tipo de pared. / **FR ! Attention:** Utilisez toujours une fixation adaptée à votre type de mur. / **DE Achtung:** Bitte verwenden Sie für ihr Mauerwerk geeignetes Befestigungsmaterial. / **IT Attenzione:** I fissaggi devono essere scelti a seconda del tipo di muro. / **PL Uwaga:** Stosuj mocowania ściennie odpowiednie do rodzaju ściany. / **NL Waarschuwing:** gebruik altijd bevestigingsmaterialen die geschikt zijn voor uw wand-type. / **BG Внимание:** Винаги използвайте подходящи крепежни елементи, според вида на стената. / **RU Внимание:** Всегда используйте подходящий для Вашего типа стены крепеж. / **GR Προσοχή:** Για την καλύτερη εγκατάσταση προτείνουμε να χρησιμοποιείτε πάντα τα κατάλληλα στηρίγματα. / **CZ Pozor:** Použijte prosím takové montážní prvky, které odpovídají typu stěny. / **RO Atenție:** Elementele de fixare trebuie să fie alese în funcție de tipul de perete. / **LT Įspėjimas:** Visada naudokite tinkamus tvirtinimo elementus, atitinkančius jūsų sienos tipą. / **EE Ettevaatus:** Kasutage alati sobivaid kinnitusi, mis sobivad teie seinatüübiga. / **LV Uzmanību:** Vienmēr izmantojiet piemērotus stiprinājumus, kas atbilst jūsu sienas tipam. / **CRO Napomena:** Uvijek koristite odgovarajuće pričvršćivanja koja odgovaraju vašem tipu zida. / **HU Figyelem:** Mindig a fal típusnak megfelelő rögzítést használjon. / **SLO Pozor:** Vedno uporabite ustrezne pritrdilne elemente glede na tip stene.

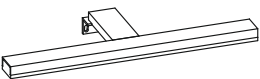
R1	R8	R9	N5	LED	
				Zródło światła niniejszej oprawy oświetleniowej jest niewymienne. Die Lichtquelle dieser Leuchte kann nicht ersetzt werden. The light source of this luminaire is not replaceable.	
x 4	x 2	11x5 x 4	US3,5x16 x 3	 x2	
					
ø5 x 8	x 4	x 2		Dieses Produkt enthält eine Lichtquelle der Energieeffizienzklasse G	
		x 1		x 1	

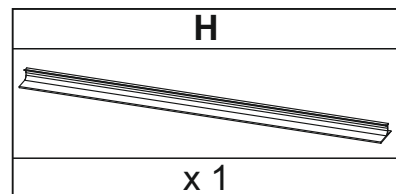
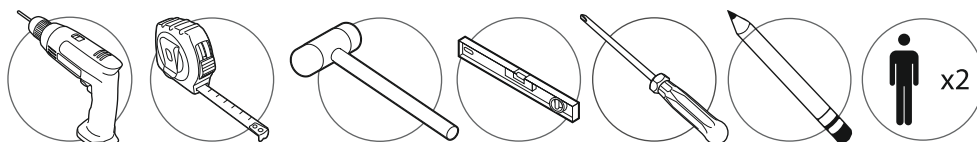

01.

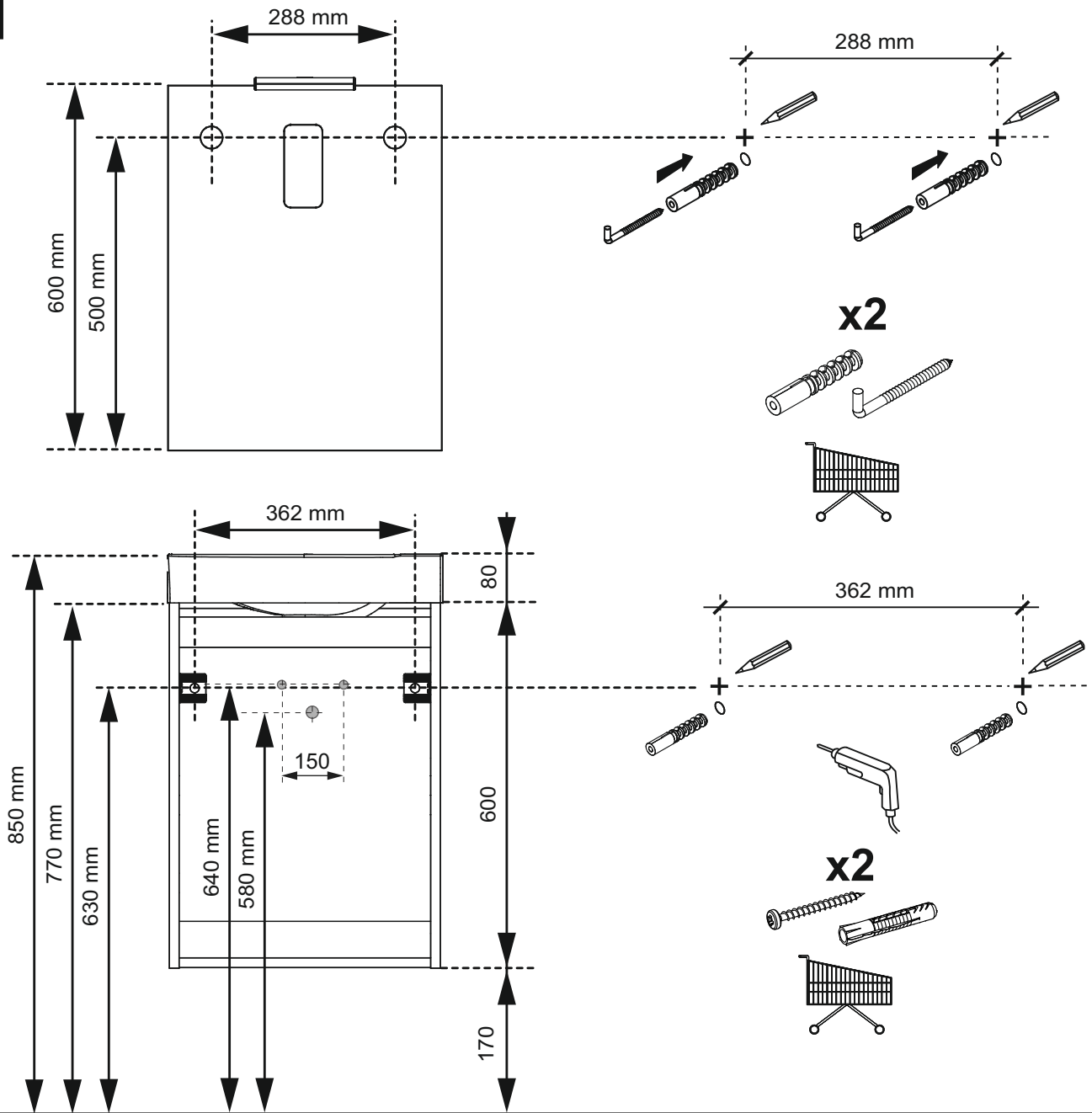

02.

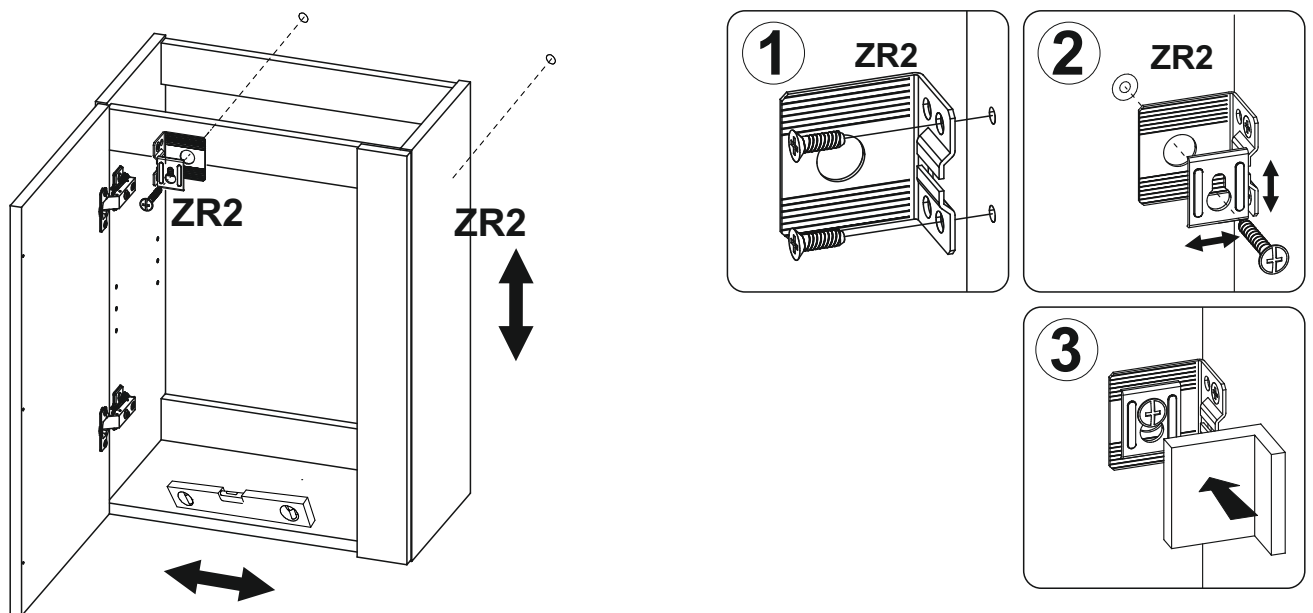

03.

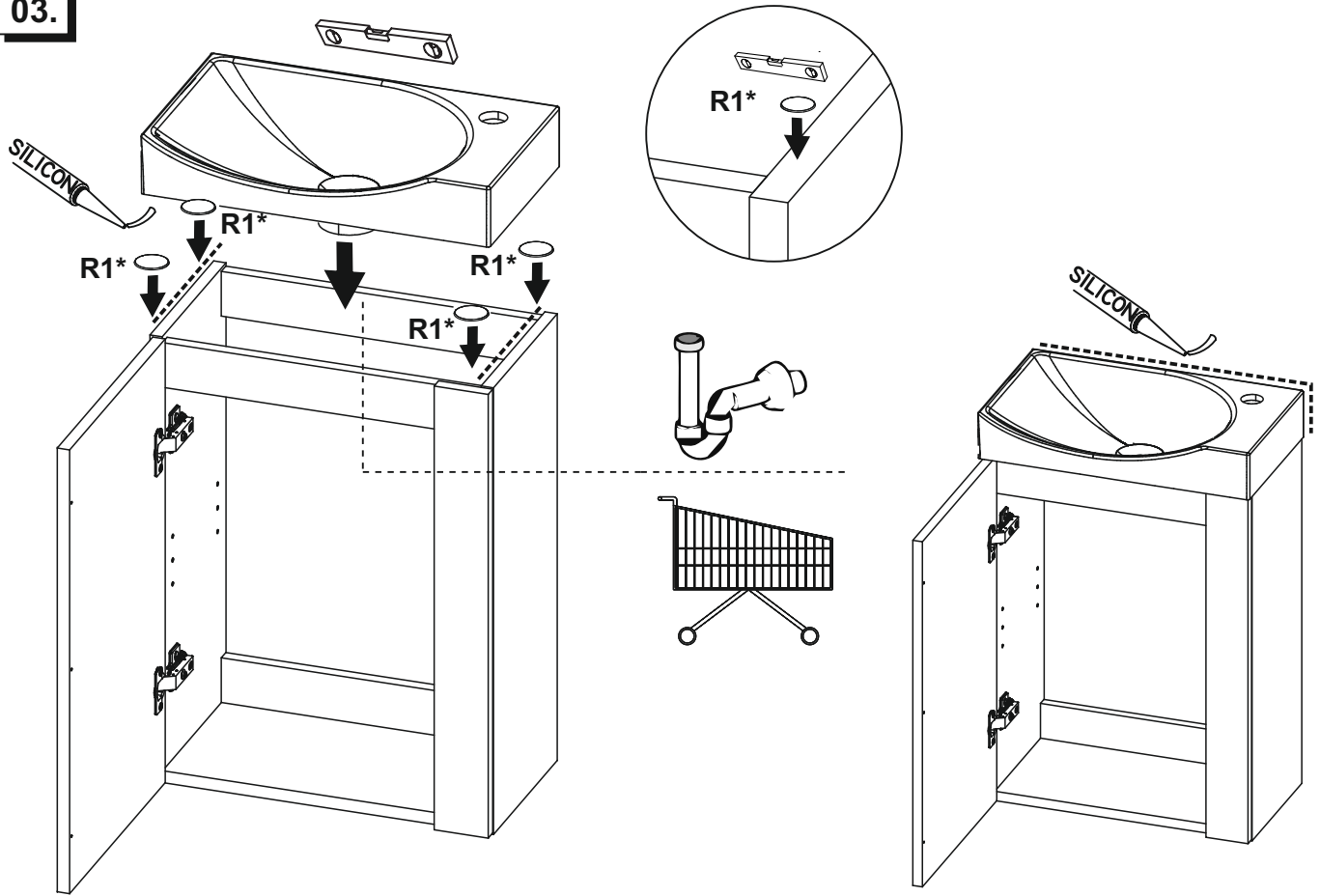

04.

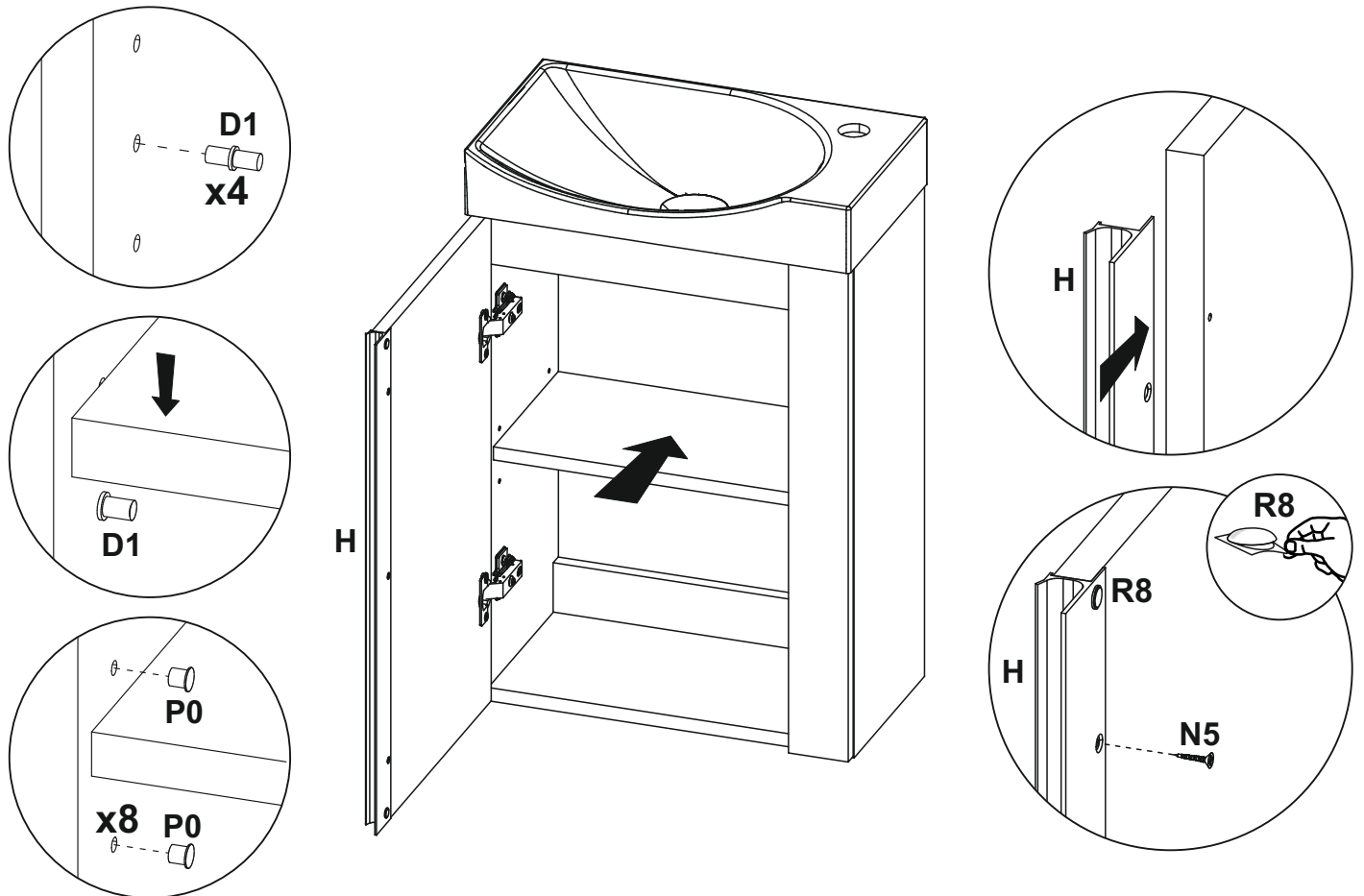

05.

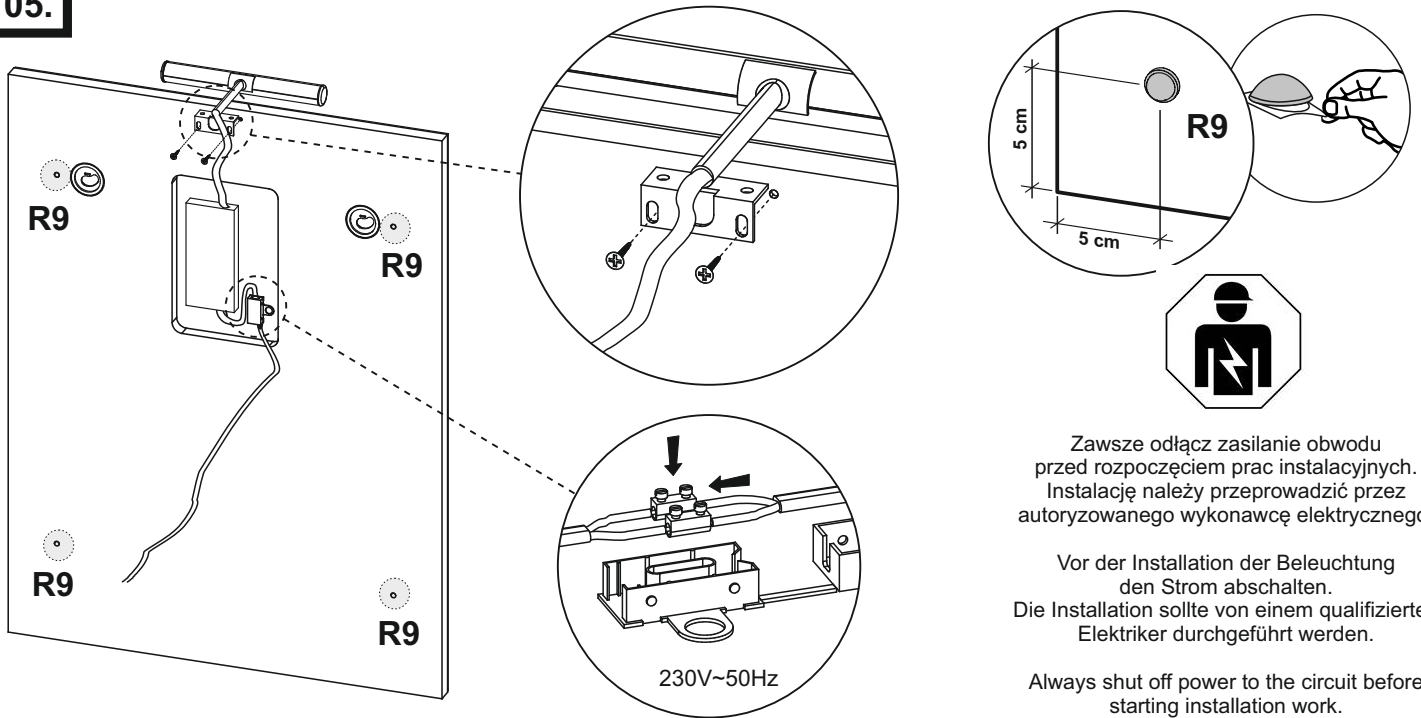

Zawsze odłącz zasilanie obwodu przed rozpoczęciem prac instalacyjnych. Instalację należy przeprowadzić przez autoryzowanego wykonawcę elektrycznego.

Vor der Installation der Beleuchtung den Strom abschalten. Die Installation sollte von einem qualifizierten Elektriker durchgeführt werden.

Always shut off power to the circuit before starting installation work. The installation shall be carried out by an authorized electrical contractor.

06.

