

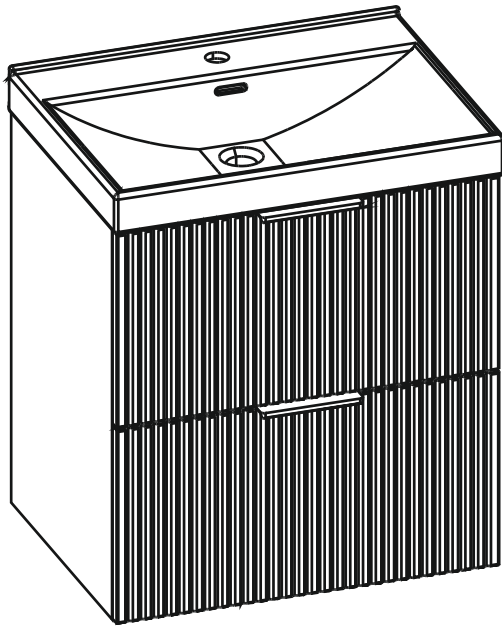

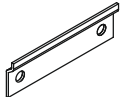

YASUMI

60 2DR

80 2DR

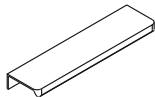

P11  x 2	R1  x 4	SF1  x 1	H  x 2	N5  US3,5x16 x 4
--	---	--	--	---

EN Caution: Always use appropriate fixings to suit your type of wall. / **ES ¡Atención!** Use siempre las fijaciones apropiadas dependiendo del tipo de pared. / **FR ! Attention:** Utilisez toujours une fixation adaptée à votre type de mur. / **DE Achtung:** Bitte verwenden Sie für ihr Mauerwerk geeignetes Befestigungsmaterial. / **IT Attenzione:** I fissaggi devono essere scelti a seconda del tipo di muro. / **PL Uwaga:** Stosuj mocowania ściennie odpowiednie do rodzaju ściany. / **NL Waarschuwing:** gebruik altijd bevestigingsmaterialen die geschikt zijn voor uw wand-type. / **BG Внимание:** Винаги използвайте подходящи крепежни елементи, според вида на стената. / **RU Внимание:** Всегда используйте подходящий для Вашего типа стены крепеж. / **GR Προσοχή:** Για την καλύτερη εγκατάσταση προτείνουμε να χρησιμοποιείτε πάντα τα κατάλληλα στηρίγματα. / **CZ Pozor:** Použijte prosím takové montážní prvky, které odpovídají typu stěny. / **RO Atenție:** Elementele de fixare trebuie să fie alese în funcție de tipul de perete. / **LT Įspėjimas:** Visada naudokite tinkamus tvirtinimo elementus, atitinkančius jūsų sienos tipą. / **EE Ettevaatus:** Kasutage alati sobivaid kinnitusi, mis sobivad teie seinatüübiga. / **LV Uzmanību:** Vienmēr izmantojiet piemērotus stiprinājumus, kas atbilst jūsu sienas tipam. / **CRO Napomena:** Uvijek koristite odgovarajuće pričvršne elemente koji odgovaraju vašoj vrsti zida. / **RS Opresz:** Uvek koristite odgovarajuća pričvršćivanja koja odgovaraju vašem tipu zida. / **HU Figyelem:** Mindig a falípusnak megfelelő rögzítést használjon. / **SLO Pozor:** Vedno uporabite ustrezne pritrdilne elemente glede na tip stene.

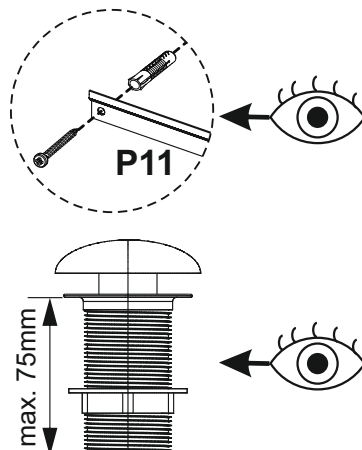
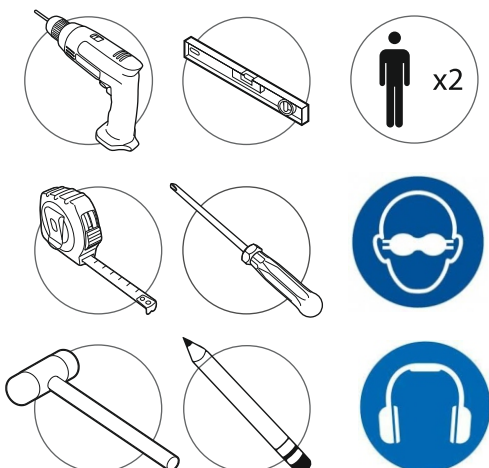

Podczas wiercenia należy stosować odpowiedni sprzęt ochronny (okulary ochronne, ochrona słuchu).

Beim Bohren entsprechende Schutzausrüstung (Schutzbrille, Gehörschutz) tragen.

Wear appropriate protective equipment when drilling (safety goggles, ear protection).

01.

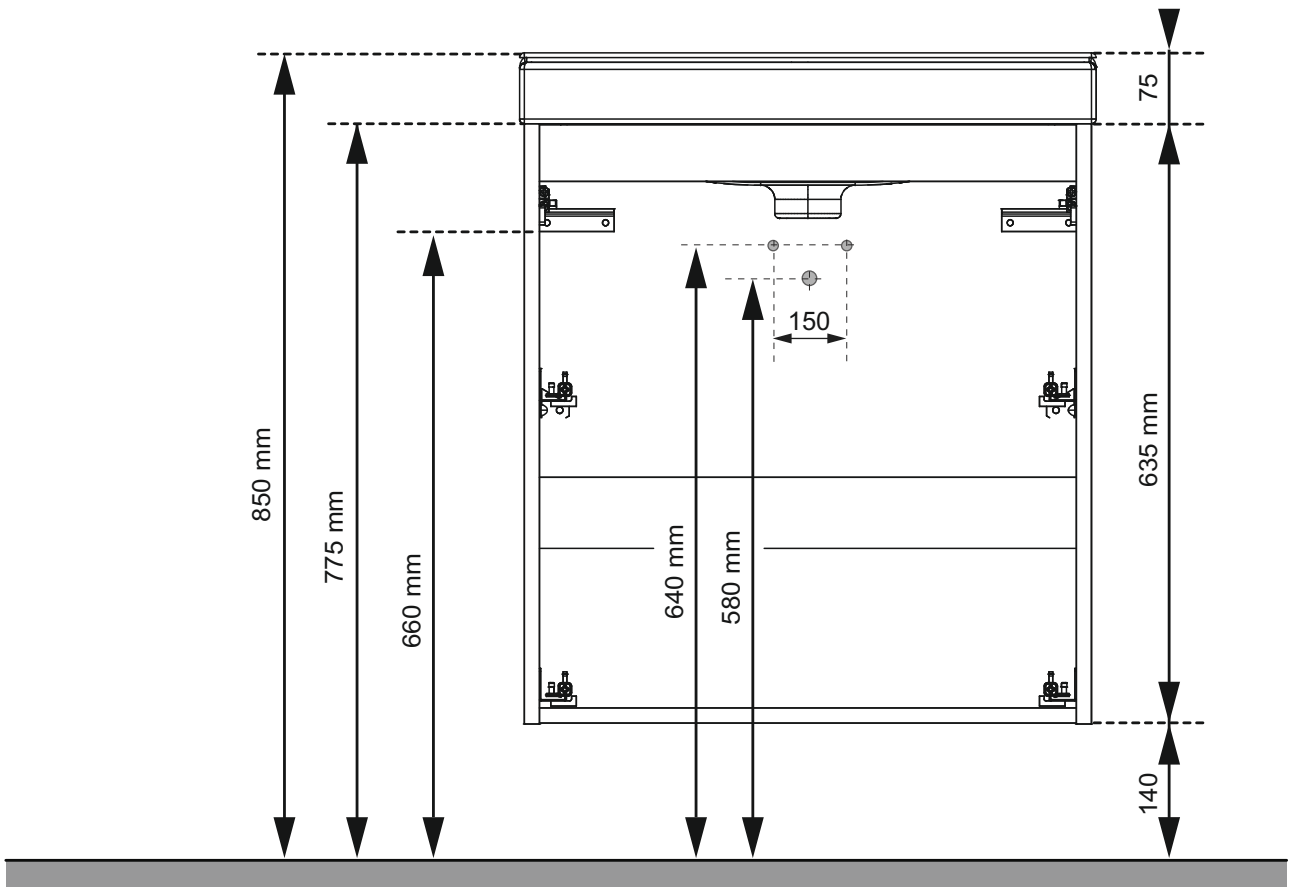

02.

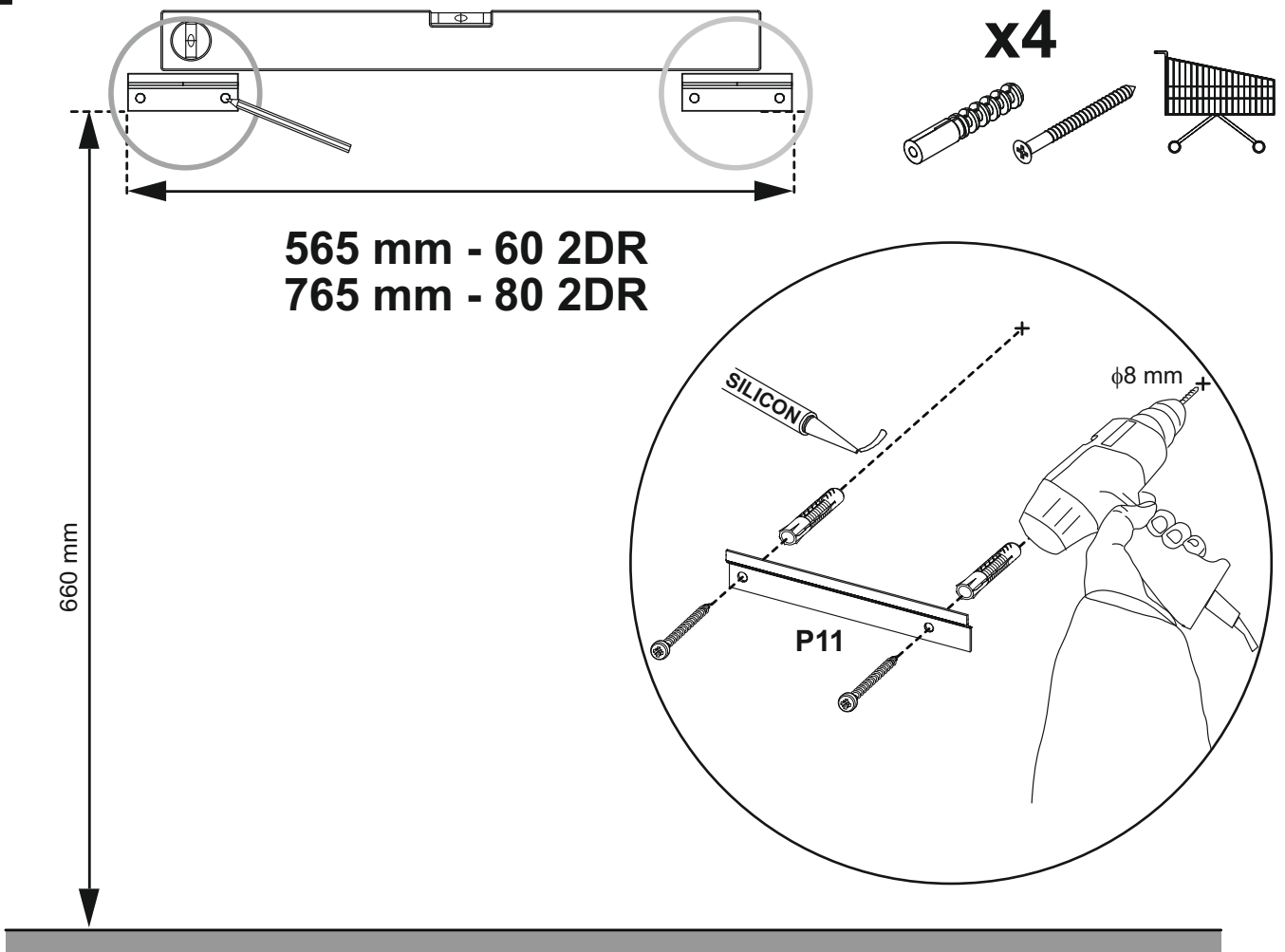

03.

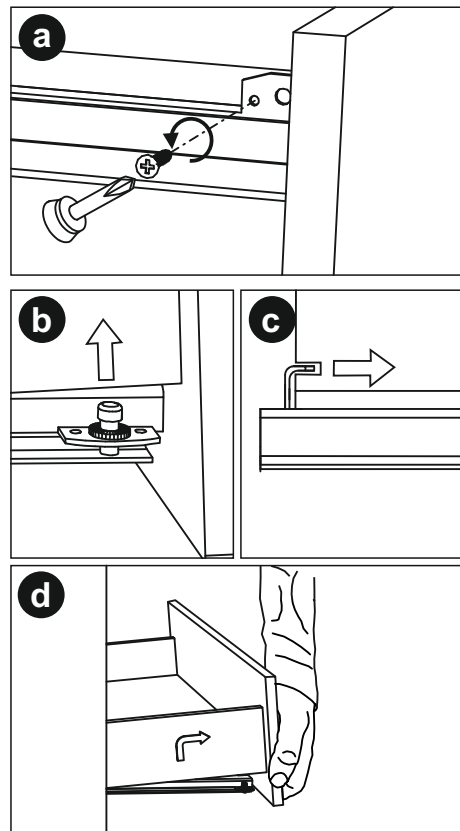
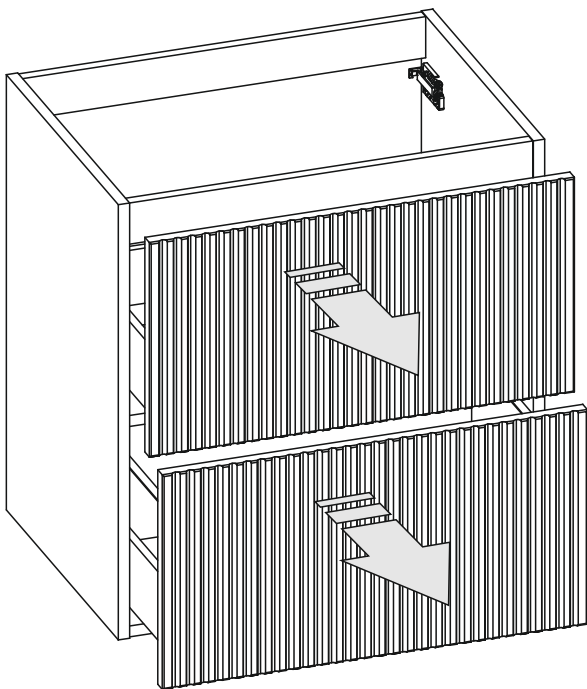

04.

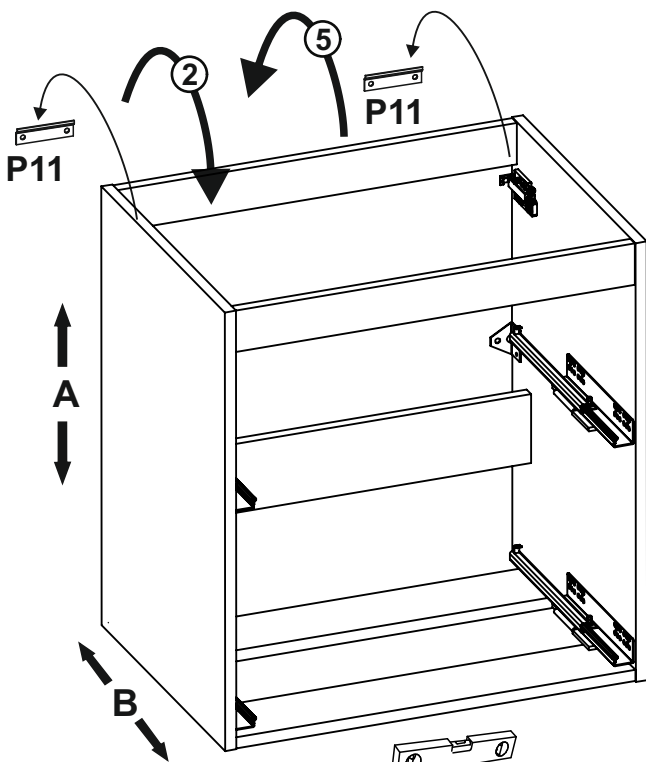

x2

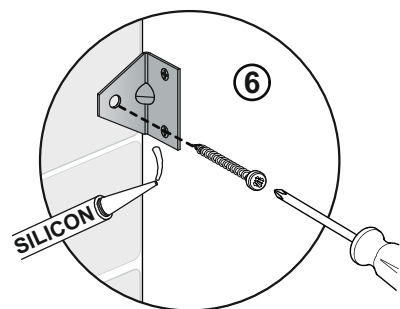
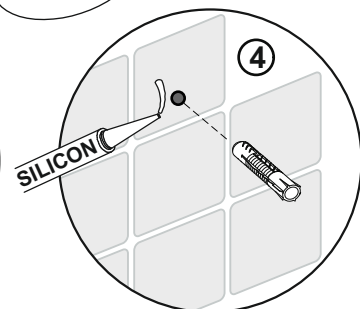
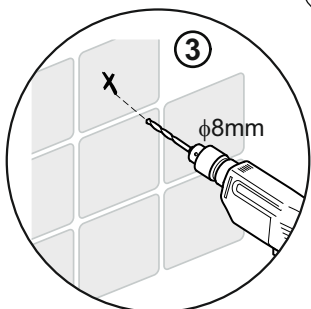
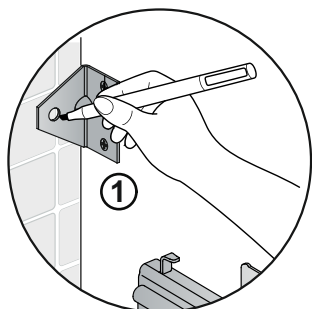
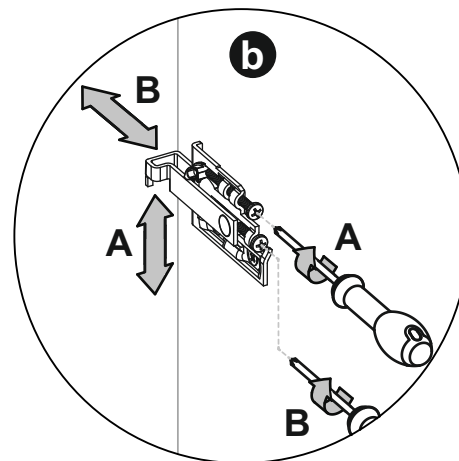
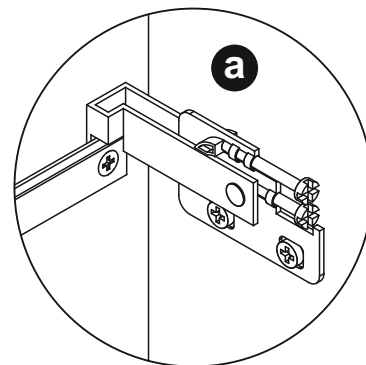

05.

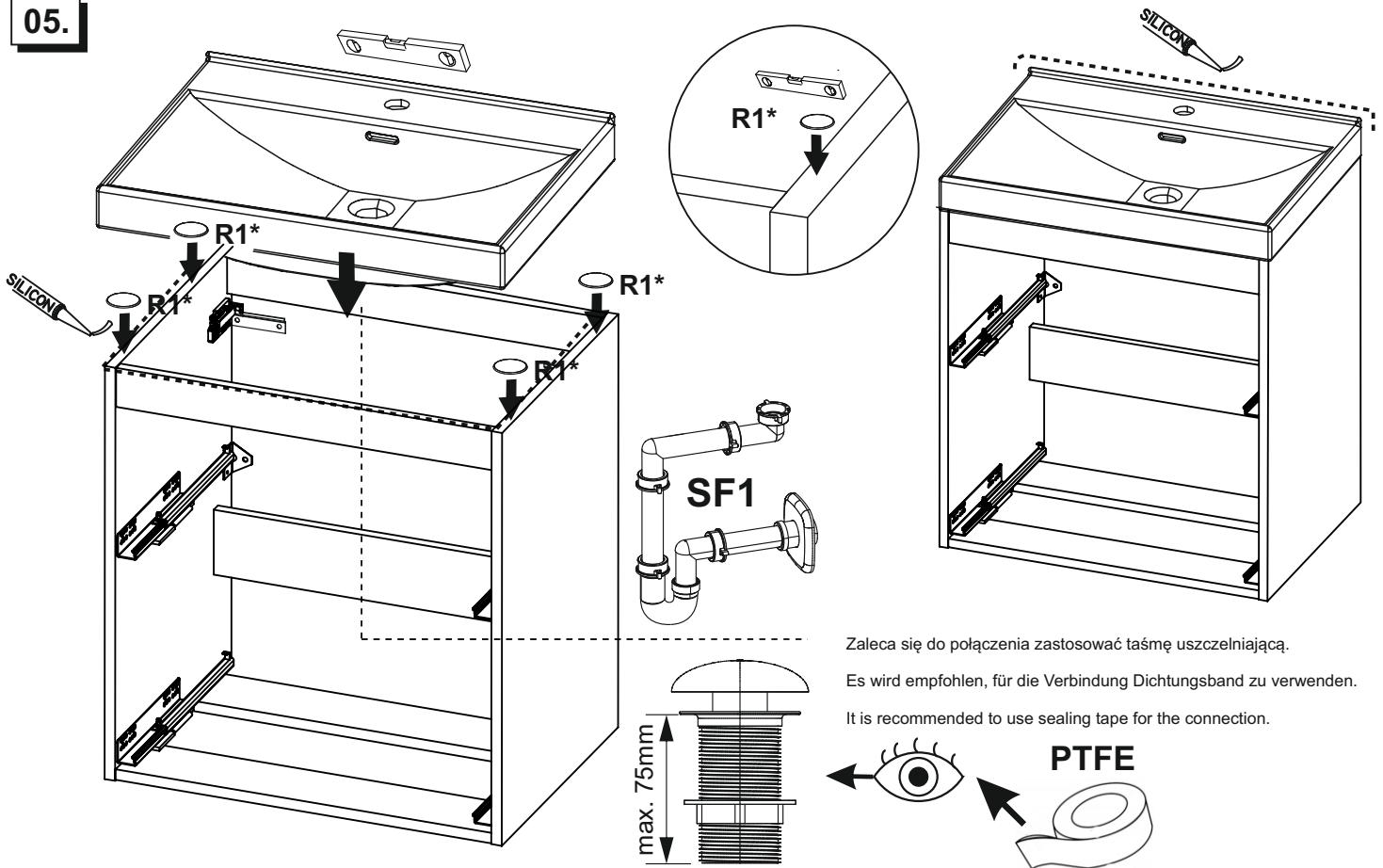

Zaleca się do połączenia zastosować taśmę uszczelniającą.
 Es wird empfohlen, für die Verbindung Dichtungsband zu verwenden.
 It is recommended to use sealing tape for the connection.

06.

