



Wasser erleben

HANSAPINTO

INSTALLATION AND MAINTENANCE GUIDE



Contents

CZ Obsah	FI Sisällysluettelo	IT Indice	PT Conteúdo
DE Inhaltsübersicht	FR Sommaire	NL Inhoud	RU Содержание
DK Indholdsfortegnelse	GR Περιεχόμενα	NO Innhold	SE Innehållsförteckning
ES Contenidos	HU Tartalom	PL Spis treści	SK Obsah



Technical data	4-5
Installation	7-9
Operation.....	11
Maintenance.....	11-15
Spare parts.....	16-17

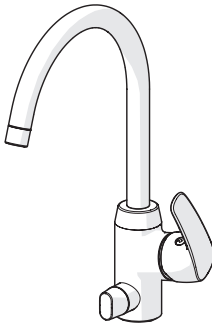

Technical data	5-6
Installation	10
Operation.....	11
Maintenance.....	11-17
Spare parts.....	17-18

4508 2283

EN 817
50 -1000 kPa
0.2 l/s (300 kPa)
max. +80°C

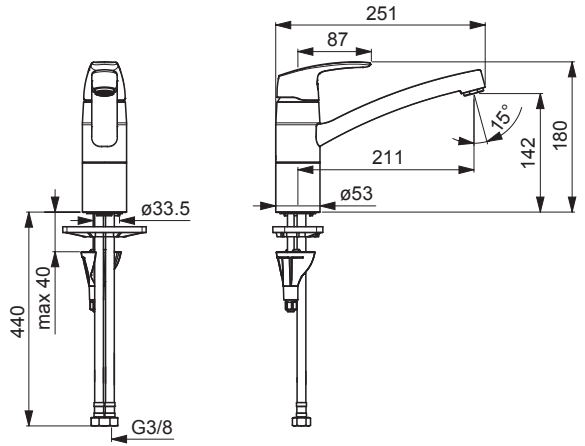

4520 2283

EN 817
50 -1000 kPa
0.2 l/s (300 kPa)
max. +80°C

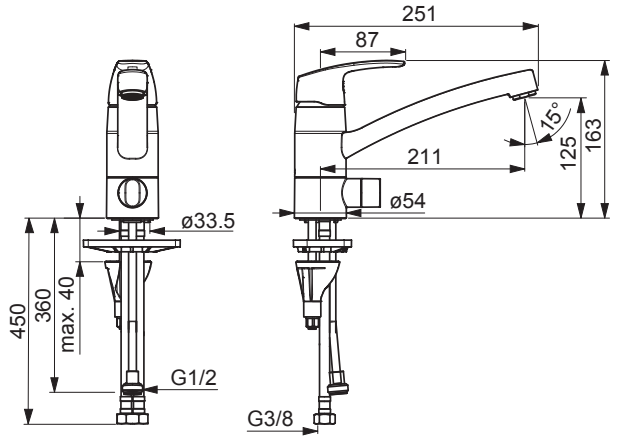

4538 1183

EN 817
50 -500 kPa
max. +80°C

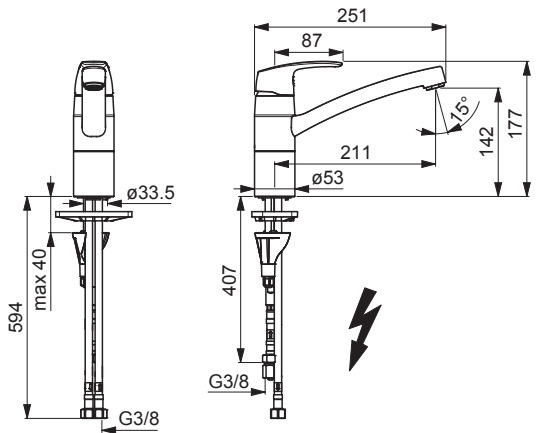

4518 2283

EN 817
50 -1000 kPa
0.16 l/s (300 kPa)
max. +80°C

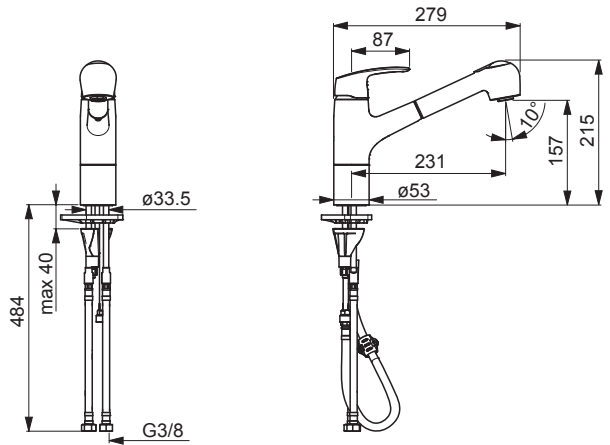

4508 2283 0037

EN 817
50 -1000 kPa
0.2 l/s (300 kPa)
max. +80°C

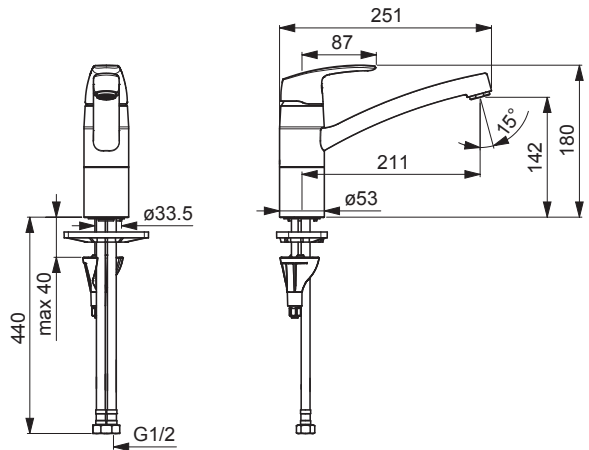

4513 2283

EN 817
50 -1000 kPa
0.2 l/s (300 kPa)
max. +80°C

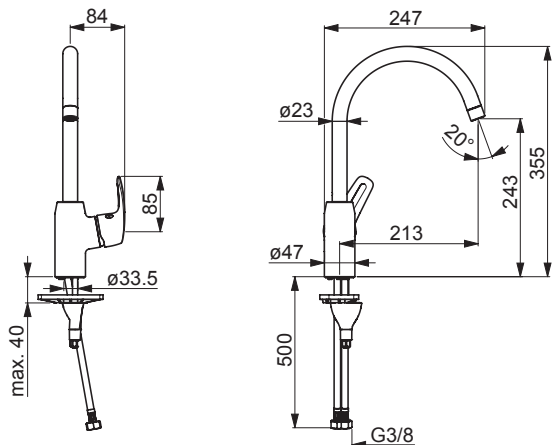

4514 2283

EN 817
50 -1000 kPa
0.2 l/s (300 kPa)
max. +80°C

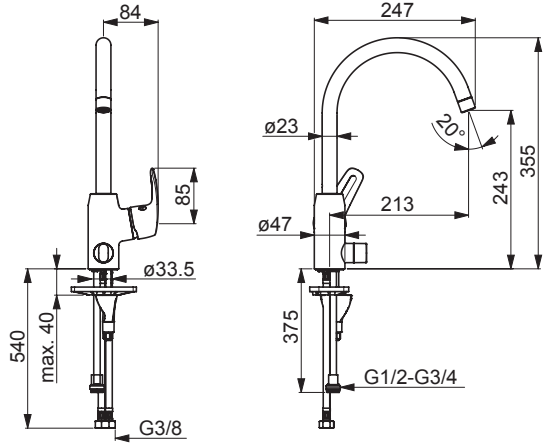

4513 2283 0037

EN 817
50 -1000 kPa
0.2 l/s (300 kPa)
max. +80°C

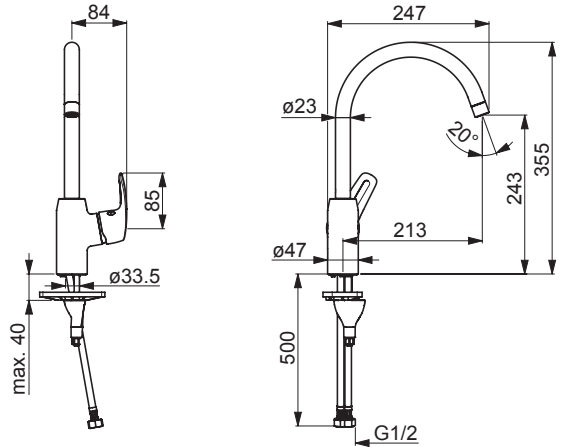

Installation

CZ Montáž
DE Montage
DK Installation
ES Montaje

FI Asennus
FR Installation
GR Συναρμολόγηση
HU Szerelés

IT Montaggio
NL Installatie
NO Montering
PL Instalacja

PT Instruções
RU Установка
SE Installation
SK Inštalácia

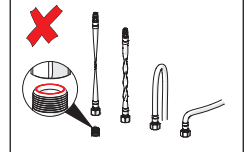
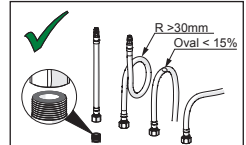
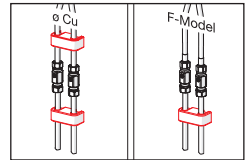
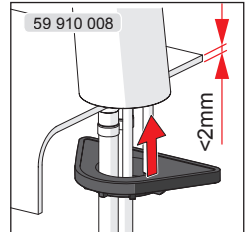
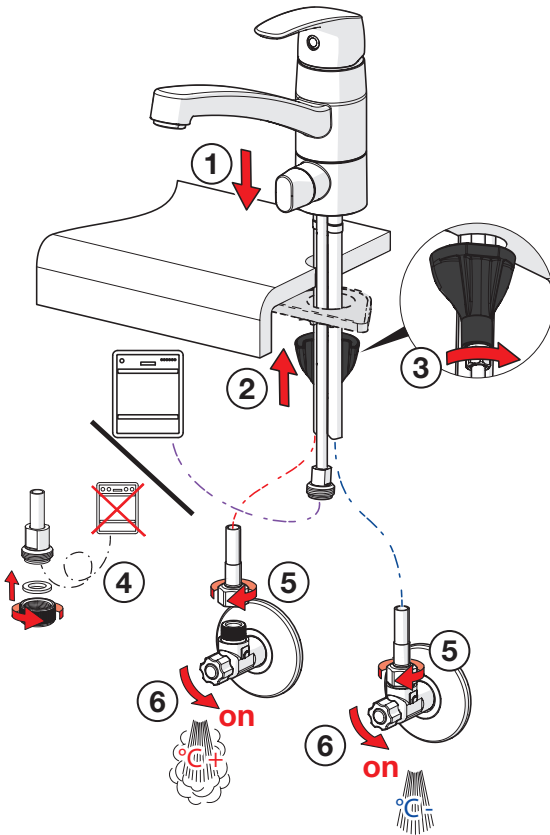
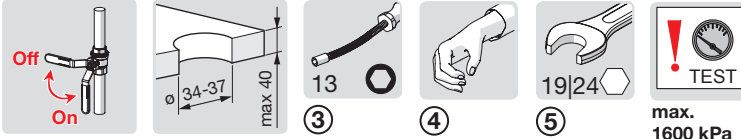

Installation

CZ Montáž

DE Montage

DK Installation

ES Montaje

FI Asennus

FR Installation

GR Συναρμολόγηση

HU Szerelés

IT Montaggio

NL Installatie

NO Montering

PL Instalacja

PT Instruções

RU Установка

SE Installation

SK Inštalácia

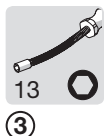
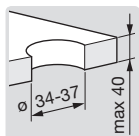

max.
1600 kPa

4538 1183

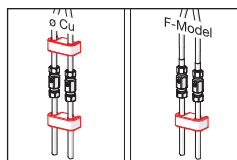
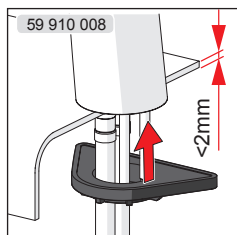
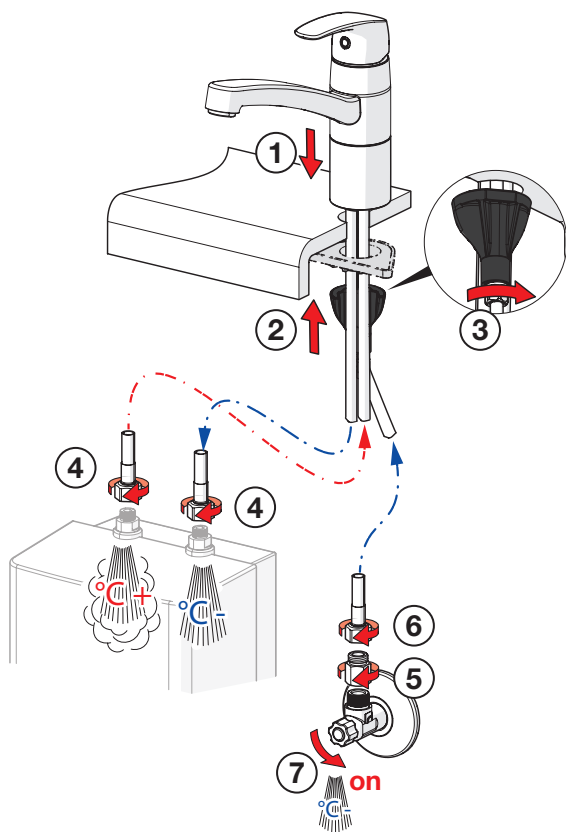

Installation

CZ Montáž
DE Montage
DK Installation
ES Montaje

FI Asennus
FR Installation
GR Συναρμολόγηση
HU Szerelés

IT Montaggio
NL Installatie
NO Montering
PL Instalacja

PT Instruções
RU Установка
SE Installation
SK Inštalácia

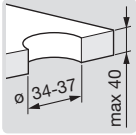
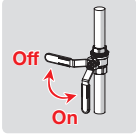

max.
1600 kPa

4518 2283

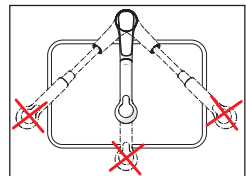
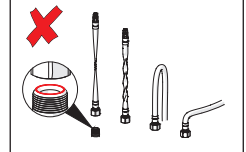
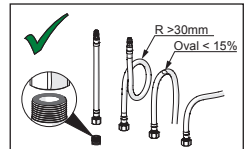
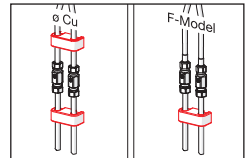
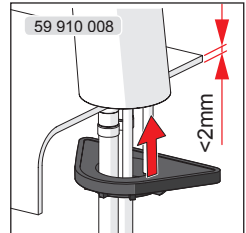
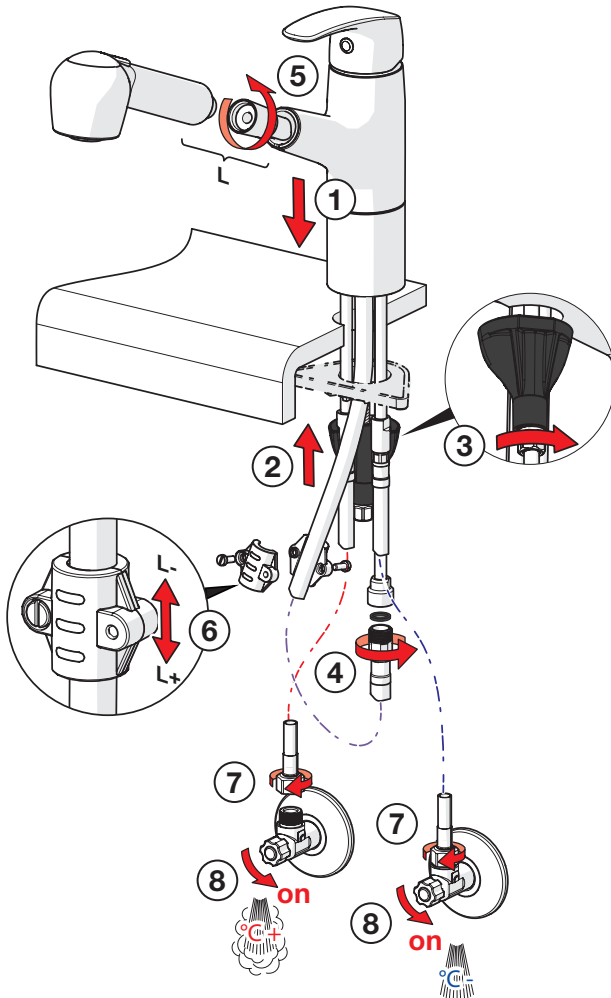

Installation

CZ Montáž

DE Montage

DK Installation

ES Montaje

FI Asennus

FR Installation

GR Συναρμολόγηση

HU Szerelés

IT Montaggio

NL Installatie

NO Montering

PL Instalacja

PT Instruções

RU Установка

SE Installation

SK Inštalácia

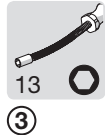
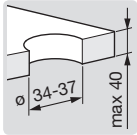

max.
1600 kPa

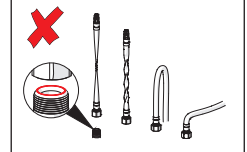
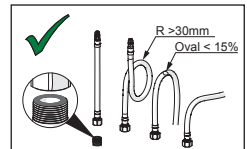
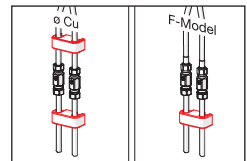
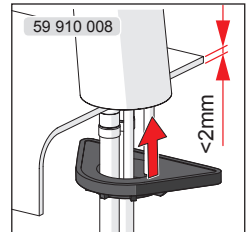
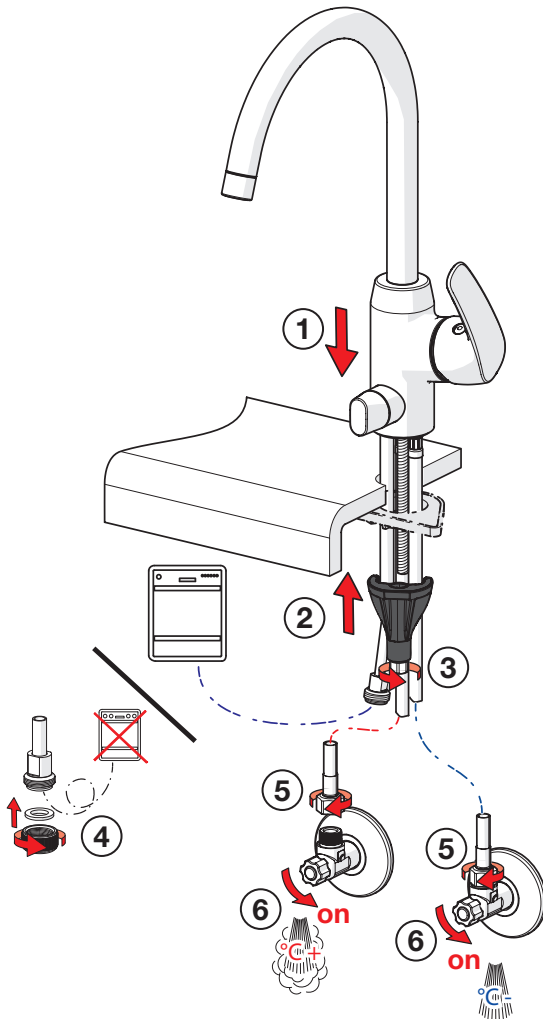

Operation

CZ Funkce
DE Funktion
DK Betjening
ES Servicio

FI Toiminta
FR Utilisation
GR Λειτουργία
HU Üzemeltetés

IT Funzionamento
NL Bediening
NO Funksjon
PL Działanie

PT Funcionamento
RU Принцип действия
SE Funktion
SK Prevádzka

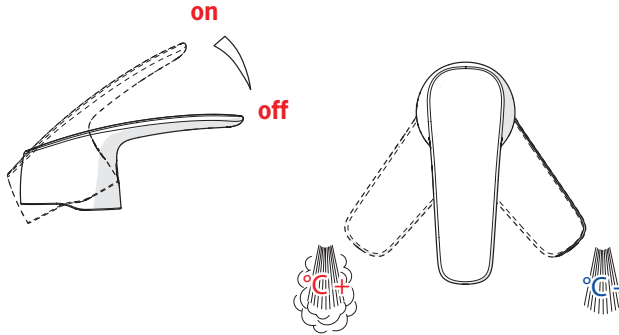

Limiting the flow rate

CZ Omezení průtoku
DE Bergenzung der Durchflußmenge
DK Begrænsning af vandmængden
ES Limitación de la tasa de flujo
FI Virtaaman rajoitus
FR Limitation du débit
GR Περιορισμός ρυθμού ροής
HU Az áramlás határolása

IT Limitazione della portata
NL Begrenzing van de doorstroomhoeveelheid
NO Begrensning av vannmengde
PL Ograniczenie wielkości strumienia
PT Limitar o caudal
RU Регулирование потока
SE Flödesbegränsning
SK Obmedzenie prietoku

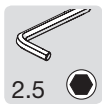

2.5

②

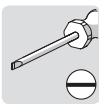

③

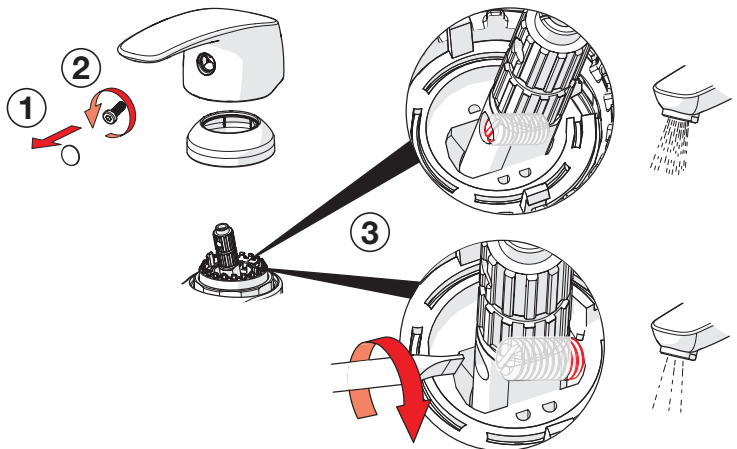

Changing for hot water

CZ Přestavení na horkou vodu

DE Umstellung auf Warmwasseranschluß

DK Omstilling til varmt vand

ES Cambio para agua caliente

FI Muuttaminen kuumalle vedelle

FR Valvole per lavastoviglie o lavatrici

GR Αλλαγή για ζεστό νερό

HU Átváltás meleg vízre

IT Per miscelatore per lavello

NL Chngement pour arrivée eau chaude

NO Omstilling til varmt vann

PL Zmiana na ciepłą wodę

PT Mudança para água quente

RU Перенастройка на подачу горячей вод

SE Omställning till varmt vatten

SK Prestavenie na teplú vodu

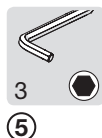
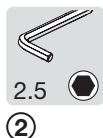
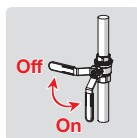

1

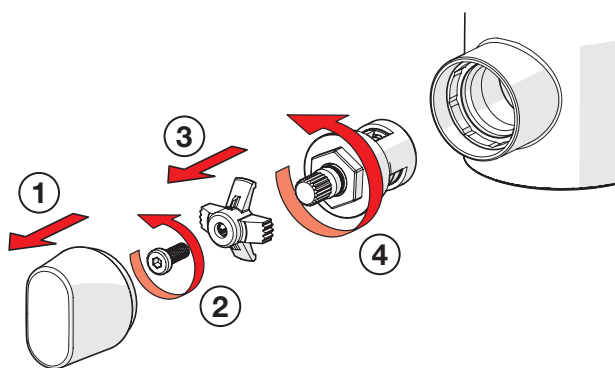

2

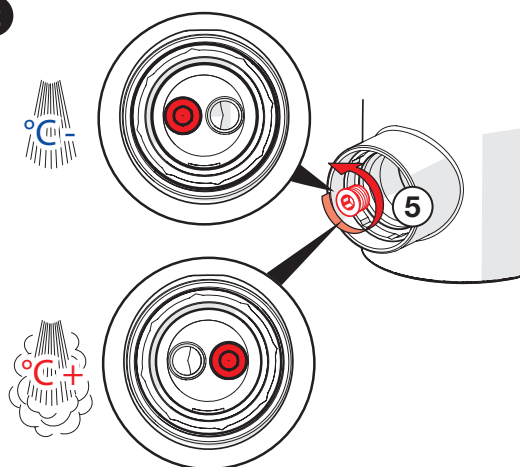

3

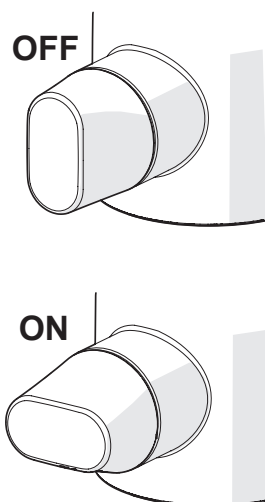

To change the cartridge

CZ Výměna kartuše

DE Auswechseln der Patrone

DK Udskiftning af reguleringskassette (unit)

ES Montaje del cartucho

FI Säätöosan vaihto

FR Montage et démontage de la cartouche

GR Αντικατάσταση του στοιχείου

HU A patron cseréje

IT Montaggio della cartuccia

NL Vervangen van het keramische binnenwerk

NO Skifting av kassett

PL Wymiana modułu sterującego

PT Substituição do cartucho

RU Замена регулировочного блока

SE Byte av kassett

SK Výměna kartuše

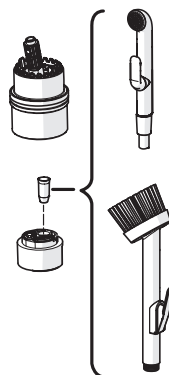
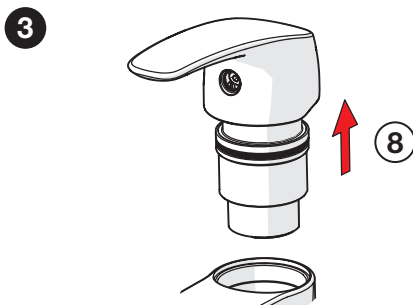
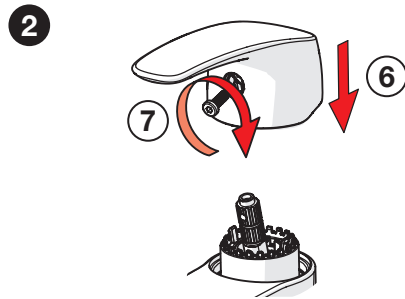
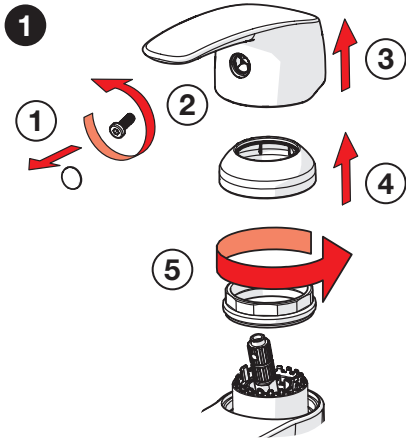
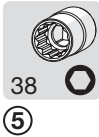
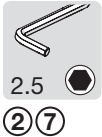
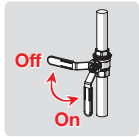

To change the spout's swing angle

CZ Výміна výtokového ramene

DE Den Schwenkbereich des Auslaufs ändern

DK Ændring af tudens svingradius

ES Variación del radio d'azione della bocca

FI Juoksutputken kääntymiskulman muuttaminen

FR Changement de la rotation du bec

GR Για αλλαγή της γωνίας στροφής του χείλους εκροής

HU A kifolyó hajlásszögének módosítása

IT Per modificare l'angolo di rotazione della bocca

NL Om de draaihoek van de uitloop te wijzigen

NO Begrensning av tudens svingutslag

PL W celu zmiany kąta obrotu wylewki

PT Para mudar o ângulo de rotação do bico

RU Изменение угла поворота излива

SE Ändring av utloppsrörens svängradie

SK Možnosť zmeny veľkosti úhlu otáčení výtokového ramene

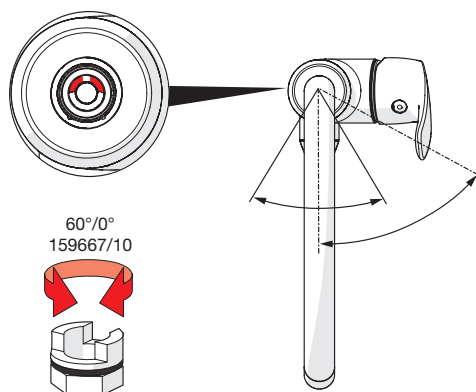
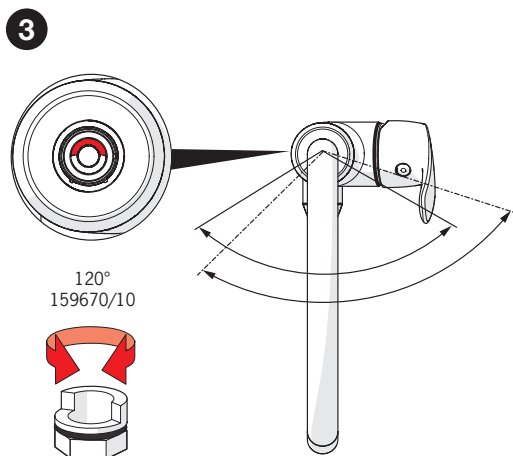
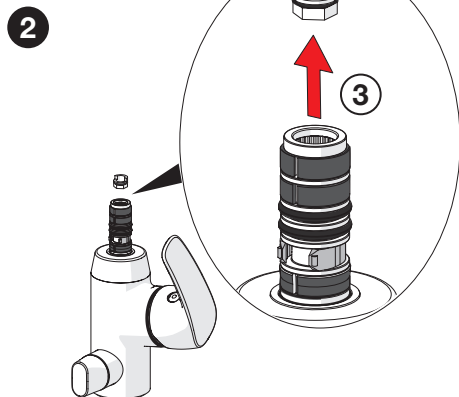
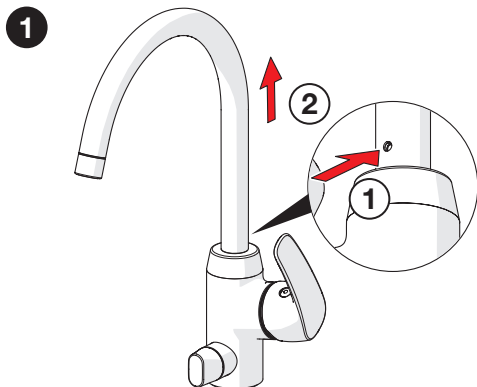
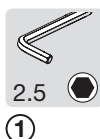

Cleaning the faucet

CZ Čištění baterie

DE Reinigung der Armatur

DK Rengøring af armaturet

ES Limpieza de la grifería

FI Puhdistus

FR Nettoyage du robinet

GR Καθαρισμός του βρύση

HU Takarítás a csapot

IT Pulizia della rubinetteria

NL Reinigen van de kraan

NO Rengjøring av kranen

PL Czystczenie baterii

PT Limpeza da torneira

RU Чистка смесителя

SE Rengöring av blandarna

SK Čistenie vodovodnej batérie

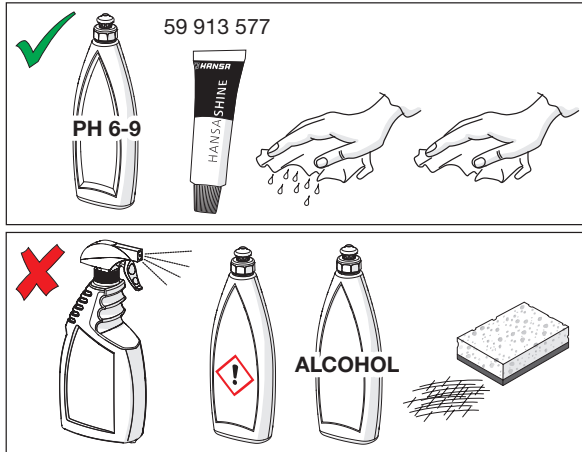

Cleaning/Changing the aerator

CZ Čištění/Výměna perlátoru

DE Reinigung/Wechseln des Luftsprudlers

DK Rensning/Udskiftning af perlator

ES Limpieza/Cambiar el aireador

FI Poresuuttimen puhdistaminen/vaihtaminen

FR Nettoyage/Changement de l'aérateur

GR Καθαρισμός/αλλαγή αεριστήρα

HU Az aerátor tisztítása/cseréje

IT Pulizia/Sostituzione dell'aeratore

NL Reinigen/veranderen van de perlator

NO Rensning/Bytting av strålesamler

PL Czystczenie/Wymiana perlatora

PT Limpar/substituir o arejador

RU Очистка и замена аэратора

SE Rengöring/Byte av strålsamlare

SK Čistenie/Výmena perlátora

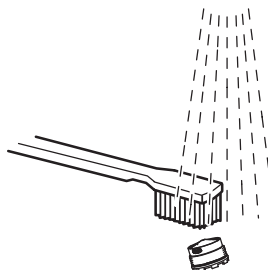

Spare parts

CZ Náhradní díly

FI Varaosat

NL Reserve-onderdelen

RU Запасные части

DE Ersatzteile

FR Pièces détachées

NO Reservedeler

SE Reservdelar

DK Reservedele

HU Alkatrészek

PL Części zamienne

SK Náhradné diely

ES Piezas de recambio

IT Pezzi di ricambio

PT Peças de reposição

4508 2283, 4538 1183, 4508 2283 0037

1	59 914 453	
2	59 914 482	
3	59 914 128	
4	59 914 129	
4	59 914 500	(4538 1183)
5	59 914 499	
6	59 914 489	
7	59 914 474	
8	59 914 475	
9	59 914 501	(4508 2283)
9	59 902 692	(4538 1183)
9	59 914 461	(4508 2283 0037)
10	59 914 490	
11	59 914 485	
12	59 914 486	
13	59 914 491	
14	59 910 008	

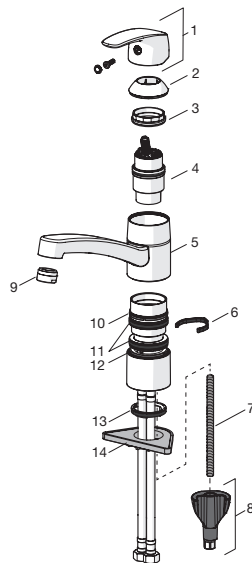

4520 2283

1	59 914 453
2	59 914 482
3	59 914 128
4	59 914 129
5	59 914 499
6	59 914 489
7	59 914 474
8	59 914 475
9	59 914 501
10	59 914 490
11	59 914 485
12	59 914 486
13	59 914 433
14	59 914 434
15	59 914 491
16	59 910 008

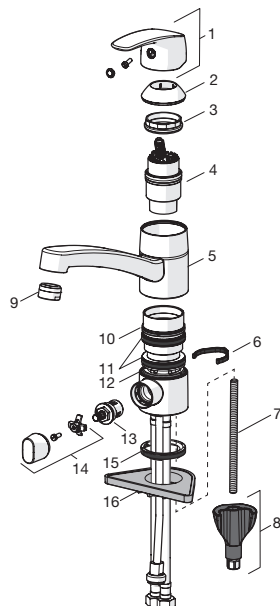

Spare parts

CZ Náhradní díly	FI Varaosat	NL Reserve-onderdelen	RU Запасные части
DE Ersatzteile	FR Pièces détachées	NO Reservedeler	SE Reservdelar
DK Reservedele	HU Alkatrészek	PL Części zamienne	SK Náhradné diely
ES Piezas de recambio	IT Pezzi di ricambio	PT Peças de reposição	

4518 2283

- 1 59 914 453
- 2 59 914 482
- 3 59 914 128
- 4 59 914 129
- 5 59 914 496
- 6 59 914 345
- 7 59 914 497
- 8 59 910 008
- 9 59 914 474
- 10 59 914 475

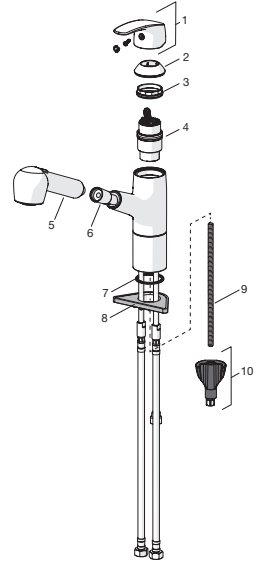

4513 2283, 4513 2283 0037

- 1 59 914 436
- 2 59 914 498
- 3 59 914 429 (120°)
- 3 59 914 264 (60°/0°)
- 4 59 914 266
- 5 59 914 129
- 6 59 914 128
- 7 59 914 454
- 8 59 914 453
- 9 59 913 653
- 10 59 910 008
- 11 59 914 474
- 12 59 914 475

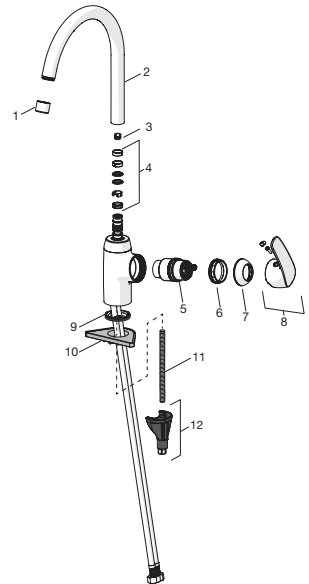

Spare parts

CZ Náhradní díly	FI Varaosat	NL Reserve-onderdelen	RU Запасные части
DE Ersatzteile	FR Pièces détachées	NO Reservedeler	SE Reservdelar
DK Reservedele	HU Alkatrészek	PL Części zamienne	SK Náhradné diely
ES Piezas de recambio	IT Pezzi di ricambio	PT Peças de reposição	

4514 2283

- 1** 59 914 436
- 2** 59 914 498
- 3** 59 914 429 (120°)
- 3** 59 914 264 (60°/0°)
- 4** 59 914 266
- 5** 59 914 129
- 6** 59 914 128
- 7** 59 914 454
- 8** 59 914 453
- 9** 59 914 433
- 10** 59 914 434
- 11** 59 913 653
- 12** 59 910 008
- 13** 59 914 474
- 14** 59 914 475

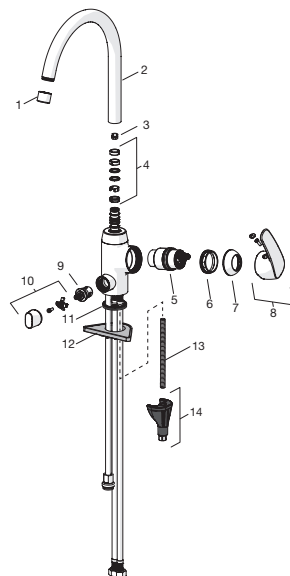

Oras Group is a powerful European provider of sanitary fittings: the market leader in the Nordics and a leading company in Continental Europe. The company's mission is to make the use of water easy and sustainable and its vision is to become the European leader of advanced sanitary fittings. Oras Group has two strong brands, Oras and Hansa.

The head office of the Group is located in Rauma, Finland, and the Group has four manufacturing sites: Burglengenfeld (Germany), Kralovice (Czech Republic), Olesno (Poland) and Rauma (Finland). Oras Group employs approximately 1400 people in twenty countries. Oras Group is owned by Oras Invest, a family company and an industrial owner.

HANSA Armaturen GmbH
P. O. BOX 81 02 40
D-70519 Stuttgart

Sigmaringer Strasse 107
D-70567 Stuttgart
Tel.: +49 711 16 14 0
Fax: +49 711 16 14 368
info@hansa.de

www.hansa.com



a member of orasgroup