

CE CE
EN14428 EN12150

- GB All shower products are designed and manufactured according to EN14428
All the glass used on the product are certified and tested according to EN12150
- ES Todas las mamparas han sido diseñadas y fabricadas de acuerdo con
Todos los cristales utilizados en nuestros productos están certificados y probados de acuerdo con

GME
DIVISIÓN BAÑOS

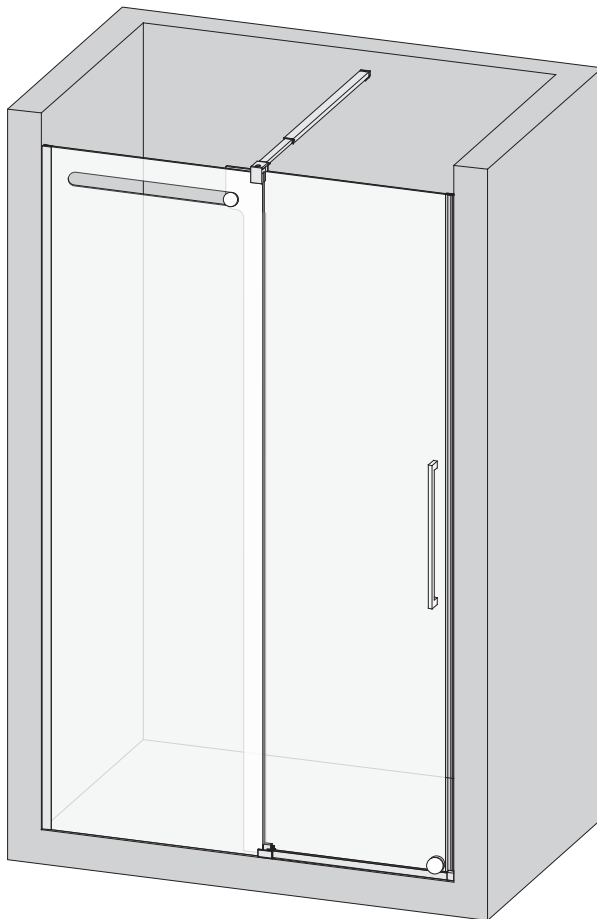

frontales
VETRUM
fijo & corredera

IMPORTANT INFORMATION/INFORMACIÓN IMPORTANTE

- Always wear safety goggles and work gloves when installing or disassembling this product, especially when working with glass panels.
 - When handling, never rest the corner of the glass directly on the floor or hit the corner with any object. This can cause the glass to break.
 - Always have two persons to install or disassemble the shower.
 - Small children should never use the shower unsupervised or without proper instructions for safety use.
 - Small children should never hit, lean, or hang on the shower product. Nor should they do any inappropriate activity in the vicinity of the shower.
 - Tempered safety glass is designed to shatter into small tiny pieces when the glass is broken, this is to avoid serious injury.
- ES**
- Llevar gafas y guantes de seguridad durante la instalación o desmontaje de este producto, especialmente durante la manipulación de los cristales
 - Durante la manipulación, nunca dejar descansar las esquinas de los cristales directamente en el suelo o golpearlos con cualquier objeto. Puede provocar la rotura del cristal
 - Es conveniente que la instalación o el desmontaje sea llevado a cabo por dos personas.
 - Los niños no deben usar la ducha sin supervisión o sin apropiadas instrucciones de uso para sus seguridad
 - Los niños no deben, bajo ningún concepto, golpear, apoyarse o colgarse de los productos de ducha. De la misma manera, deberán realizar actividades inapropiadas en las inmediaciones de la mampara.
 - El cristal templado de seguridad ha sido diseñado para romper en pequeñas piezas con el objetivo de evitar daños mayores

MAINTENANCE & CLEANING/MANTENIMIENTO Y LIMPIEZA

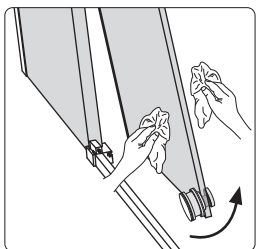
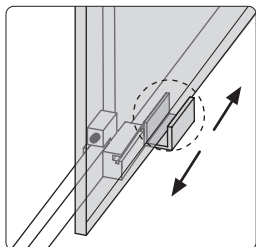

- GB**
- Rinse with clean water and dry with a soft cotton cloth or sponge. Do not use anything abrasive such as a scouring brush or sponge to clean the surfaces.
 - For tough stains, use a gentle liquid detergent such as dish soap and hot water. Do not use an abrasive and acidic cleaner.
 - Always try the cleaning solution on a less visible surface before applying it to the rest.
 - Completely rinse with water immediately after applying the cleaner.
 - Regular cleaning prevents the accumulation of dirt and tough stains.
- ES**
- Enjuagar con agua limpia y secar con una ballesta o esponja. No usar ningún tipo de material abrasivo que pueda dañar la superficie del material.
 - Para eliminar manchas difíciles, use detergente líquido como lavavajillas y agua caliente. No usar limpiadores abrasivos o componentes ácidos.
 - Probar los productos de limpieza nuevos en una superficie lo menos visible posible antes de su aplicación en todo el producto
 - Enjuagar con agua inmediatamente después de aplicar el producto de limpieza.
 - La limpieza regular previene la acumulación de suciedad y manchas

** Tips/Consejos:

- GB** The way to dismantle the sliding guide set, as shown in the image.
- ES** La imagen muestra como desmontar el guiador inferior para limpieza de cristales.

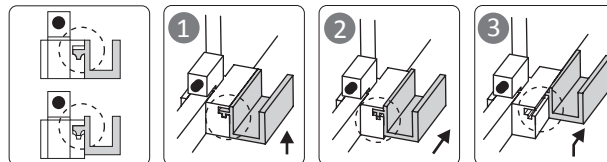

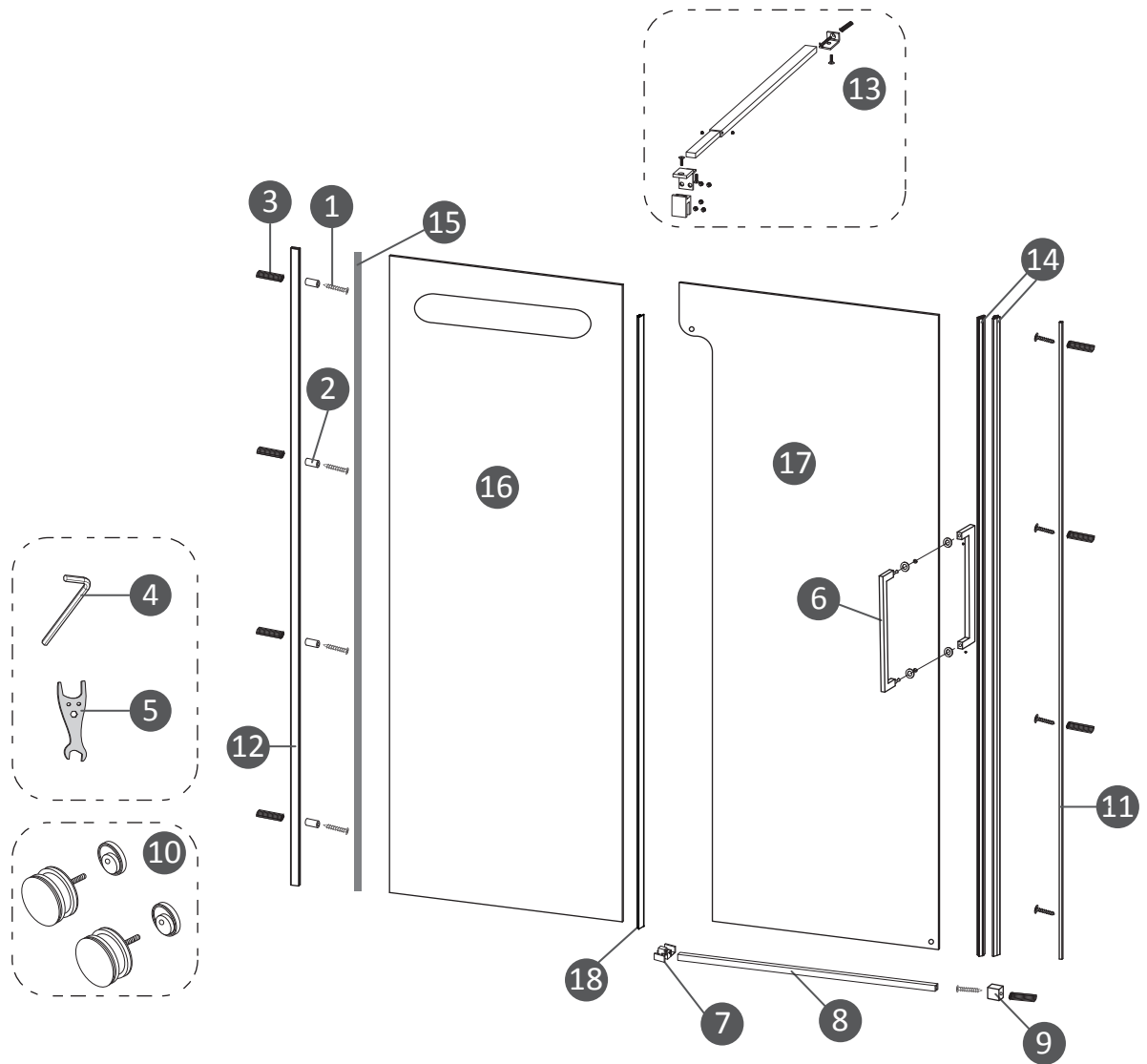

#	Description/Descripción
01	ST4x45mm screw set
02	Internal plastic plugs
03	Plastic plugs
04	Allen key
05	Spanner
06	Handle set
07	Sliding guide set(A)
08	Sill extrusion
09	Sliding guide set(B)
10	Idler wheel
11	Wall jamb extrusion of mobile panel
12	Wall jamb fix panel
13	Pull rod
14	PVC water deflector bottom gasket
15	PVC seal gasket for fix panel
16	Fixed panel
17	Mobile panel
18	Goma cristal puerta corredera central

NECESSARY TOOLS/HERRAMIENTAS NECESARIAS

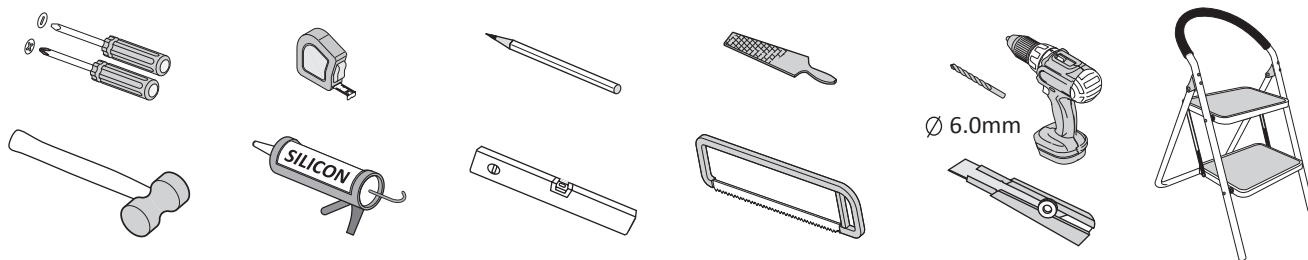

DIMENSIONS/MEDIDAS

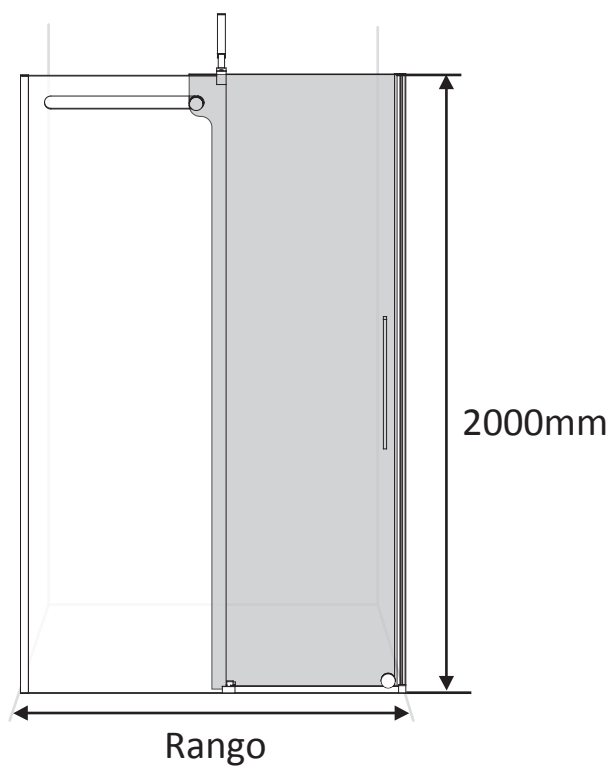
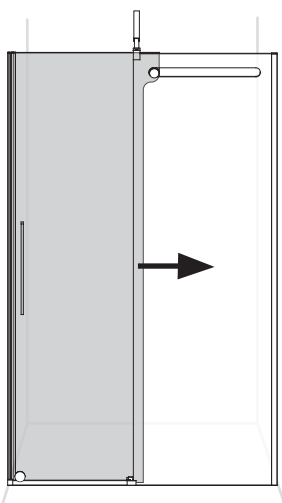
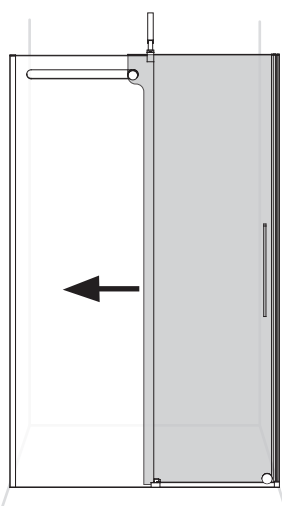

Reference/Referencias	Description/Descripción	Opening Range/Apertura	Range/Rango
1050	frontal ducha VETRUM 120	40,7-45,7	117-122
1051	frontal ducha VETRUM 125	40,7-45,7	122-127
1052	frontal ducha VETRUM 130	45,7-50,7	127-132
1053	frontal ducha VETRUM 135	45,7-50,7	132-137
1054	frontal ducha VETRUM 140	50,7-55,7	137-142
1055	frontal ducha VETRUM 145	50,7-55,7	142-147
1056	frontal ducha VETRUM 150	55,7-60,7	147-152
1057	frontal ducha VETRUM 155	55,7-60,7	152-157
1058	frontal ducha VETRUM 160	60,7-65,7	157-162
1059	frontal ducha VETRUM 165	60,7-65,7	162-167
1060	frontal ducha VETRUM 170	65,7-70,7	167-172
1061	frontal ducha VETRUM 175	60,7-65,7	172-177
1062	frontal ducha VETRUM 180	65,7-70,7	177-182

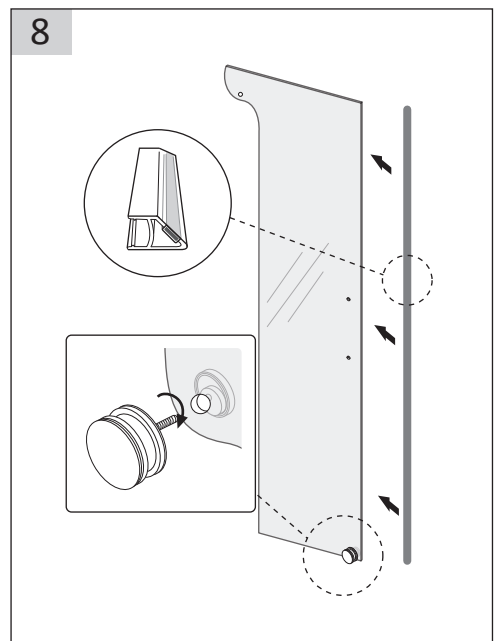
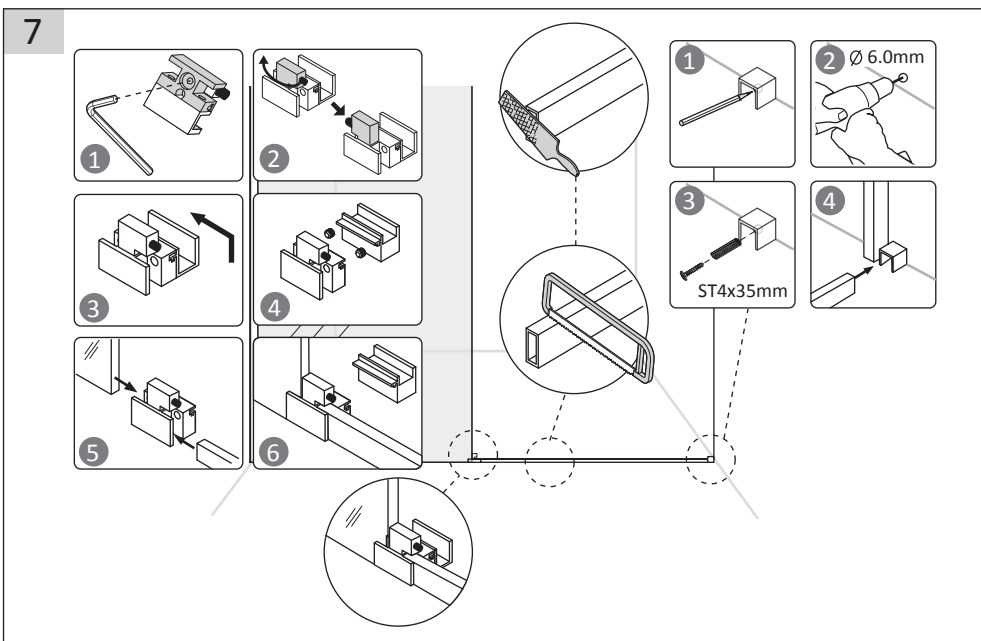
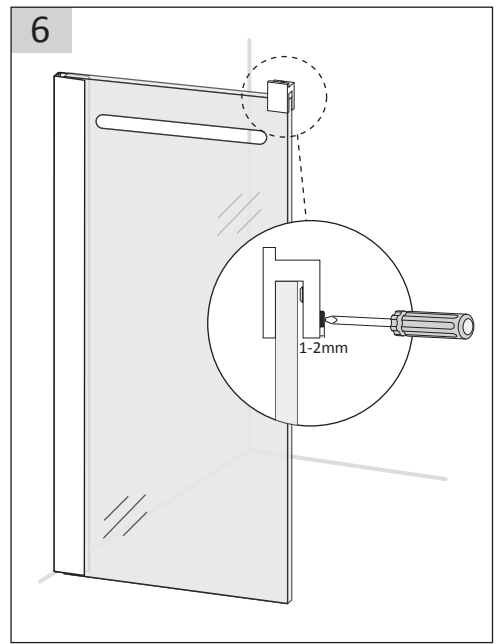
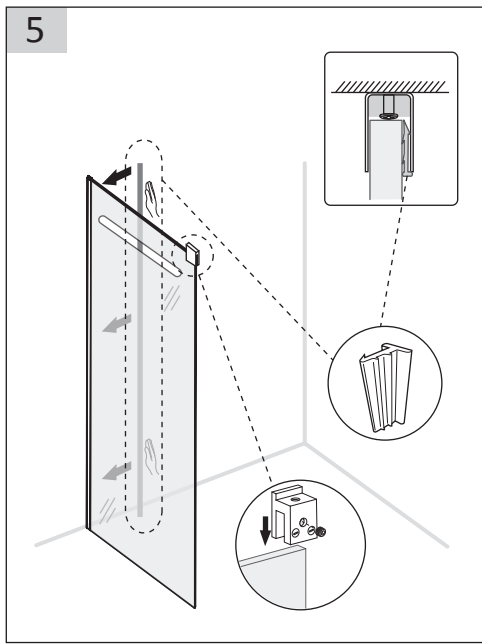
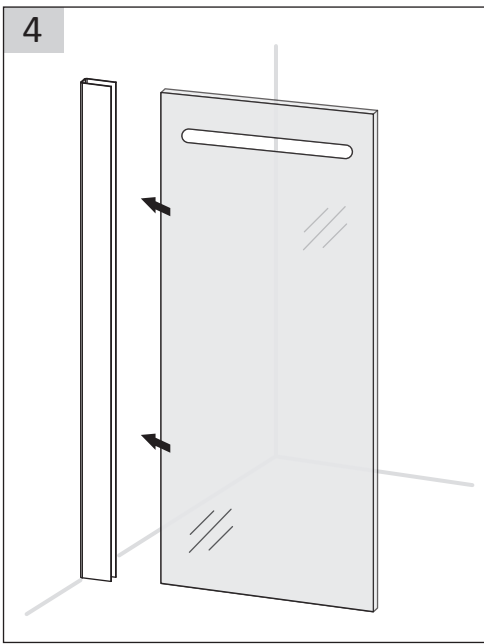
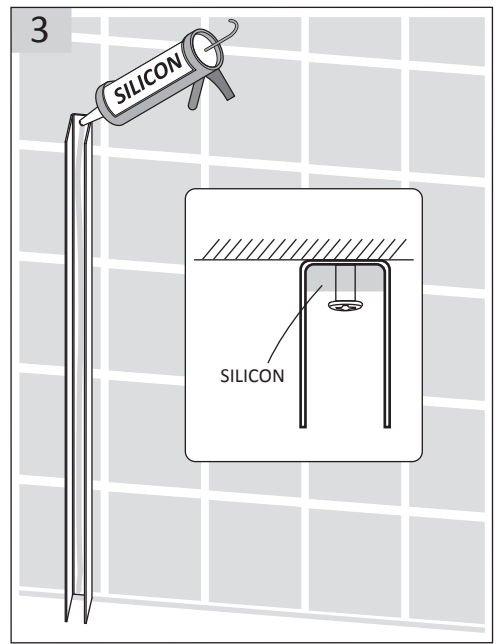
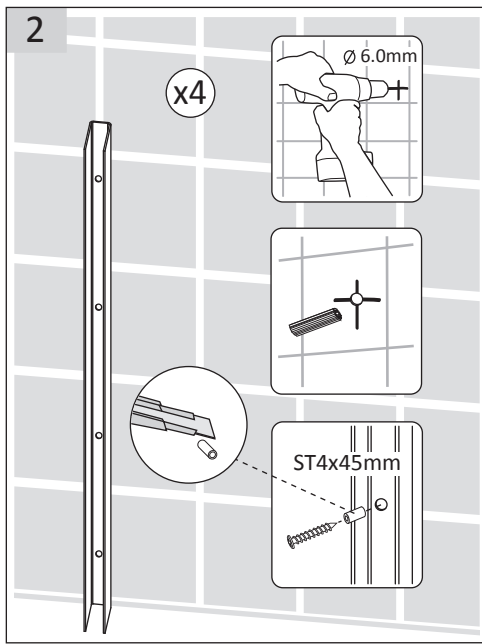
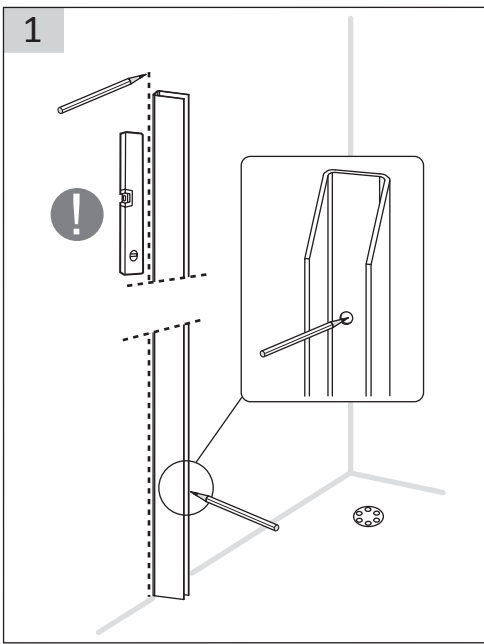

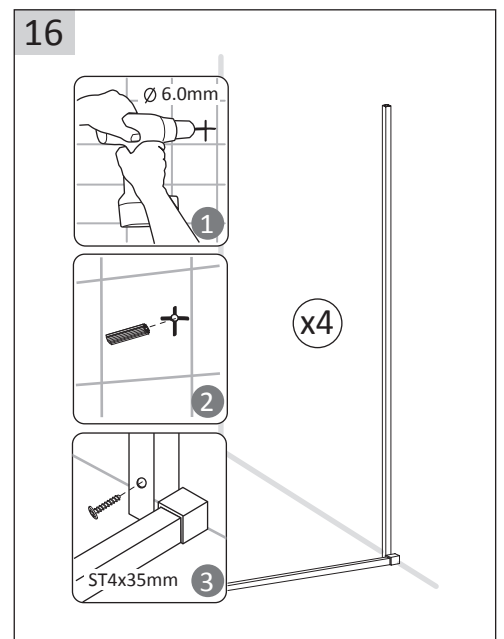
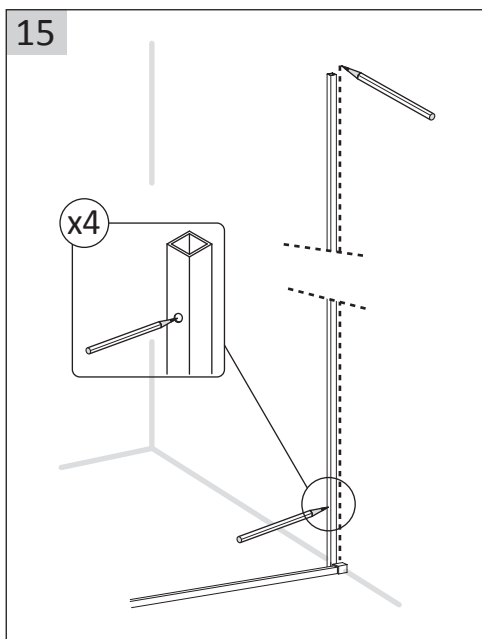
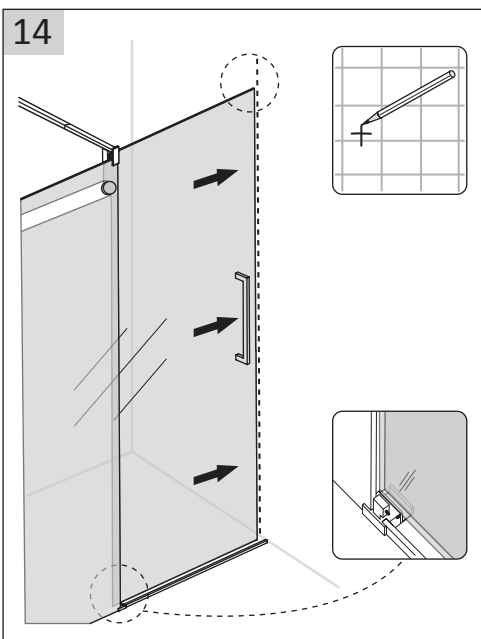
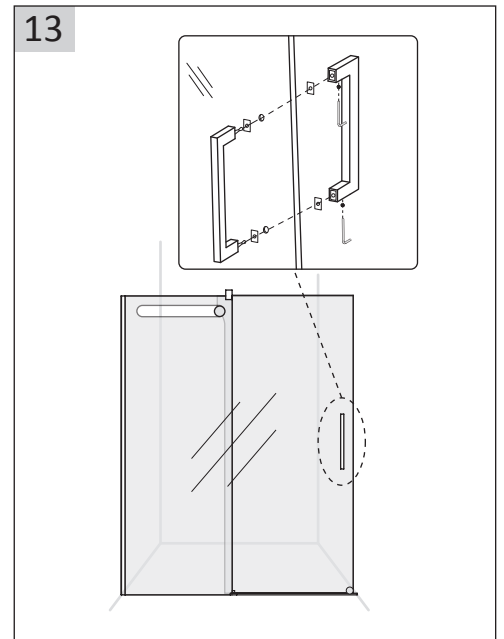
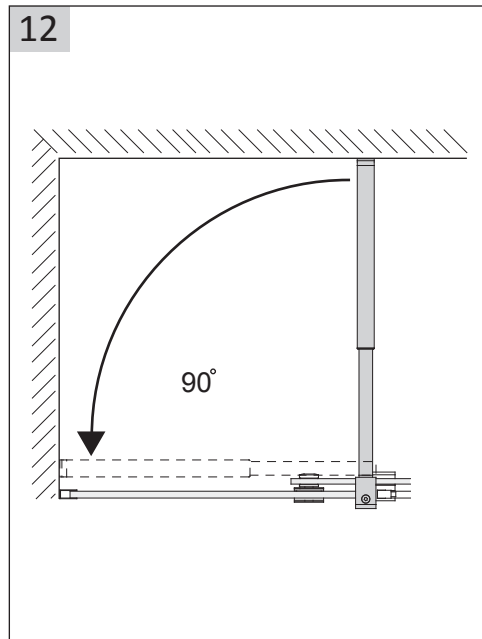
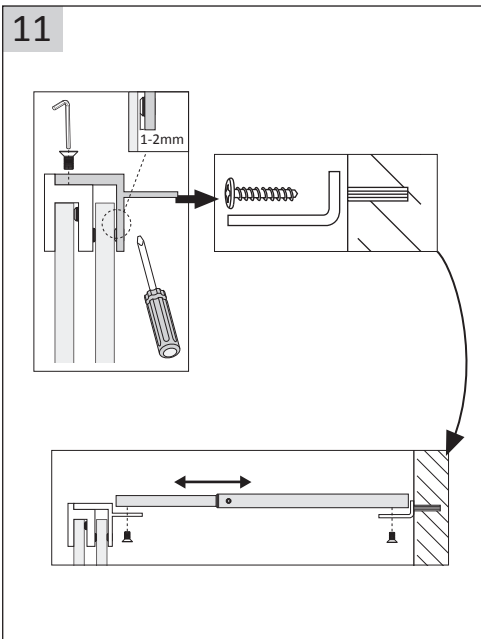
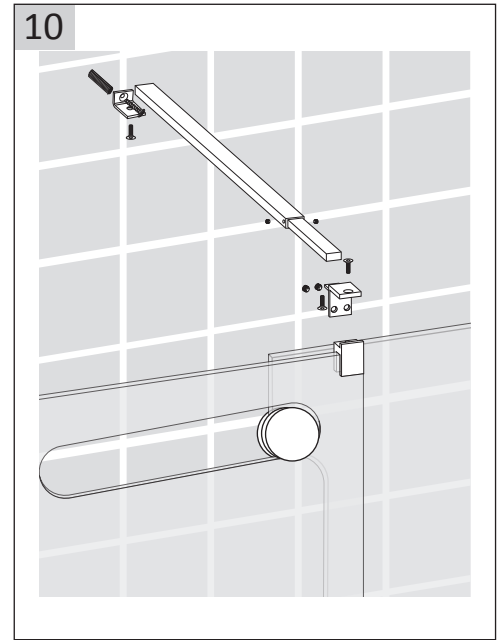
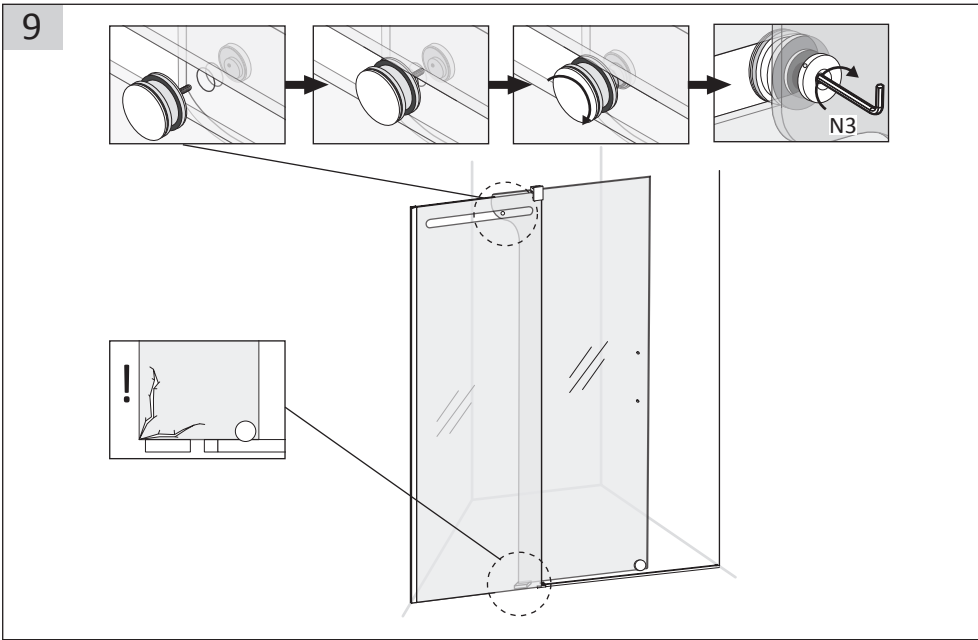

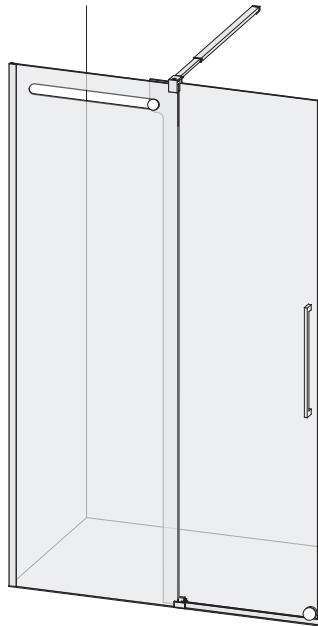
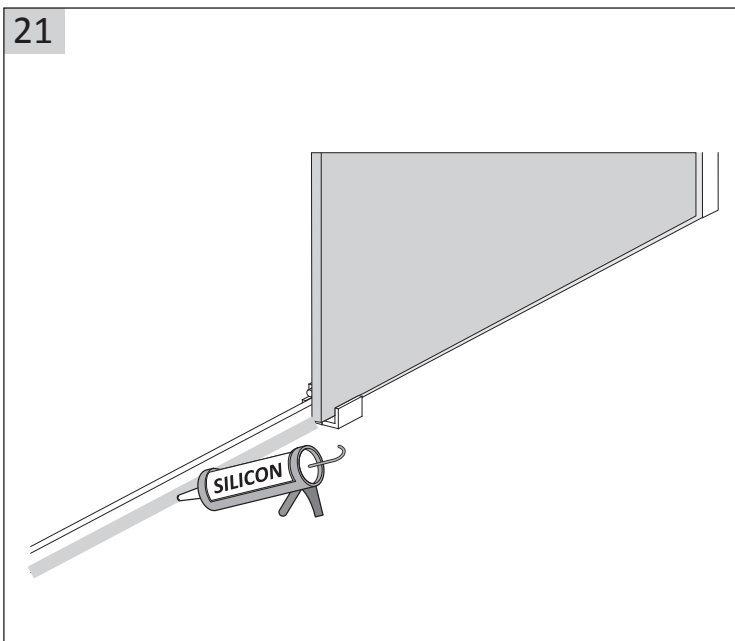
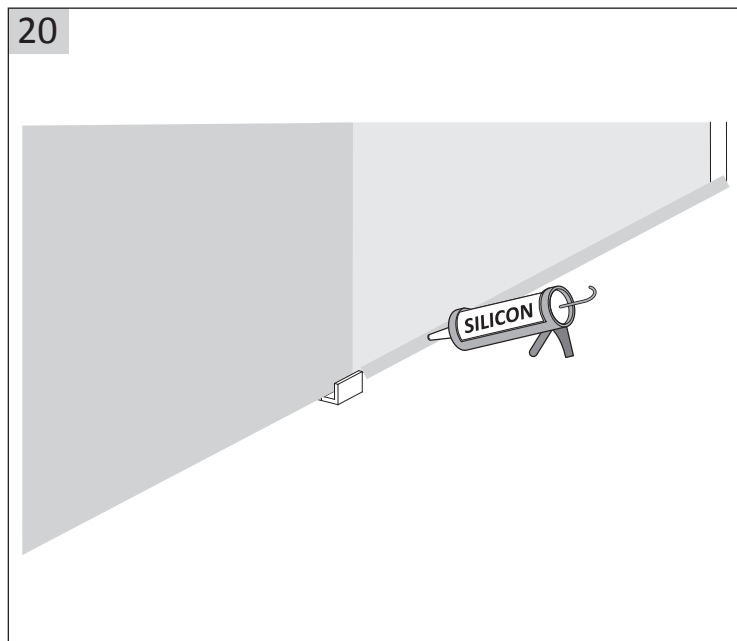
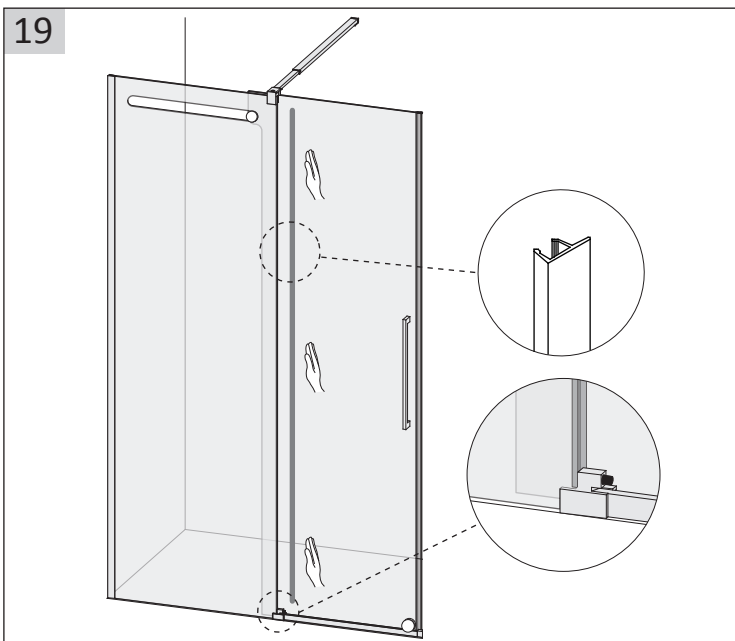
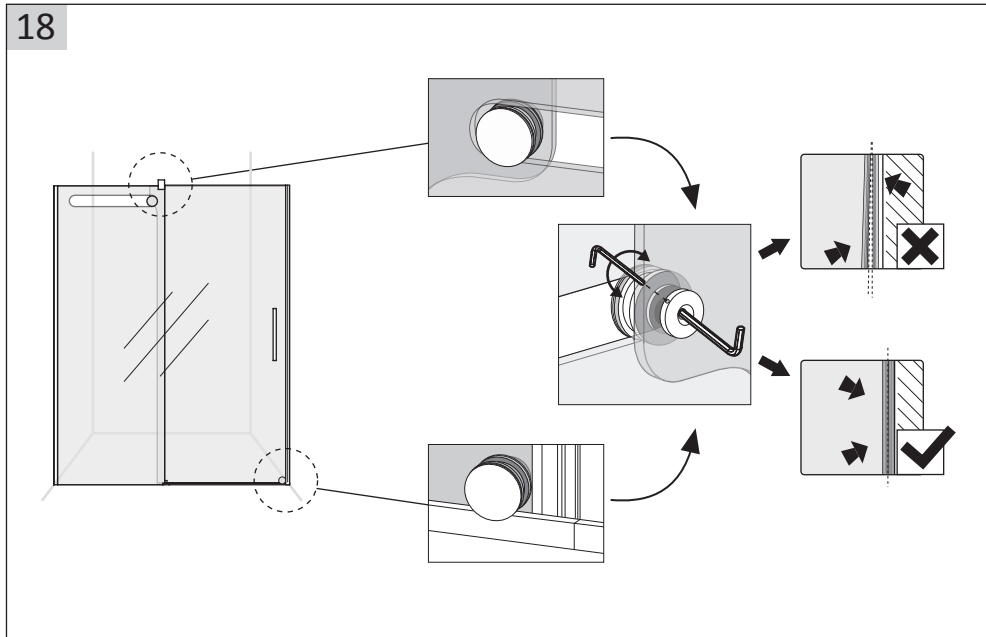
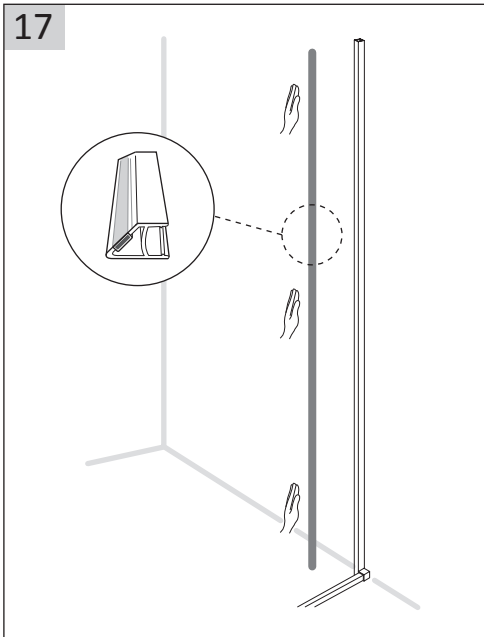

GME Lorente Internacional SL
C\ Pinaeta,6
Pq. Ciudad Mudeco
46930 - Quart Poblet
(Valencia) -España

telf. 00 34 96 252 18 55
fax 00 34 96 252 18 56
info@gmelorente.com
www.gmelorente.com

GME
DIVISIÓN BAÑOS