

70345

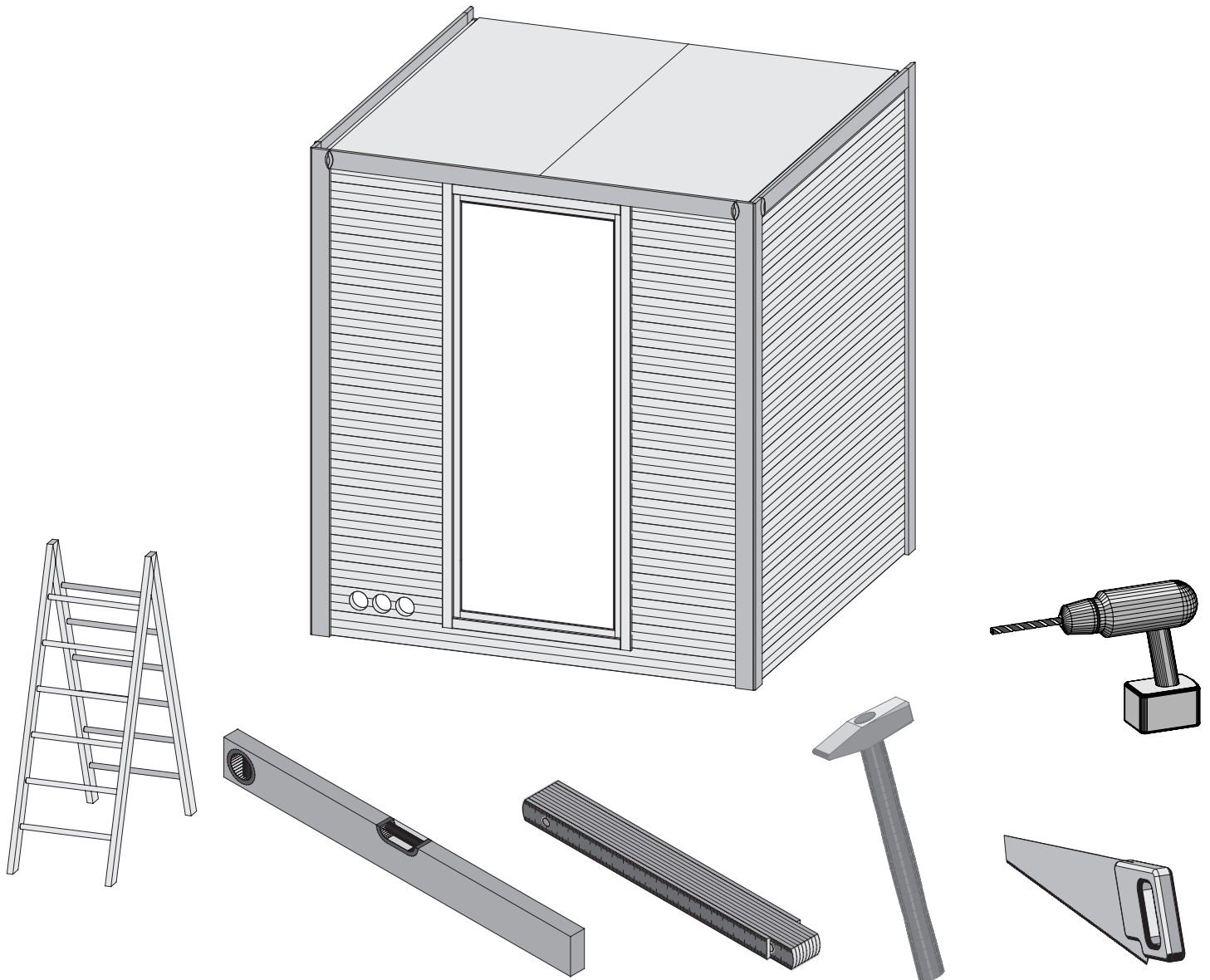

 **Aufbauanleitung**

 **notice de montage**

 **Building Instructions**

 **montagehandleiding**

 **Instrucciones de construcción**

 **Istruzioni per il montaggio**

 **Service-Hotline: +49 421 38693 33**



Vergleichen Sie zuerst die Materialliste mit Ihrem Paketinhalt! Bitte haben Sie Verständnis, dass Beanstandungen nur im nicht aufgebauten Zustand bearbeitet werden können!



Commencez par comparer la liste du matériel avec le contenu de votre paquet! Sachez que nous traitons uniquement les réclamations concernant le matériel à l'état non monté!



First compare the list of materials with your package contents! Please understand that complaints can be processed in the non-built status only!



Vergelijk eerst de lijst van materialen met de inhoud van uw pakket! Reclamaties kunnen alleen in behandeling worden genomen zolang de onderdelen nog niet zijn gemonteerd!



En primer lugar, compare la lista de material con el contenido del paquete. Rogamos entienda que las reclamaciones sólo pueden ser tramitadas antes de montar el objeto!



Confrontate questa distinta materiali prima con il contenuto del pacchetto! Vi preghiamo di comprendere che eventuali reclami possono essere accolti solo prima del montaggio!



70345

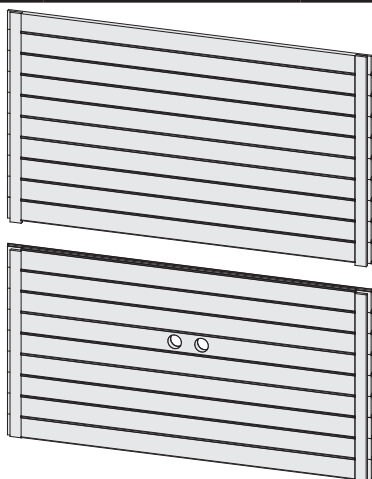

1 x W1 | 2040 x 1888 x 40mm | ID 20712



1 x W4 | 1930 x 576 x 40mm | ID 20714

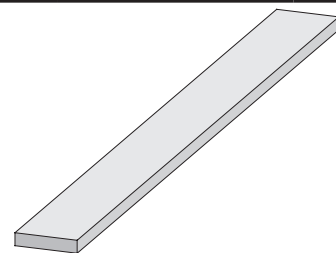

1 x B1	1920 x 20 x 3mm	ID 20799
3 x B2	1800 x 78 x 17mm	ID 48524
2 x B3	800 x 45 x 18mm	ID 24796
1 x B4	300 x 95 x 18mm	ID 19130
4 x B5	480 x 95 x 18mm	ID 20930
4 x B6	565 x 95 x 18mm	ID 15498
4 x B7	60 x 38 x 28mm	ID 20928
3 x B8	575 x 38 x 28mm	ID 21788
2 x B9	1120 x 38 x 28mm	ID 26146
2 x B10	1731 x 38 x 28mm	ID 20698
2 x B11	1756 x 38 x 28mm	ID 20699
2 x B12	800 x 58 x 28mm	ID 41003



2 x W2 | 2040 x 1770 x 40mm | ID 20719



1 x W5 | 1930 x 532 x 40mm | ID 20715

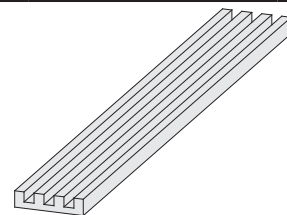

1 x E1 | 1850 x 110 x 26mm | ID 26480

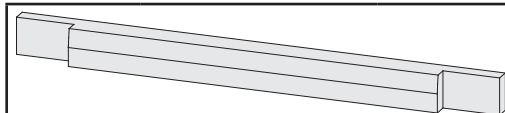

1 x E2 | 935 x 121 x 47mm | ID 58578

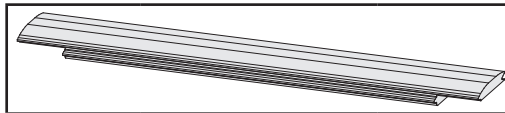

1 x E3 | 1888 x 121 x 38mm | ID 42376



1 x W3

- Siehe Türpaket
- Opmerking Door Package
- Note Door Package
- Remarque Package porte
- Nota Paquete Puerta
- Nota Door Package
- Poznámka Door balíček

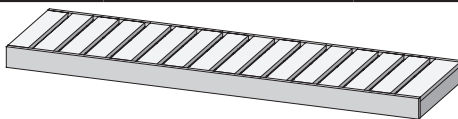

1 x L1 | 1177 x 500 x 90mm | ID 52065

2 x L2 | 1810 x 550 x 90mm | ID 43994

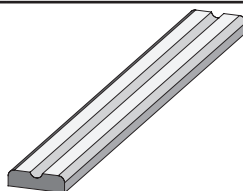

1 x L3 | 1177 x 90 x 22mm | ID 26156

1 x L4 | 1310 x 90 x 22mm | ID 26389

1 x L5 | 1810 x 90 x 22mm | ID 26112

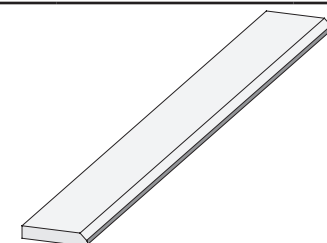

6 x G1 | 2085 x 78 x 18mm | ID 48525

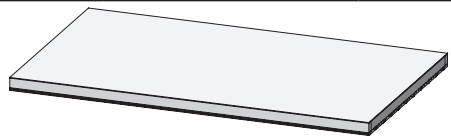

2 x M1 | 1727 x 904 x 57mm | ID 43858

1 x

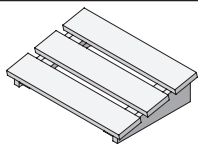

ID 20708



60 x	4 x 35mm	ID 3687
100 x	4 x 50mm	ID 3688
25 x	4 x 70mm	ID 3689
35 x	6 x 60mm	ID 14014



50 x | 4,5 x 40mm | ID 26285

6 x S1



ID 14266



50 x S2	4,5 x 30mm	ID 26116
6 x S3	12 x 18mm	ID 46403

3 x S4

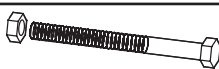

ID 14018

6 x T1



ID 26118

10m

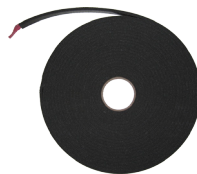

ID 14025

1 x



ID 64231

2 x

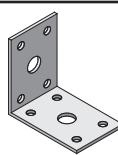

ID 20803

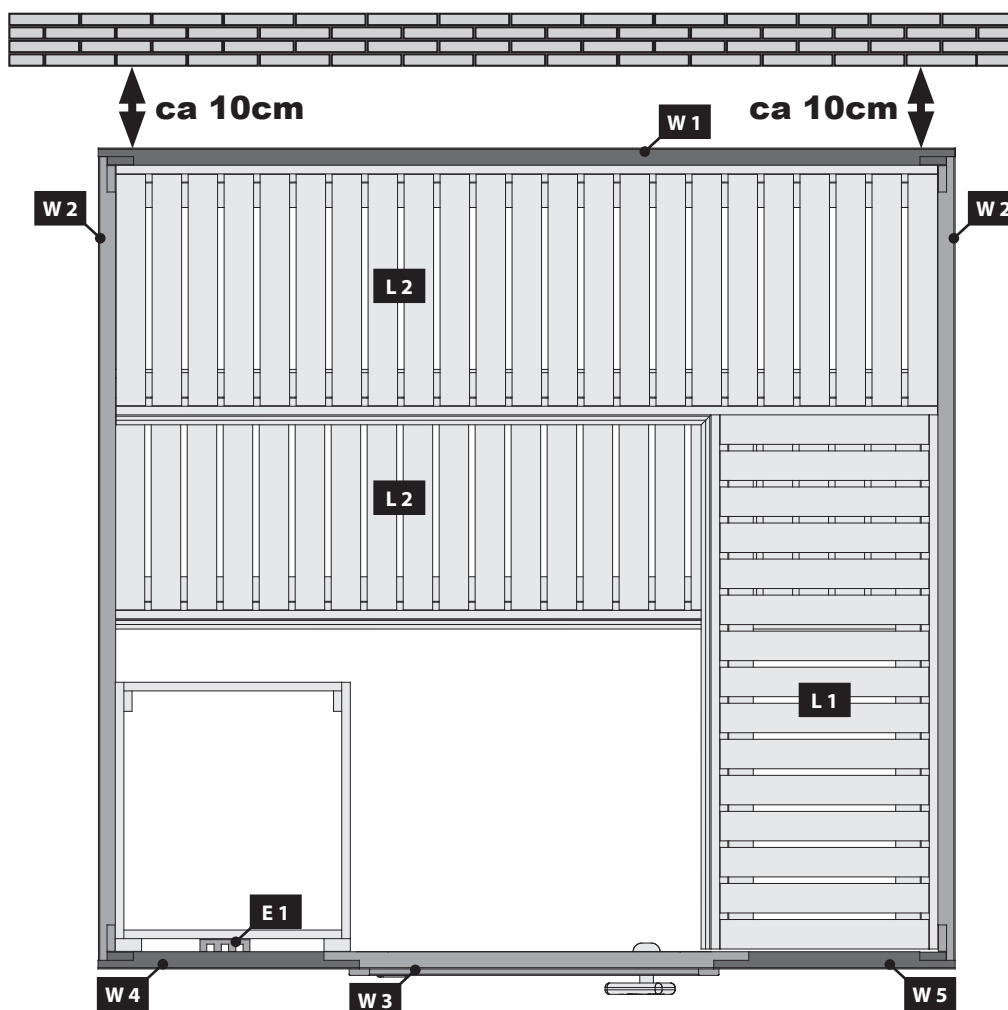

02

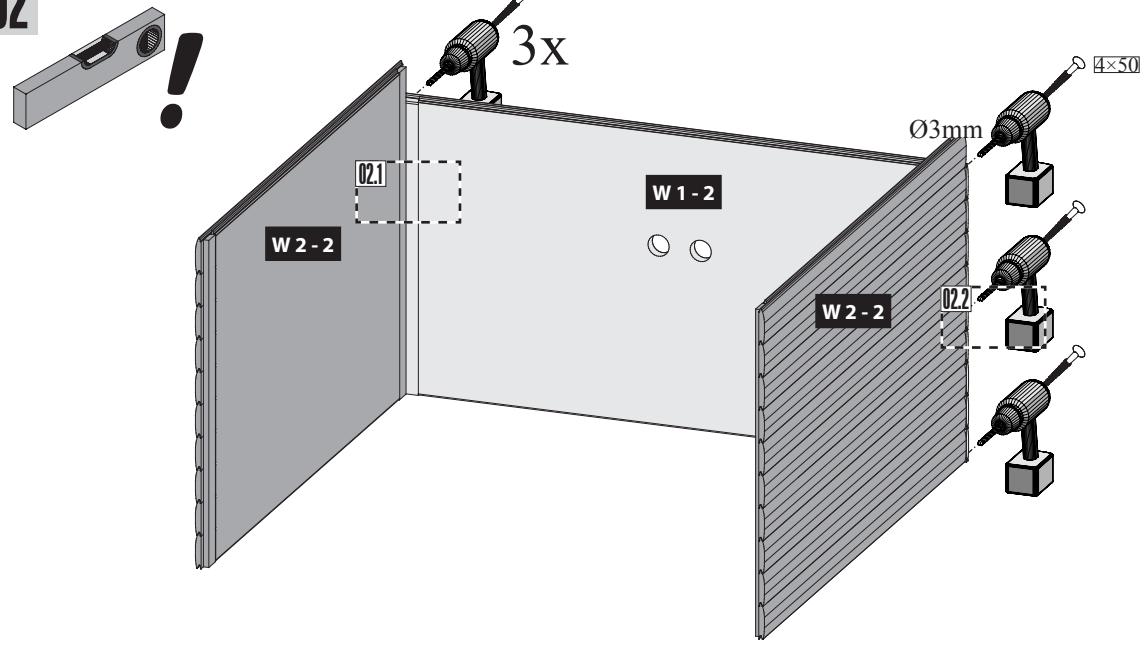

02.1

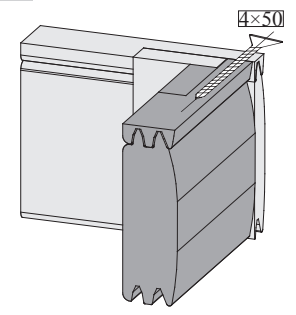

02.2

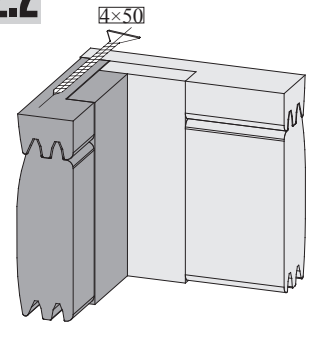

03

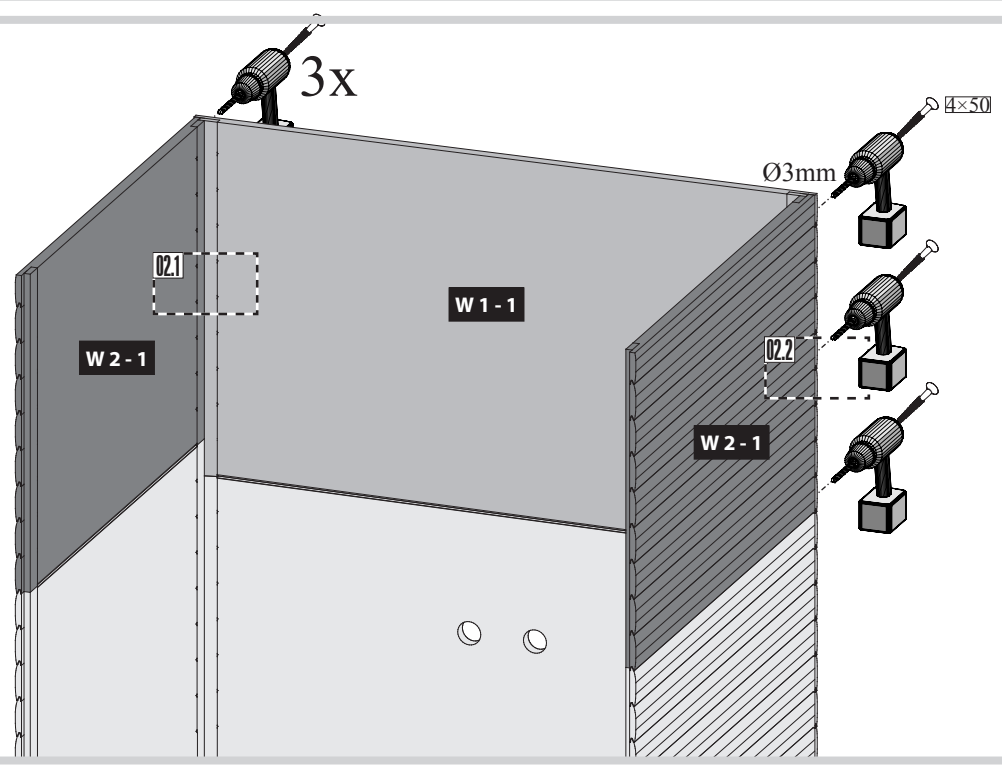

04

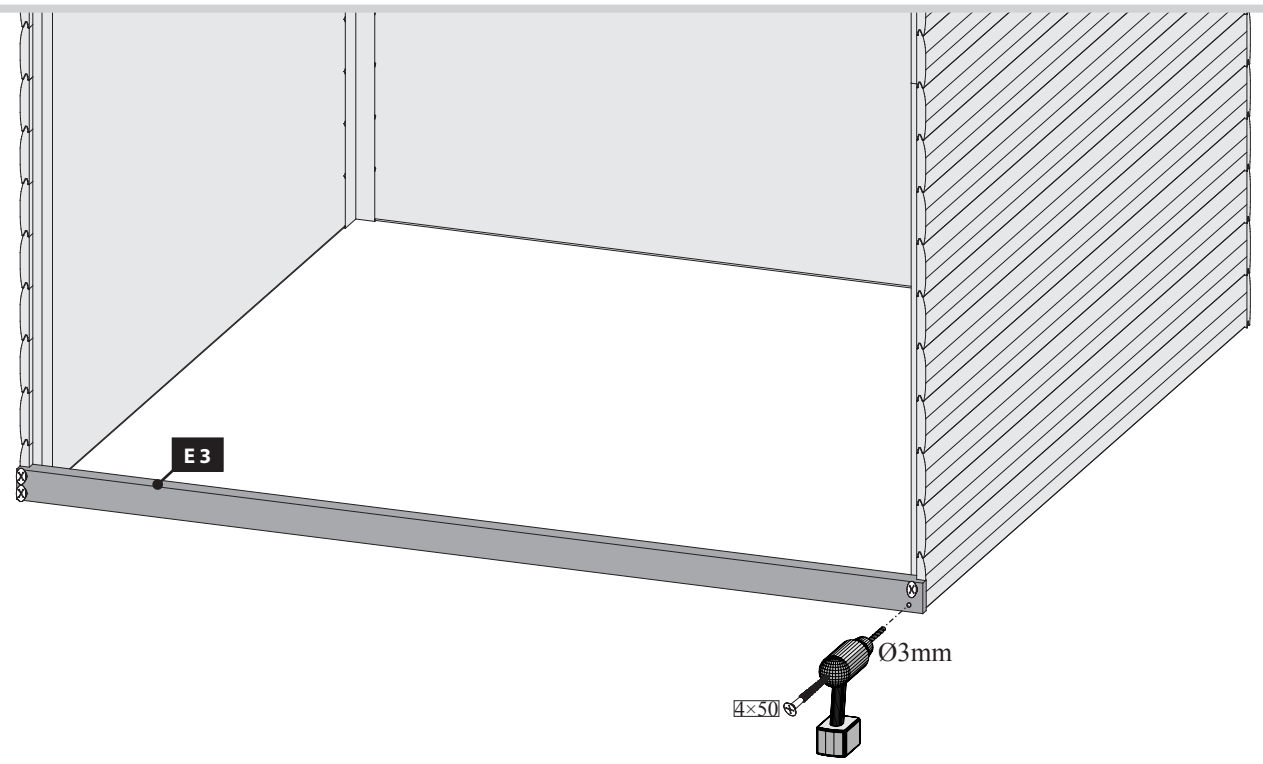

05

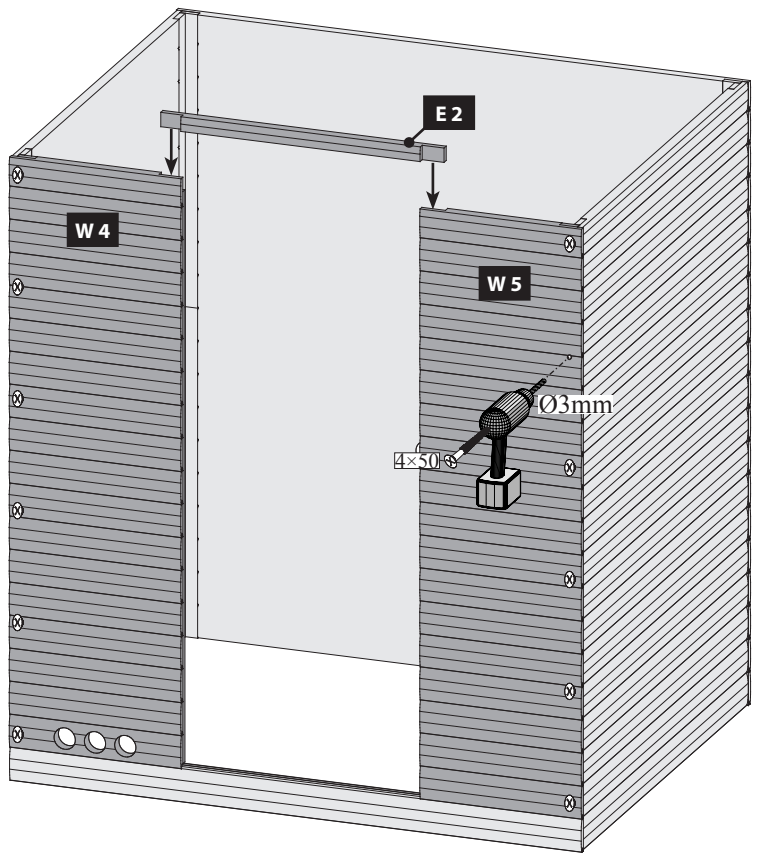

06

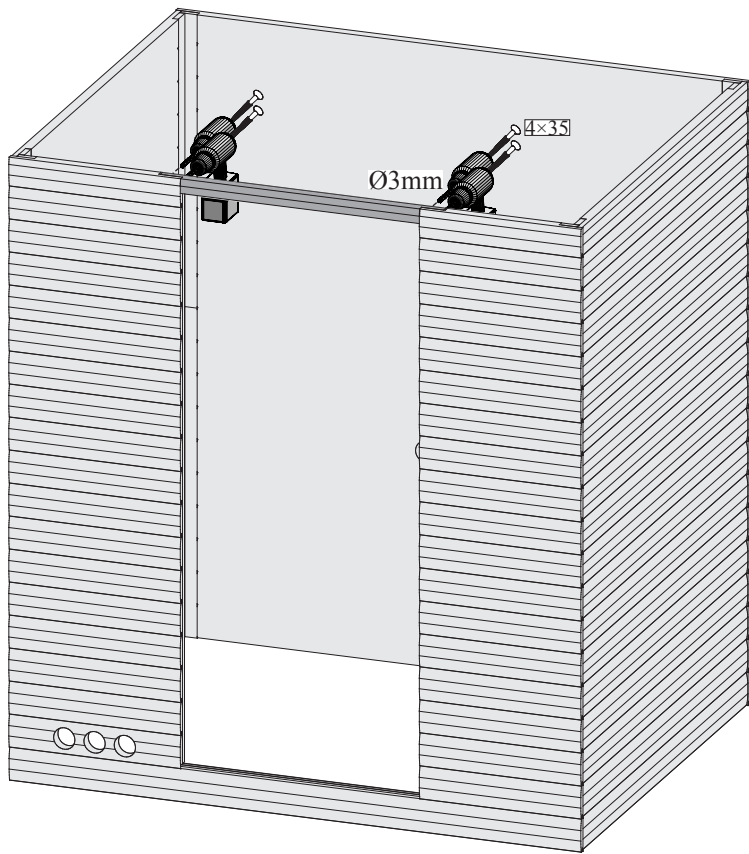

07

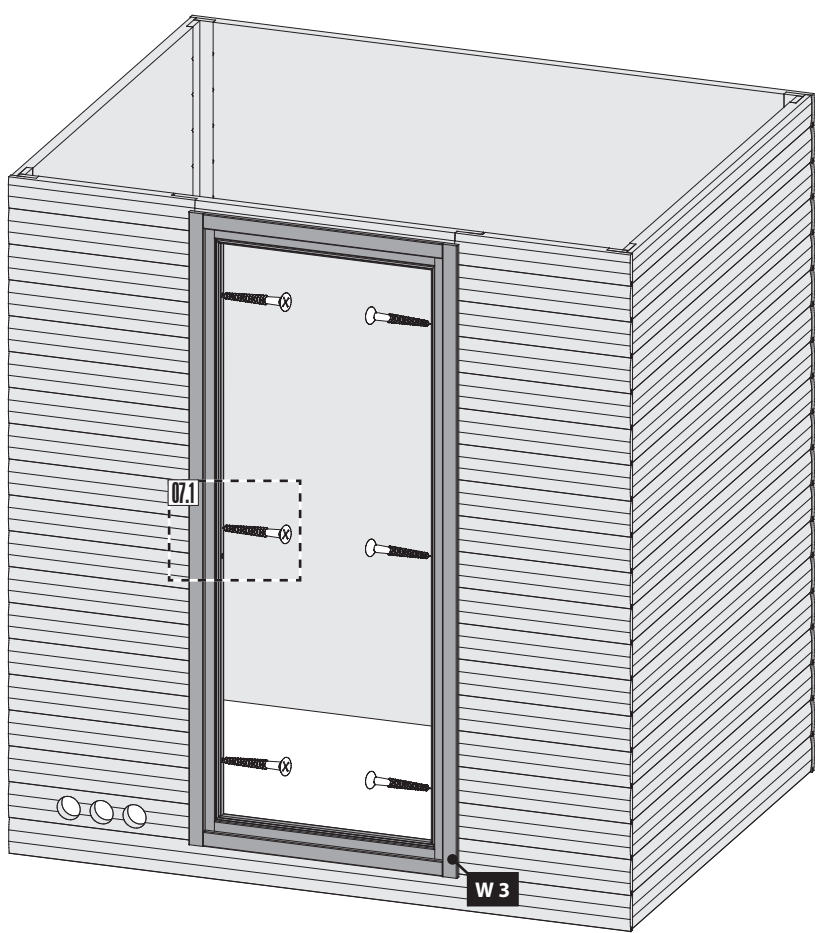

07.1-1

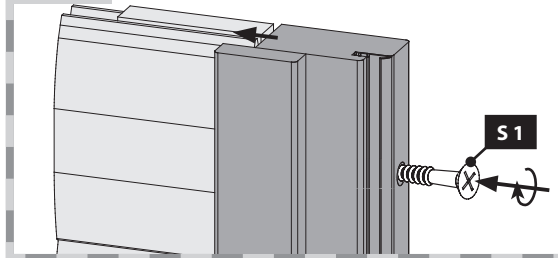

07.1-2

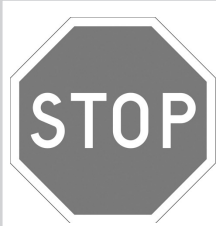
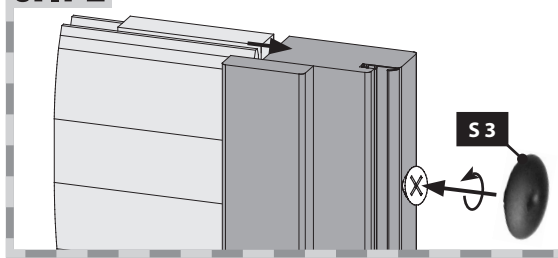

-  Einbau Saunatür
-  Installation de porte Sauna
-  Sauna door installation
-  Sauna deur installatie
-  Instalación de la puerta Sauna
-  Installazione porta Sauna
-  Sauna Instalace dveře

!!! 01 → 03 **!!!**

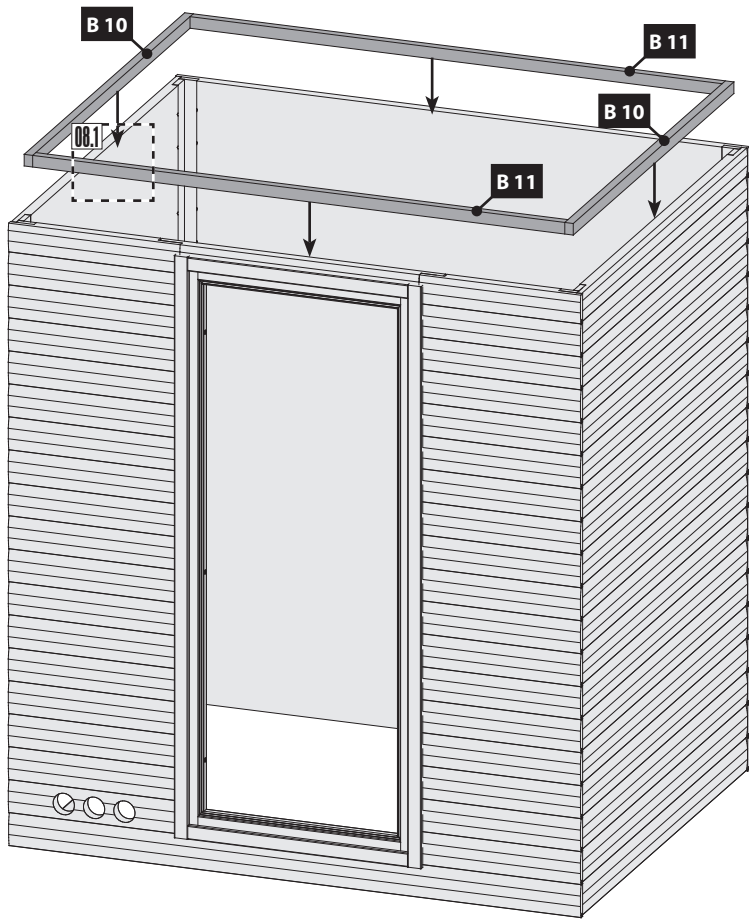
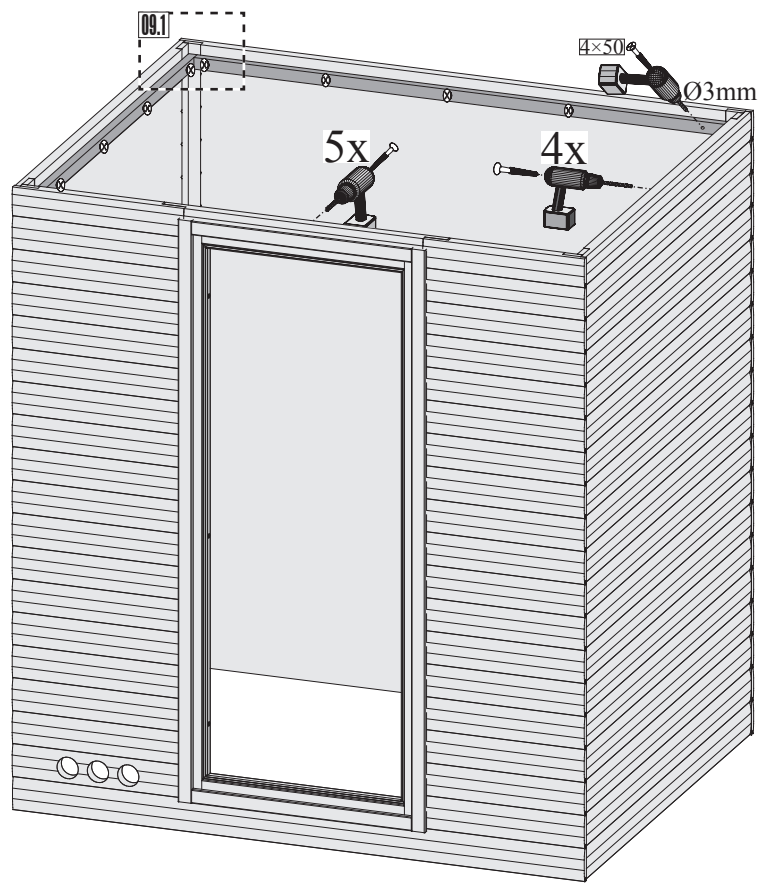
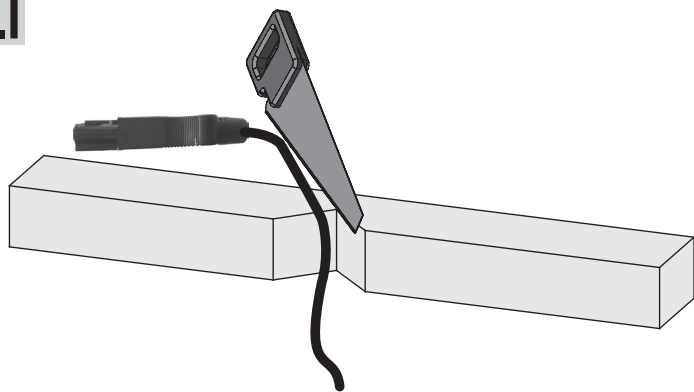
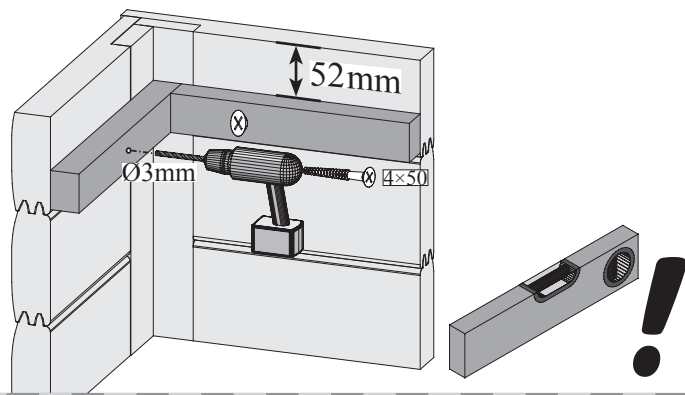
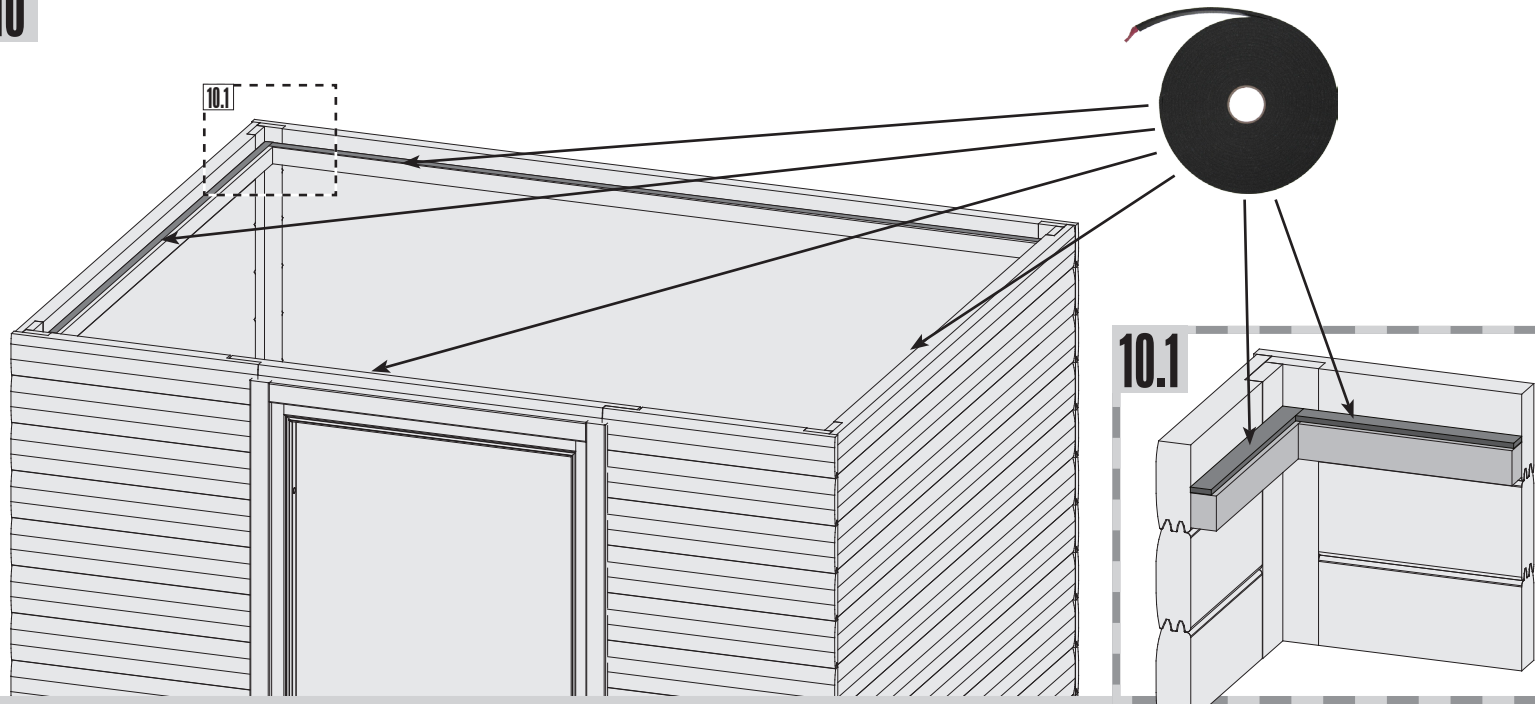
08**09****08.1****09.1****10**

11

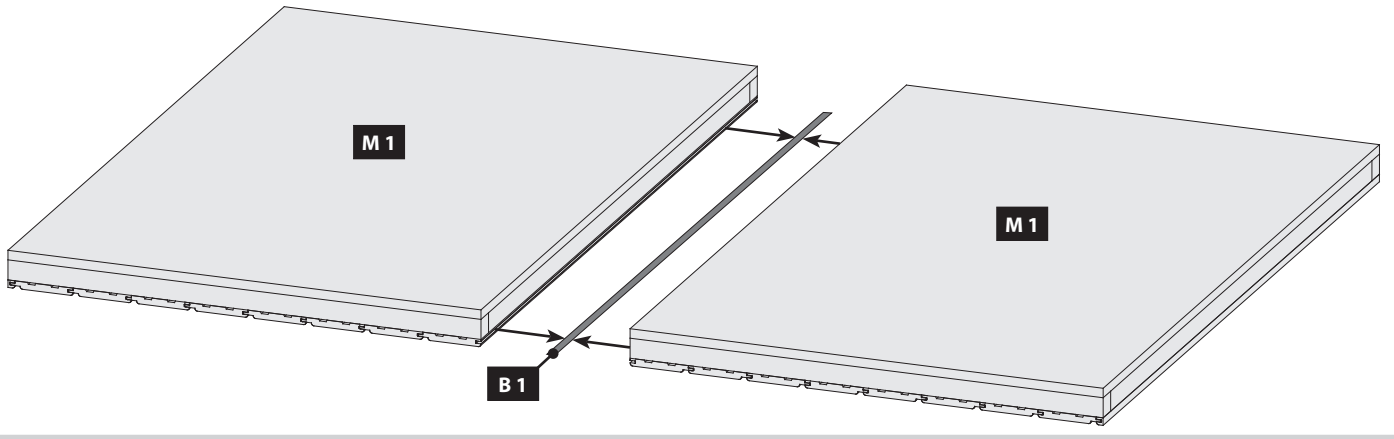

12

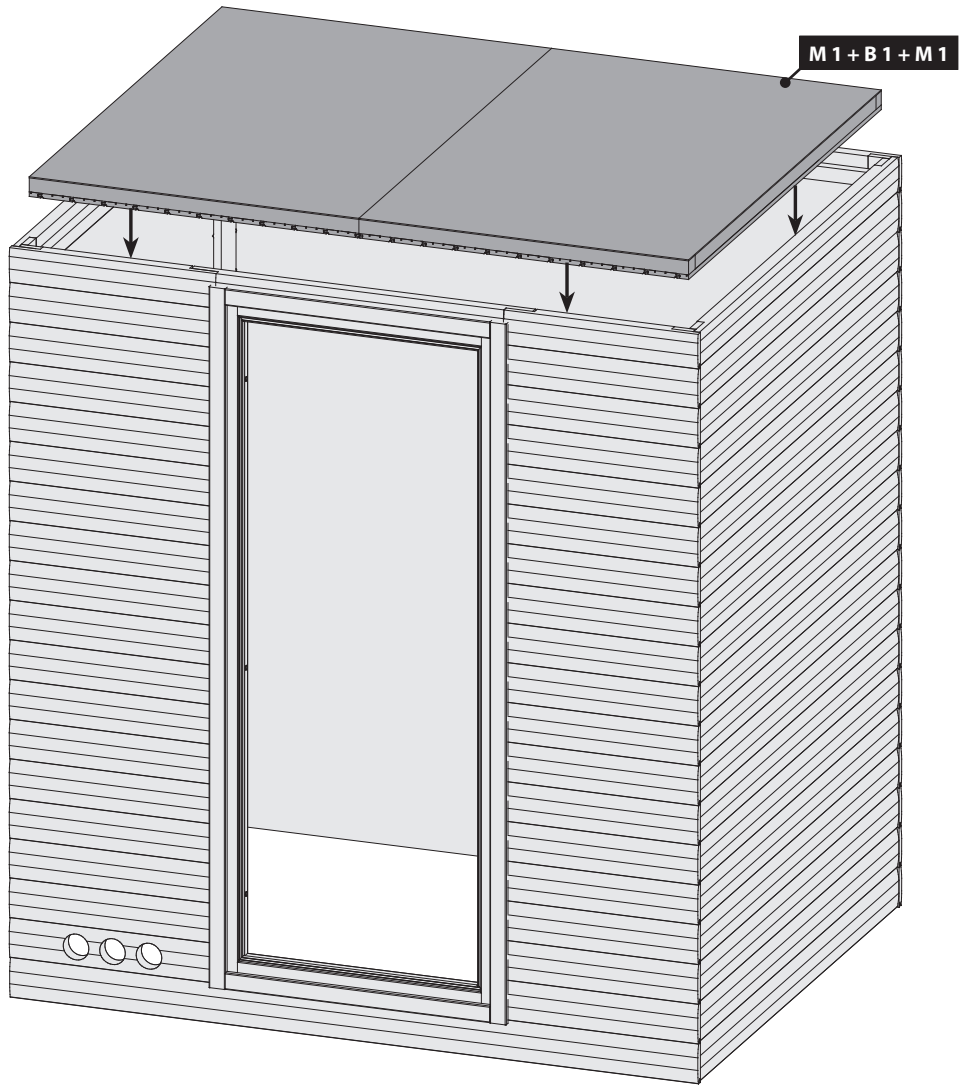

13

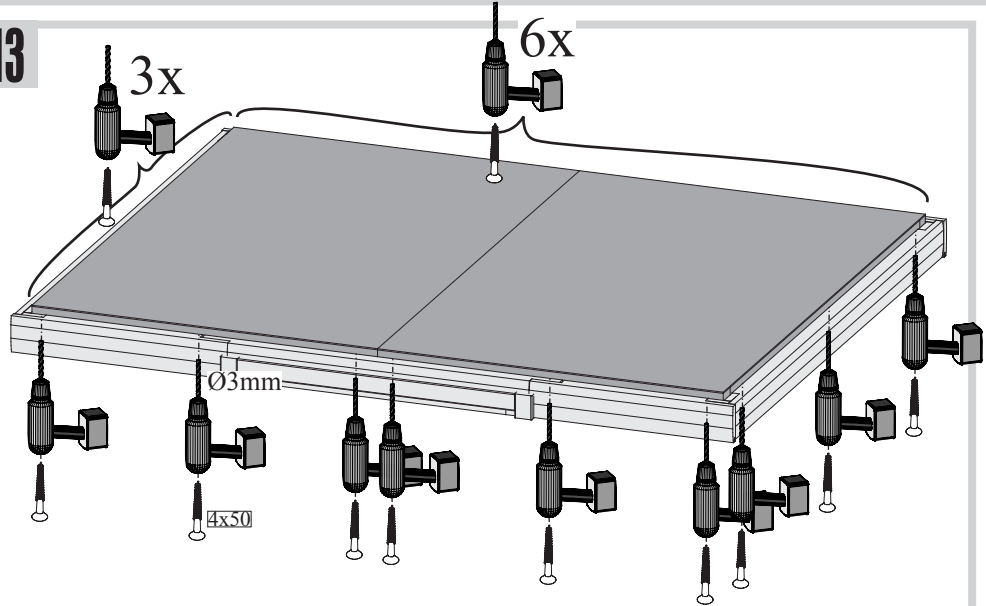

13.1

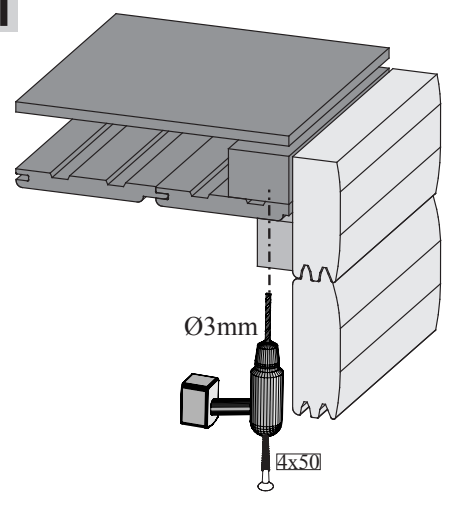

14

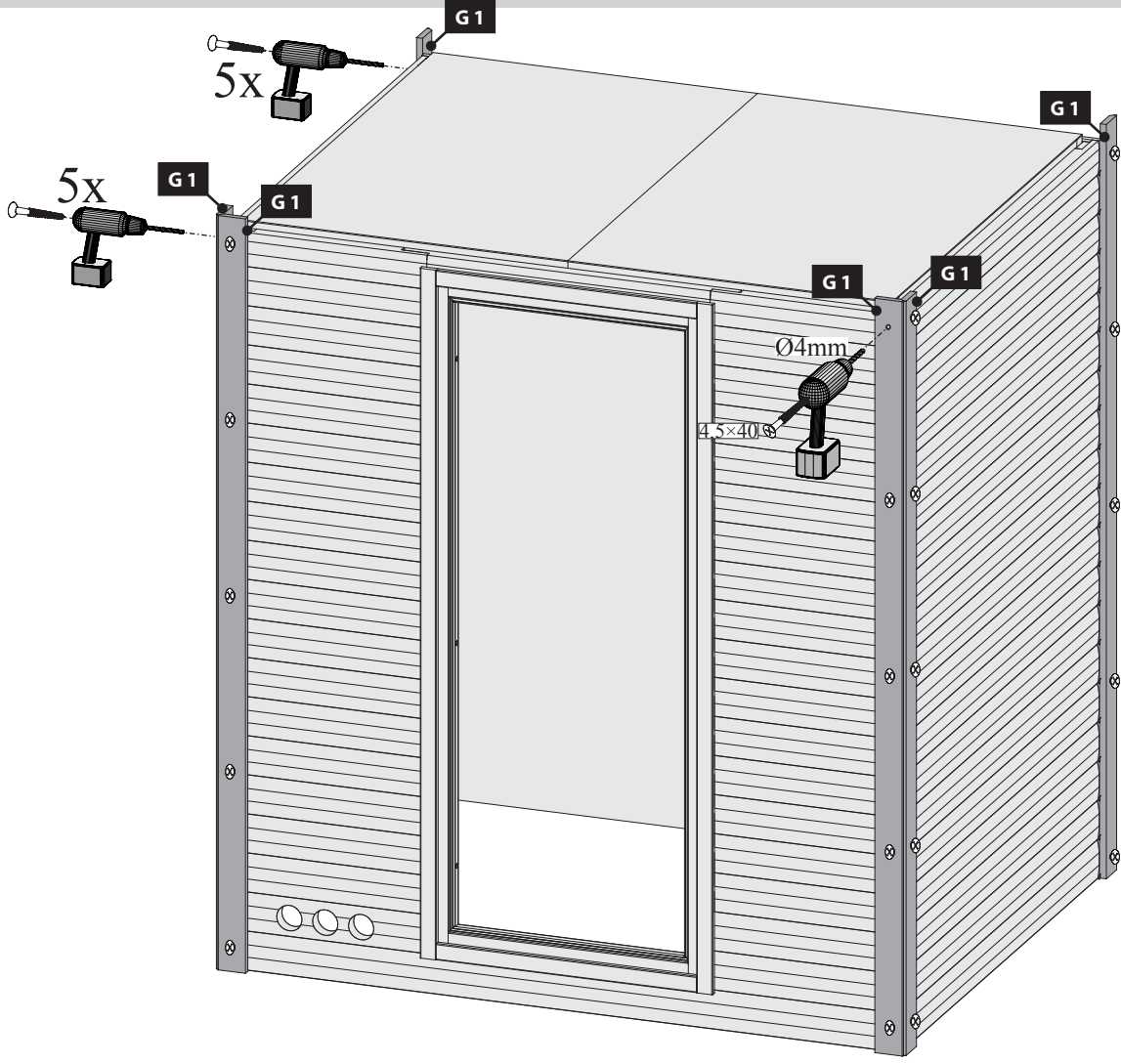

15

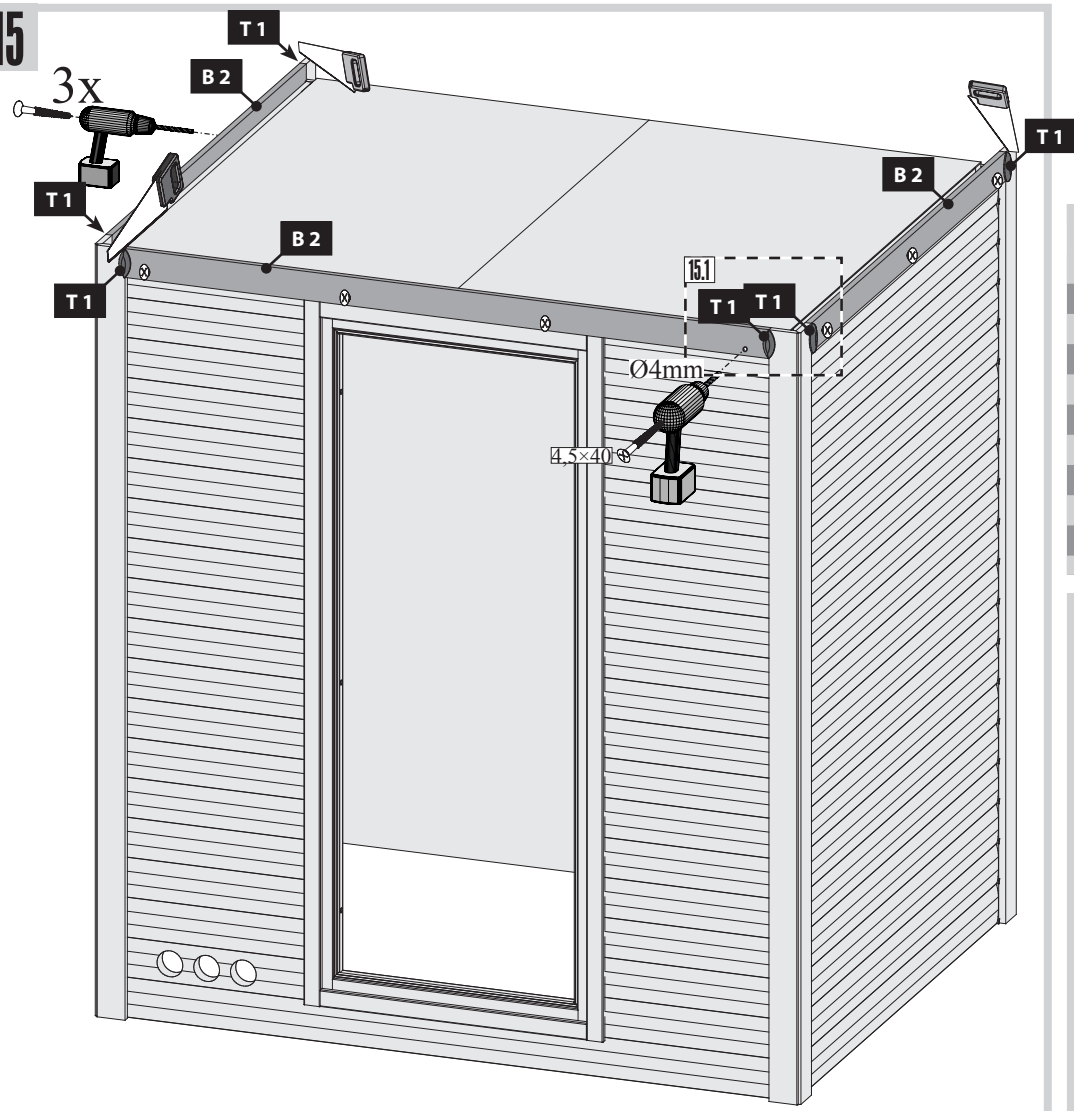

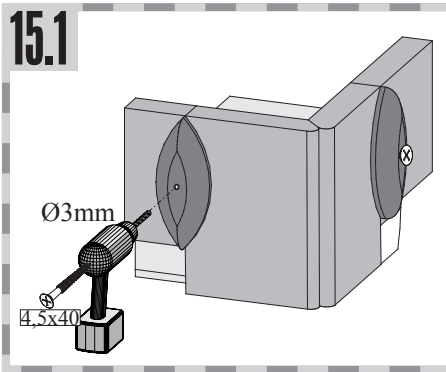

15.1



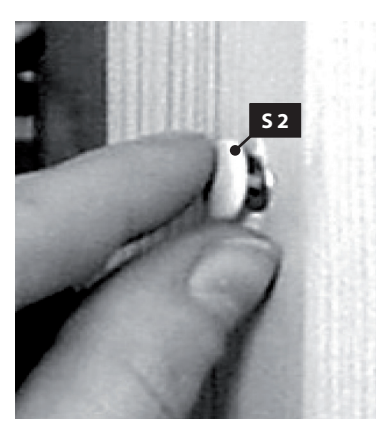

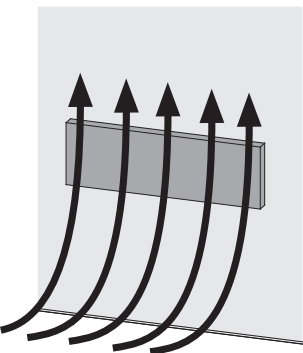
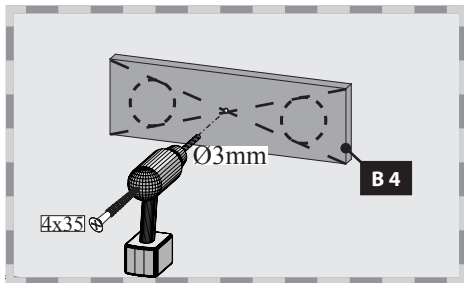
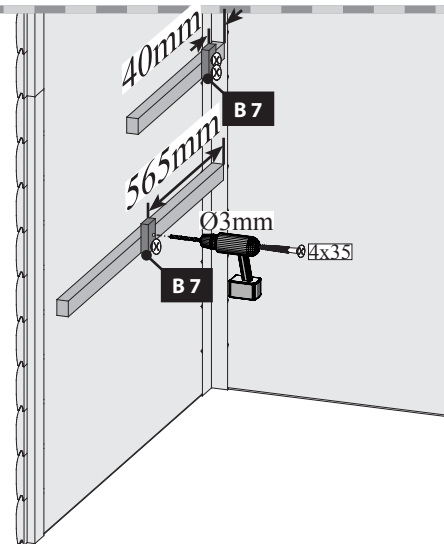
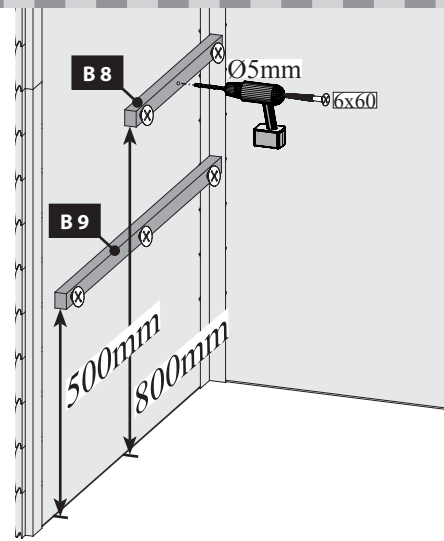
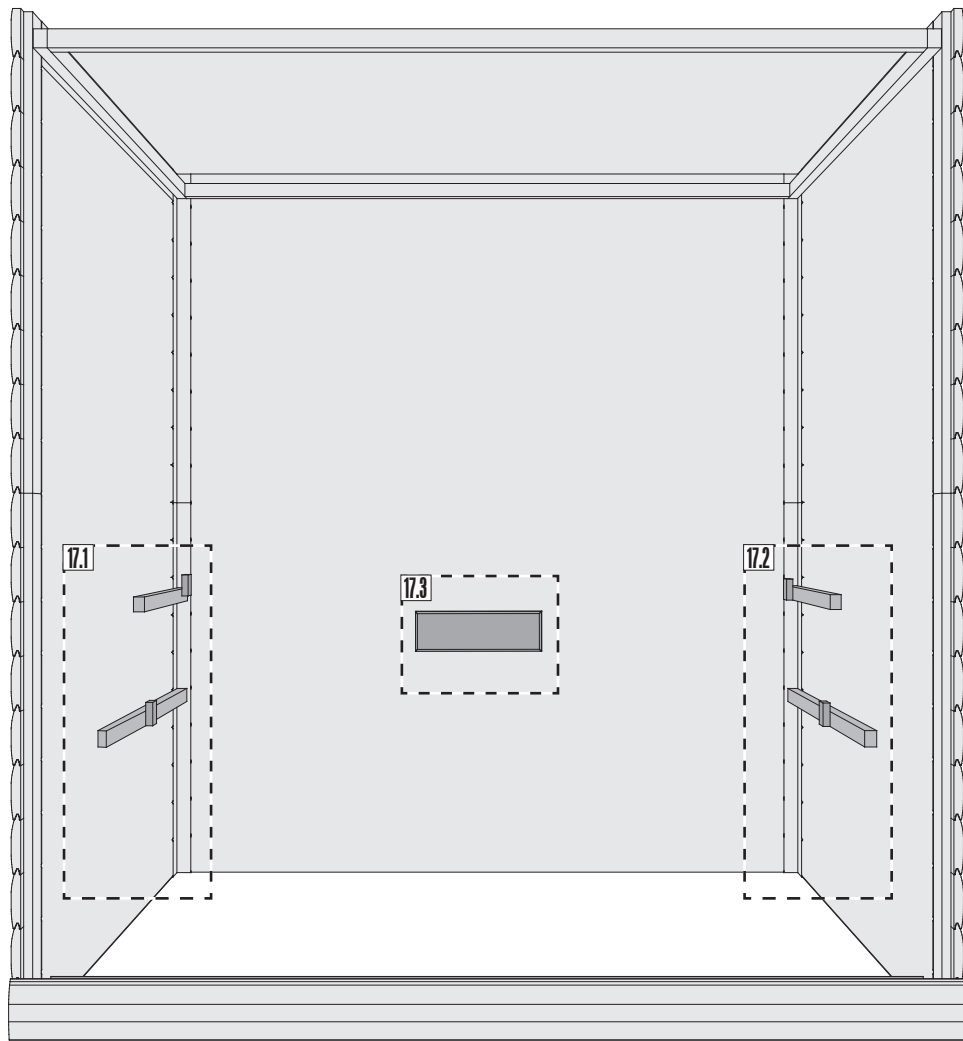
16





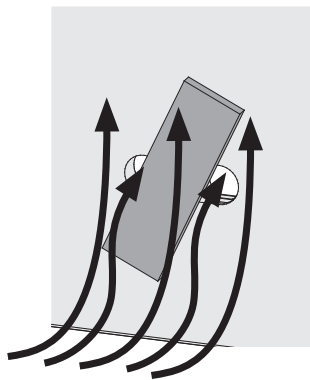

 Hier ist die Funktionsweise des Brettes abgebildet. Regeln Sie damit die Abluft nach Ihren eigenen Wünschen.



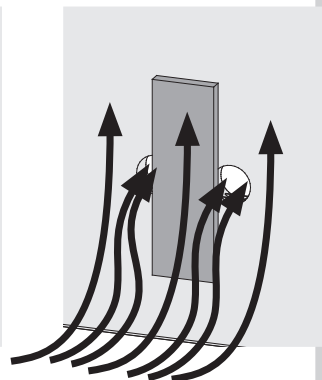

 Ceci représente le mode de fonctionnement de la planche. Avec elle, réglez l'écoulement de l'air selon vos désirs.

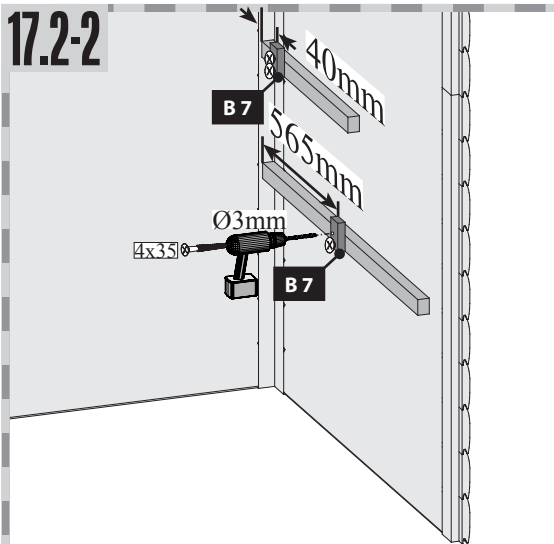
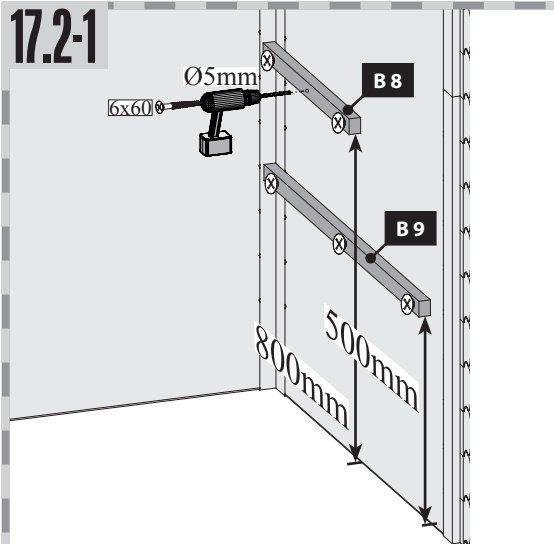

 This figure shows the functional principle of the board. Regulate the exhaust air according to your own wishes.



 Hier is de werking van het plankje afgebeeld. Regel daarmee de luchtafvoer naar eigen wens.

 Aquí está representada la forma de funcionamiento de la tabla. Regule con ello el aire de salida según sus propios deseos.

 Viene illustrato il principio di funzionamento della tavoletta di regolazione della ventilazione. Con essa si può regolare a piacere la ventilazione.

18

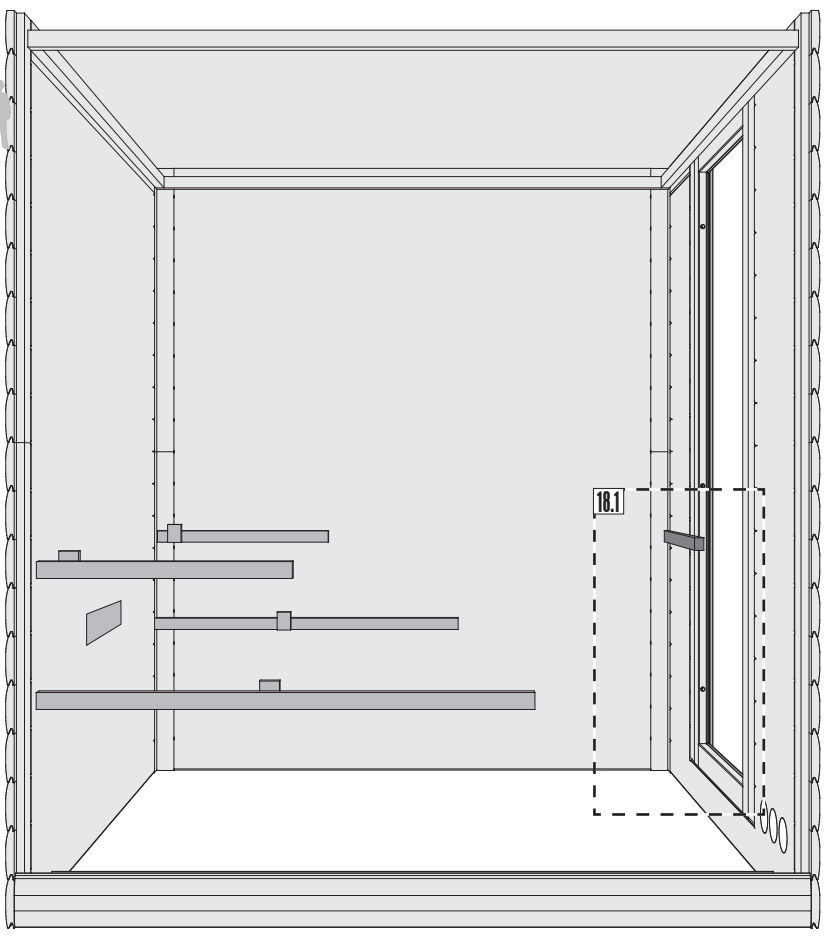
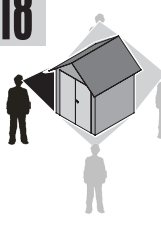

18.1-1

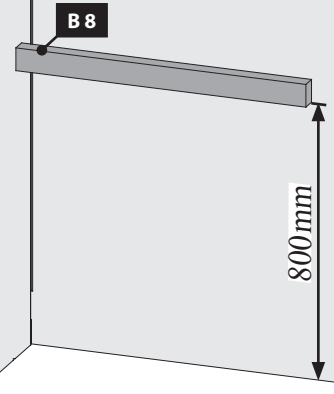

18.1-2

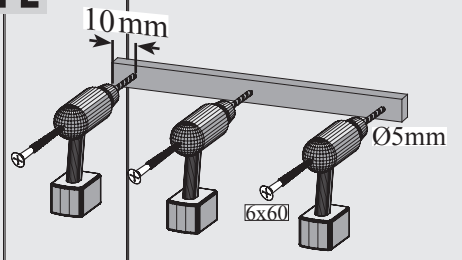

19

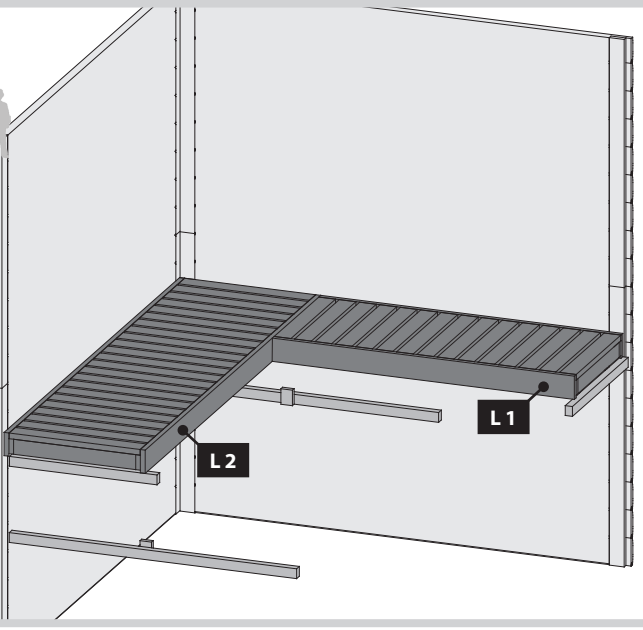
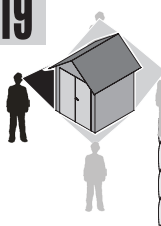

21

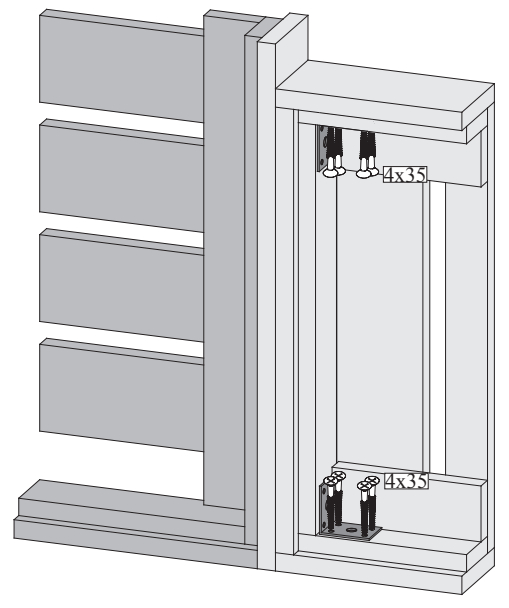

20

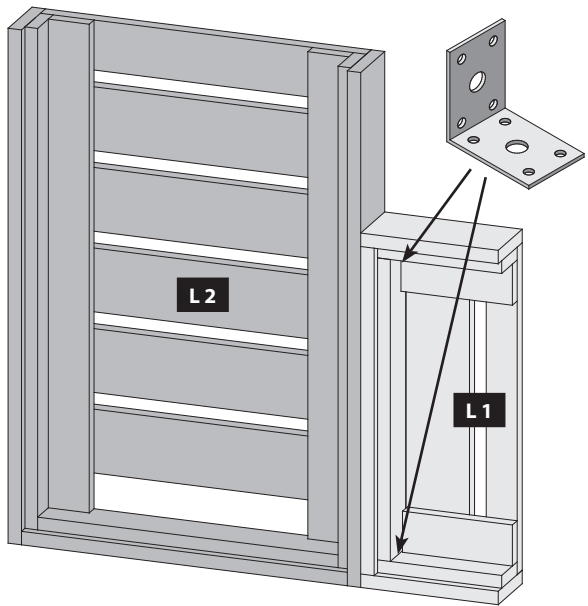
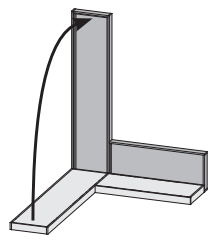

22

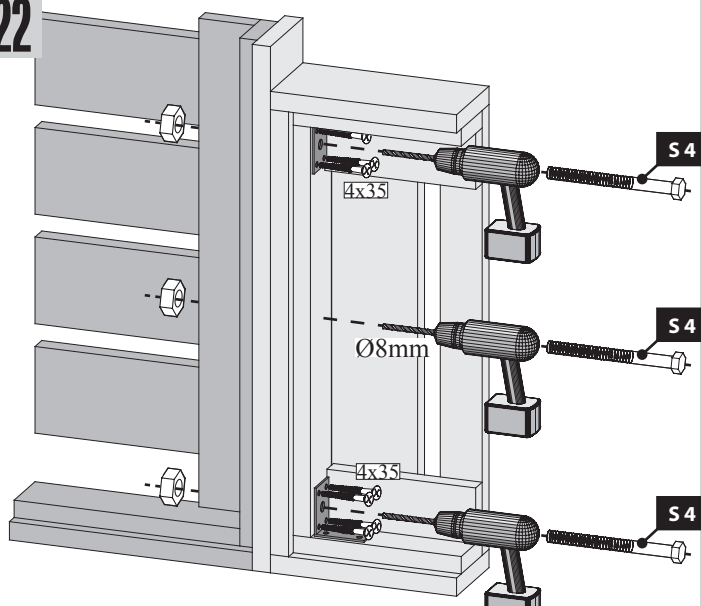

23

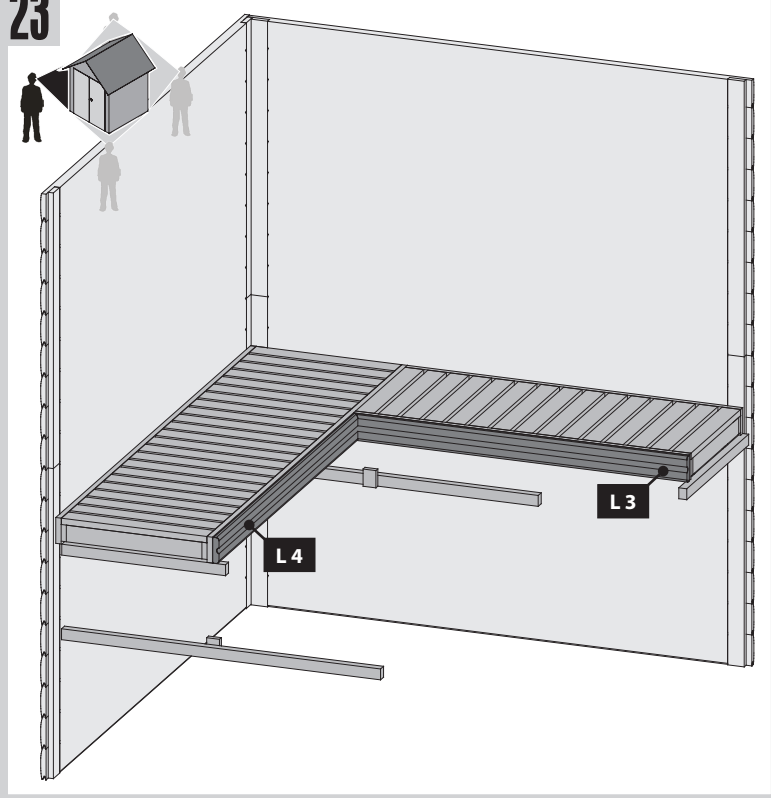

24

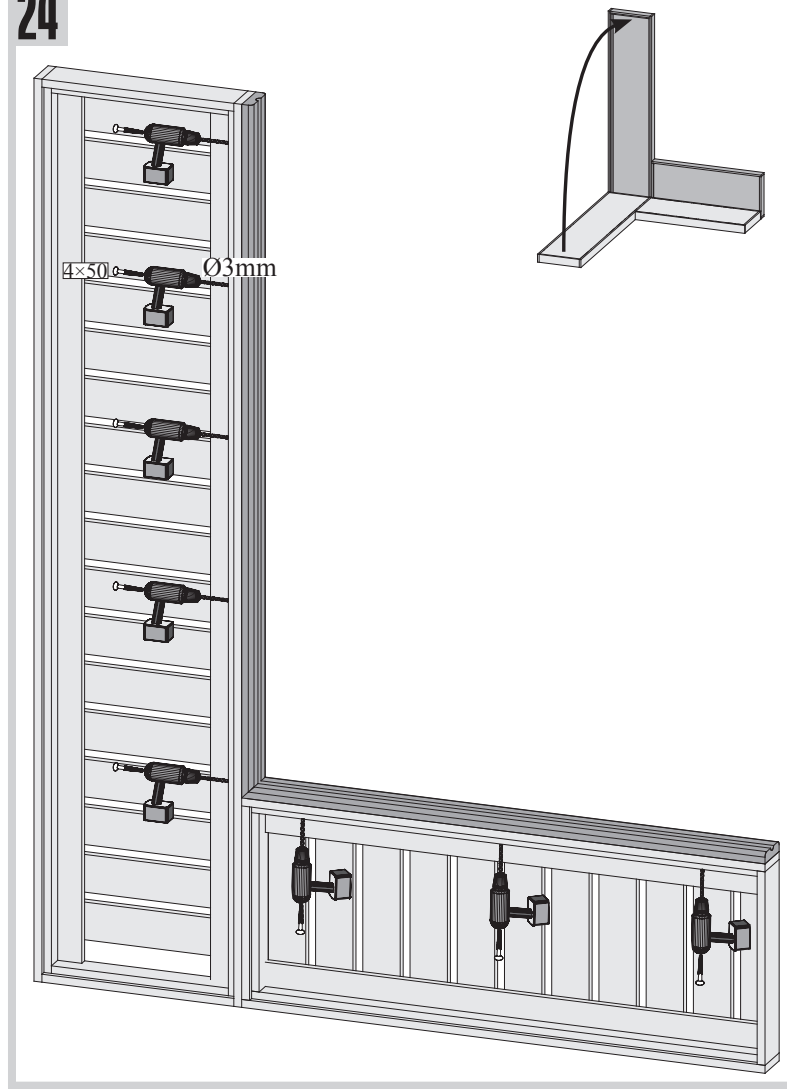

25

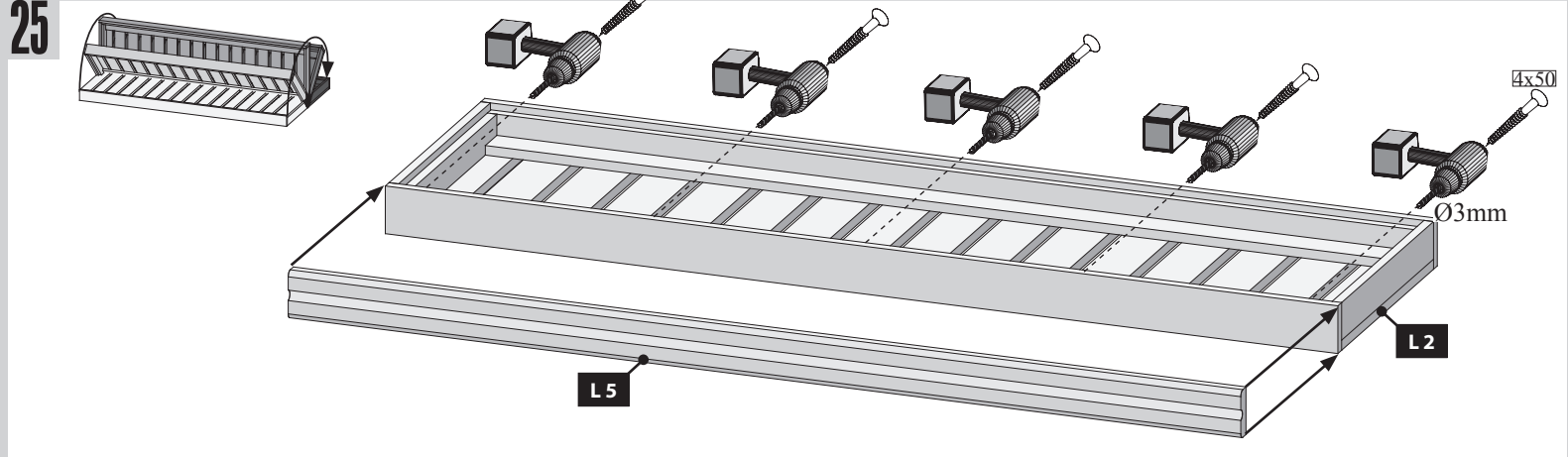

26

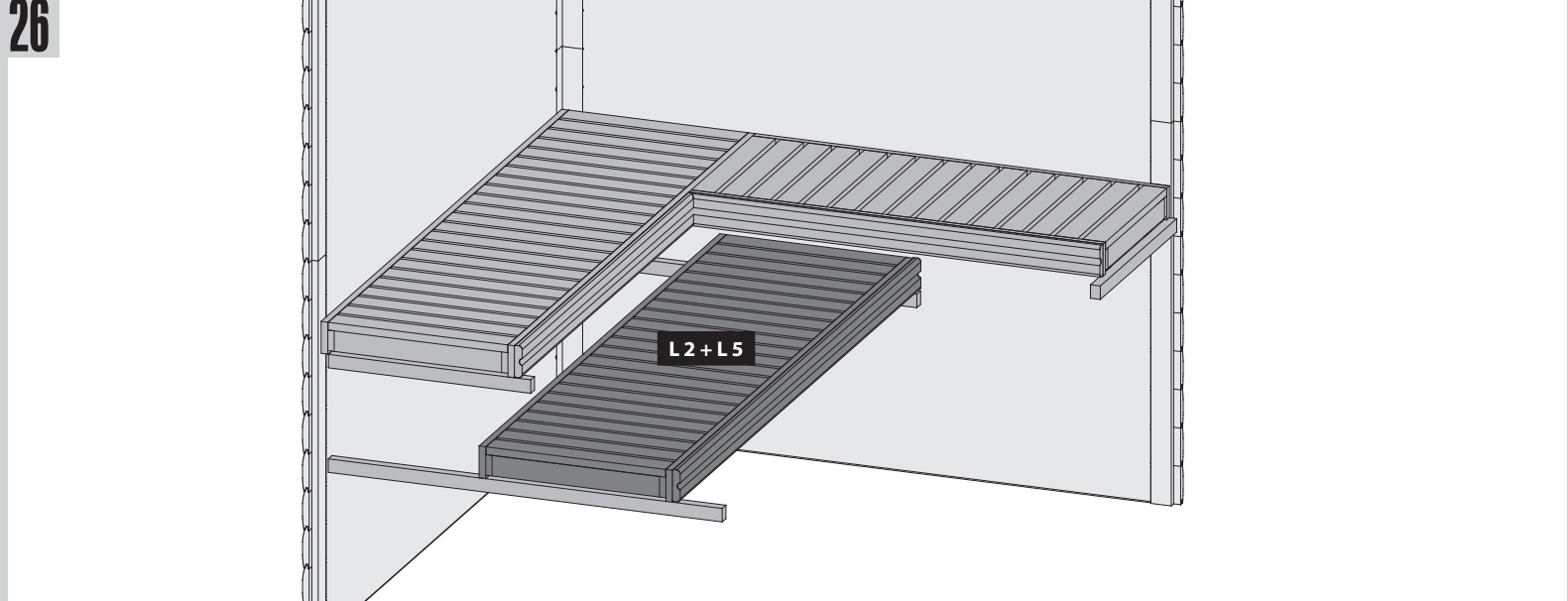

27 2x

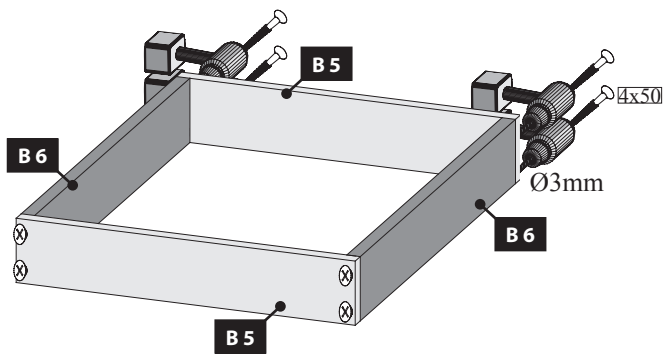

28

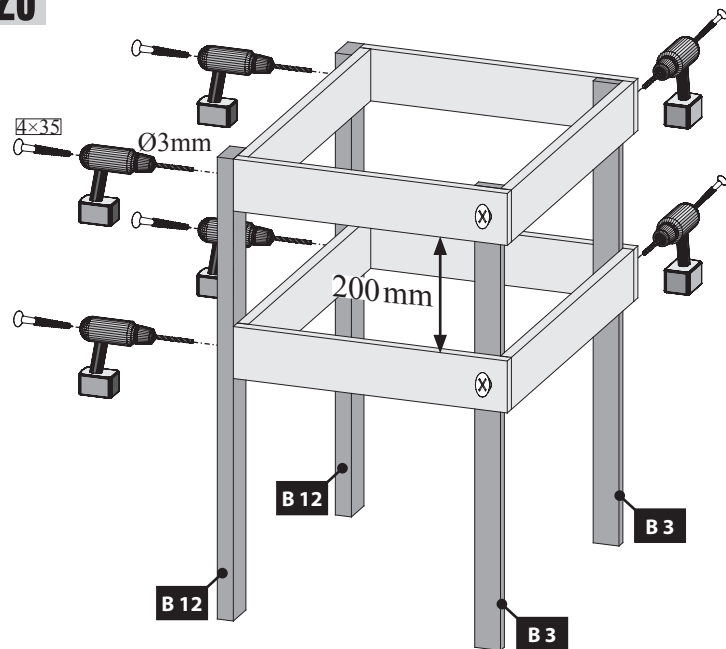

29

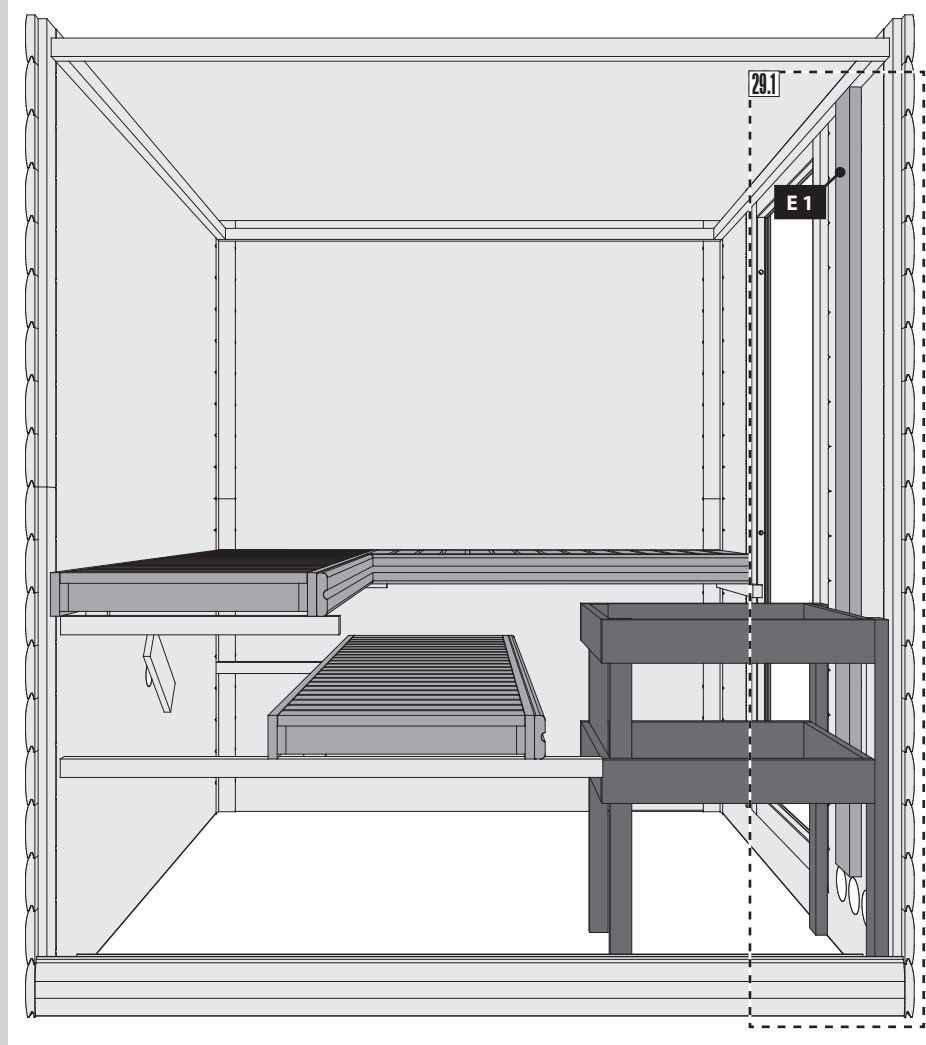

29.1

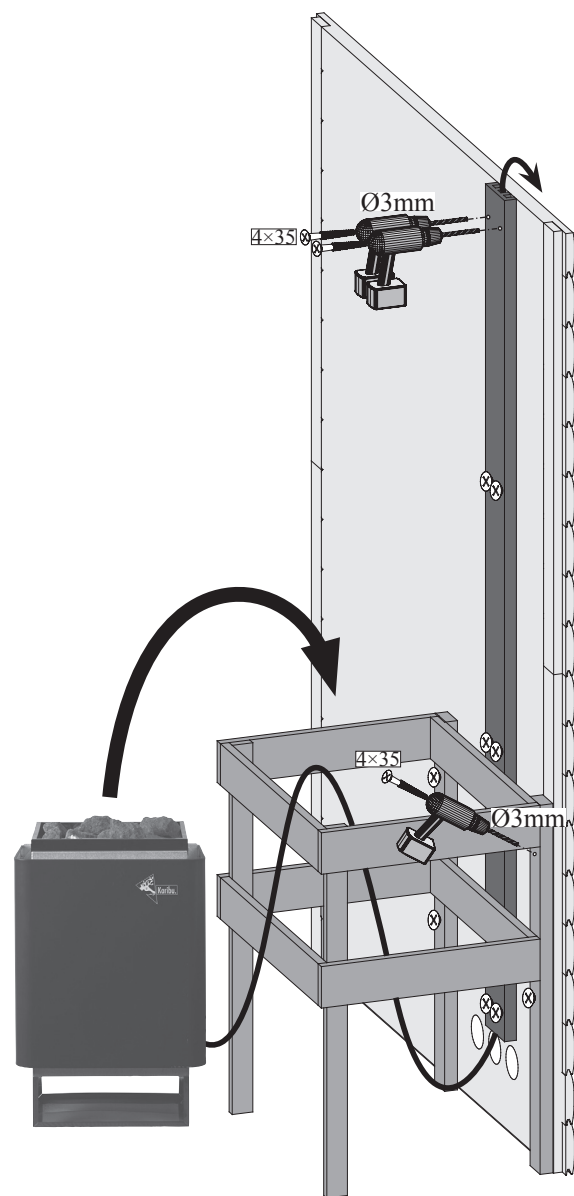

 Einbau Saunatür

 Installation de porte Sauna

 Sauna door installation

 Sauna deur installatie

 Instalación de la puerta Sauna

 Installazione porta Sauna

 Sauna Instalace dveře

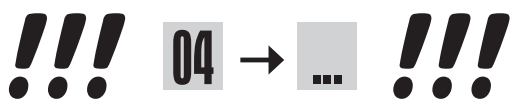

01

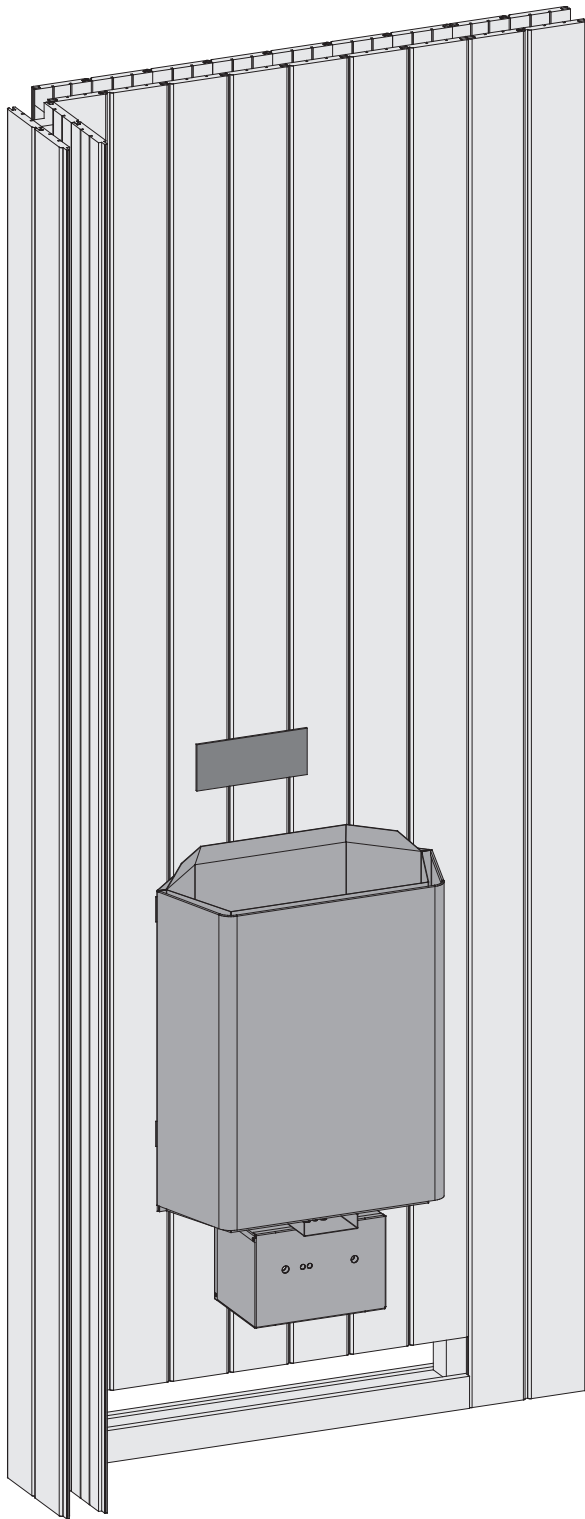

02

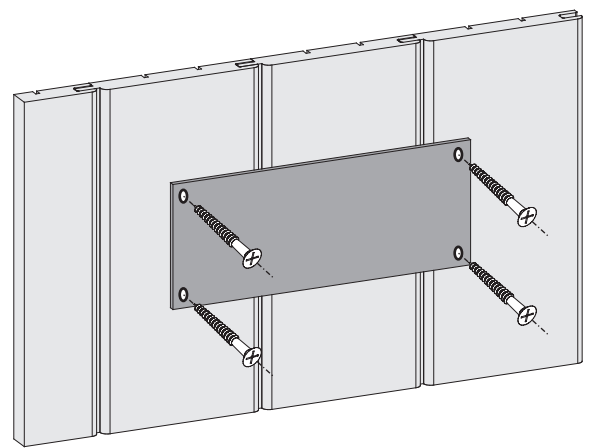

Entfernen Sie die Schutzfolie vom beiliegenden TÜV-Schild.

Lassen Sie den Saunaofen von einem zugelassenen Elektrofachmann anschließen. Dieser markiert den installierten Ofen auf dem TÜV-Schild.

Bringen Sie das TÜV-Schild an einer gut sichtbaren Stelle über dem Ofen an.

