

# Camargue® Star

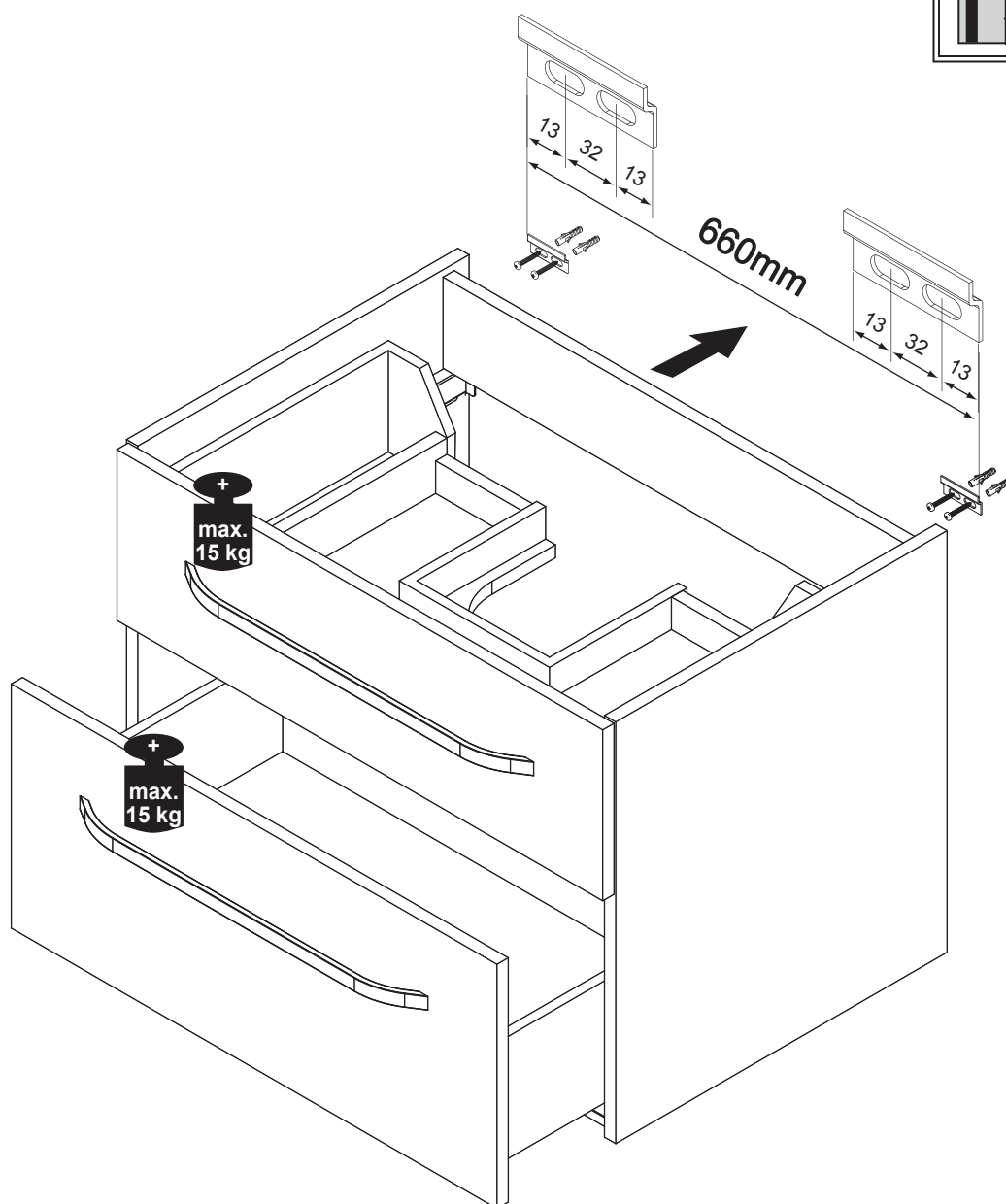
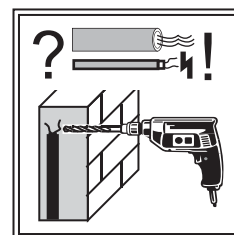
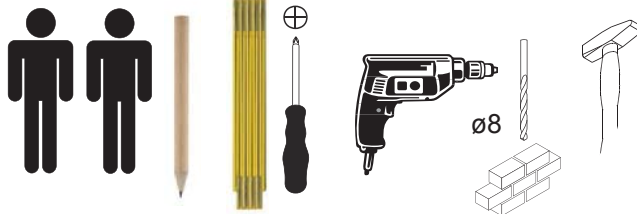

	WTU	WTU mit LED
Dark Oak	7074112	23769636
Weiß	7074312	7075312
Pinie	7074512	7075512
Eiche Maron	7074612	7075612
Grafit	7074712	7075712
	Seite 3-5	Seite 6-8

Hergestellt für:  
**BAHAG AG**  
 Gutenbergstrasse 21  
 68167 Mannheim

1

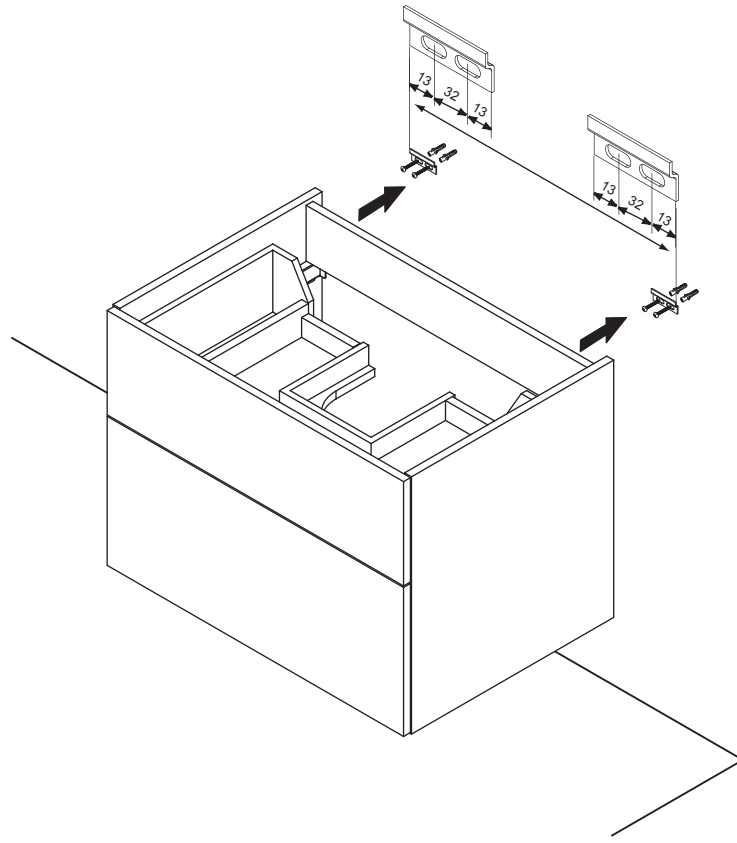

2

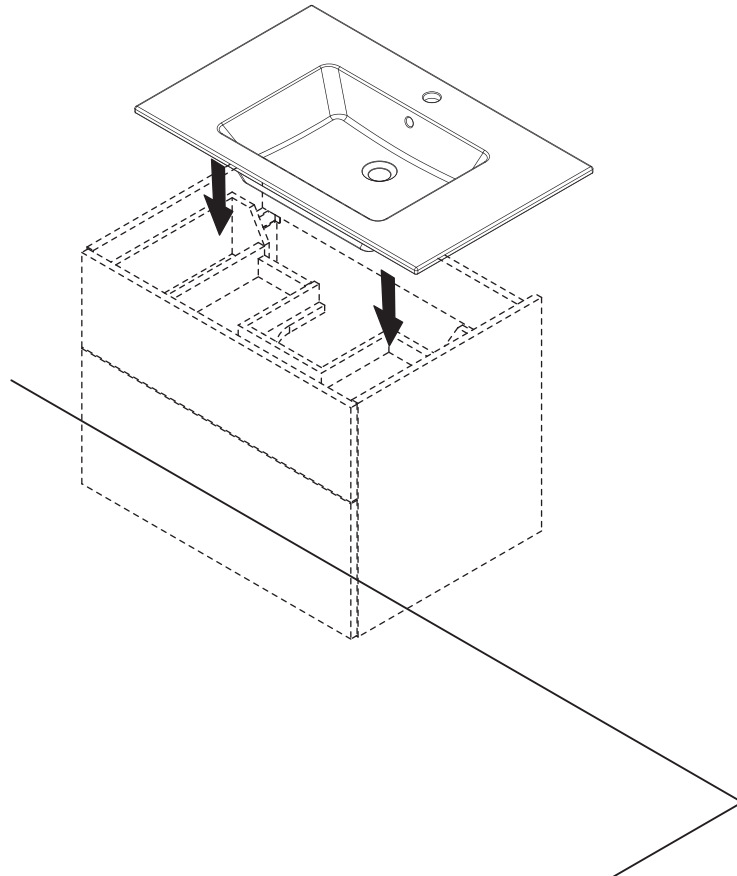

1

1

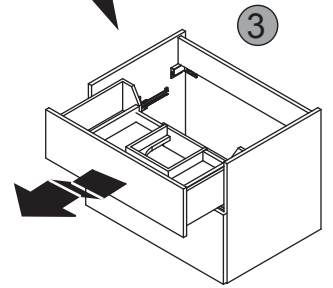
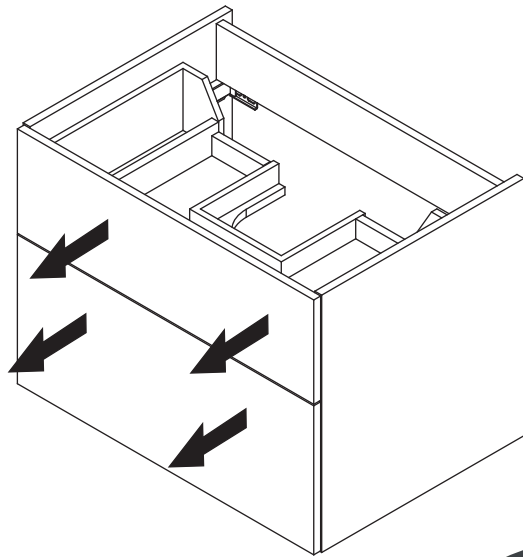

2

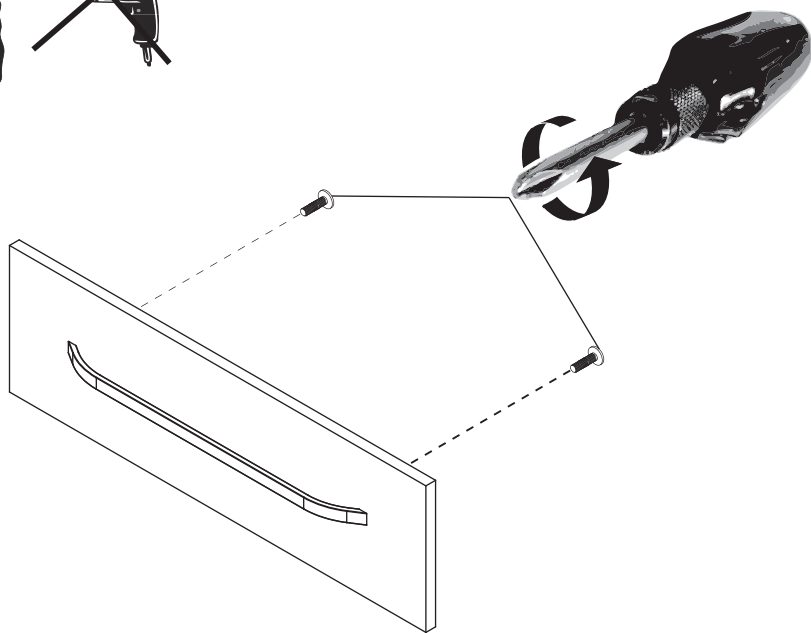

3

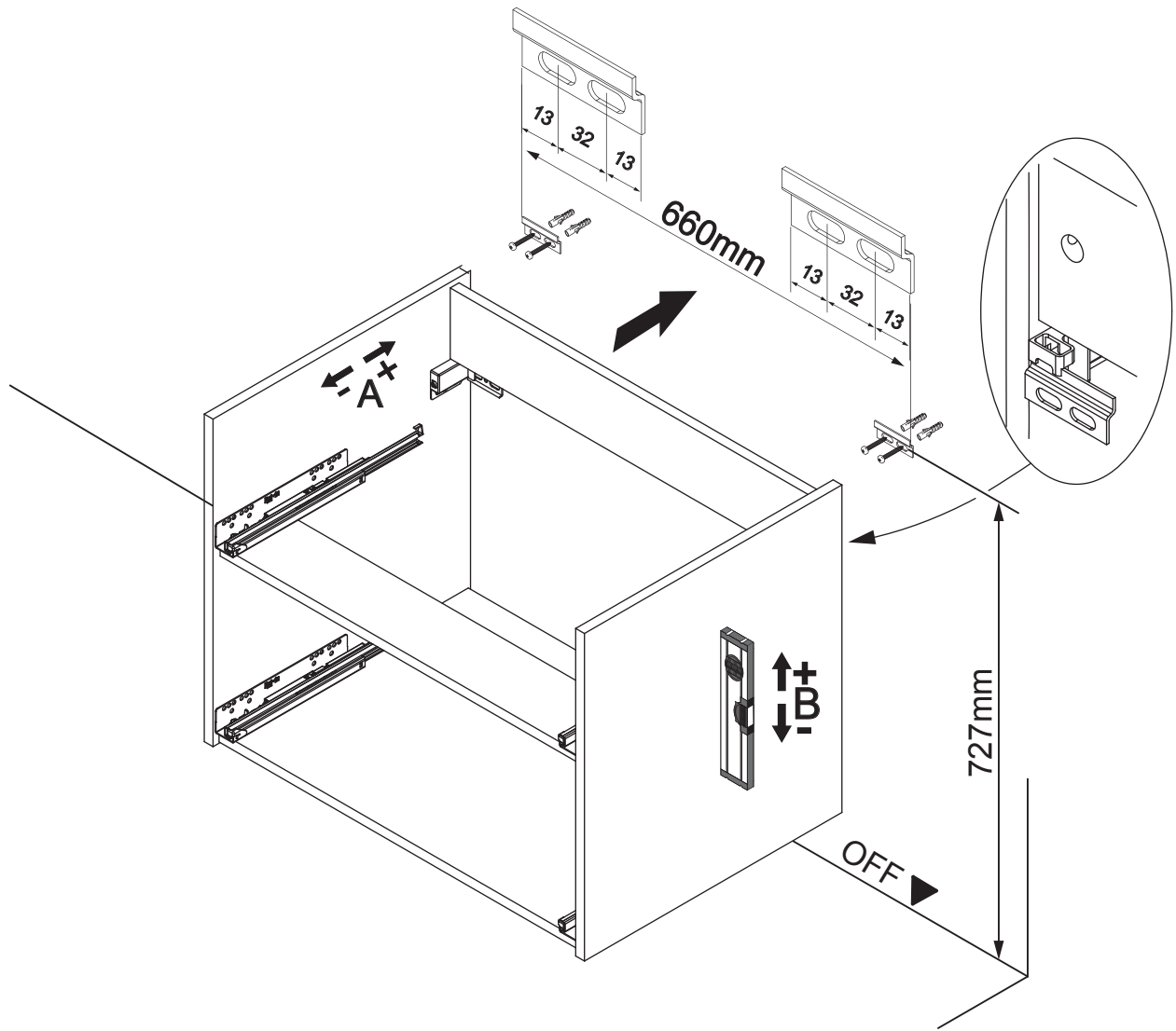
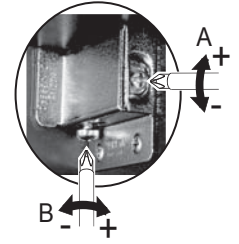
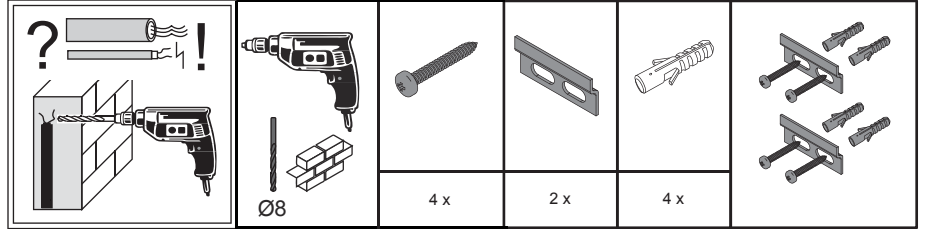

2



12 h



1

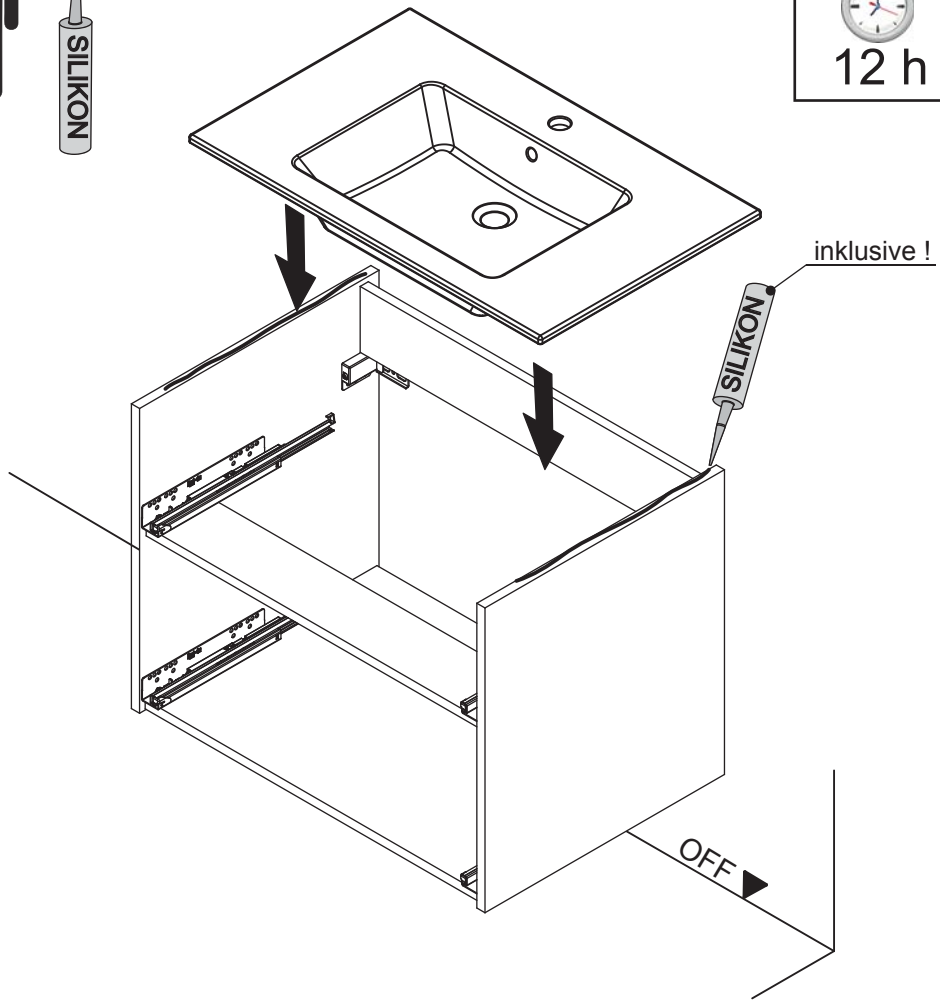

2

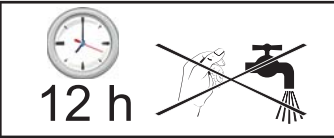

12 h

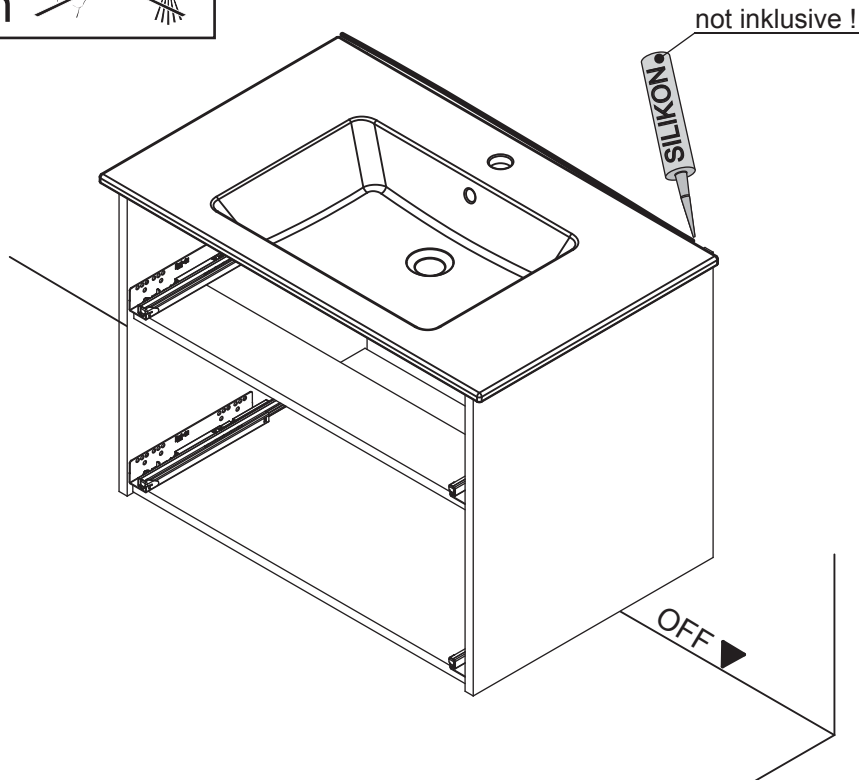

3

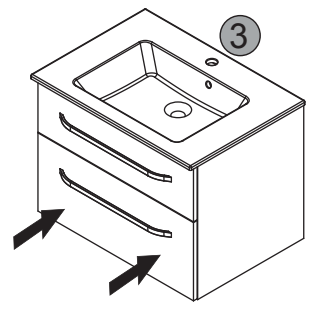
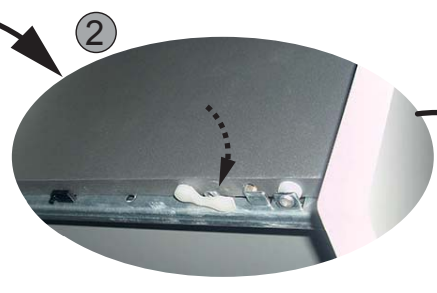
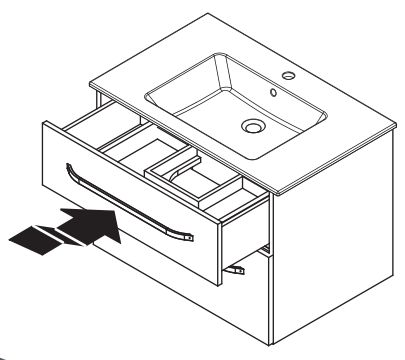

4

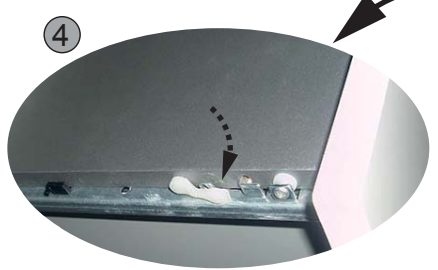
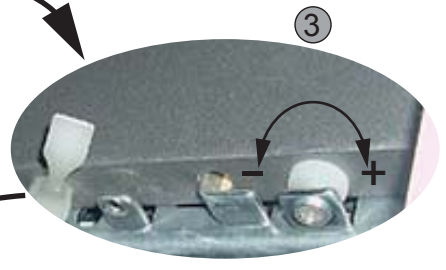
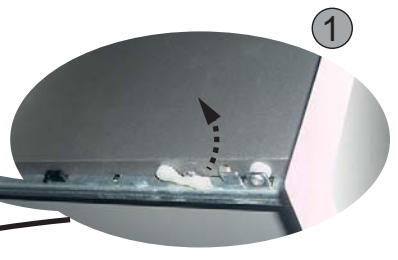
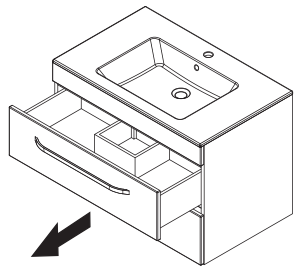
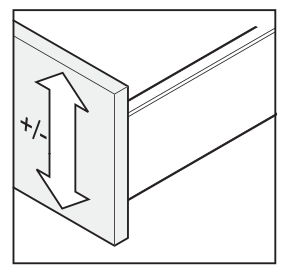

# Camargue Star

## Keramik-Waschtisch

Weiß 7076012

## Waschtischunterschrank

Farbe	Artikel-Nr.
Dark Oak	7074112
Weiß	7074312
Pinie	7074512
Eiche Maron	7074612
Grafit	7074712

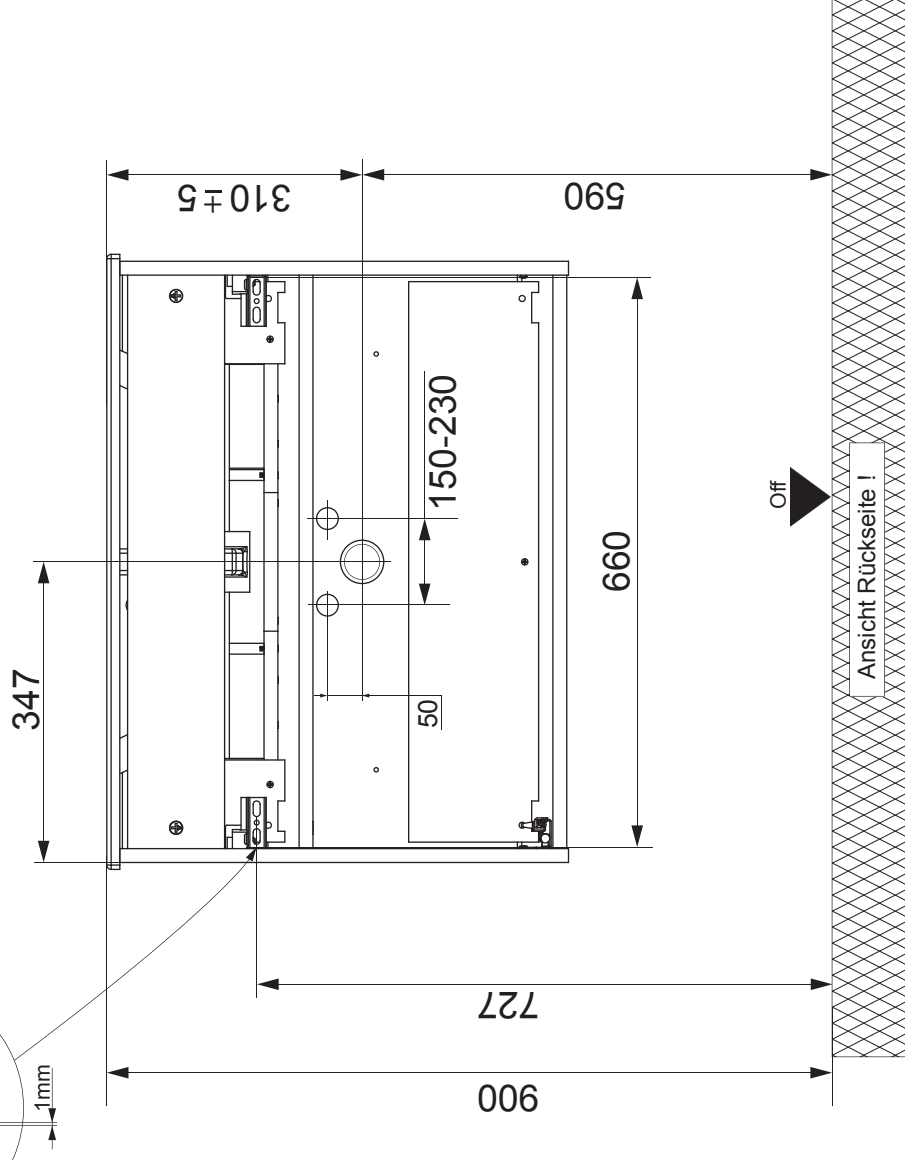
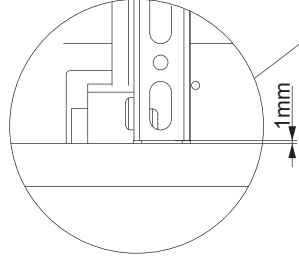
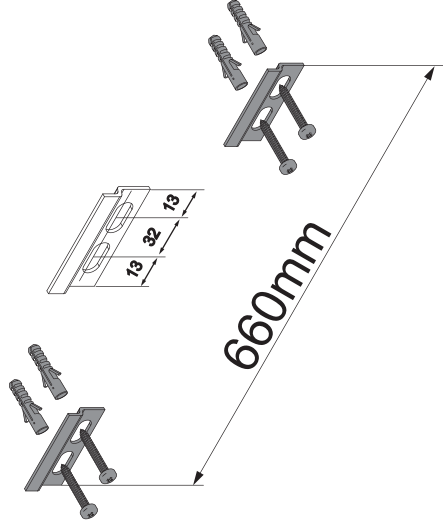

### Achtung:

Änderungen aufgrund technischer Weiterentwicklung bleiben uns vorbehalten.  
Maßangaben in mm.  
Bohrmaße sind vor Ort zu prüfen

### Hinweis:

Die vorgegebenen Maße sind unverbindlich und stellen nur eine Empfehlung dar!

# Camargue<sup>®</sup>

## Star

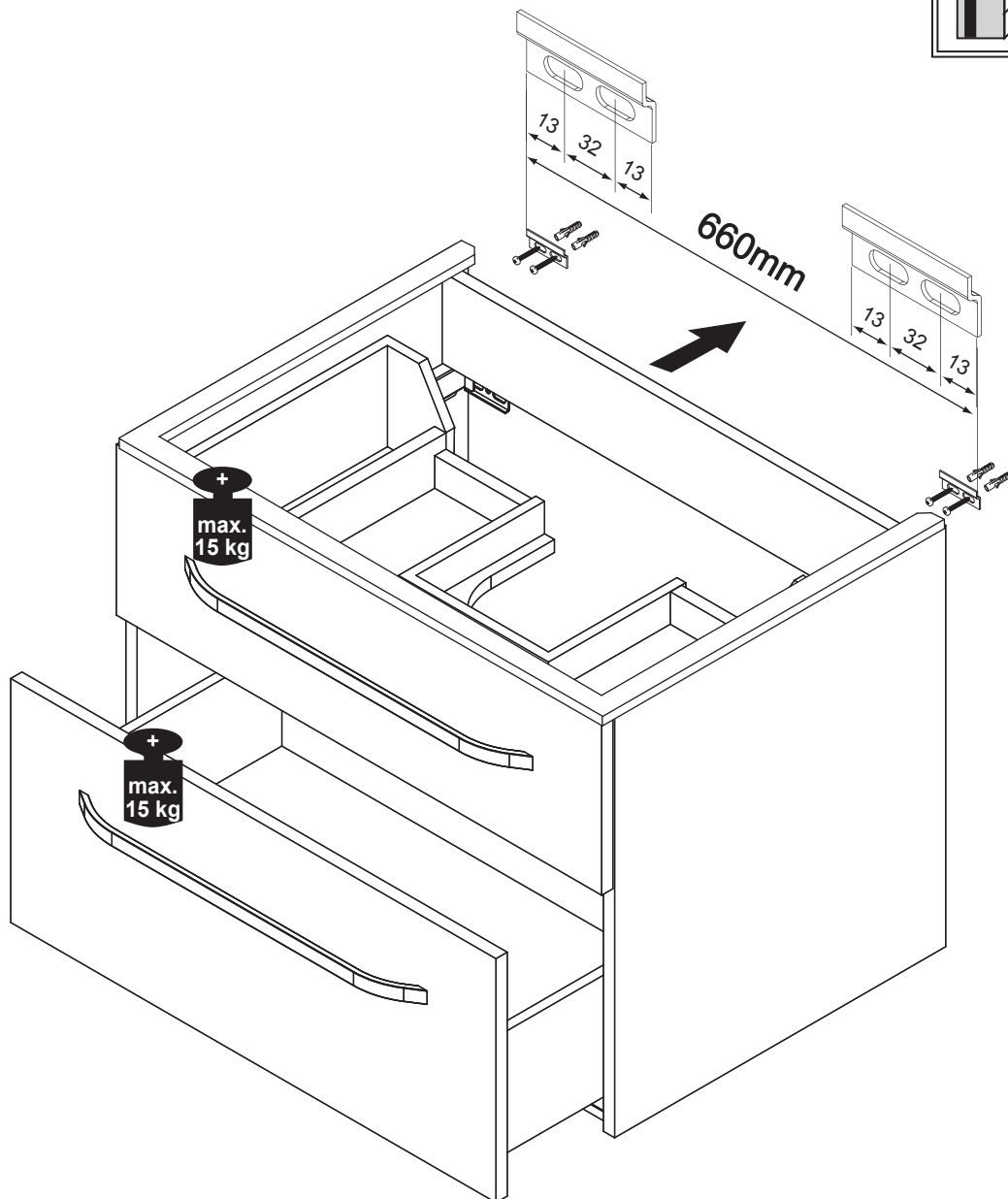
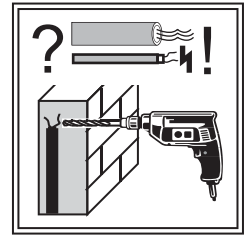
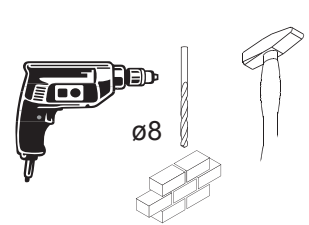
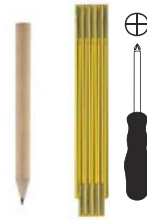

WTU mit LED	
Dark Oak	23769636
Weiß	7075312
Pinie	7075512
Eiche Maron	7075612
Grafit	7075712

Hergestellt für:  
**BAHAG AG**  
 Gutenbergstrasse 21  
 68167 Mannheim



1

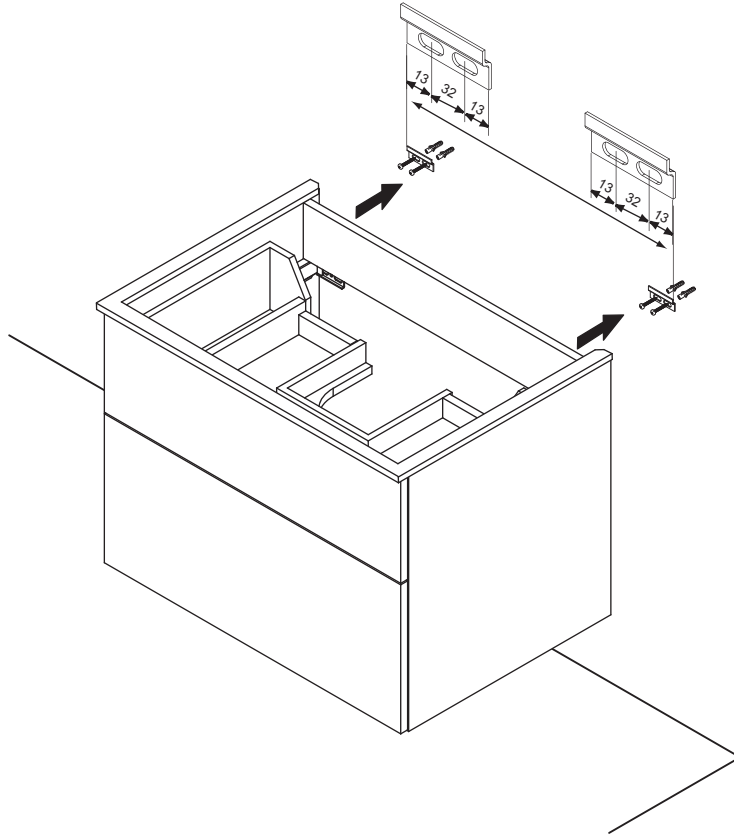

2

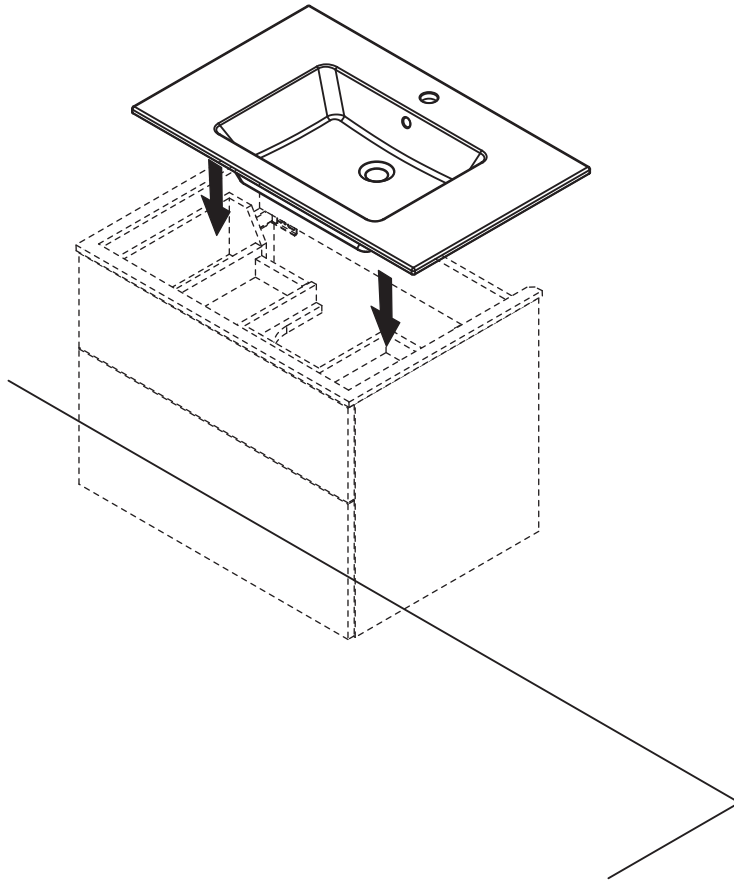

1

1

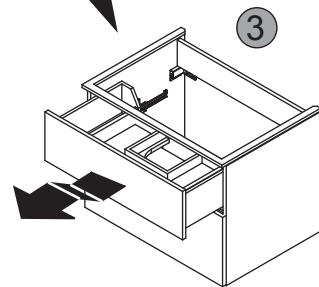
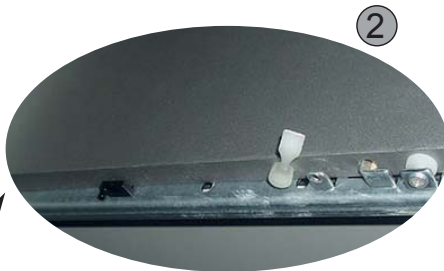
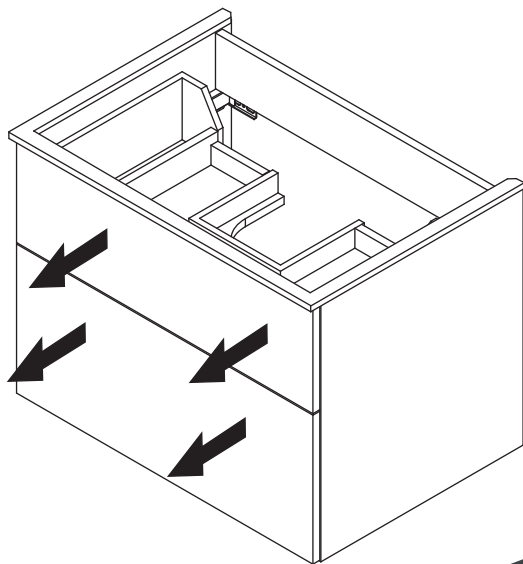

2

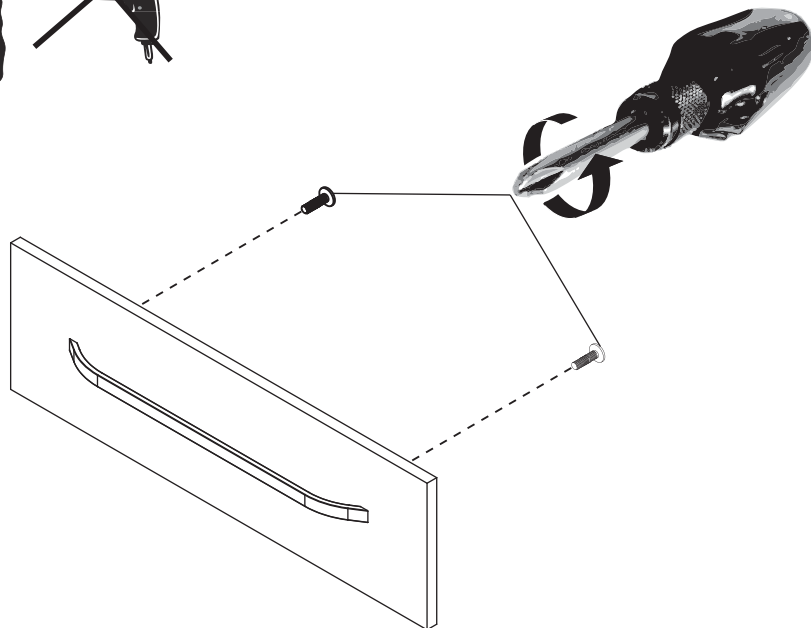

3

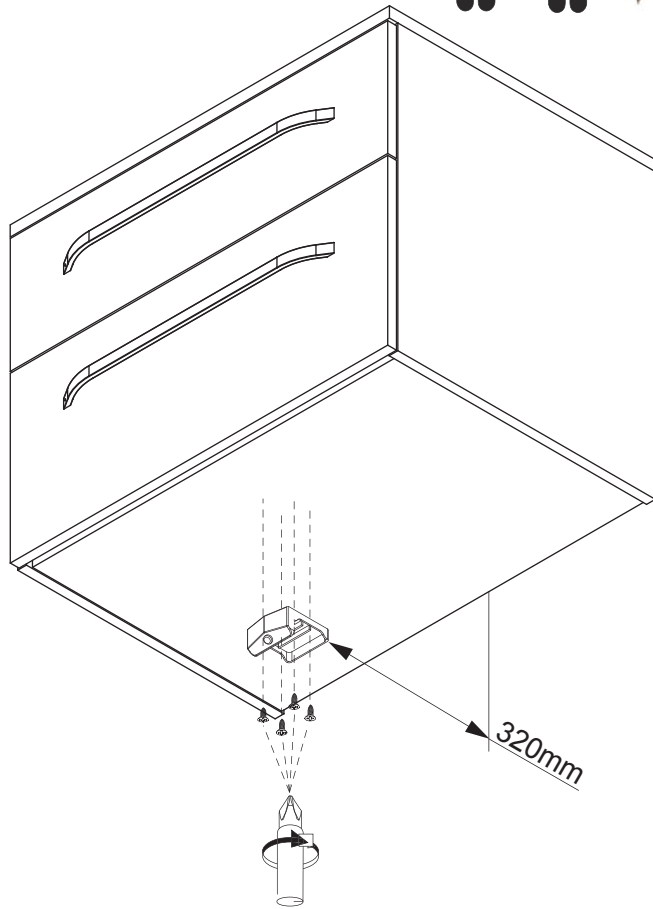
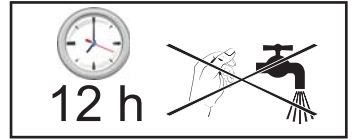
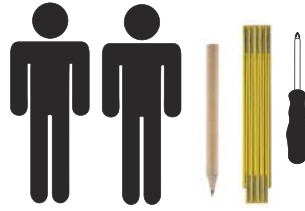

4

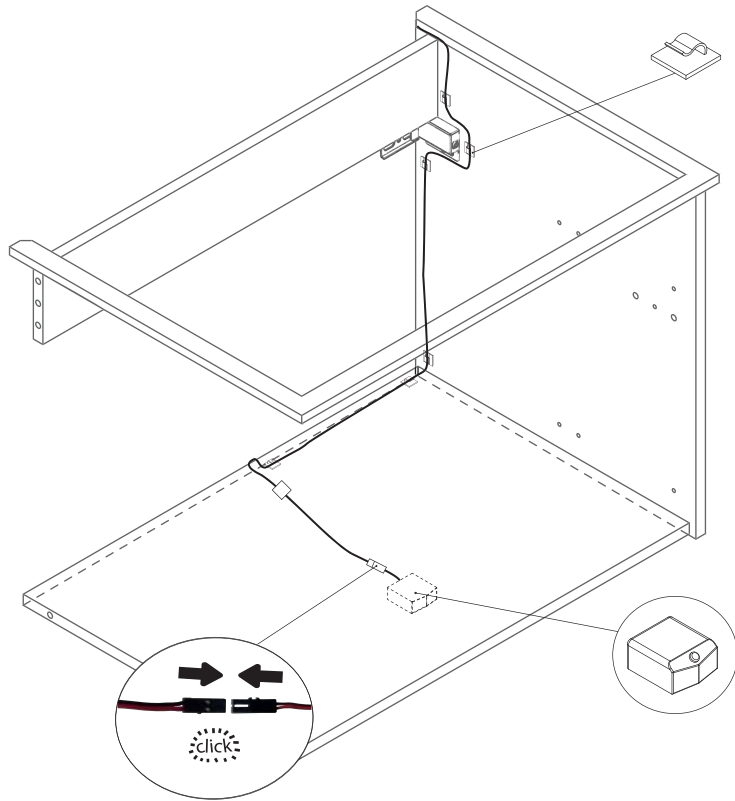

5

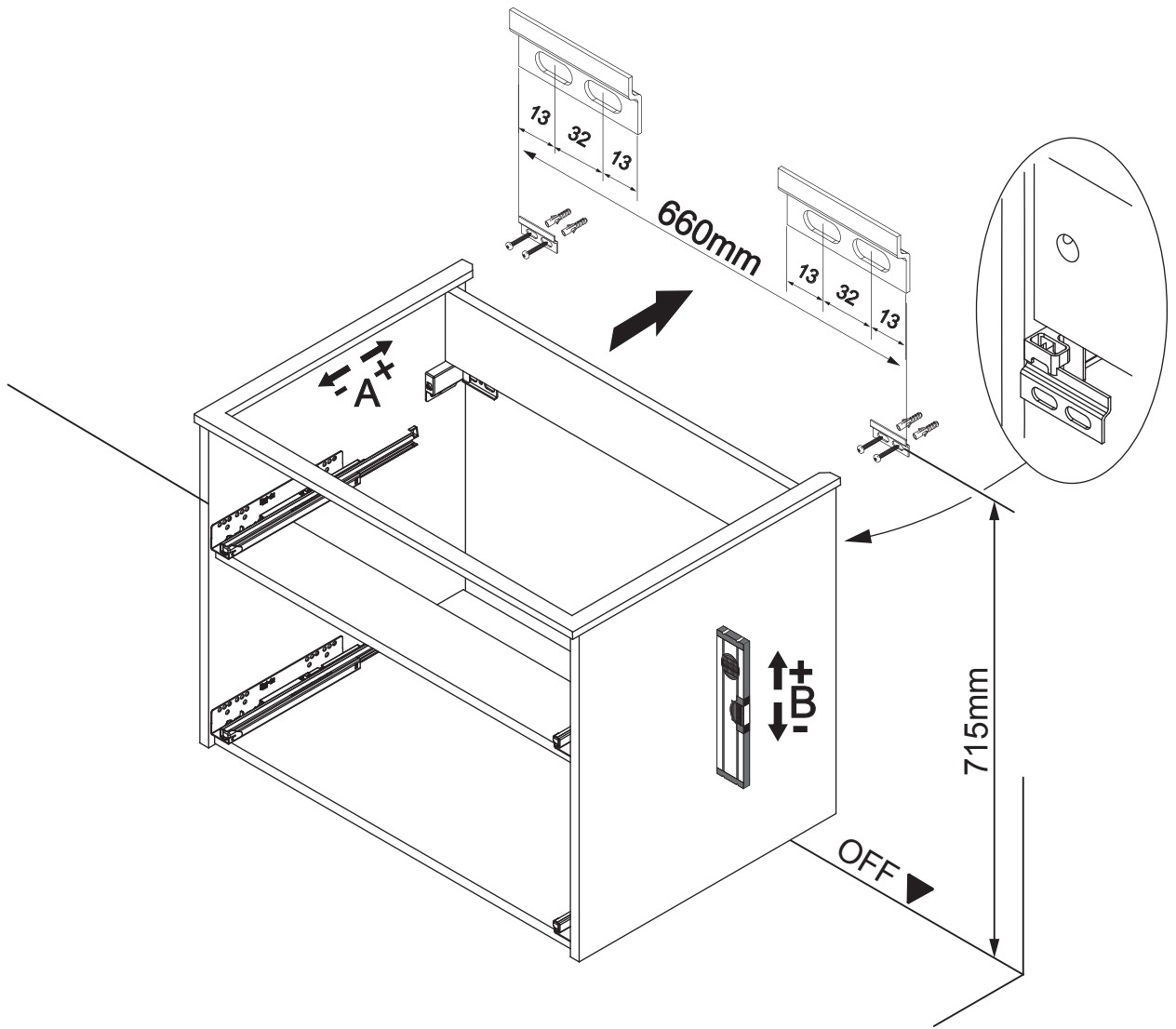
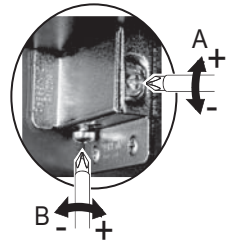
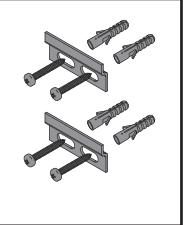
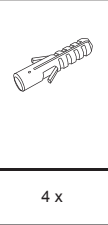
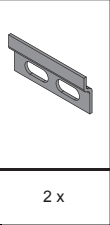
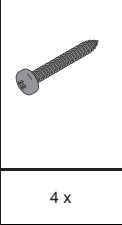
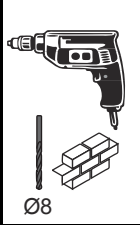
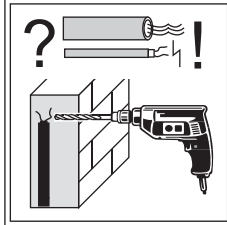

2



12 h

1

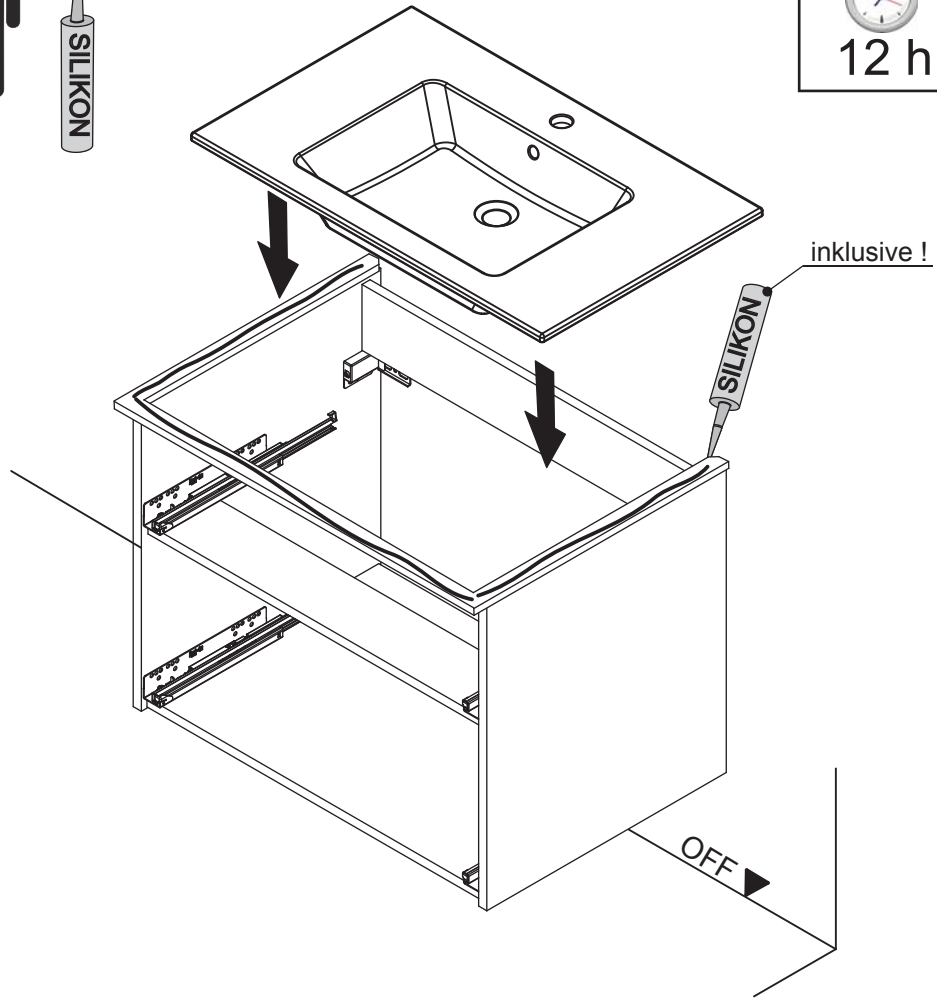

2

12 h

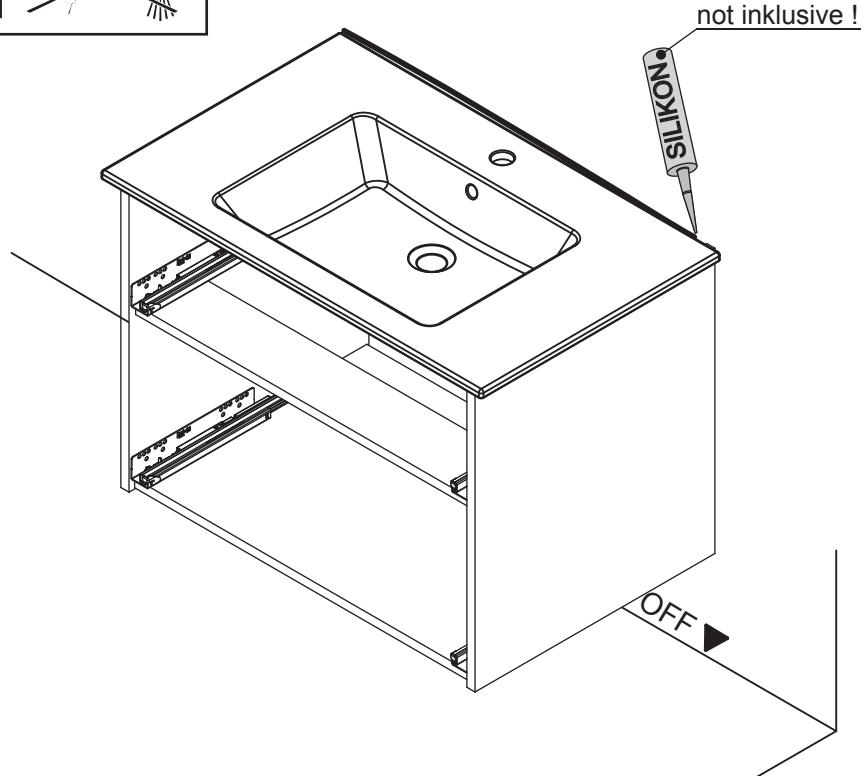

3

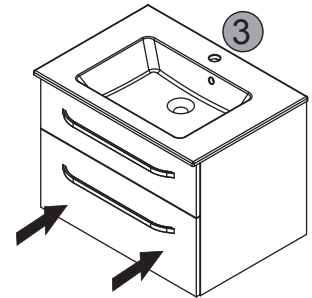
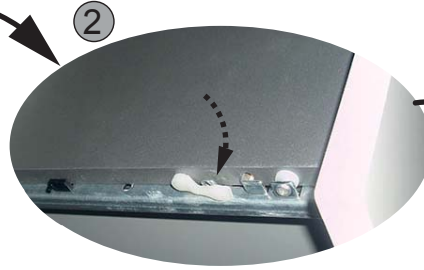
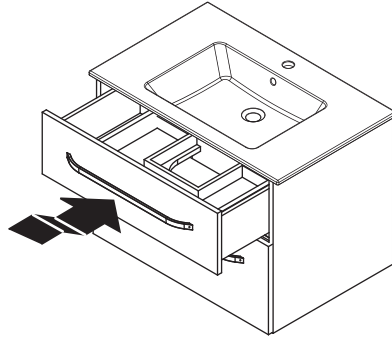

4

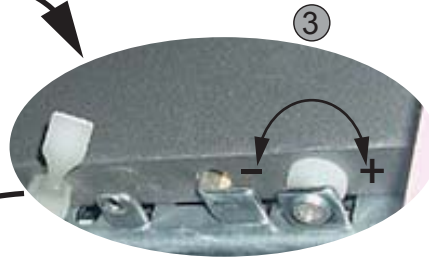
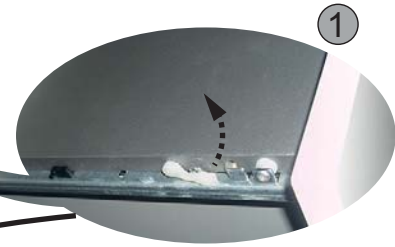
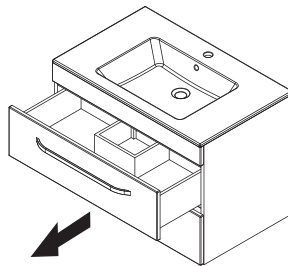
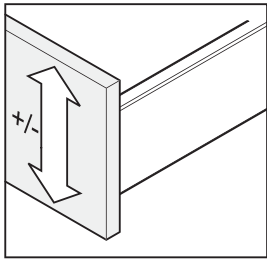

# Camargue Star

Keramik-Waschtisch

Weiß 7076012

## Waschtischunterschrank

Farbe	Artikel-Nr. WTU mit LED
Dark Oak	23769636
Weiß	7075312
Pinie	7075512
Eiche Maron	7075612
Grafit	7075712

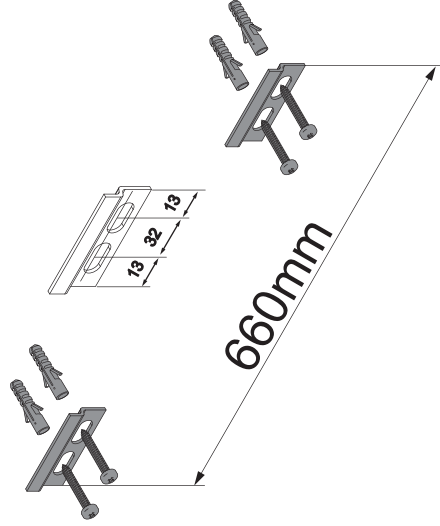

**Achtung:**  
Änderungen aufgrund technischer Weiterentwicklung bleiben uns vorbehalten.  
Maßangaben in mm.  
Bohrmaße sind vor Ort zu prüfen

**Hinweis:**  
Die vorgegebenen Maße sind unverbindlich und stellen nur eine Empfehlung dar !

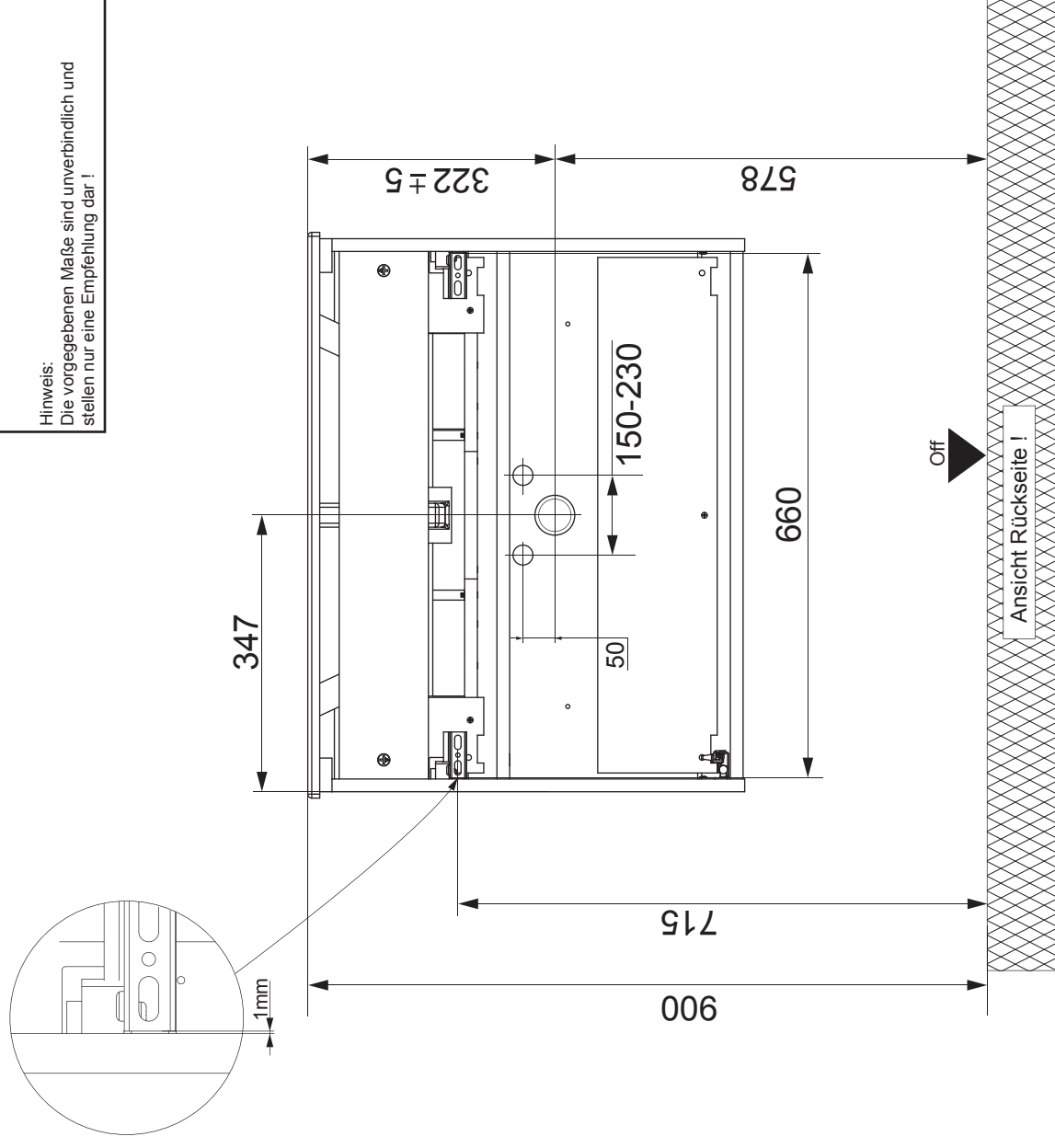

## D Montagehinweise

DIE MONTAGE IST DURCH EINE FACHKUNDIGE PERSON DURCHZUFÜHREN.

Vor Gefahr bei fehlerhafter Montage wird gewarnt. Bei Schäden an Möbeln oder Personen, die durch fehlerhafte Montage oder durch die Montage durch eine nichtfachkundige Person entstehen, erlischt jegliche Gewährleistungspflicht.

Versichern Sie sich, dass sich in diesen Bereichen weder Wasser- noch Elektroleitungen befinden und dass die mitgelieferten Befestigungsmaterialien für das Mauerwerk geeignet sind.  
Leichtbauwände o.ä. erfordern Spezialdübel, ansonsten ist die Lastaufnahme nicht ausreichend.

### **Achtung:**

Der Anschluss des Strom-Zuleitungskabels muss unter Berücksichtigung von VDE 0100 Teil 701 durch einen Fachmann erfolgen.  
Defekte Streu-/Schutzscheiben von Halogenstrahlern sind unbedingt zu ersetzen.

Änderungen aufgrund technischer Weiterentwicklung bleiben uns vorbehalten.

## F Instructions de montage

L'INSTALLATION DOIT ETRE REALISEE PAR UN PROFESSIONNEL.

«Tout montage incorrect est source de danger.

Si le mobilier est endommagé, si des personnes sont blessées suite à un mauvais montage, suite à une installation opérée par une personne non qualifiée, la garantie est automatiquement annulée.

Assurez-vous que sur la zone de montage l'eau et les lignes électriques soient absents, que les fixations fournies soient appropriées à la paroi de votre mur. Les murs de construction légère (avec ossature), etc. exigent des chevilles spéciales ; dans le cas contraire, la charge risque d'être insuffisante.

### **ATTENTION:**

Le raccordement du câble électrique doit être réalisé par un spécialiste en respectant la norme VDE 0100 partie 701. Une ampoule ou un disque de protection d'un halogène défectueux doit être absolument remplacé.

Toute modification relative au développement technique reste sous la responsabilité du producteur. »

## GB Installation instructions

INSTALLATION has to be made by a skilled and qualified person.

### **Warning:**

Incorrect assembly could be dangerous !

When damage to furniture or persons is caused by incorrect assembly or installation by non-qualified personnel, we will void any warranty.

Make sure that in the area of installation are no water nor electric lines and that the fixings provided are suitable for the wall.  
Stud walls, etc. require special plugs, otherwise the load is not sufficient.

### **ATTENTION:**

The connection of the power supply cable must be in accordance with VDE 0100 part 701 be done by a professional.

Defects protective glass of halogen lamps are to be replaced necessarily.

Changes due to technical improvements is reserved.



NL

## Montageinstructies:

Het Meubel moet gmonteered en geplaatst worden door een gekwalificeerd persoon.

Vorr montage het meubel nakijken of er geen zichtbare transportschade is.  
Klachten over schade worden niet aanvaard als het meubel gemonteerd is.

Verzerker u dat er geen waterleidingen of electrische leidingen achter het meubel lopen en dat het montagemateriaal en de muur geschikt zijn.

### OPGELET:

De electrische aansluiting moet uitgevoerd worden door een gekwalificeerde monteur.  
Defecte onderdelen of halogeen lampen moeten onmiddellijk vervangen worden.

Technische wijzigingen onder voorbehoud.

HR

## Uputstva za montažu

**MONTAŽU BI TREBALA PROVESTI STRUČNA OSOBA.**

Upozorava se na opasnost pri pogrešnoj montaži.

Oštećenja koja nastanu na namještaju ili osobama zbog nepravilne montaže ili zbog montaže provedene od strane nestručnih osoba poništavaju jamstvo.

Osigurajte da na tom području nema instalacija od vode i struje i da dostavljeni materijali za pričvršćivanje odgovaraju vrsti zida. Montažni zidovi ili slično zahtjevaju specijalne tiple, inače neće biti dovoljna čvrstoća montaže.

### Upozorenje:

Priključak kabla za dovod struje mora biti postavljen od strane stručne osobe po VDE 0100 dio 701.

Neispravne dijelovi na halogenim rasvjetama se moraju obavezno zamijeniti.

Zadržavamo pravo na promjene zbog daljnjeg tehničkog razvoja.

## Montage- und Pflegehinweise:

Sehr geehrter Kunde,  
wir gratulieren Ihnen zum Kauf unserer Badmöbel, die bei sachgemäßer Behandlung lange Freude bereiten werden.

Bitte beachten Sie folgendes:

- Verpackungsmaterial und Kleinteile außerhalb der Reichweite von Kindern aufbewahren.
- Möbel und Spiegel nur feucht wischen und nur milde Reinigungsmittel verwenden.
- Beachten Sie die Hinweise bei Microfasertüchern. Ungeeignete Microfasertücher können die Fronten stark beschädigen.
- Keine alkoholhaltigen, scheuernden oder scharfen Reinigungsmittel (Glasreiniger) einsetzen.
- Das Möbel immer trocken nachwischen, um eine Beschädigung des Materials (Aufquellen) oder der Spiegelbeschichtung (Blindflecken) durch stehendes Wasser zu verhindern.
- Benutzen Sie keine Dampfreiniger. Dies führt zu Quellungen und zerstört die Möbel.
- Alle Anschlußbereiche der Abdeckplatten zu anderen Schränken und Wandflächen, sowie zum Waschbecken, sind mit Silikon oder anderer geeigneter Dichtungsmasse zu versiegeln.
- Schützen Sie Ihre Möbel im Wannen/Duschbereich mit einer Duschabtrennung. Schäden, die durch übermäßige Nassbehandlung entstehen, sind von der Gewährleistung ausgenommen. Die Badmöbel sind für ein normales Badezimmerklima geeignet. Kurzfristige Luftfeuchtigkeit von 90 % mit eingeschlossen (kein Saunabetrieb).
- Mitgelieferte Haken und Dübel nur für Mauerwerk, Vollziegel MZ20, Hochlochziegel HLZ 20 oder Beton B25 geeignet.

**ACHTUNG: Vor der Montage ist das Produkt auf Transportbeschädigungen zu prüfen. Für Schäden an bereits montierten Produkten oder aufgrund einer unsachgemäßen Behandlung wird keine Haftung übernommen!**

### Hinweis bei Möbeln mit Elektro-Anschluss und Beleuchtung: Der Anschluss darf nur durch den Fachmann unter Beachtung der VDE 100, Teil 701 erfolgen!

Beim Auswechseln von Leuchtmitteln ist auf die Übereinstimmung der Angabe der max. Lampenleistung (W) und Spannung (V) mit den Daten des Transformators/Leuchte zu achten.

Eine beschädigte äußere Leitung darf nur durch eine Fachkraft ersetzt werden.

Eine defekte Trafobox kann nicht repariert werden und ist gegen eine neue auszutauschen.

Vor dem Lampenwechsel Stromversorgung unterbrechen.



Bei einer festen Installation muss der Versorgungsstromkreis mit einer Trennvorrichtung (z.B. Schalter) ausgestattet sein.



Lampe bei der Anwendung vor Feuchtigkeit schützen!



Mindestabstand zu angestrahlten Flächen, z.B. 10 cm



Schutzisoliert, Schutzklasse I, Geräte mit Schutzleiteranschluss (gelb/grün)



Zur Direktmontage auf oder an schwer oder normal entflammaren Baustoffen.



Zum Einbau in Möbel geeignet, jedoch nicht bei normal entflammaren Oberflächen.



Diese Leuchte ist nicht für die Verwendung mit "Kaltlicht - Lampen" (Cool beam Lamp) geeignet.



Die durchschnittliche Lebensdauer unserer LEDs beträgt 15.000 Stunden. Nach der genannten Lebensdauer beträgt die Lichtleistung circa 70% der Ausgangslichtleistung.



Vermeiden Sie längeren direkten Blickkontakt mit der LED-Lichtquelle, da sonst Schaden am Auge entstehen könnte.



Bei Halogenleuchte: Lampenkolben nur mit einem Tuch anfassen und in die Fassung einsetzen!



Bei Halogenleuchte: Kolben wird sehr heiß (bis 350 °C), vor dem Auswechseln oder Einstellen der Leuchte das Leuchtmittel abkühlen lassen!



Bei Halogenleuchte mit Schutzglas: Jedes zerbrochene Schutzglas ist sofort gegen ein neues auszutauschen!



Halogen-Glühlampen, die den erforderlichen Schutz gegen Platzen aufweisen.

## Instructions for mounting and use:

Dear customer,  
Congratulations for purchasing our bathroom furniture, which will provide you with long-lasting pleasure, if you will follow our instructions for cleaning and maintenance:

- Keep the packaging material and small parts out of the reach of children.
- Please polish the furniture and the mirror with a moist cloth, only use mild detergents.
- Please mind the instructions of microfibre cloths. Unsuitable microfibre cloths can do severe damage to the fronts.
- No alcoholic, scratching or aggressive cleansing agents (glass detergents).
- Please wipe the furniture always with a dry cloth to avoid any damages to the material (swelling) or of the mirror surface (blind stains) because of remaining water.
- Do not use steam cleaner. The use of steam cleaners leads to swelling of the wood and ruins the furniture.
- All fittings of the basin plate in contact with other cupboards and walls or to the base itself have to be sealed with silicone or other appropriate sealing materials.
- Protect your furniture – if in contact to shower or tub – by a shower severance.
- Please note that we cannot accept any complaints regarding damages of extraordinary effects by water or humidity. Our bathroom furniture is meant for use at regular bathrooms conditions, including shorttime air humidity of 90 % (no sauna).
- The included hooks and dowels are only suitable for walls of masonry, bricks MZ20 hole bricks HLZ20 or concrete B25.

**ATTENTION ! Before mounting please check the product to see if any damage has been caused during transportation. Please note that we cannot accept any complaints regarding damage after the product has been mounted.**

**Information for furniture with electrical connection and lighting: The electrical device must be connected by a qualified electrician in compliance with VDE 100, Part 701!**

When changing bulbs, make sure that the maximum wattage (W) and the voltage (V) of the replacement bulb conform to the transformer or lamp.

A outer cable must be replaced only by a specialist.  
The trafo-box cannot be repaired and must be replaced.



Disconnect the power supply before changing bulbs. In case of a fixed installation the electrical connection has to be equipped with a separating appliance (f.ex. switch)



Protect lamp from moisture or wetness during



Minimum distance to the illuminated surface f.ex. 10 cm



Protected isolation, protection class I, appliance with protected connection (yellow/green)



For direct installation on heavy or normal infammable materials.



Suitable for installation in furniture, but not on normal inflammable surfaces.



This lamp is not suitable for cool beam lamps.



The average life time of our LEDs is 15,000 hours. The optical power is around 70% of the exit optical power after the mentioned life time.



Avoid a longer direct visual contact with the LED light source since otherwise damage to the eye could arise.



For halogen lamps: Always use a cloth when handling bulb or inserting into the socket!



For halogen lamps: bulb becomes extremely hot (up to 350 ° C), before changing the bulb or adjustment of the lamp allow to cool down the bulb !



For halogen lamps with protective glass: A broken protective glass must be replaced immediately!



Halogene bulb with protection against bursting.

## Montage- en Onderhoud advies:

Wij feliciteren u met de aankoop van ons badkamermeubel welke U, bij goed onderhoud, vele jaren van gebruiksplezier zal bieden. Gelieve volgende tips in acht te nemen:

- Bewaar het verpakkingsmateriaal en kleine onderdelen buiten het bereik van kinderen.
- Het meubel en spiegel enkel met vochtige doek en milde reinigingsmiddelen schoonmaken.
- Bij gebruik van micro-vezel doeken gelieve de gebruiksaanwijzing te respecteren. Onooglijk gebruik kan tot sterke beschadiging van de fronten leiden.
- Geen alcoholhoudende of schurende of agressieve schoonmaakmiddelen (glasreinigers) gebruiken.
- Het meubel altijd droog napoetsen om beschadiging door opzwellen van het materiaal of aantasting van de spiegel laag veroorzaakt door vocht/staand water te vermijden.
- Geen stoom/damp reinigers gebruiken. Dit leidt tot mogelijke opzwellen en beschadigt het meubel.
- Alle naden tussen de meubelen en/of wastafel en afdekplaten moeten met een daarvoor geschikt afdichtmiddel afgewerkt worden.
- Bescherm Uw meubel voor spatwater door middel van een douche afscheiding. Schade door overmatig vocht en water wordt niet aanvaard.
- De badmeubelen zijn geschikt voor een normaal badkamerklimaat. Kortstondige vochtigheidsgraad van 90% inbegrepen. (Geen sauna omgeving)
- Bijgeleverde haken en pluggen zijn enkel geschikt voor normaal metselwerk met volle steen (MZ20 of HLZ 20) en beton (B25).

**Voor montage alle onderdelen op eventuele transportschade controleren. Schade aan reeds gemonteerde meubelen of door onoordeelkundige manipulatie kan geen rede tot klacht zijn. Gebruiksaanwijzing bijmeubelen met electro-aansluiting en verlichting.**

**De elektrische aansluiting moet uitgevoerd worden door een erkend vakman conform de VDE 100 deel 701 normen!**

Bij uitwisseling van lampen moet rekening gehouden worden met de aangegeven max. Watt en spanning (V) aangegeven op de transfo/verlichting.

Een beschadigde buitenleiding mag enkel door een vakman vervangen worden  
Een defecte transformator kan niet gerepareerd worden maar enkel vervangen.



Voor uitwisseling lampen stroom onderbreken.  
Bij definitieve installatie moet de stroomaansluiting voorzien zijn van schakelaar.



Lampen bij gebruik tegen vocht beschermen!



Minimale afstand tot aangestraalde oppervlak (bijv. 10 cm)



Beveiligde isolatie, beveiliging klasse I, toestel met aarding (geel-groen)



Voor rechtstreekse montage op moeilijk of niet ontvlambare materialen

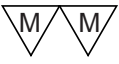

Geschikt voor inbouw, echter niet bij normaal ontvlambare oppervlakken.



Deze lamp is niet geschikt voor "koude straal lampen"



De gemiddelde levensduur van onze LED is 15.000 uur. De licht prestatie bedraagt na deze duur circa 70% van de oorspronkelijke lichtsterkte.



Vermijd langdurig direct oogcontact met de LED-lichtbron, anders kan schade aan de ogen veroorzaken.



halogeenlampen: lamp enkel met doek vastnemen en in fitting plaatsen!



Voor Halogeen lampen: De kolf wordt zeer heet (tot 350° C), Voor aanpassing van de kolf van de lamp of de richting de verlichting laten afkoelen!



Bij halogeenlampen met beschermglas: Elk gebroken beschermglas onmiddellijk vervangen!



Halogeen gloeilampen met bescherming tegen kapot springen

## Instructions de montage et d'utilisation : Instructions de montage et d'utilisation :

Chère cliente, Cher client,

Félicitations pour l'achat du meuble de salle de bains, qui vous satisfera pleinement, tant que nos instructions de nettoyage et d'entretien seront respectées.

- Gardez les matériaux d'emballage et les petites pièces hors de portée des enfants.
- Veuillez polir le meuble et le miroir avec un chiffon humide, utilisez uniquement des détergents doux.
- Observer les instructions des chiffons de microfibre. Les chiffons de microfibre inappropriés peuvent endommager les fronts gravement.
- N'utilisez aucun produit abrasif ou à base d'alcool, des détergents puissants (tels les nettoyeurs pour vitres).
- En cas de stagnation de l'eau, veuillez toujours essuyer le meuble et le miroir avec un chiffon sec pour éviter tout dommage (gonflement sur la surface, tâches aveugles sur le miroir).
- Ne pas utiliser du nettoyeur à vapeur. L'usage d'un nettoyeur à vapeur fait gonfler le bois et détruit les meubles. Tous les raccords entre et sur le plan de travail, le mur, d'autres armoires ou le lavabo doivent être réalisés en silicone ou dans d'autres matériaux d'étanchéité appropriés.
- Prévoyez une certaine distance entre vos meubles et l'espace douche ou la baignoire.
- Nous n'accepterons aucune réclamation relative à des dommages inhabituels causés par l'eau ou l'humidité.
- Nos meubles sont destinés à être installés dans une salle de bains, dont le taux d'humidité dans l'air peut être de 90% pendant un court instant (ne pas créer un environnement sauna).
- Les crochets et les chevilles inclus avec le meuble conviennent uniquement aux murs en mortier/pierre/brique (briques MZ20 ou briques creuses HLZ20) et en béton B25.

**ATTENTION : avant de monter le meuble, veuillez, s'il vous plaît, vérifier s'il a subi ou non des dommages durant le transport. Nous n'accepterons aucune plainte relative à des dommages causés durant / après montage, ou suite à un traitement inadéquat.**

### INSTALLATION ELECTRIQUE ET BRANCHEMENTS:

**Les raccordements électriques doivent être réalisés par un professionnel selon les normes en vigueur.**

En cas de changement de luminaires, veuillez respecter la puissance maximale en Watts et Volt indiquée sur les ampoules.

Un câble extérieur ne doit être remplacé que par un spécialiste.

Un câble transformateur / interrupteur ne peut pas être réparé mais doit être remplacé



Couper le courant avant toute manipulation. Pour sécuriser votre installation, l'alimentation électrique doit être assurée par un dispositif de séparation (un commutateur, un interrupteur par exemples).



Eviter toute projection d'eau vers les ampoules.



Distance minimale par rapport à la surface illuminée p.ex. 10 cm.



Protection isolante, protection de classe I, appareils avec connexion en conducteur de protection (jaune / vert).



Peut être monté directement sur des matériaux de construction lourds ou normalement inflammables.



Convient au montage de meubles, mais ne pas monter sur une surface inflammable.



Cette lumière n'est pas adaptée pour être utilisée avec « une ampoule à lumière froide » (Cool beam lamp).



La durée de vie moyenne de nos LED est de 15000 heures. Au-delà de la durée de vie mentionnée, la diffusion de la lumière est d'environ 70 % de sa performance.



Evitez un contact direct et prolongé avec la source lumineuse LED, car cela endommagerait gravement vos yeux.



Halogène : saisir l'ampoule avec un tissu avant de l'installer.



Pour une lampe halogène : si l'ampoule halogène est très chaude (jusqu'à 350° C), avant de la changer ou l'ajuster, laissez la complètement refroidir !



Halogène avec écran de protection : remplacer sans tarder tout écran de protection fissuré.



Ampoule halogène avec protection nécessaire contre l'éclatement.

## Montaža i način održavanja:

Poštovani,

želimo Vam čestitati na kupnji kupaonskog namještaja s kojim ćete pri pravilnim rukovanjem biti dugoročno zadovoljni.

Molimo obratite pažnju na slijedeće:

- Ambalažu i sitne dijelove držite izvan dohvata djece
- Namještaj i ogledalo čistite samo vlažnom krpom i samo s blagim deterdžentom.
- Molimo pročitajte obavijesti na krpi od mikrovlakana. Neprikladna krpa od mikrovlakana može oštetiti prednje dijelove ormara.
- Molimo nemojte koristiti alkoholna sredstva za čišćenje, abrazivna sredstva ili jake deterdžente (sredstva za čišćenje stakla)
- Namještaj uvijek prebrišite kako bi se spriječilo oštećenje materijala ( naticanje) ili sloj ogledala (slijepe pjege) prilikom stajanja vode na ogledalu.
- Nemojte koristiti parni čistač. To dovodi do bubrenja i uništenja namještaja.
- Sve spojeve pokrovnih ploča prema drugim ormarima i zidovima kao i prema umivaoniku treba zaštititi silikonom.
- Zaštitite Vaš namještaj sa pregradom u prostorima s kadom / tušem. Oštećenja koja nastanu prekomjernim vlaženjem isključeni su iz jamstva.
- Namještaj je namijenjen za kupaonice s normalnom kupaonskom klimom. Kratkotrajna vlažnost zraka od 90% je uključena ( bez saune)
- Isporučene kukice i tiple su prikladne za zidove, puna opeka MZ20, blok opeka HLZ 20 ili beton B22.

**UPOZORENJE: Prije postavljanja proizvoda treba provjeriti postoje li oštećenja nastala pri transportu. Ne preuzimamo odgovornost za oštećenja nastala prilikom montiranja ili nestručnog rukovanja!**

**Napomena za namještaj sa električnim priključkom i rasvjetom: Priključak smije biti proveden od strane kvalificiranog električara u skladu sa VDE 100, dio 701!**

Prilikom zamjene rasvjetnih tijela potrebno je obratiti pažnju da je najviša dopuštena snaga (W) i napon (V) žarulje usklađen sa podacima na transformatoru rasvjete.

Vanjsko oštećenje kabla smije biti zamijenjeno samo od strane stručne osobe.

Neispravna trafo kutija se ne može popraviti nego mora biti zamijenjena novom.



Prije zamjene žarulje prekinuti dovod struje.

Pri fiksnoj instalaciji električna veza mora biti opremljena separatorom (npr. prekidačem).



Pri korištenju svjetiljku zaštitite od vlage!



Najmanj odstojanje od površine koje se osvjetljuje, npr. 10cm.



Zaštićena izolacija, razred zaštite II, uređaji bez priključka zaštitnog vodiča (žuto/zeleno).



Za izravnu montažu na teško ili normalno zapaljivim materijalima.



Prikladan za ugradnju u namještaj, ali ne kod normalno zapaljivih površina.



Ova svjetiljka nije prikladna za korištenje žarulja sa "hladnim svjetlom"



Prosječan vijek trajanja naše LED žarulje je 15.000 sati. Nakon navedenoga vijeka jakost svjetla je 70% od početnog.



Izbjegavajte dulji izravan kontakt sa LED izvorom svjetlosti, u protivnom može uzrokovati oštećenja na vidu.



Kod halogenih svjetiljki: žarulju primiti krpom i umetnuti!



Kod halogenih svjetiljki : žarulja postaje jako vruća (do 350°C) te prilikom zamjene ili ugradnje treba ju pustiti da se ohladi!



Kod halogenih svjetiljki sa zaštitnim staklom: razbijeno zaštitno staklo odmah zmiijeniti novim!



Halogene lampe koje imaju zaštitu od pucanja.





**ACHTUNG  
HOHE BRUCHGEFAHR!**

Liebe Kundin, lieber Kunde!

Für einen eventuellen Versand verpacken Sie den Artikel bitte genauso wie Sie ihn erhalten haben. Verwenden Sie die Originalverpackung mit Füll- und Polstermaterial, da wir Ihnen sonst eventuell auftretende Transportschäden belasten müssen!



**ATTENTION  
High risk of breaking**



Dear customer!

If the article is to be shipped, please pack IT In exactly the same fashion as when you received it. Use the original packing with filling and padding material. as otherwise we would have to Charge you for any damage occurring in transit!



**ATTENTION  
Danger de casse - très fragile!**



Chère cliente, Cher client!

Pour un transport eventuel, veuillez emballer l'article avec les mêmes précautions que celles prises pour son expedition initiale. Utiliser l'emballage original avec la matière ae doublure et de remplissage; sinon, des dommages de transport éventuels seront portés à votre charge!



**UWAGA!  
Niebezpieczeństwo stłuczenia!**



Szanowny Kliencie!

W przypadku konieczności odesłania artykułu do naszej firmy, prosimy zapakować artykuł w taki sam sposób, w jakim został on do Państwa dostarczony. W tym celu prosimy o używanie osłon i wypełnień jakie zawierały oryginalne opakowania. W razie wystąpienia szkód powstałych w transporcie, będziemy zmuszeni obciążyć Państwa kosztami ich usunięcia.



**OPREZ  
VISOKI RIZIK OD LOMA!**



Poštovani!

U slučaju transporta, molimo zapakirajte artikl točno kako ste ga i primili. Koristite izvornu ambalažu s punjenjem i materijalom za zatrpavanje, inače ćemo Vas za eventualna oštećenja prilikom transporta morati teretiti.

