

- | | | | |
|----------|--------------|-----------------------|------------------------|
| 1 | 8x
Nr.98 | 2x
Nr.367 | 4x
Nr.502 |
| | 1x
Nr.144 | 1x
Nr.143 | 2x
6,3x13
Nr.274 |
| 2 | 8x
Nr.76 | 16x
Ø8x30
Nr.80 | |

Service-Hotline
01805-678101
0,14€ pro Minute
++49 für Österreich
Auslandstarif pro Minute
service@jaka-bkl.de
voor Nederland en België
00800-40119350
benelux@jaka-bkl.de

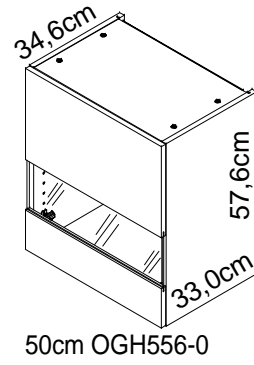

Montageanleitung

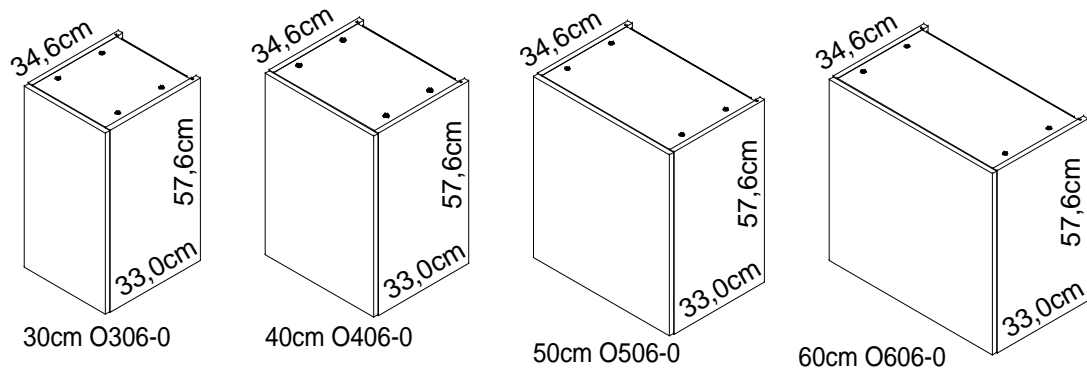
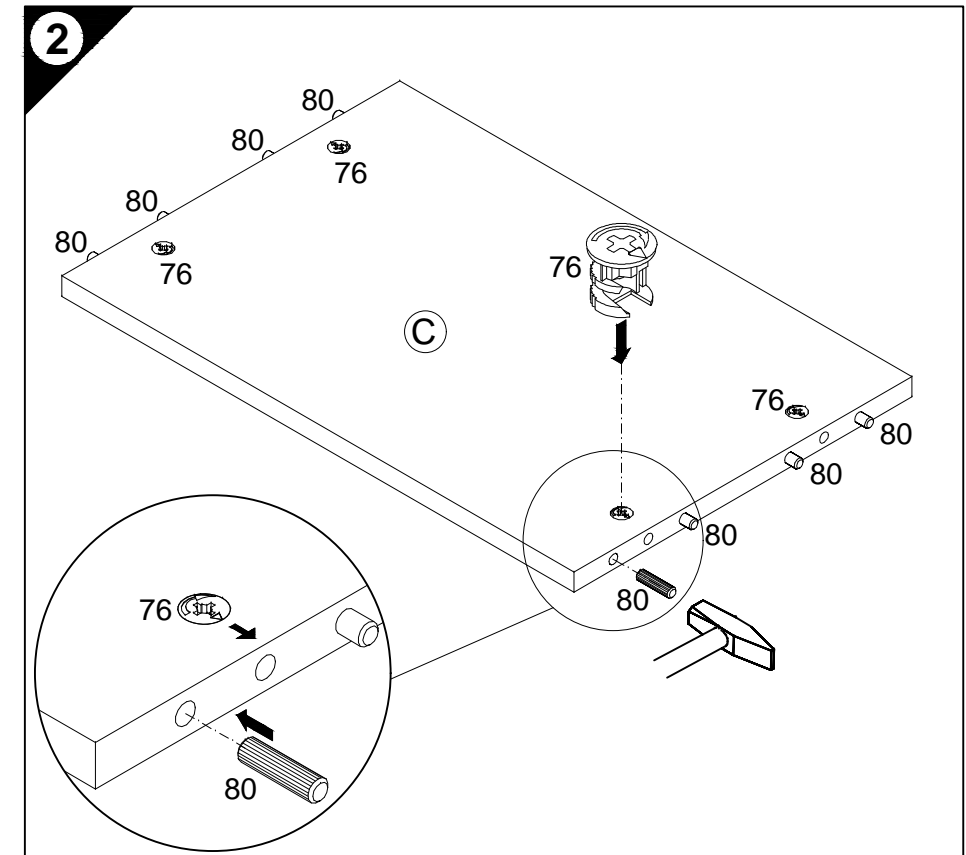
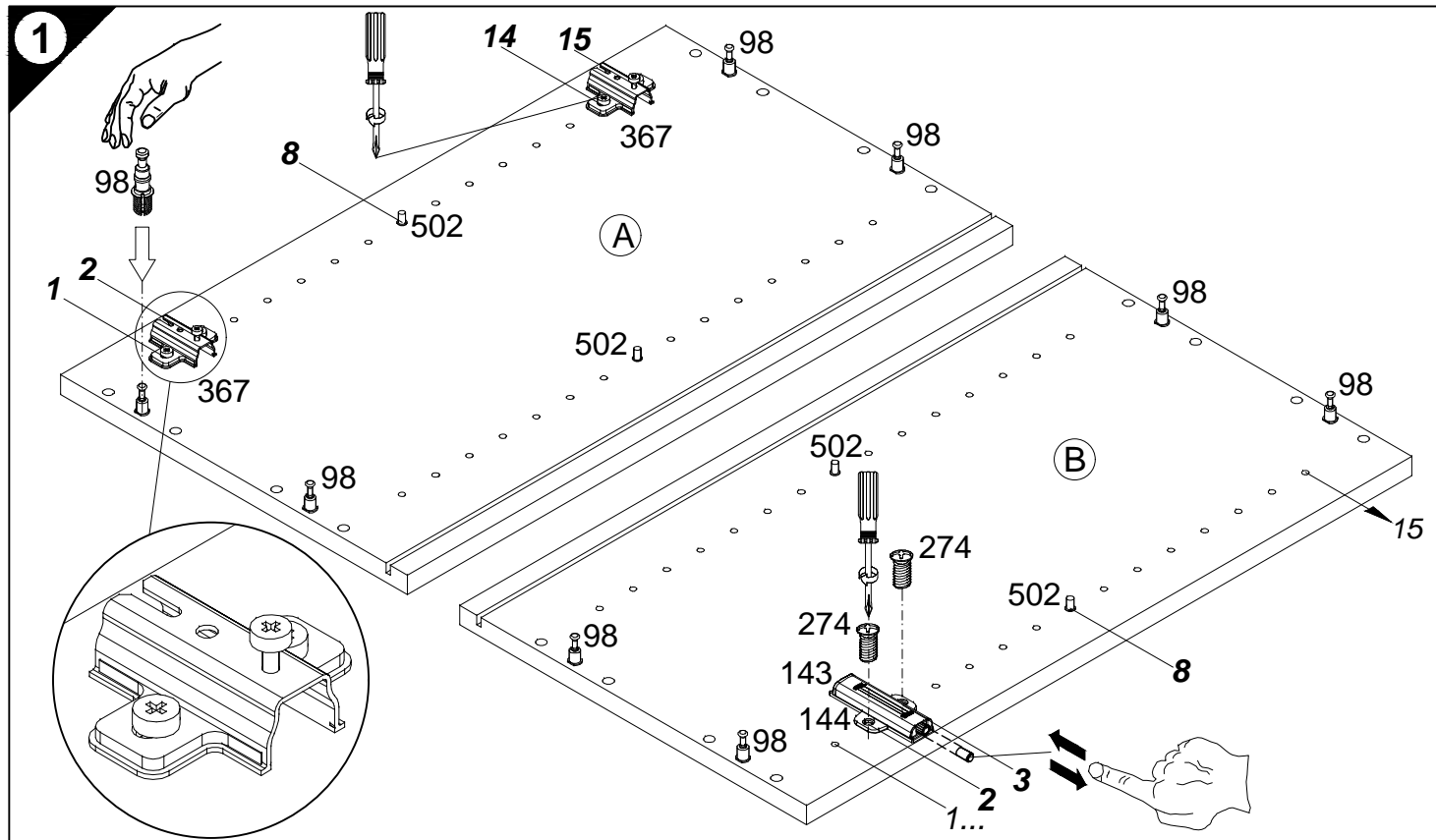
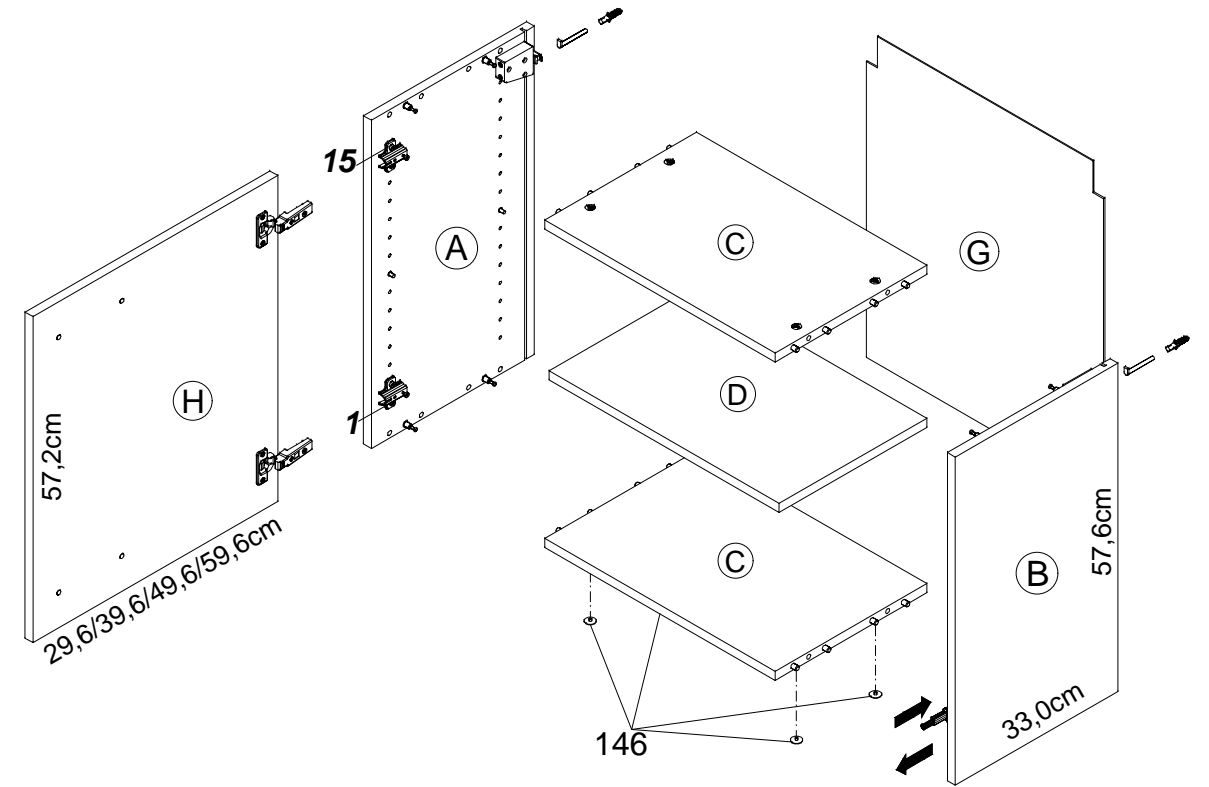

Ersatzteile/Spare parts/pièces de rechange/Reserveonderdelen/Piezas de recambio/Ricambi/Запасные части/Części zamienne/pótkatrészek/Náhradní části/Nadomestni deli/varaosat/reservdelar/náhradné diely/Utilizați piese de schimb/Yedek parçalar

30cm O306-0	(A) E940036	(B) E940036	(C) E941236	(D) E940336	(G) E971015	(H) E940614
40cm O406-0	(A) E940036	(B) E940036	(C) E941235	(D) E940335	(G) E971014	(H) E940613
50cm O506-0	(A) E940036	(B) E940036	(C) E941234	(D) E940334	(G) E970032	(H) E940612
50cm OGH556-0	(A) E940036	(B) E940036	(C) E941234	(D) E940334	(G) E970032	(H) E940655
60cm O606-0	(A) E940036	(B) E940036	(C) E941233	(D) E940333	(G) E971012	(H) E940611

1 → 2 → 3 ...

- 3 4x
Ø18/Ø4
Nr.146
- 4 2x
Nr.277
- 6x
4x30
Nr.164
- 5 10x
Nr.204
- 7 2x
Nr.365
- 4x / 2x
Ø4,9/Ø7,5
Nr.102
- 2x OGH556
Nr.107
- 9 2x
Ø8x40
Nr.70
- 2x
Nr.69
- 10 2x
4x30
Nr.424

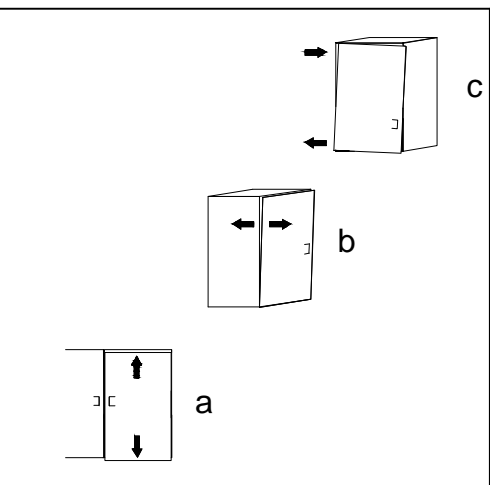
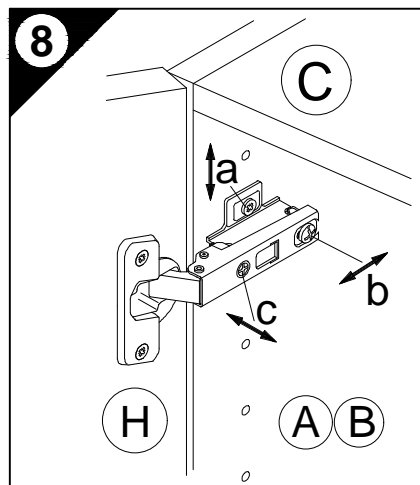
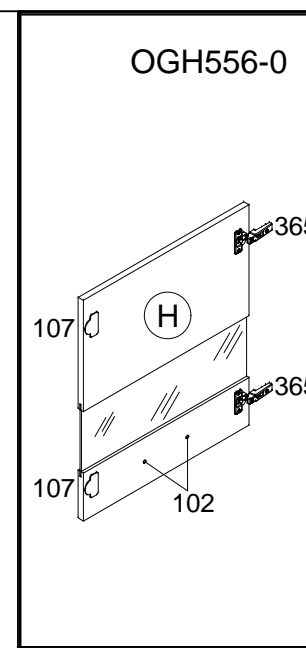
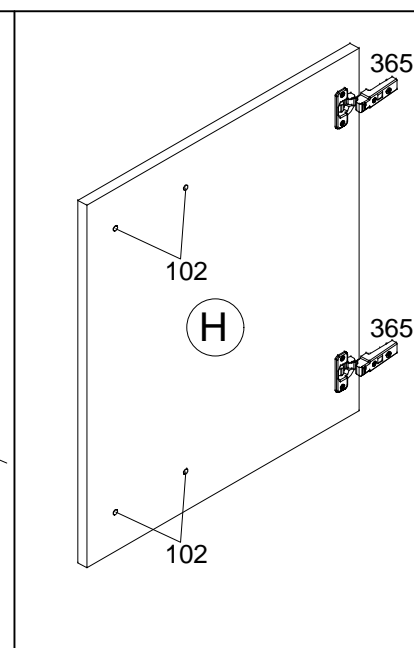
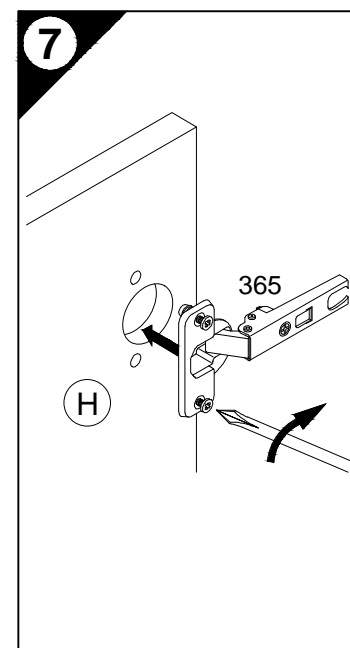
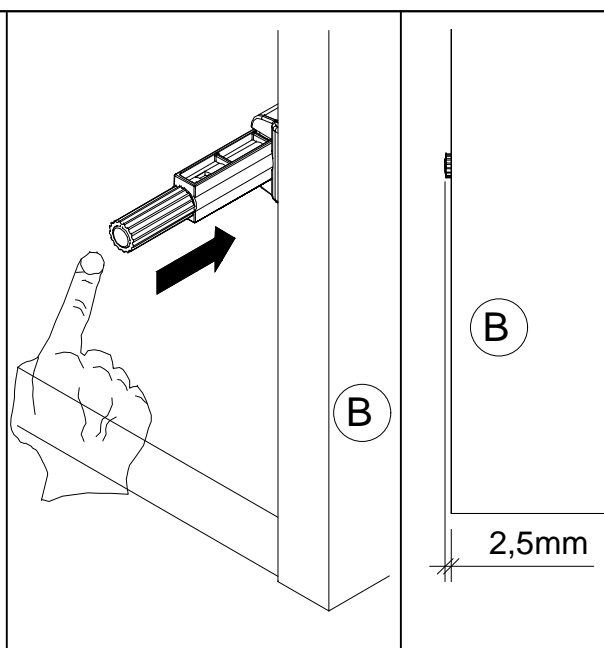
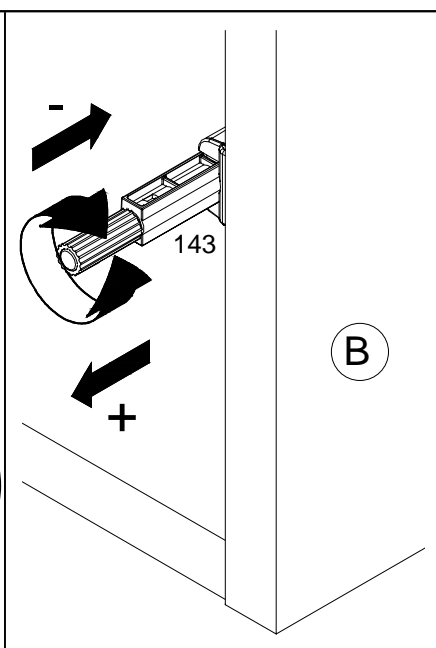
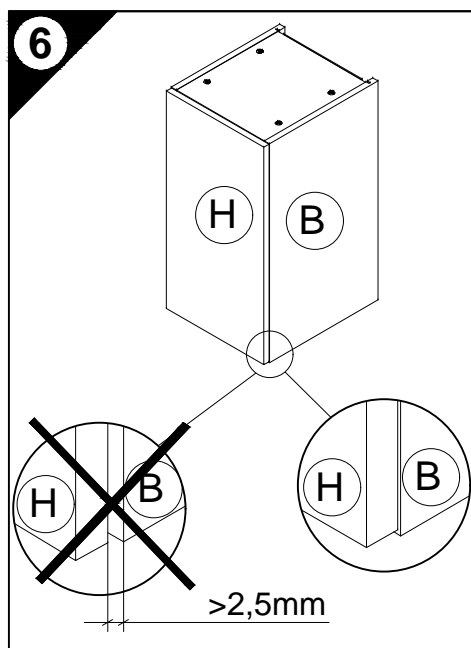
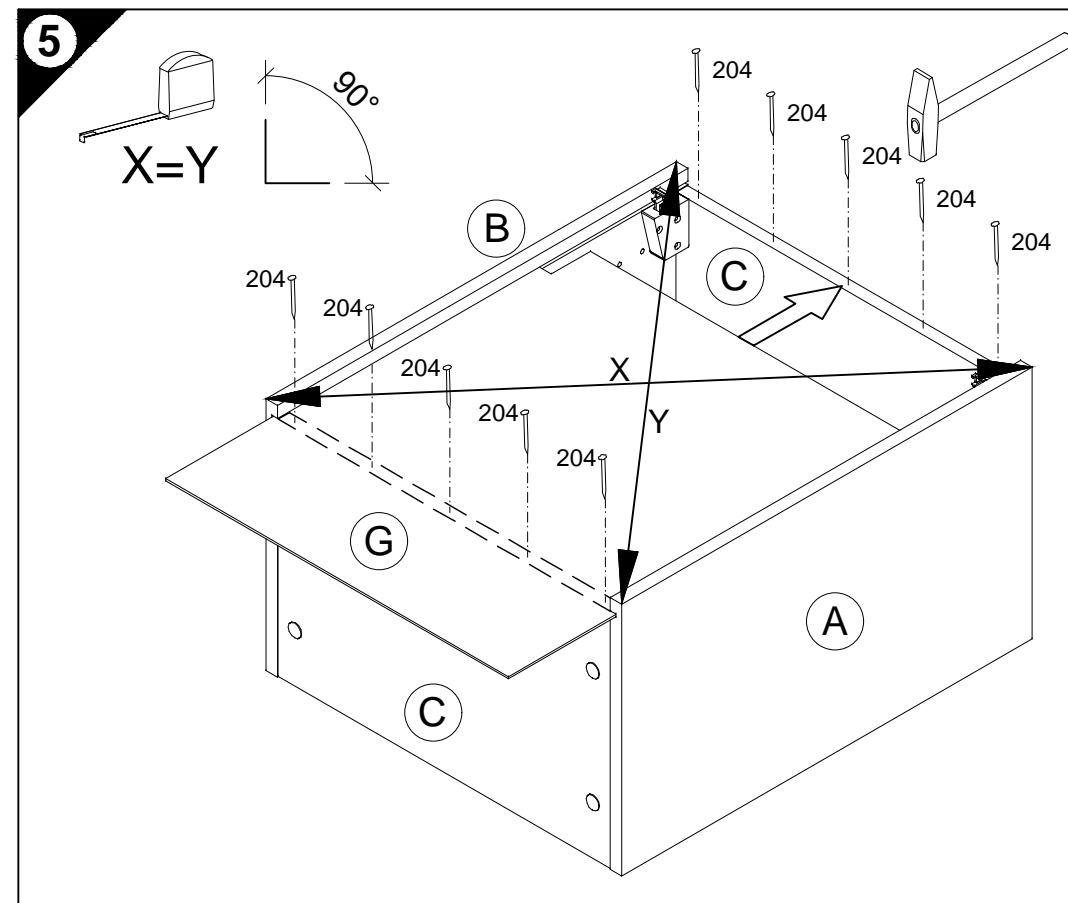
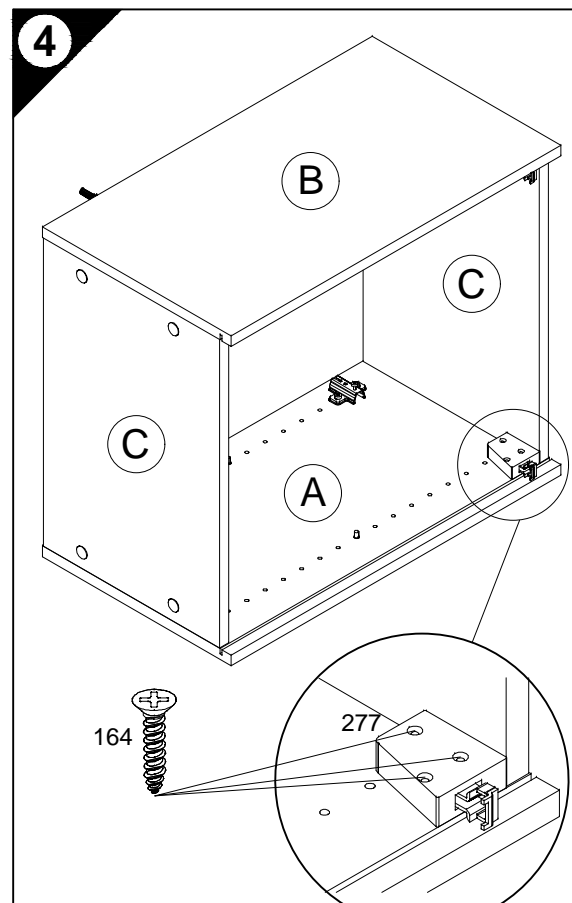
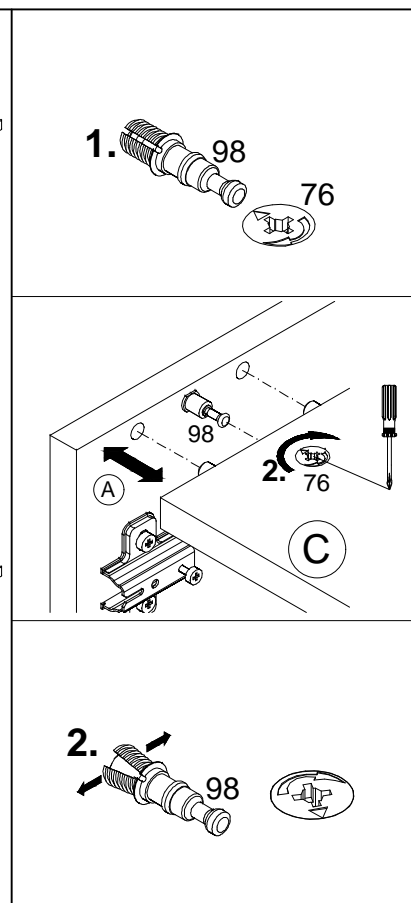
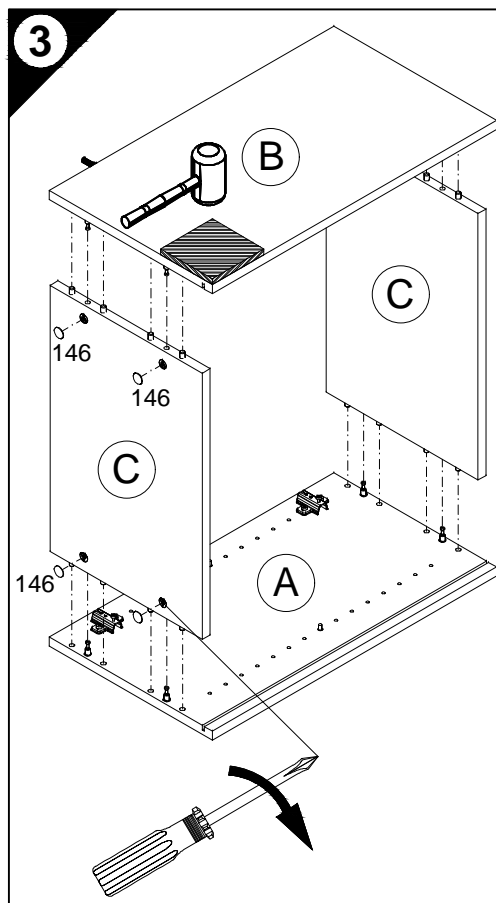

9

D Untergrund und Befestigungsmittel auf Eignung prüfen!
 GB Check substructure and fixings for suitability!
 F Contrôler si le support et les moyens de fixation sont bien adéquats !
 NL Ondergrond en bevestigingsmateriaal op functionaliteit controleren!
 E ¡Comprobar el suelo y los medios de fijación en cuanto a su aptitud!
 I Controllare l'idoneità del fondo e del materiale di fissaggio!
 RUS Основание и крепежный материал проверить на пригодность!
 PL Podłoże oraz materiały do zamocowania sprawdzić na ich przydatność!
 H Az alapelületet és a rögzítő anyagokat megfelelőség szempontjából ellenőrizni kell!
 CZ Přezkoušejte podklad a vhodnost upevňovacích prostředků!
 SLO Preverite, če se ujemajo spodnja stran in pritrilna sredstva!
 FIN Tarkista alustan ja kiinnitysvälineiden sopivuus!
 S Kontrollera att underlaget och fästmedlen är lämpliga!
 SK Preverte vhodnosť podkladu a upevňovacích prostriedkov!
 RO Verificați caracterul adecvat al suprafeței suport și al mijloacelor de fixare!
 TR Zeminin ve bağlantı elemanlarının uygunluğunu kontrol edin!

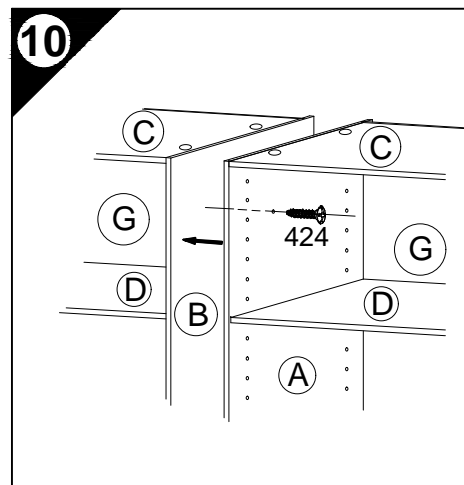
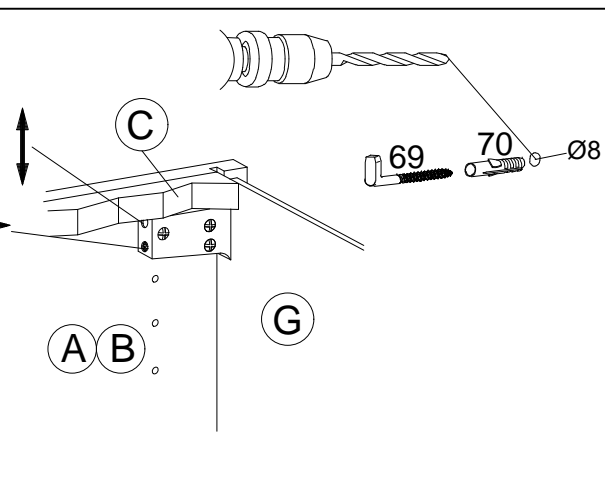

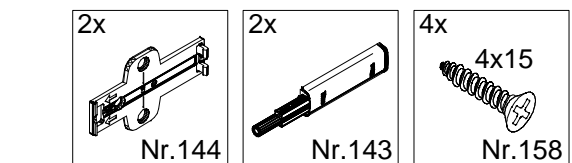
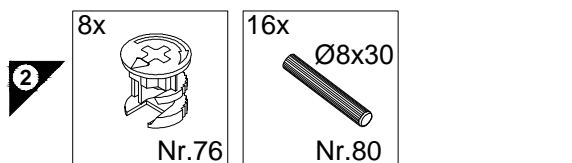
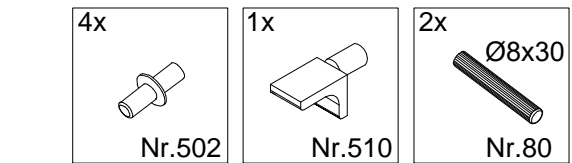
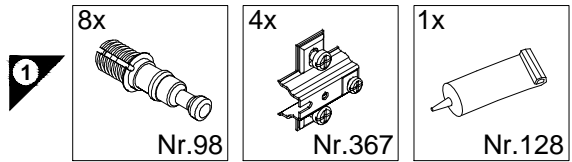
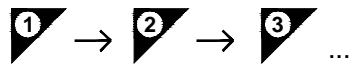
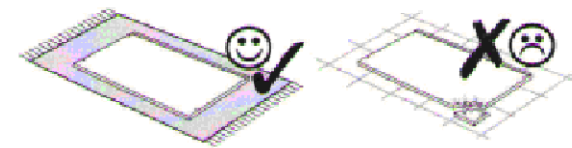
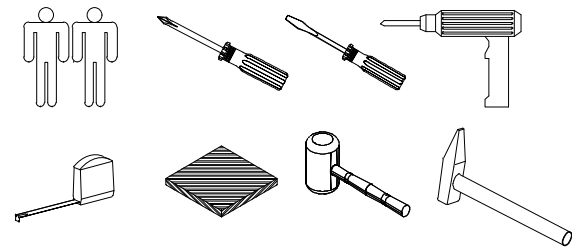

Service-Hotline
01805-678101
0,14€ pro Minute
+49 für Österreich
Auslandstarif pro Minute
service@jaka-bkl.de
voor Nederland en België
00800-40119350
benelux@jaka-bkl.de

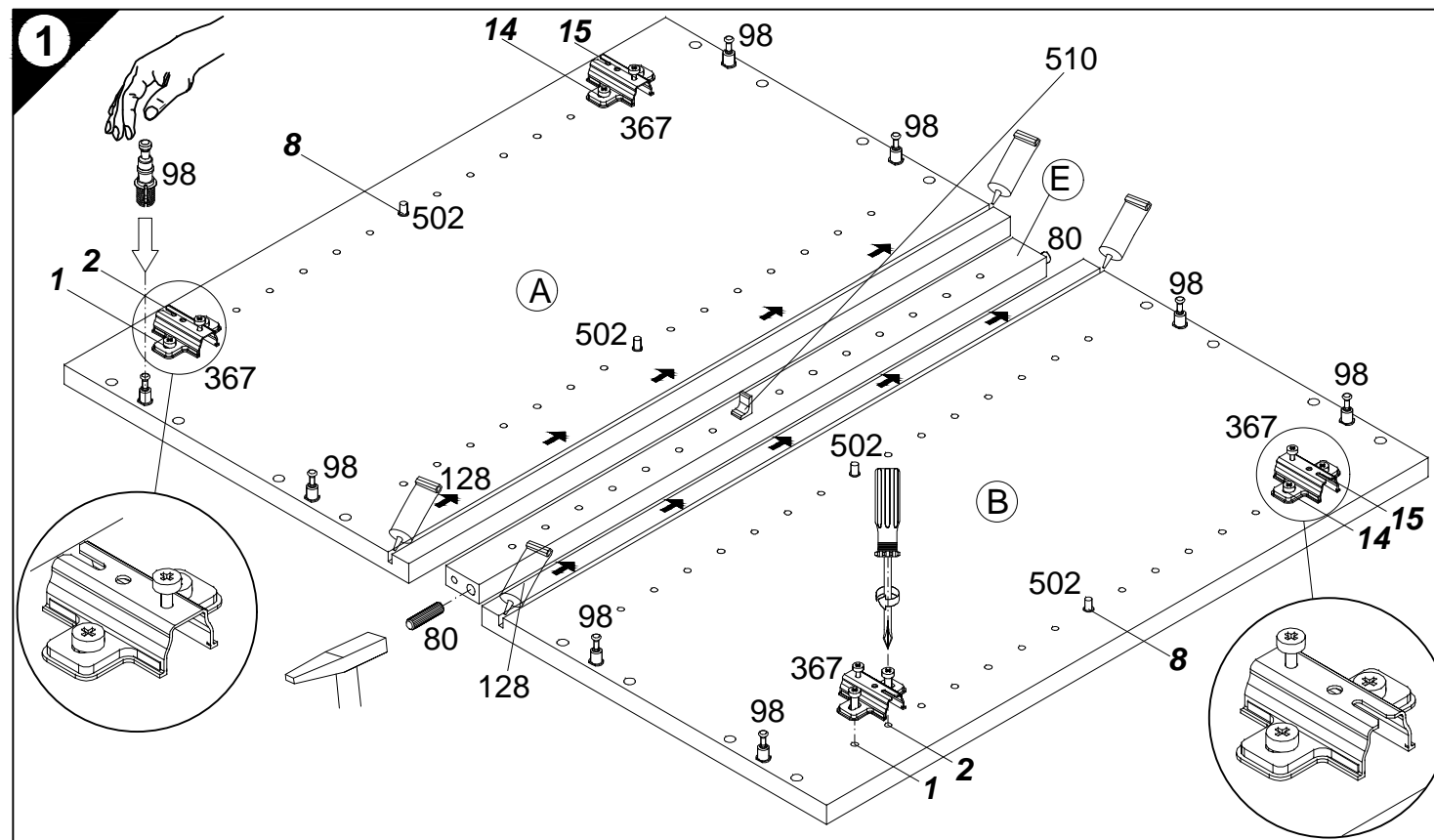
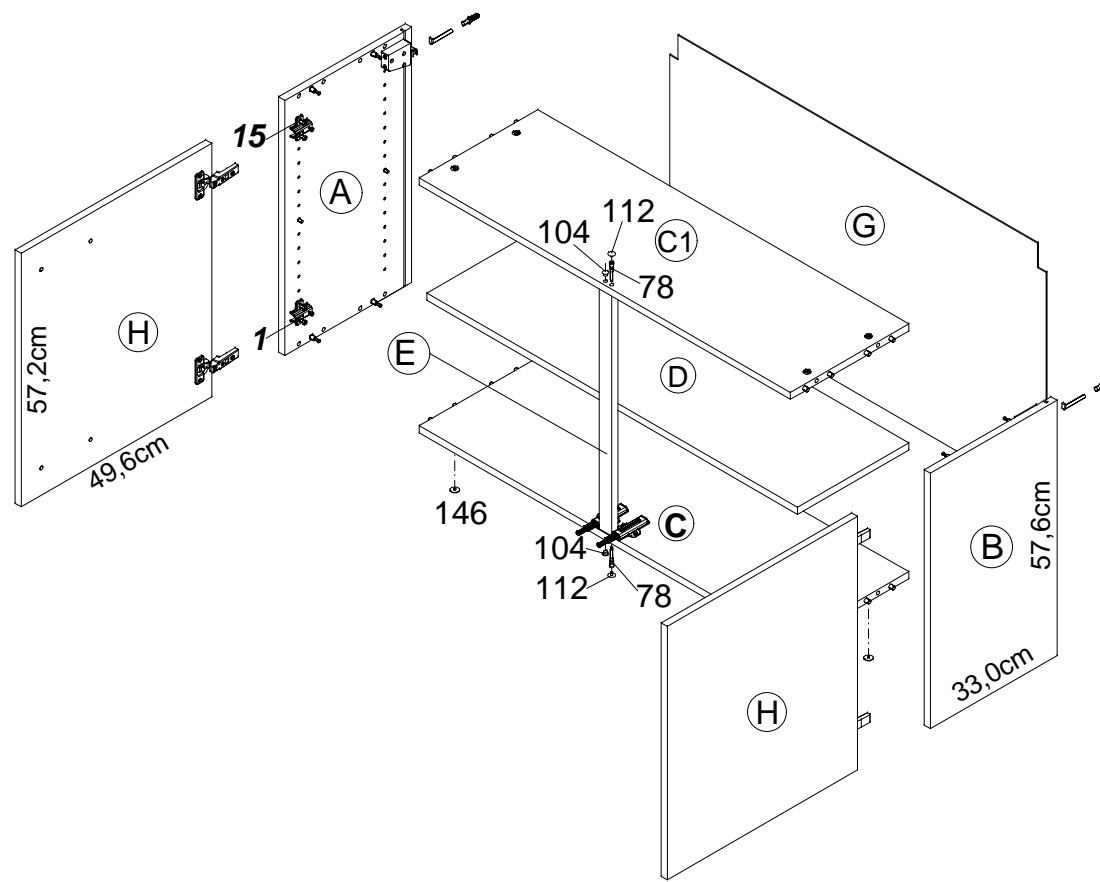
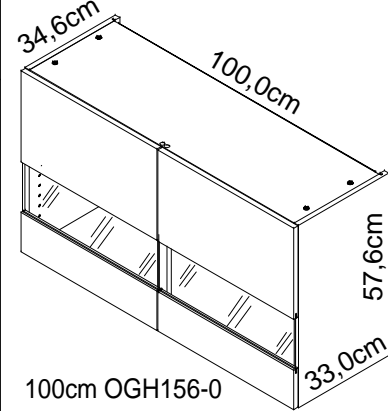
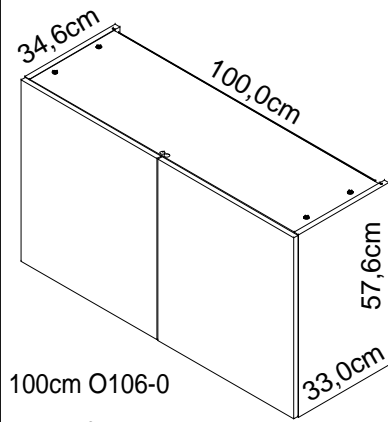

Montageanleitung

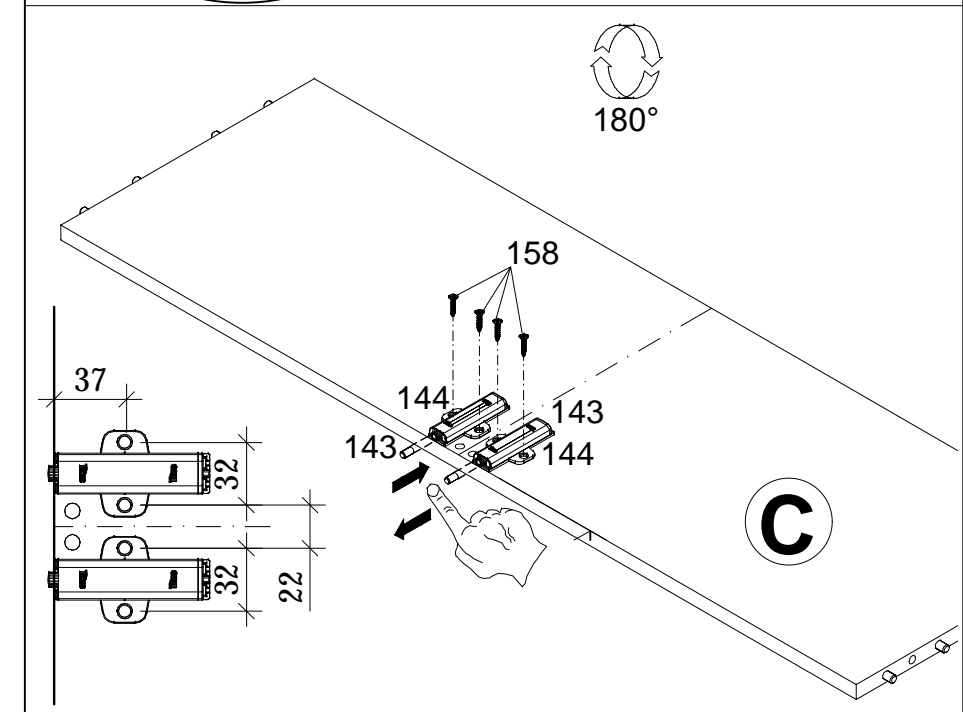
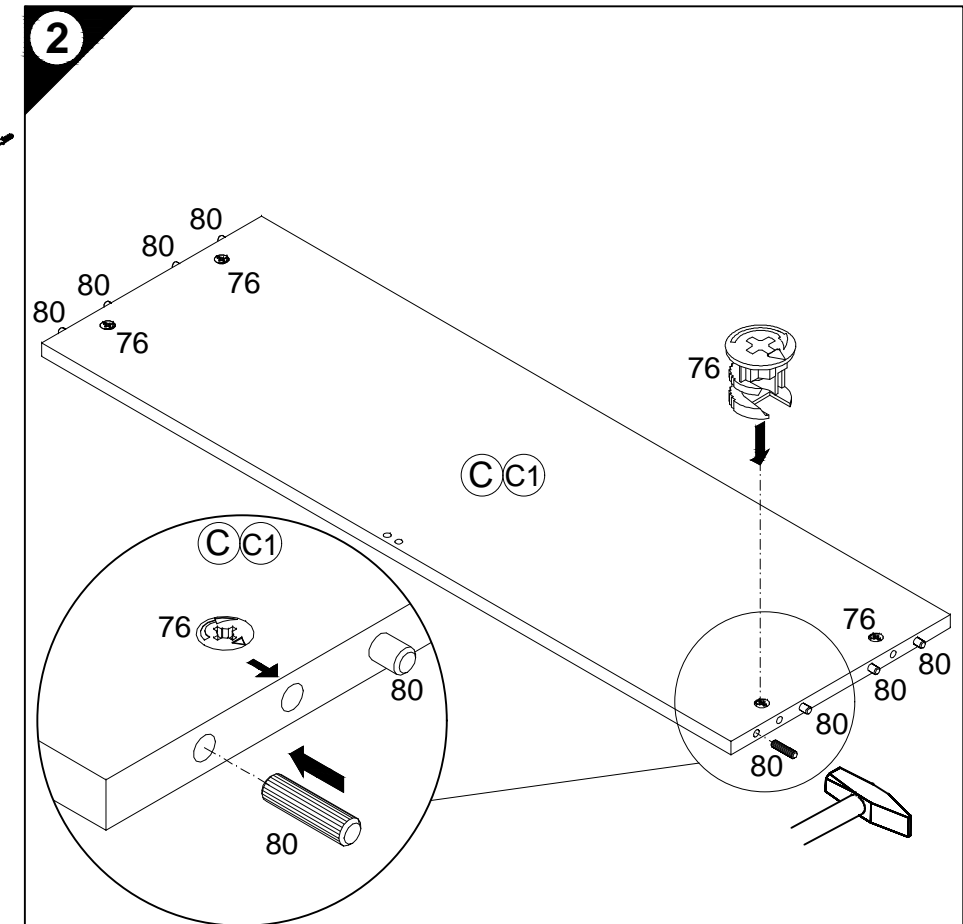

Ersatzteile/Spare parts/pièces de rechange/Reserveonderdelen/Piezas de recambio/Ricambi/Запасные части/Części zamienne/pótalkatrészek/Náhradní části/Nadomestni deli/varaosat/reservdelar/náhradné diely/Utilizați piese de schimb/Yedek parçalar

100cm O106-0 | (A) E940036 (B) E940036 (C) E942231 (C1) E942231 (D) E941331 (E) E940100 (G) E971026 (H) E940612
100cm OGH156-0 | (A) E940036 (B) E940036 (C) E942231 (C1) E942231 (D) E941331 (E) E940100 (G) E971026 (H) E940655

1 → 2 → 3 ...

- 3x 4x Ø18/Ø4 Nr.146
- 2x Ø8/Ø13 Nr.104
- 2x 7x42 Nr.78
- 2x Ø3/Ø15 Nr.112
- 2x Nr.277
- 6x 4x30 Nr.164
- 16x Nr.204
- 4x Nr.365
- 8x / 4x Ø4,9/Ø7,5 Nr.102
- 4x OGH156 Nr.107
- 2x Ø8x40 Nr.70
- 2x Nr.69
- 2x 4x30 Nr.424

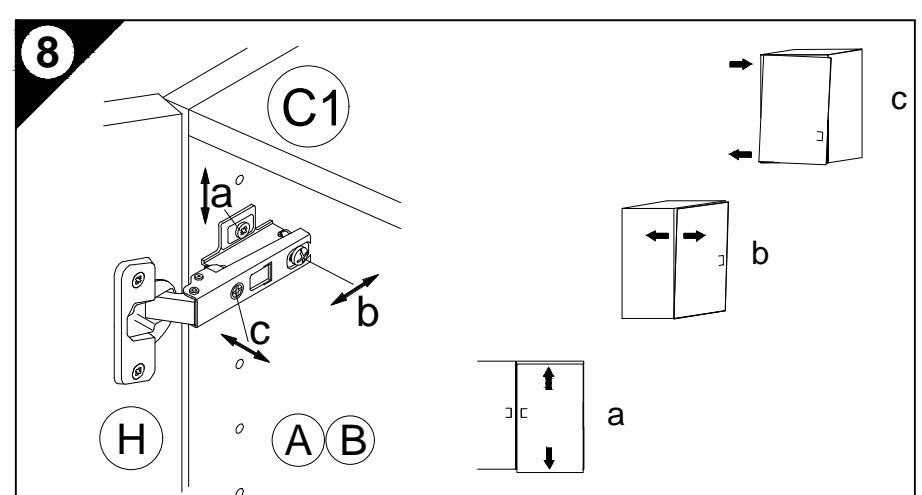
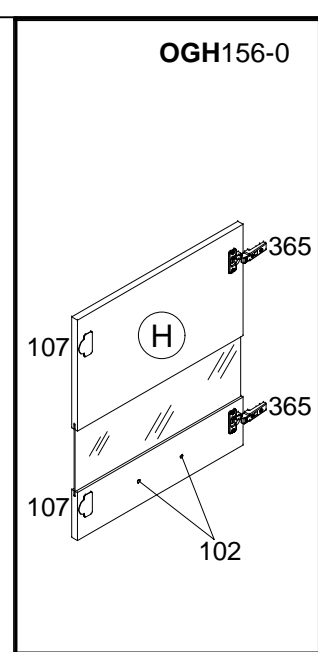
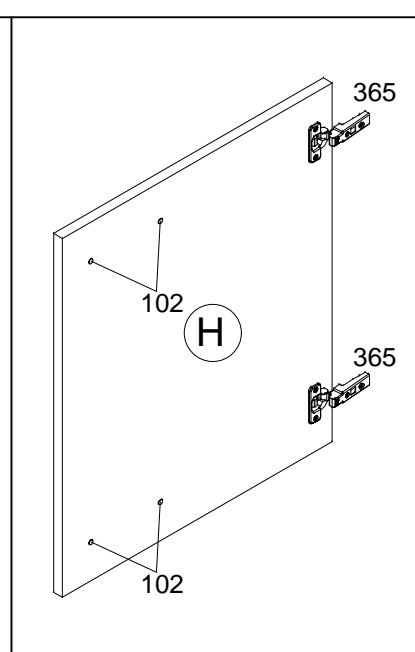
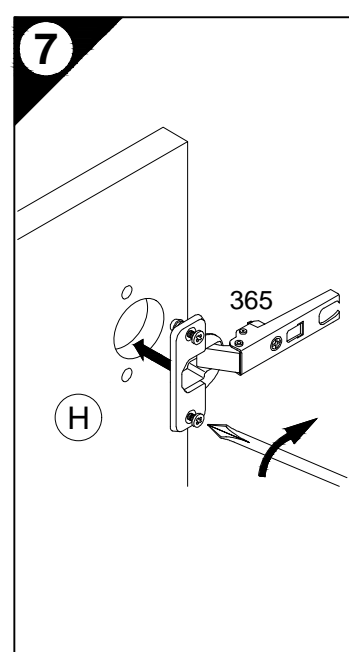
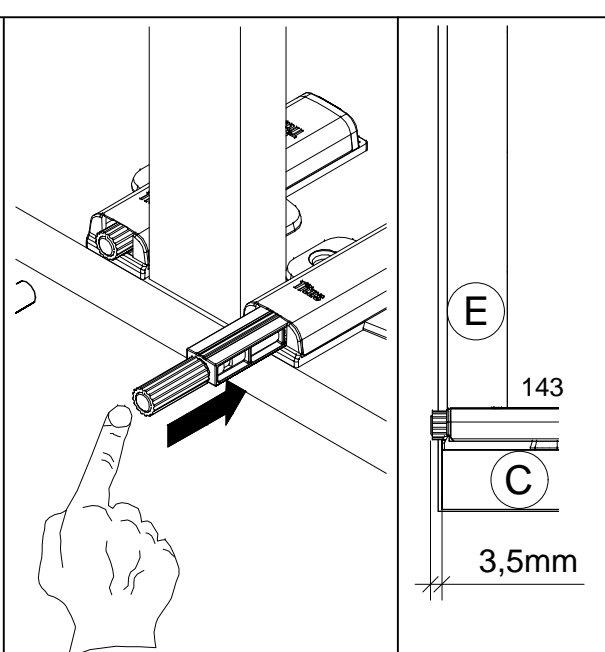
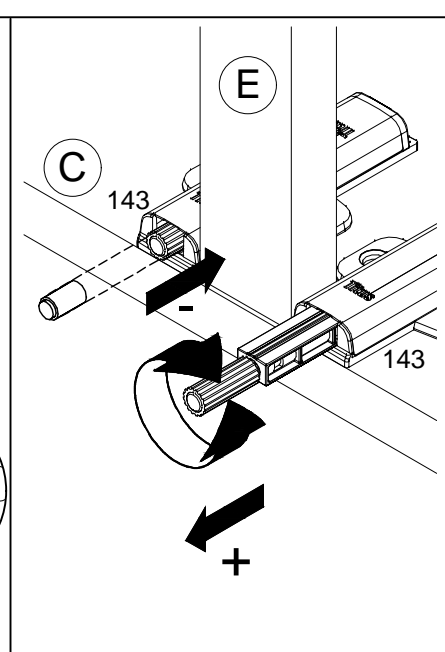
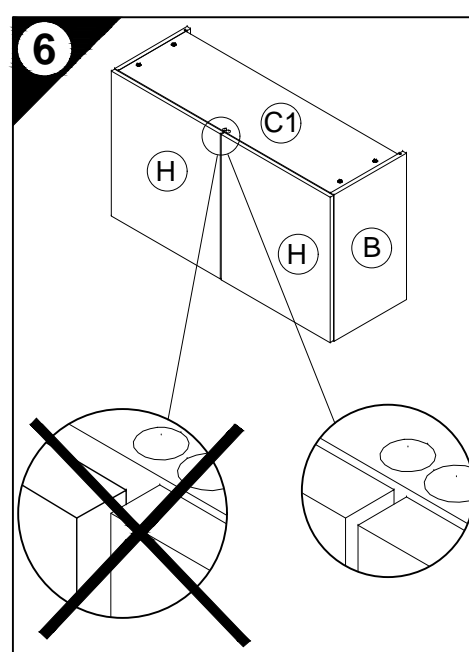
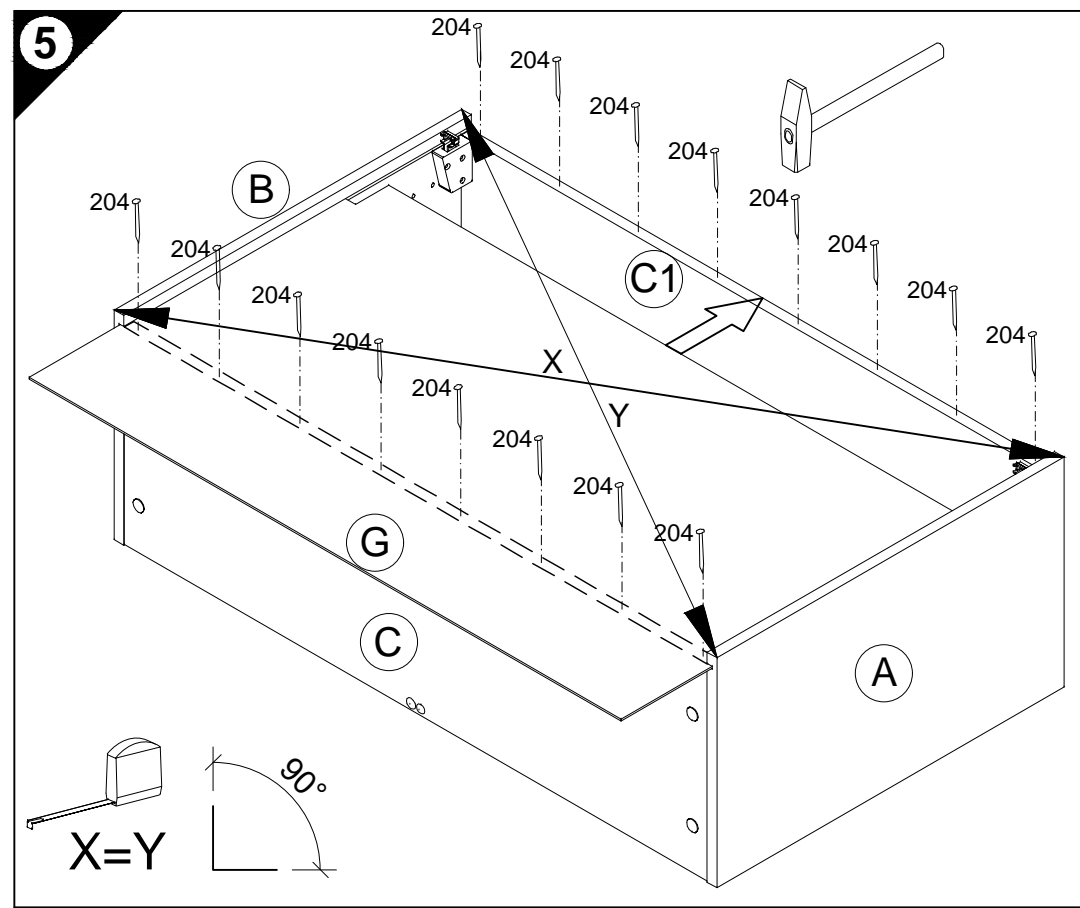
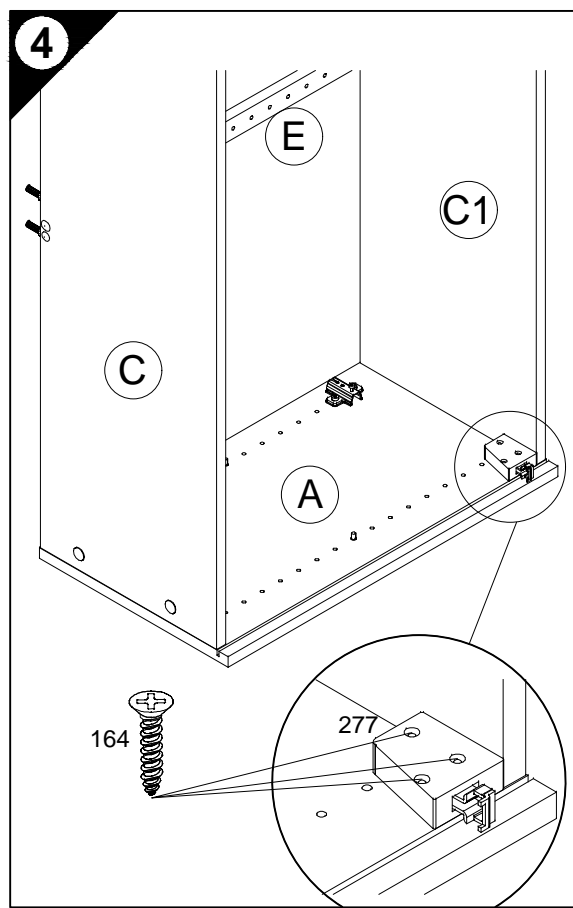
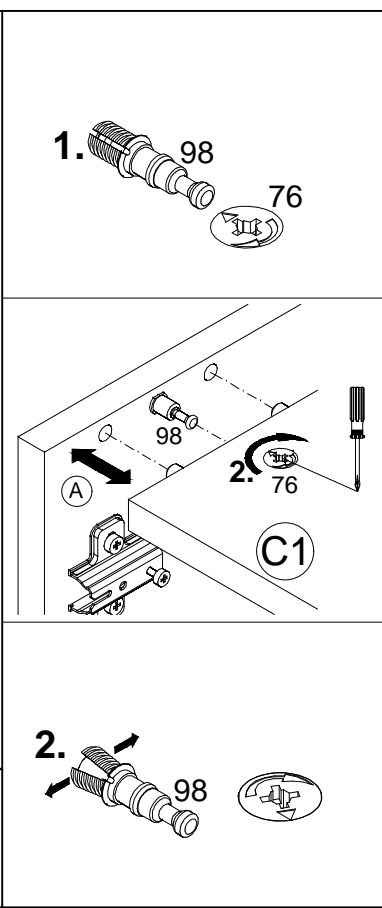
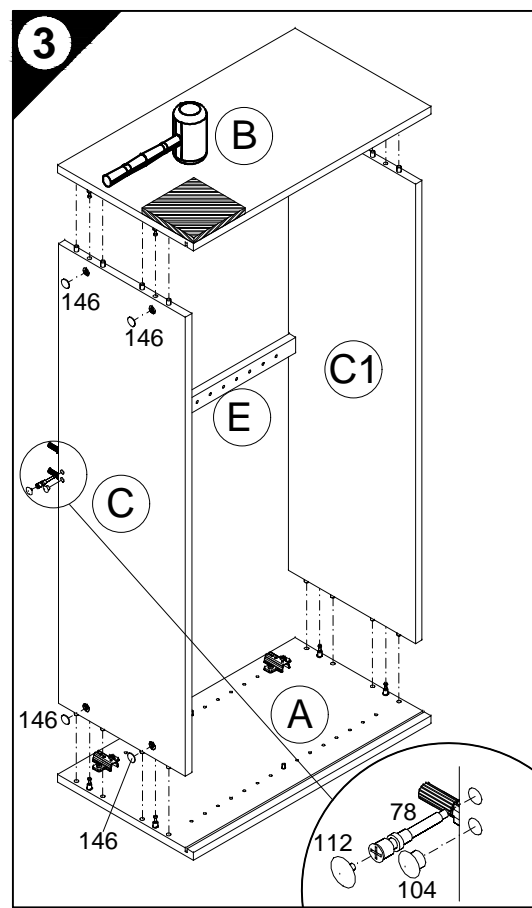

9

D Untergrund und Befestigungsmittel auf Eignung prüfen!
 GB Check substructure and fixings for suitability!
 F Contrôler si le support et les moyens de fixation sont bien adéquats !
 NL Ondergrond en bevestigingsmateriaal op functionaliteit controleren!
 E ¡Comprobar el suelo y los medios de fijación en cuanto a su aptitud!
 I Controllare l'idoneità del fondo e del materiale di fissaggio!
 RUS Основание и крепежный материал проверить на пригодность!
 PL Podłoże oraz materiały do zamocowania sprawdzić na ich przydatność!
 H Az alapelületet és a rögzítő anyagokat megfelelőség szempontjából ellenőrizni kell!
 CZ Přezkoušejte podklad a vhodnost upevňovacích prostředků!
 SLO Preverite, če se ujemajo spodnja stran in pritrđilna sredstva!
 FIN Tarkista alustan ja kiinnitysvälineiden sopivuus!
 S Kontrollera att underlaget och fästmedlen är lämpliga!
 SK Preverte vhodnosť podkladu a upevňovacích prostriedkov!
 RO Verificați caracterul adecvat al suprafeței suport și al mijloacelor de fixare!
 TR Zeminin ve bağlantı elemanlarının uygunluğunu kontrol edin!

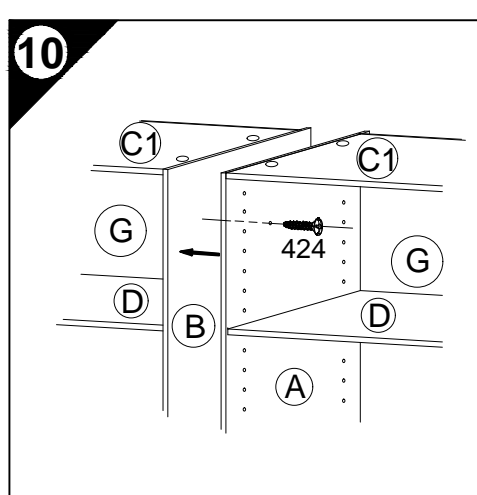
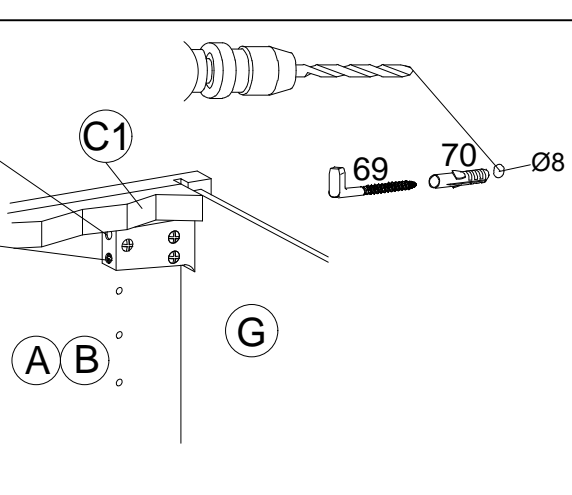

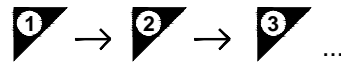
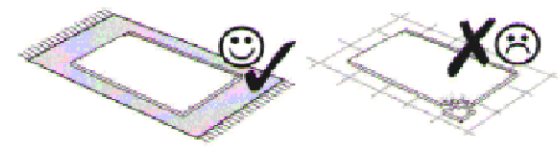
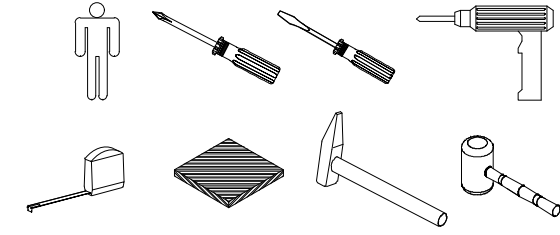

- | | | | |
|----------|--------------------------|--------------------------|----------------------|
| 1 | 8x
Nr.98 | 2x
Nr.367 | 4x
Nr.502 |
| | 2x
Nr.89 | 4x
6,3x12,5
Nr.451 | 2x
4x15
Nr.158 |
| | 2x
6,3x11,5
Nr.535 | | |
| 2 | 8x
Nr.76 | 14x
Ø8x30
Nr.80 | 2x
Ø5x30
Nr.81 |

Montageanleitung

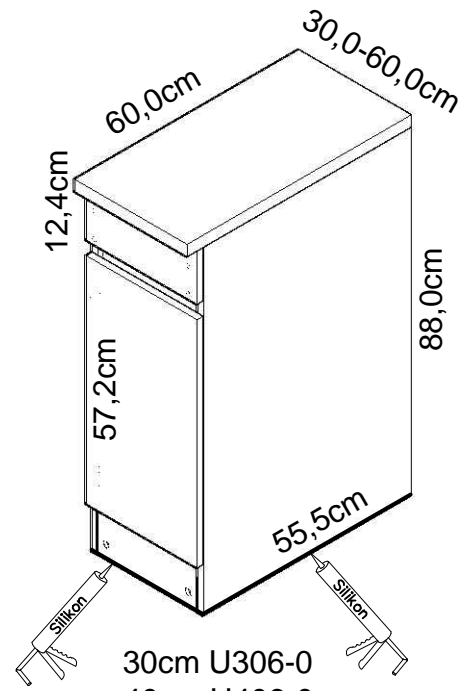

30cm U306-0
40cm U406-0
50cm U506-0
60cm U606-0

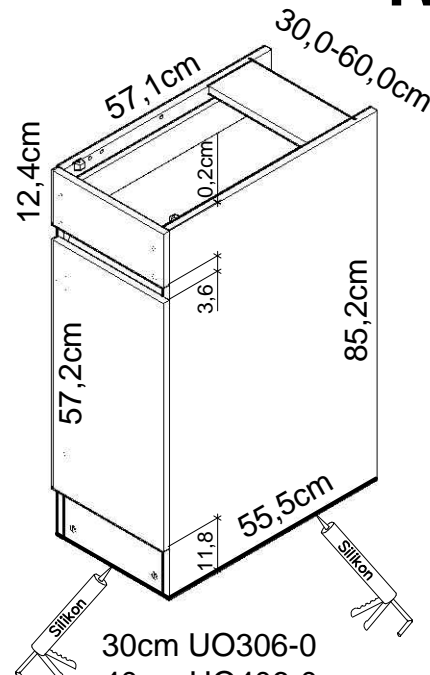

30cm UO306-0
40cm UO406-0
50cm UO506-0
60cm UO606-0

Service-Hotline
01805-678101
0,14€ pro Minute
++49 für Österreich
Auslandstarif pro Minute
service@jaka-bkl.de
voor Nederland en België
00800-40119350
benelux@jaka-bkl.de

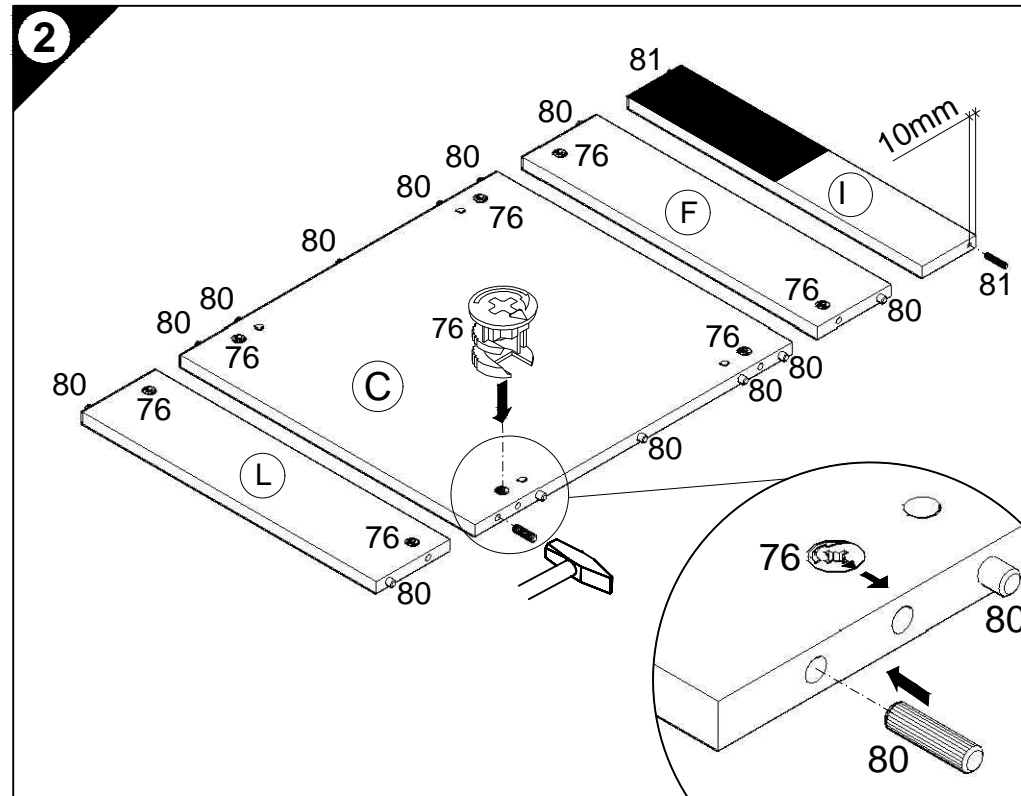
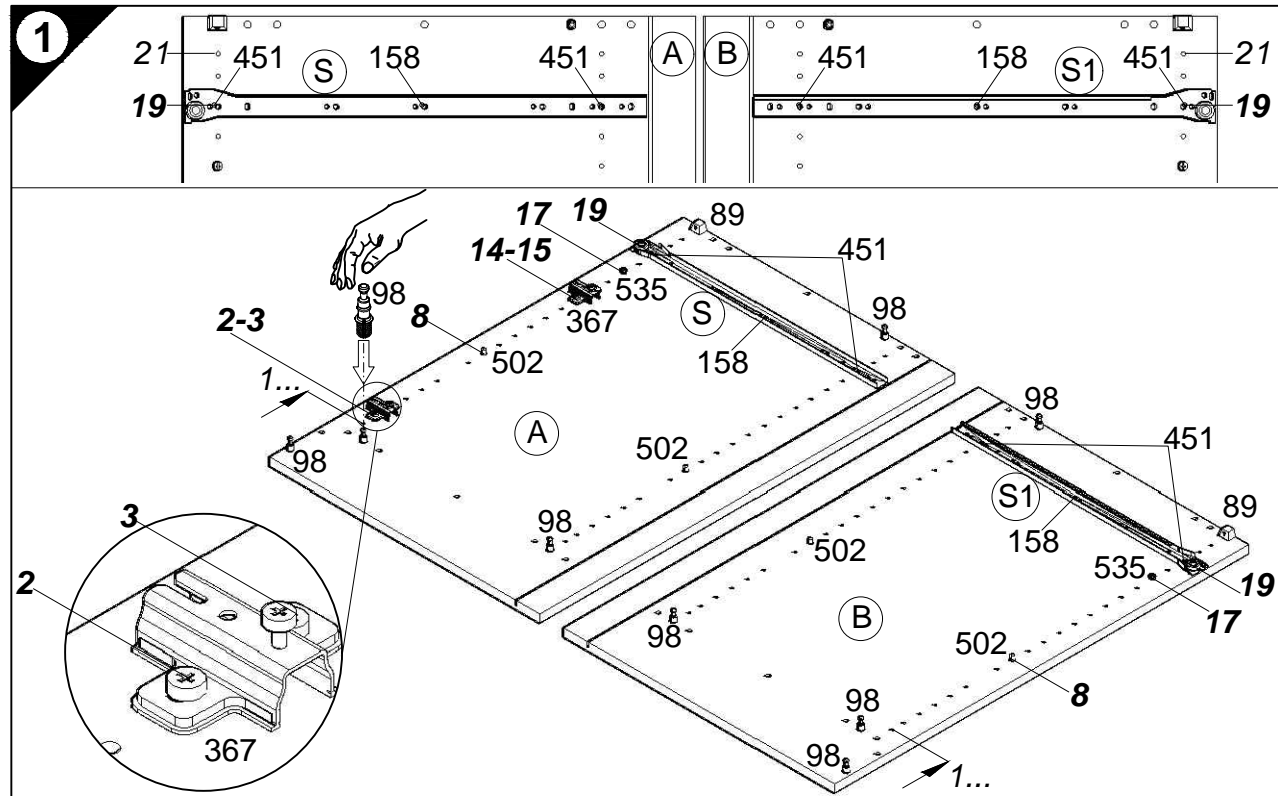
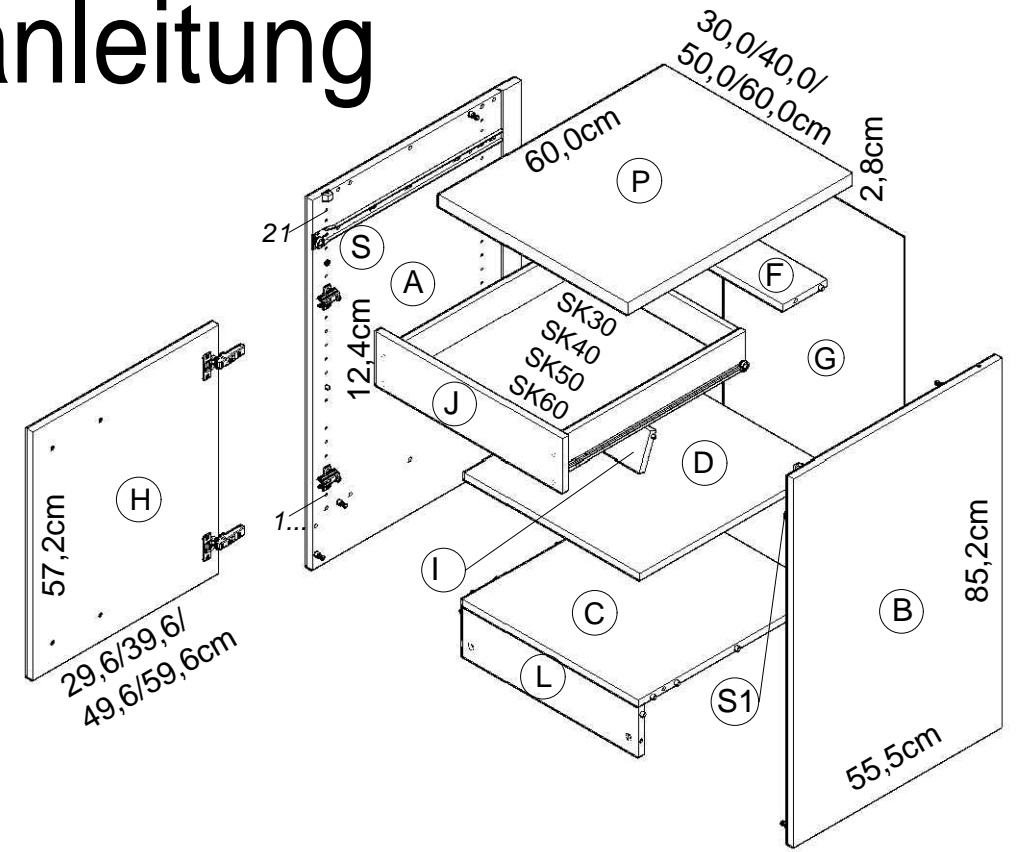

Ersatzteile/Spare parts/pièces de rechange/Reserveonderdelen/Piezas de recambio/Ricambi/Запасные части/Części zamiennie/pótkatárszek/Náhradní části/Nadomestni deli/varaosat/reservdelar/náhradné diely/Utilizați piese de schimb/Yedek parçalar

30cm U306-0	(A) E961033	(B) E961034	(C) E954216	(D) E950306	(F) E970976	(G) E970140	(H) E940614	(I) E970994	(J) E940565	(L) E970976	(P) E540106	(S) E946155	(S1) E946155
30cm UO306-0	(A) E961033	(B) E961034	(C) E954216	(D) E950306	(F) E970976	(G) E970140	(H) E940614	(I) E970994	(J) E940565	(L) E970976	(S) E946155	(S1) E946155	
40cm U406-0	(A) E961033	(B) E961034	(C) E954215	(D) E950305	(F) E970975	(G) E970141	(H) E940613	(I) E970993	(J) E940564	(L) E970975	(P) E540105	(S) E946155	(S1) E946155
40cm UO406-0	(A) E961033	(B) E961034	(C) E954215	(D) E950305	(F) E970975	(G) E970141	(H) E940613	(I) E970993	(J) E940564	(L) E970975	(S) E946155	(S1) E946155	
50cm U506-0	(A) E961033	(B) E961034	(C) E954224	(D) E950304	(F) E970974	(G) E970142	(H) E940612	(I) E970992	(J) E940563	(L) E970974	(P) E540104	(S) E946155	(S1) E946155
50cm UO506-0	(A) E961033	(B) E961034	(C) E954224	(D) E950304	(F) E970974	(G) E970142	(H) E940612	(I) E970992	(J) E940563	(L) E970974	(S) E946155	(S1) E946155	
60cm U606-0	(A) E961033	(B) E961034	(C) E954223	(D) E950303	(F) E970973	(G) E970143	(H) E940611	(I) E970991	(J) E940562	(L) E970973	(P) E540103	(S) E946155	(S1) E946155
60cm UO606-0	(A) E961033	(B) E961034	(C) E954223	(D) E950303	(F) E970973	(G) E970143	(H) E940611	(I) E970991	(J) E940562	(L) E970973	(S) E946155	(S1) E946155	

1 → 2 → 3 ...

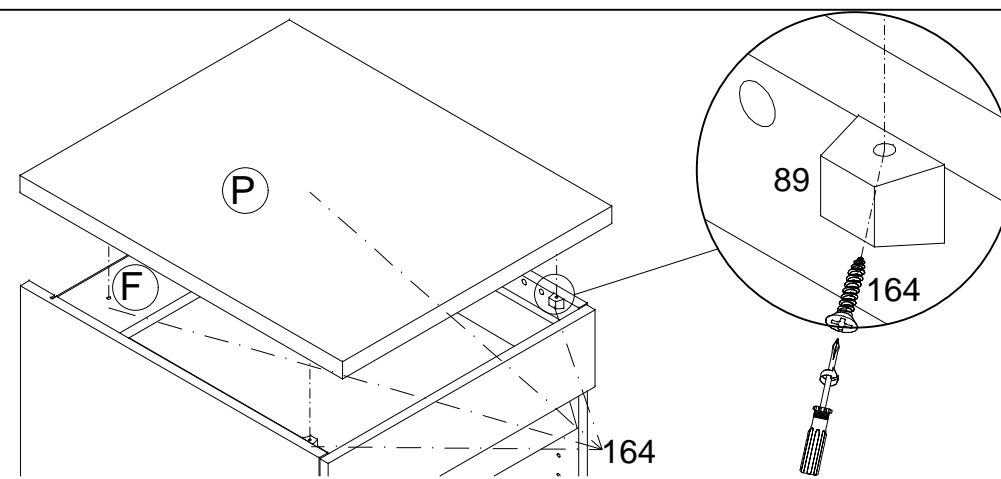
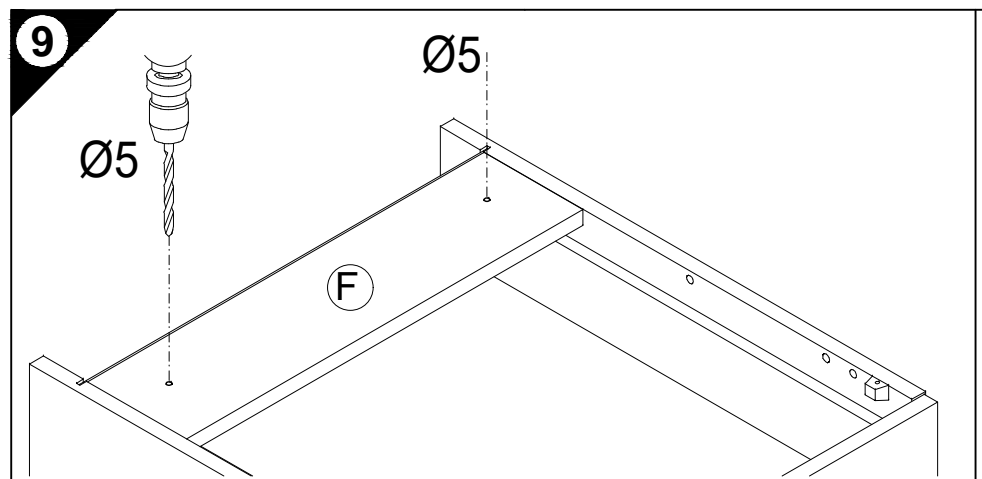
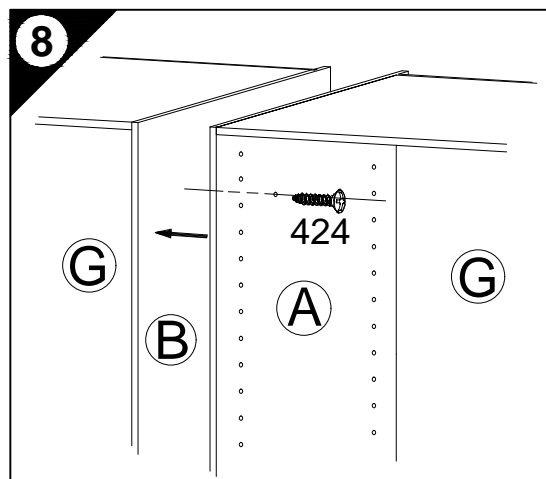
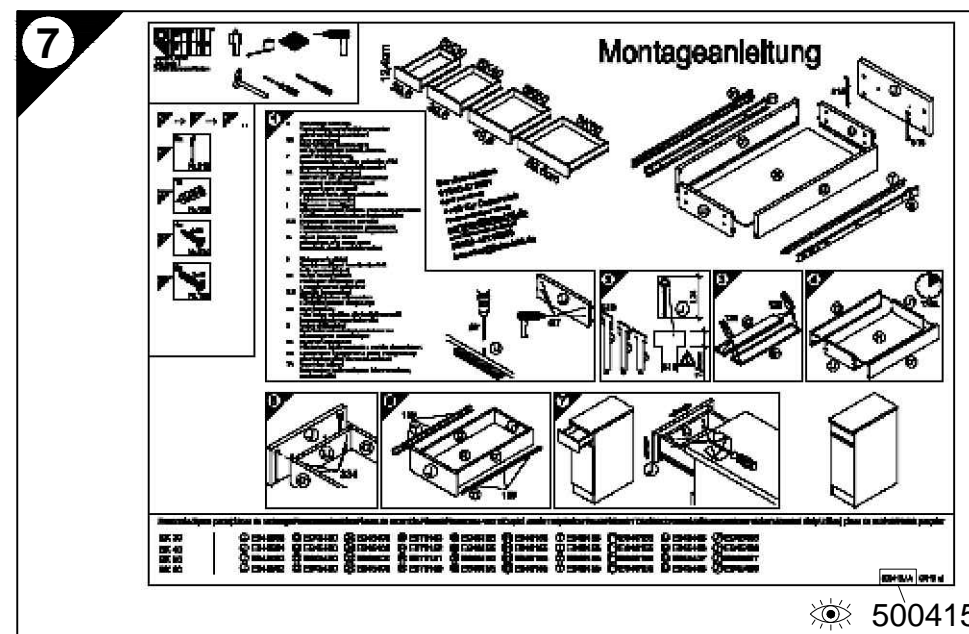
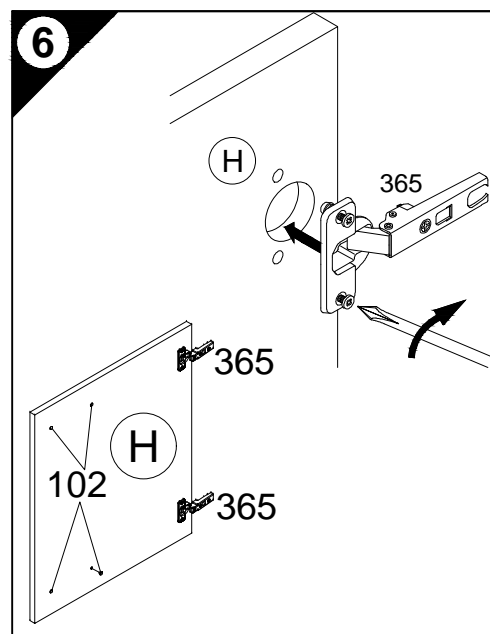
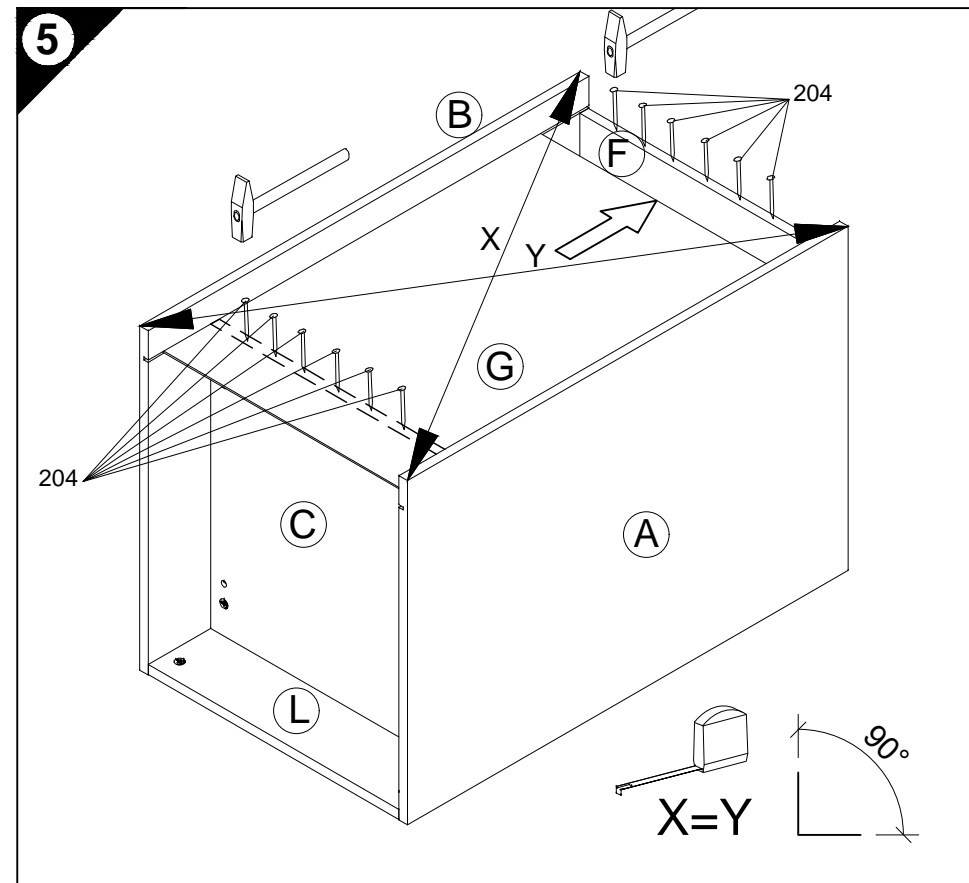
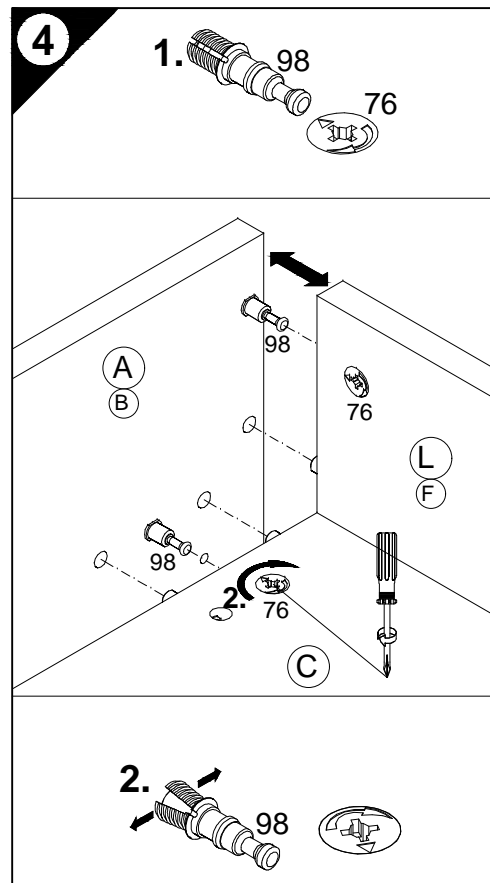
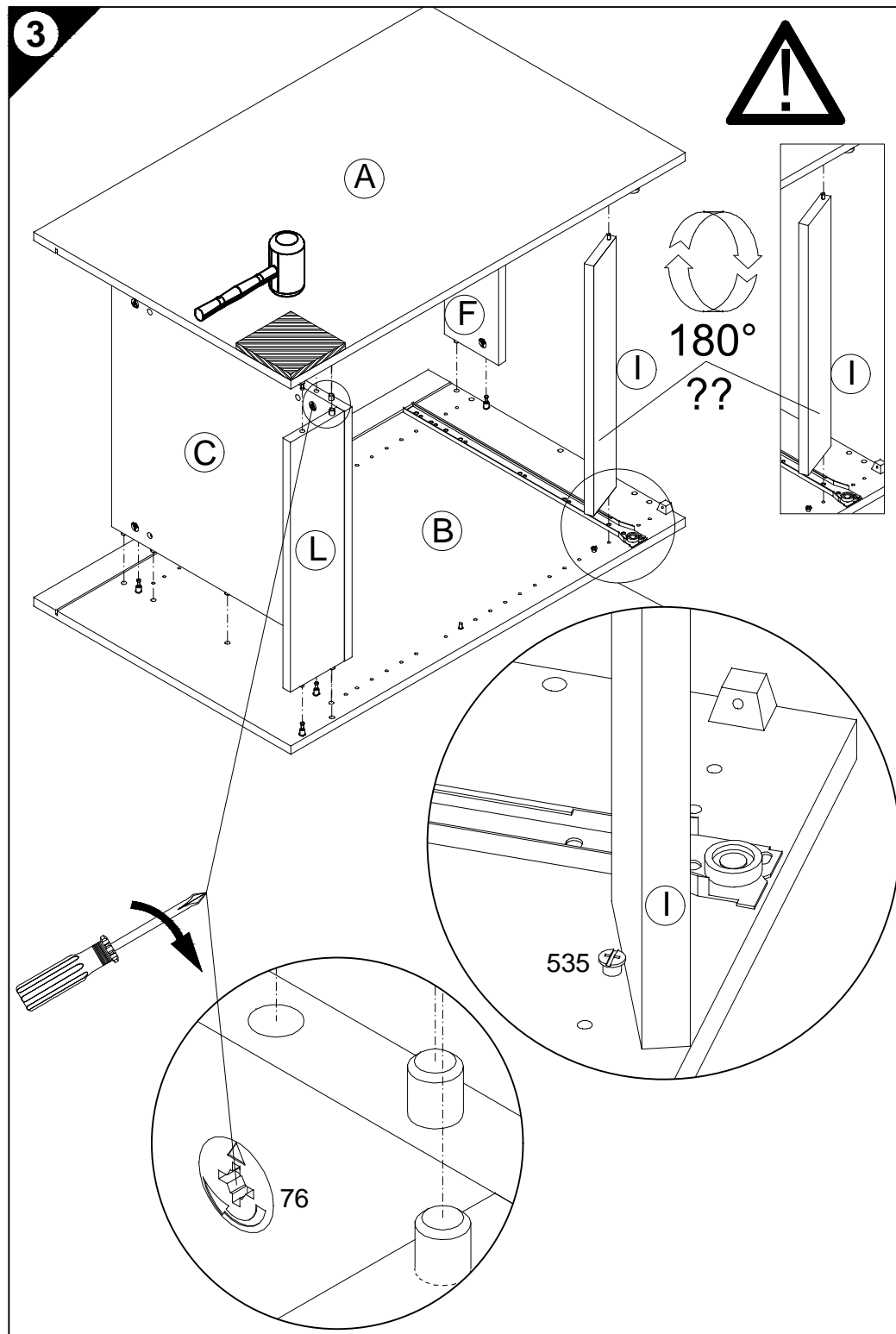
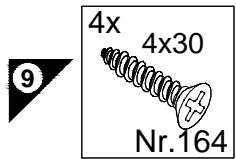
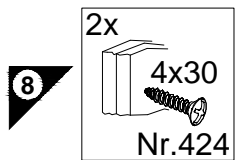
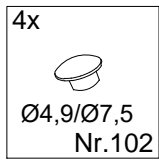
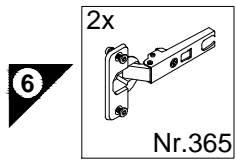
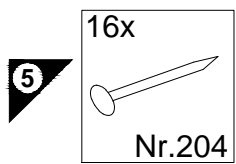

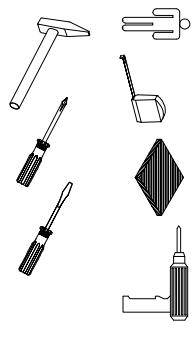

Montageanleitung

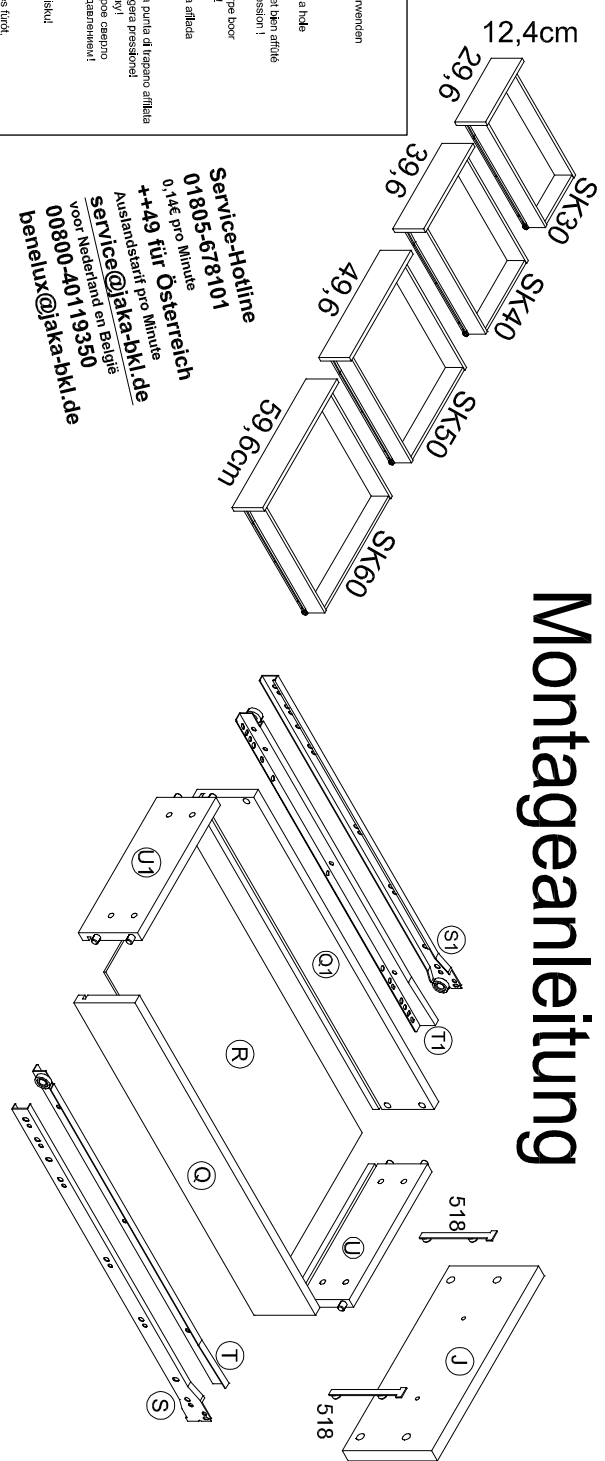

Service-Hotline
01805-678101
0,14€ pro Minute
+++49 für Österreich
Austandstarf pro Minute
service@jaka-bk1.de
voor Nederland en België
00800-40119350
benelux@jaka-bk1.de

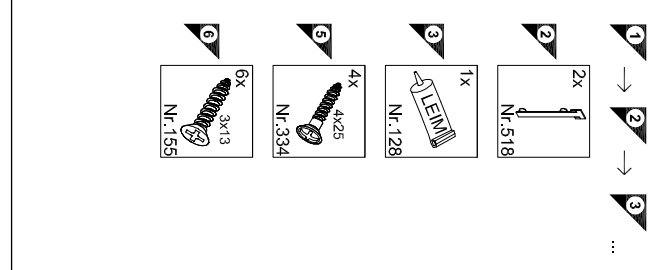

1
D
Házkundilage venovenit!
Front anbrücken, schrauben festziehen
und mit wenig Druck durchbohren!
Use a wooden base!
Press front down, use sharp drill bit
until it is through!
Appuyer sur la façade, utiliser un foret bien affilé
et pousser en appliquant une faible pression!
Nålen ordeligger drävkent!
Druk het front aan, gebruik een scherpe boor-
er oefen bij het boren weinig druk uit!
Utiliser una base de madera!
¡Métalo con poca presión!
Appoggare la facciata, utilizzare una punta di trapano affilata
e far passare agevolmente solo una leggera pressione!
RUS Исползовать деревянную подложку!
Примать фасад, использовать острого сверло
и просверлить с незначительным давлением!
PL Użyć drewniane 2 drzewo!
Dociąć front, użyć ostrego młota
Przewnieć, używając małej siły nacisku!
H Altkundazion la alidat!
Norma le az alidat, használdon éles fűrt,
és kis nyomással fúrja át!
CZ Použítte dřevěný podklad!
Přitlačte kálo, použítte ostrý vrák
a provrtěte pomocí měkkého tlaku!
SLO Uporabite leseno podlagi!
Prisilnite klotno ter z ostrin sredcom
Kot pri vajenju pritiskom izvajajo lahki
Rus Поверх подложки, используйте
острый сверло и просверлите с незначительным давлением!
S Puhata nelka van keuyest painemäl!
Avušno ett l'handelgel!
Tryck fronten mot underlaget, använd vass boor
och borra igenom med ett lätt tryck!
SK Použitie drevený podklad!
Prítlačte front, použítte ostrý vrák a prevrtajte miernym tlakom!
RO suport de lemn, împingeți frontul, utilizați un bulgăruș ascuțit
Avșap basn kalidat!
Avšap basn kalidat!
Avšap basn kalidat!
Avšap basn kalidat!

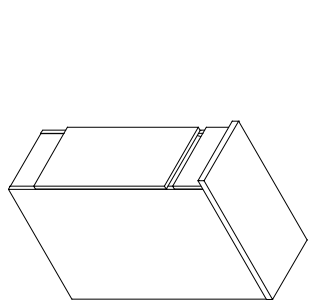
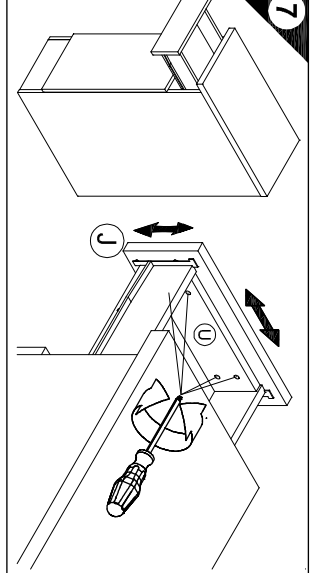
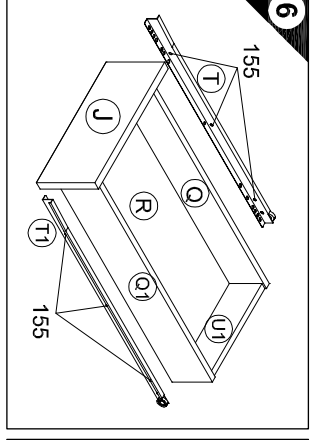
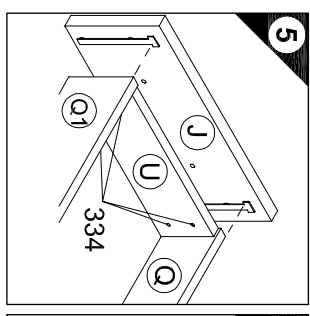
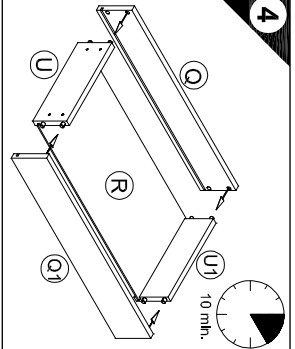
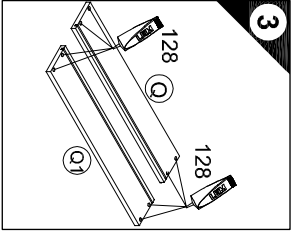
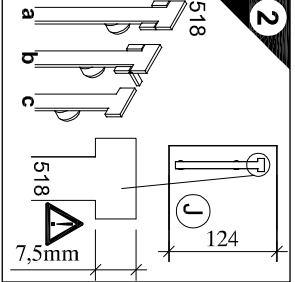
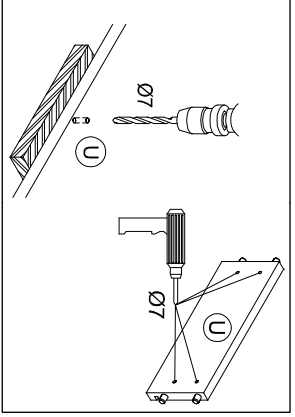

Ersatzteile/Spare parts/pièces de rechange/Reserveonderdelen/Pezzas de recambio/Ricambi/Запасные части/Części zamienne/pótkalkatészczák/Náhradní části/Nadomesni deli/varaosaz/reservdelar/náhradné diely/Utilizati piese de schimb/Υεδεκ παρταlar

SK 30	U E940565	C E945400	Q1 E945400	R E970153	S E946155	S1 E946155	T E946155	T1 E946155	U E945405	U1 E945405
SK 40	U E940564	C E945400	Q1 E945400	R E970152	S E946155	S1 E946155	T E946155	T1 E946155	U E945406	U1 E945406
SK 50	U E940563	C E945400	Q1 E945400	R E970151	S E946155	S1 E946155	T E946155	T1 E946155	U E945407	U1 E945407
SK 60	U E940562	C E945400	Q1 E945400	R E970150	S E946155	S1 E946155	T E946155	T1 E946155	U E945408	U1 E945408

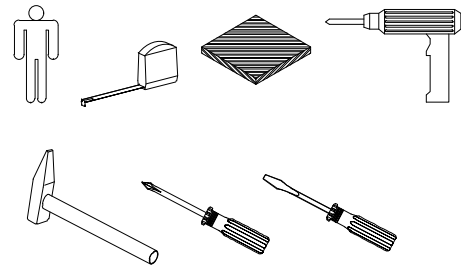

Service-Hotline
01805-678101
0,14€ pro Minute
+49 für Österreich
Auslandstarif pro Minute
service@jaka-bkl.de
voor Nederland en België
00800-40119350
benelux@jaka-bkl.de

Montageanleitung

1 → 2 → 3 ...

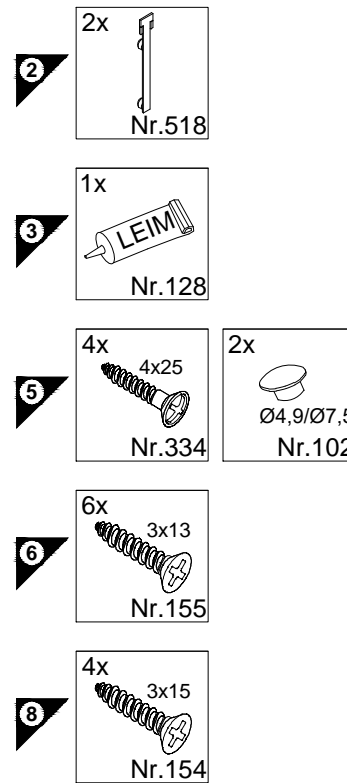

1

D Holzunterlage verwenden!
Front andrücken, scharfen Bohrer verwenden und mit wenig Druck durchbohren!

GB Use a wooden base!
Press front down, use sharp drill bit and, by applying slight pressure, drill a hole

F Utiliser un support en bois!
Appuyer sur la façade, utiliser un foret bien affûté et percer en appliquant une faible pression!

NL Houten onderlegger gebruiken!
Druk het front aan, gebruik een scherpe boor en oefen bij het boren weinig druk uit!

E Utilizar una base de madera!
Presionar el frente, utilizar una broca afilada y taladrar con poca presión!

I Utilizzare una base di legno!
Appoggiare la facciata, utilizzare una punta di trapano affilata e trapanare esercitando solo una leggera pressione!

RUS Использовать деревянную подложку!
Прижать фасад, использовать острое сверло и просверлить с незначительным давлением!

PL Używać podkładkę z drewna!
Docisnąć front, użyć ostrego wiertła i przewiercić, używając małej siły nacisku!

H Alkalmazzon fa alátétet!
Nyomja le az előlapot, használjon éles fúrót, és kis nyomással fúrja át!

CZ Použijte dřevěný podklad!
Přitlačte čelo, použijte ostrý vrták a provrtajte pomocí malého tlaku!

SLO Uporabite leseno podlago!
Pritisnite ličnico ter z ostrim svedrom in z majhnim pritiskom izvrtajte luknjo!

FIN Käytä puualustaa!
Paina etulevy paikoilleen, käytä terävää poranterää ja poraa reikä vain kevyesti painamalla!

S Använd ett träunderlag!
Tryck fronten mot underlaget, använd vass borr och borra igenom med ett lätt tryck!

SK Použite drevený podklad!!
Pritlačte front, použite ostrý vrták a prevrtajte miernym tlakom!

RO suport de lemn! Împingeți frontul, utilizați un burghiu ascuțit și perforați exercitând doar o presiune redusă!

TR Ahşap taban kullanın!
Önden bastırın, keskin matkap ucu kullanın ve az basınç uygulayarak delin!

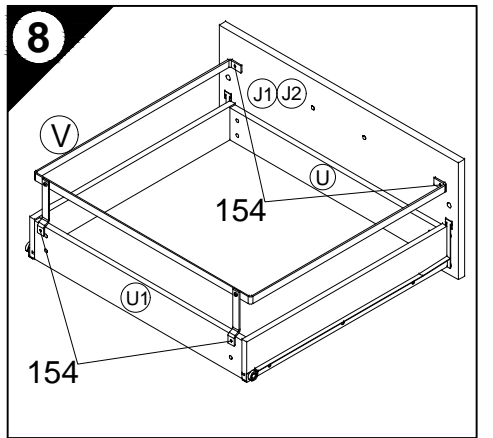
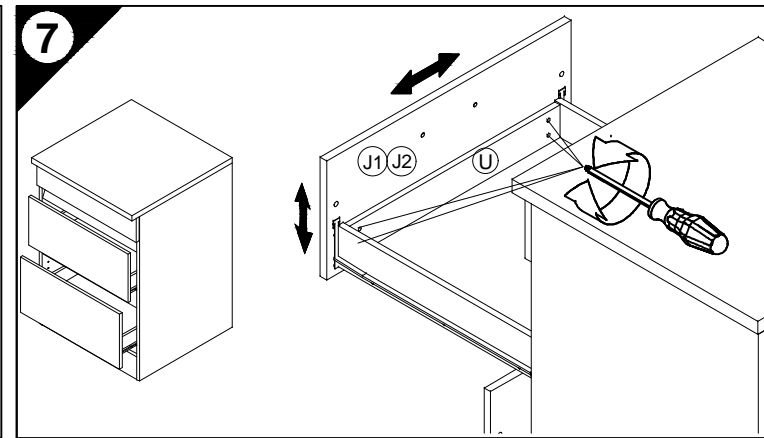
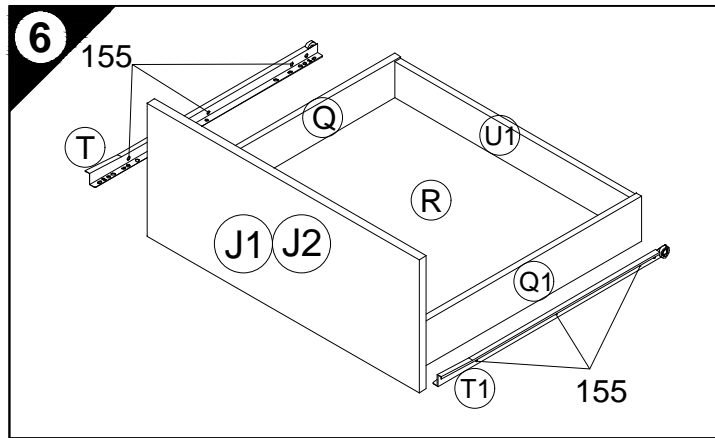
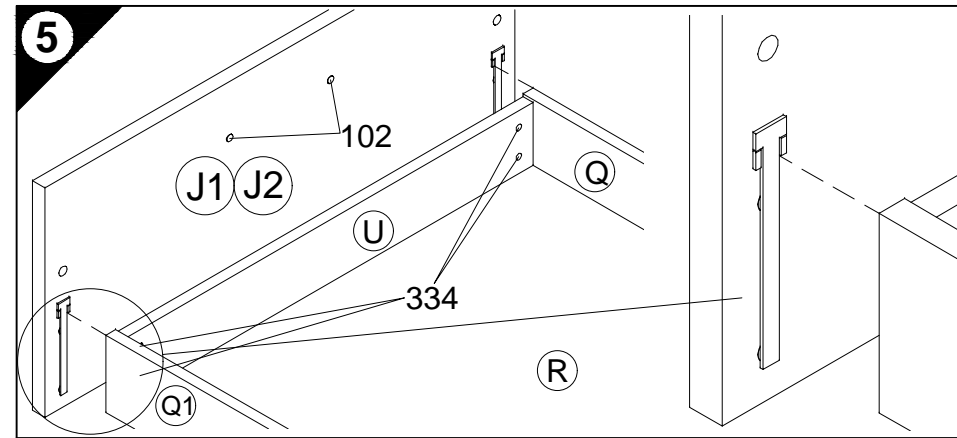
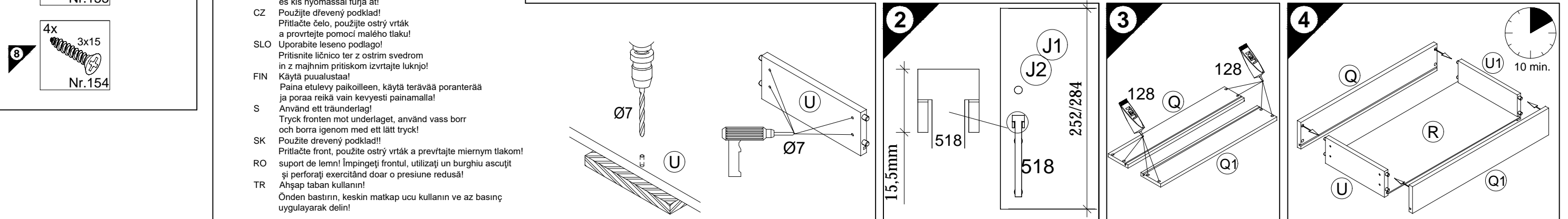
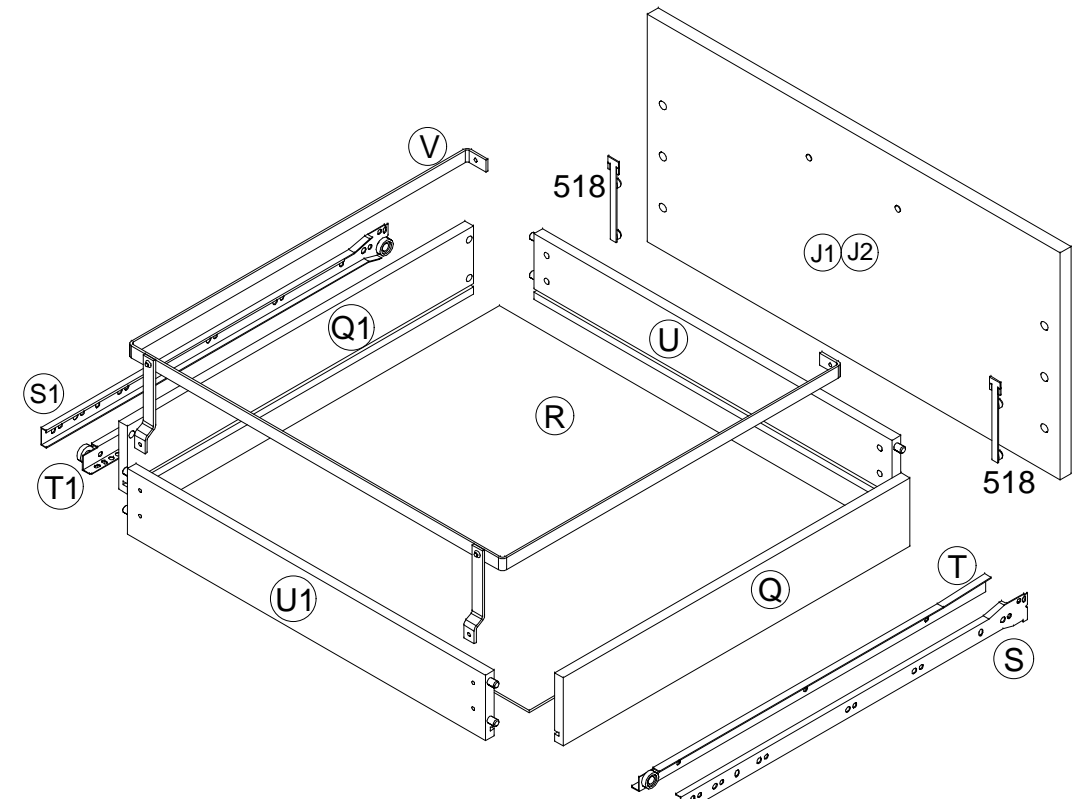
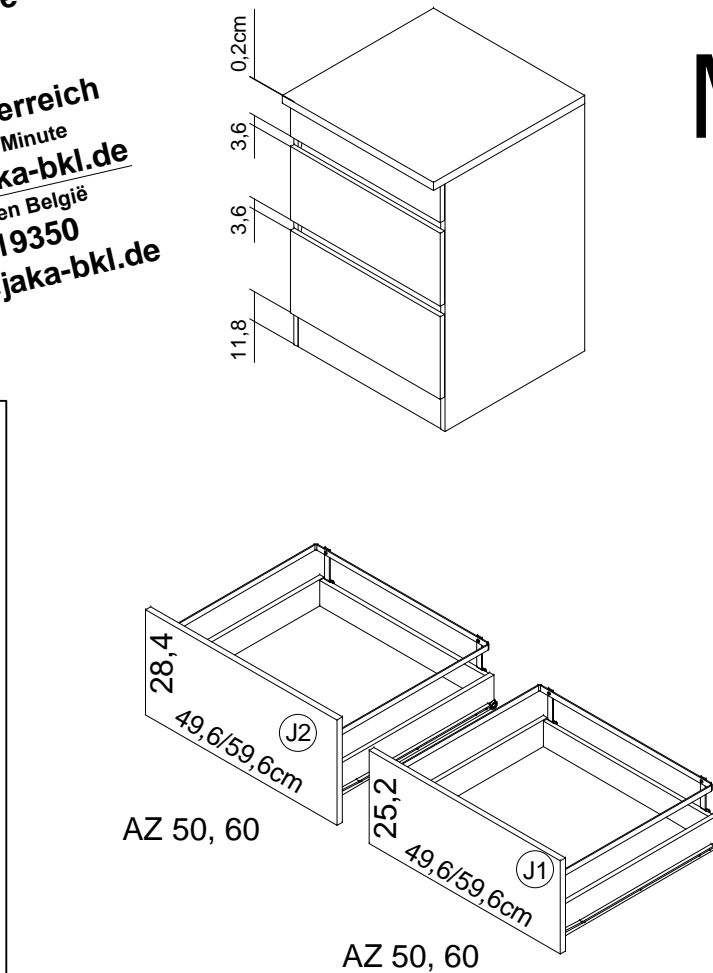

Ersatzteile/Spare parts/pièces de rechange/Reserveonderdelen/Piezas de recambio/Ricambi/Запасные части/Części zamienne/pótkatrészek/Náhradní části/Nadomestni deli/varaosat/reservdelar/náhradné diely/Utilizați piese de schimb/Yedek parçalar

AZ 60	J1 E940591	J2 E940587	Q E945400	Q1 E945400	R E970150	S E946155	S1 E946155	T E946155	T1 E946155	U E945408	U1 E945408	V E446167
AZ 50	J1 E940592	J2 E940588	Q E945400	Q1 E945400	R E970151	S E946155	S1 E946155	T E946155	T1 E946155	U E945407	U1 E945407	V E446166

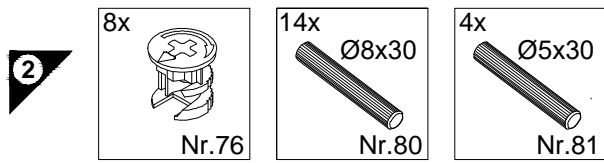
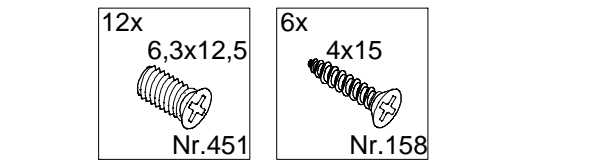
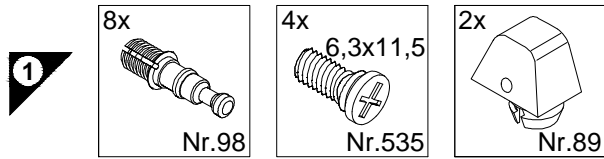
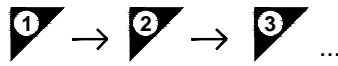
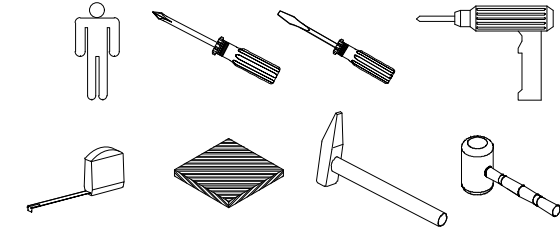

Service-Hotline
01805-678101
0,14€ pro Minute
++49 für Österreich
Auslandstarif pro Minute
service@jaka-bkl.de
voor Nederland en België
00800-40119350
benelux@jaka-bkl.de

Montageanleitung

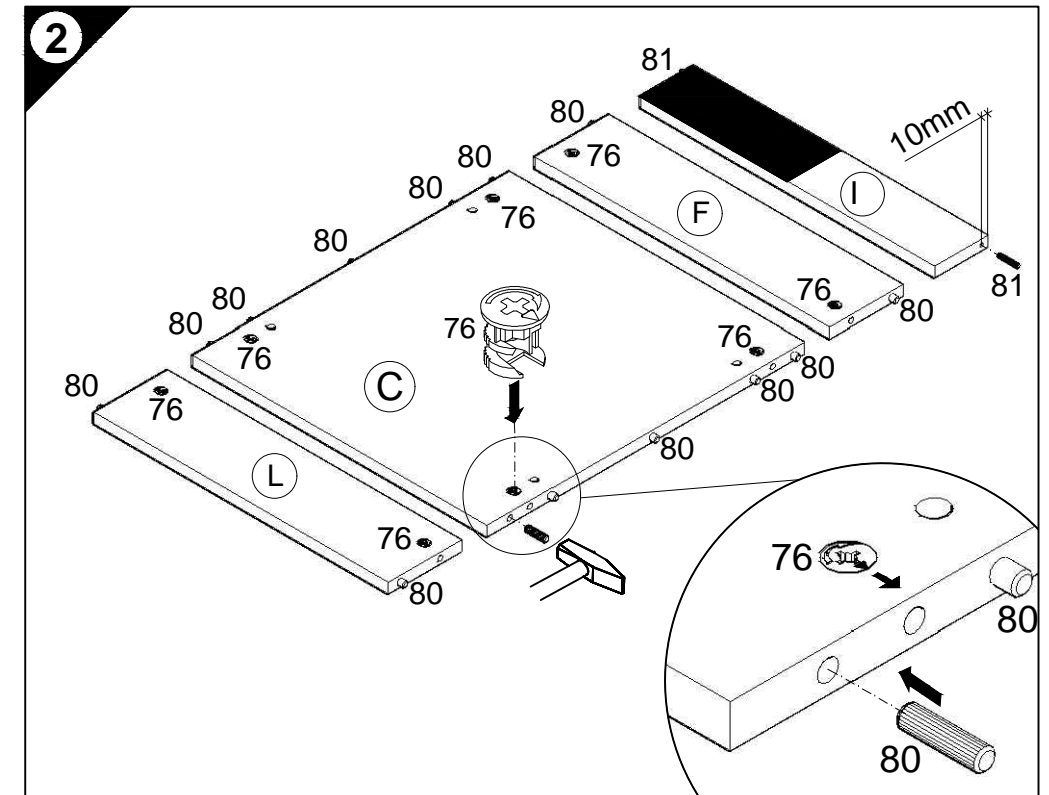
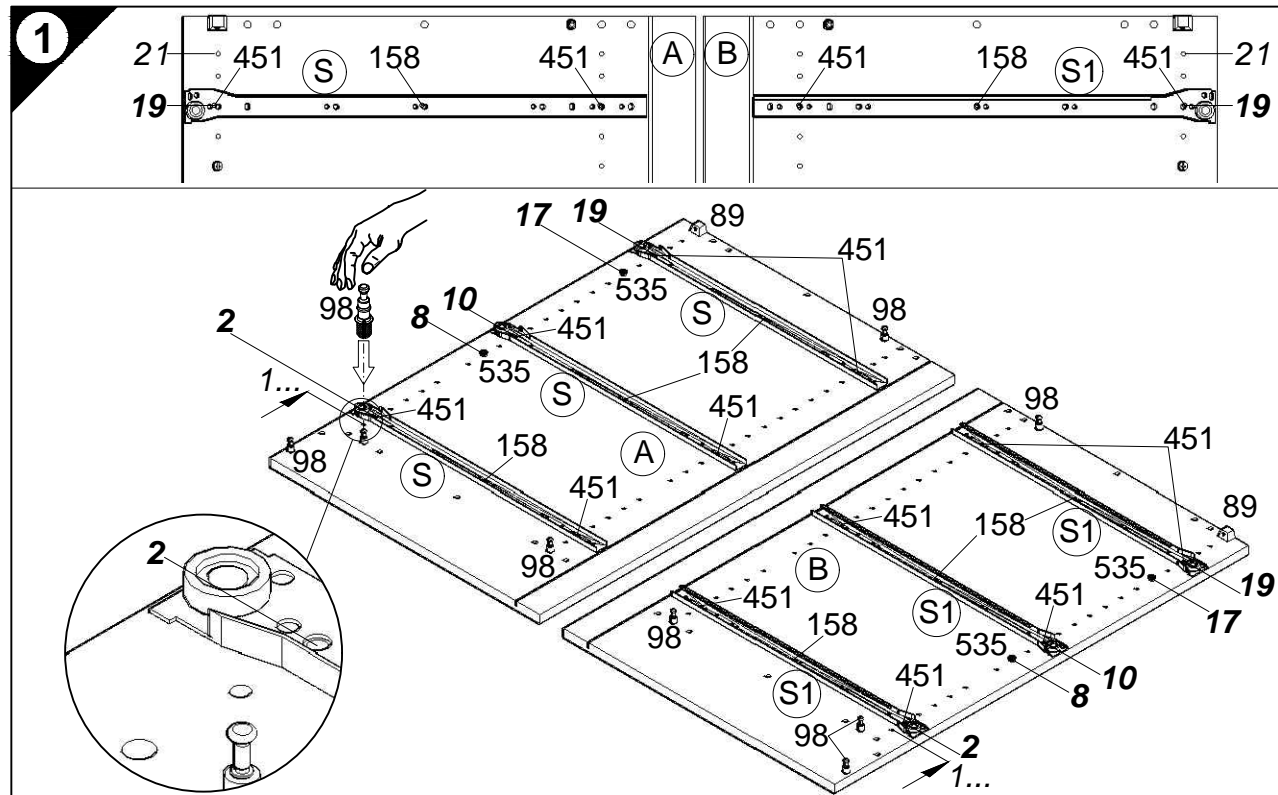
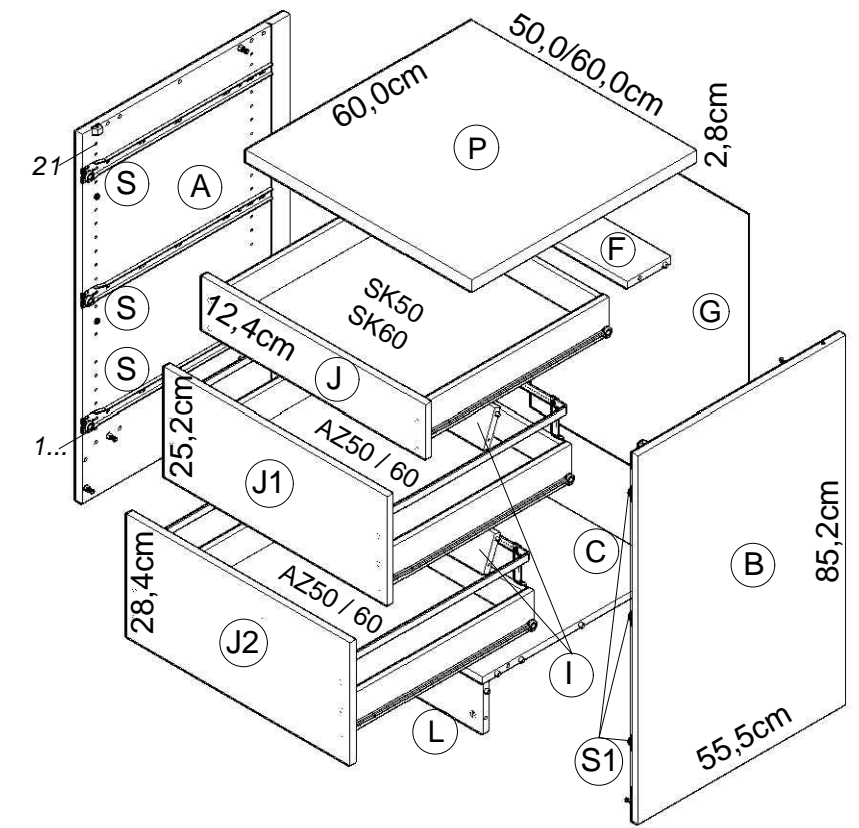
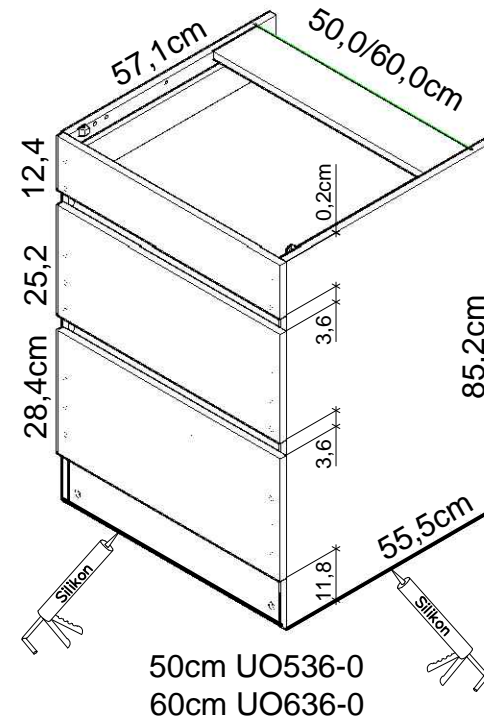
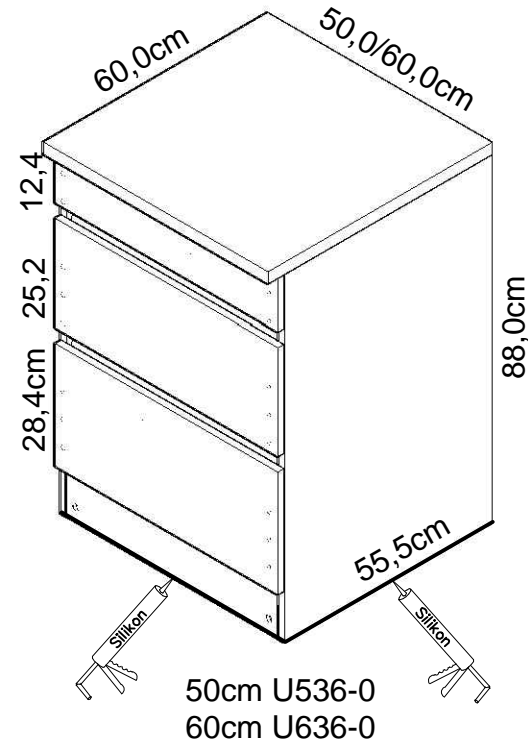

Ersatzteile/Spare parts/pièces de rechange/Reserveonderdelen/Piezas de recambio/Ricambi/Запасные части/Części zamienne/pótkatrészek/Náhradní části/Nadomestni deli/varaosat/reservdelar/náhradné diely/Utilizați piese de schimb/Yedek parçalar

50cm U536-0	(A) E961033	(B) E961034	(C) E954224	(F) E970974	(G) E970142	(I) E970992	(J) E940563	(J1) E940592	(J2) E940588	(L) E970974	(P) E540104	(S) E946149	(S1) E946148
50cm UO536-0	(A) E961033	(B) E961034	(C) E954224	(F) E970974	(G) E970142	(I) E970992	(J) E940563	(J1) E940592	(J2) E940588	(L) E970974	(S) E946149	(S1) E946148	
60cm U636-0	(A) E961033	(B) E961034	(C) E954223	(F) E970973	(G) E970143	(I) E970991	(J) E940562	(J1) E940591	(J2) E940587	(L) E970973	(P) E540103	(S) E946149	(S1) E946148
60cm UO636-0	(A) E961033	(B) E961034	(C) E954223	(F) E970973	(G) E970143	(I) E970991	(J) E940562	(J1) E940591	(J2) E940587	(L) E970973	(S) E946149	(S1) E946148	

1 → 2 → 3 ...

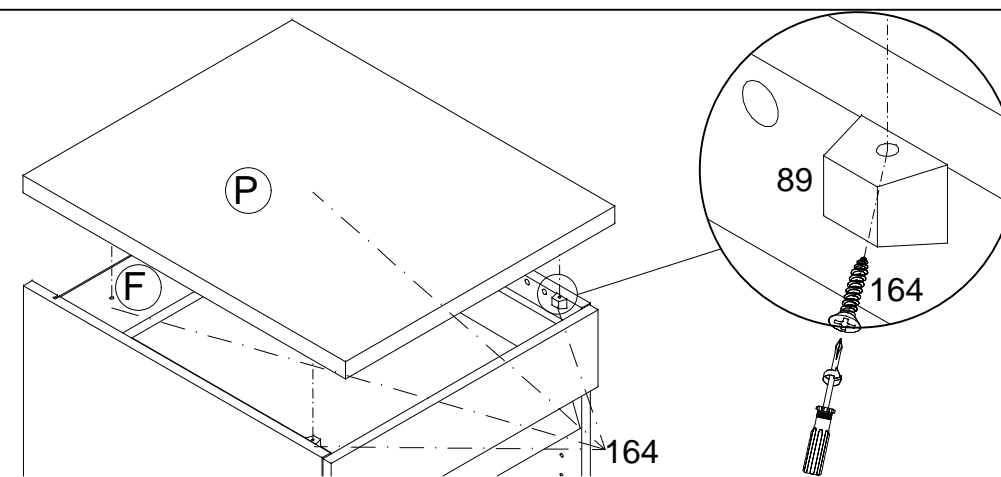
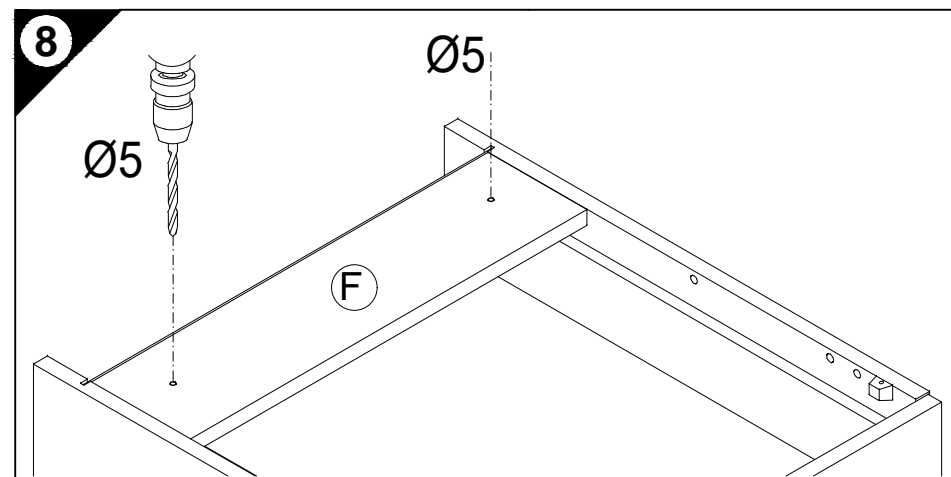
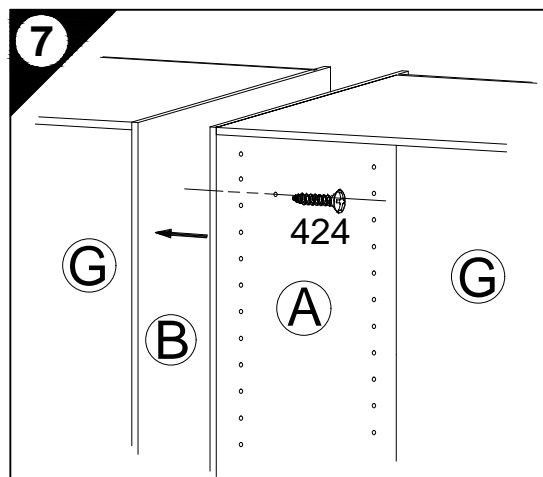
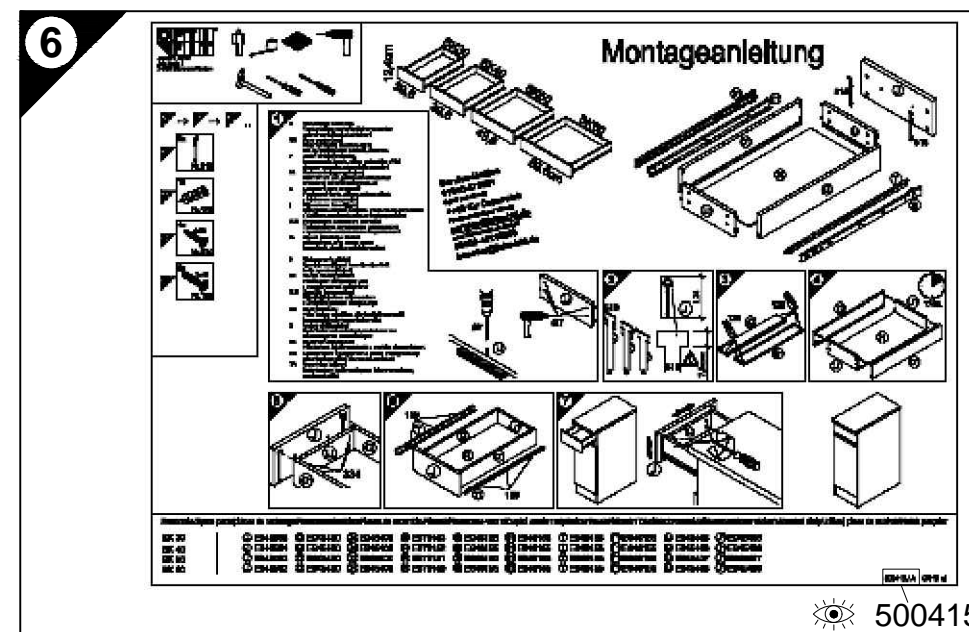
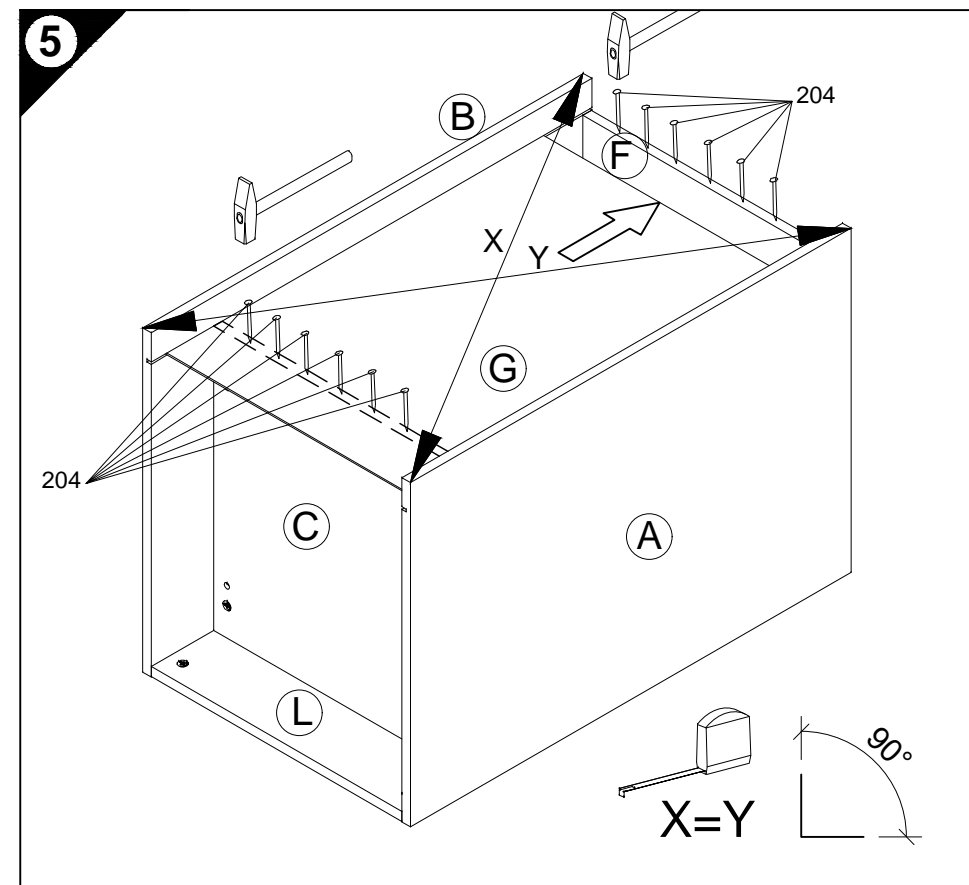
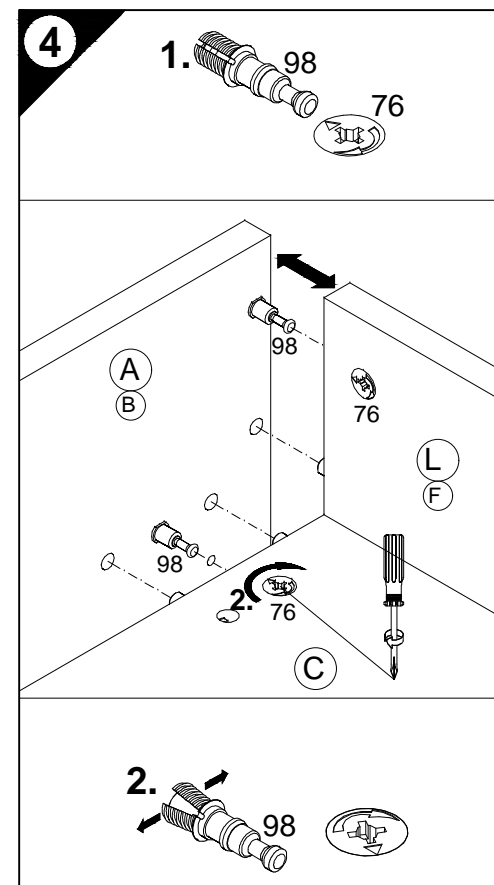
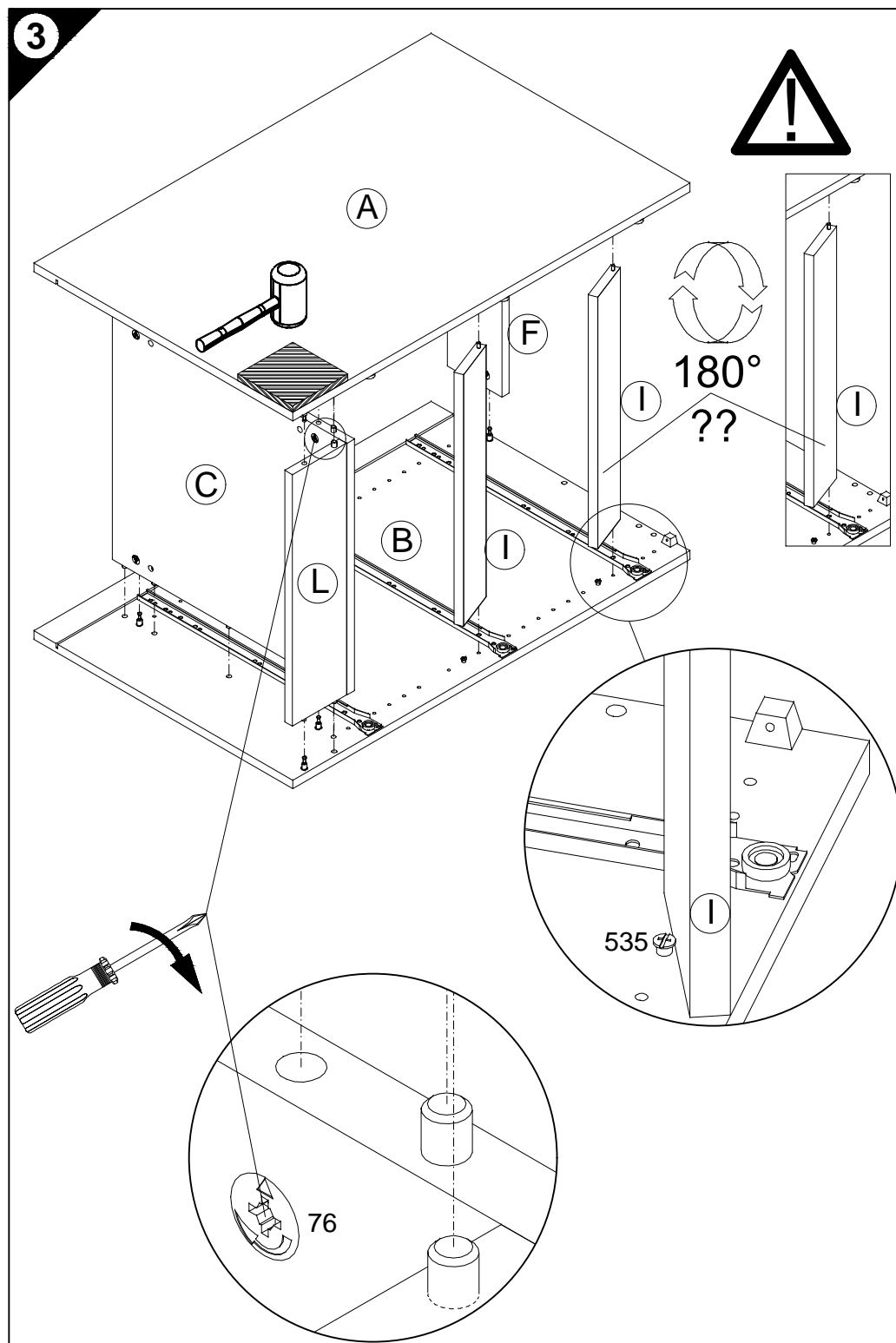
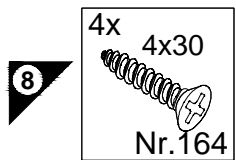
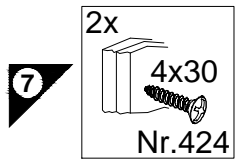
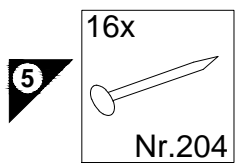

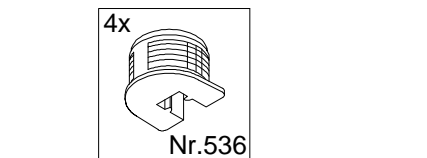
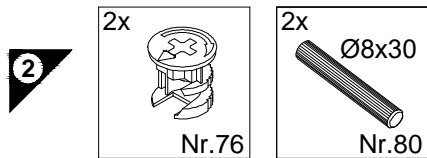
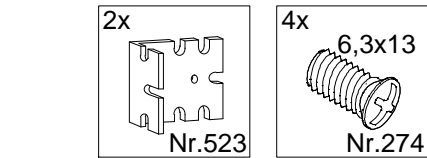
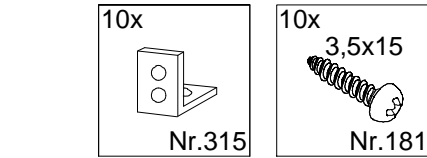
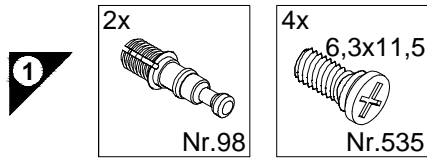
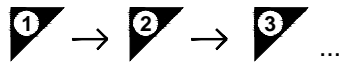
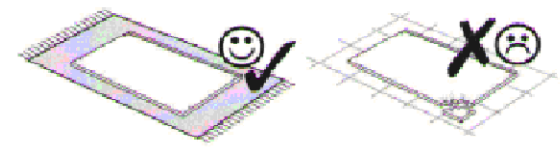
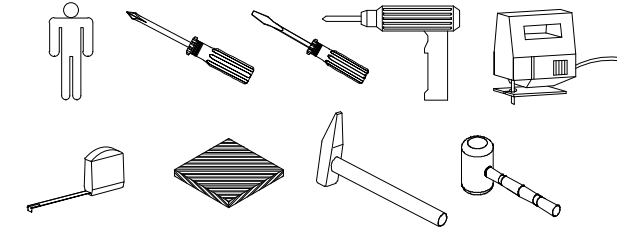

Montageanleitung

Service-Hotline
01805-678101
0,14€ pro Minute
++49 für Österreich
Auslandstarif pro Minute
service@jaka-bkl.de
voor Nederland en België
00800-40119350
benelux@jaka-bkl.de

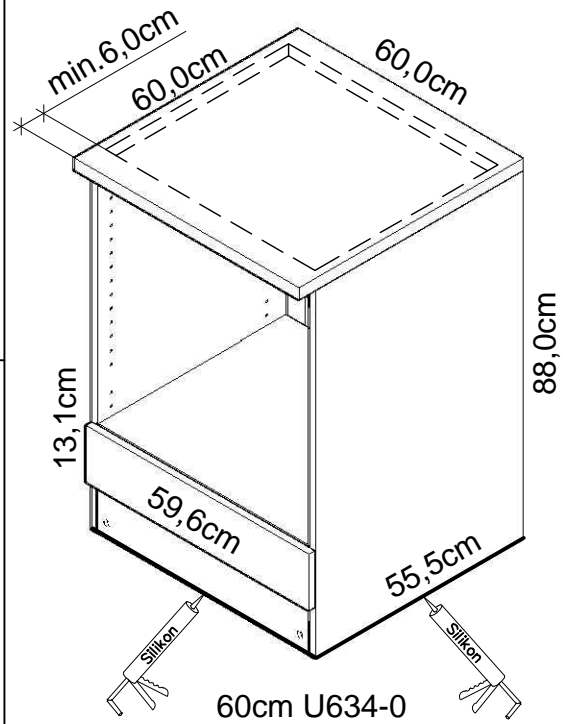

60cm U634-0

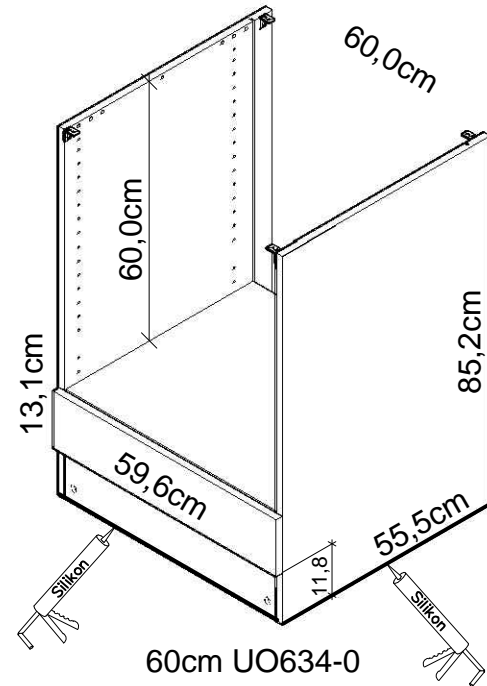

60cm UO634-0

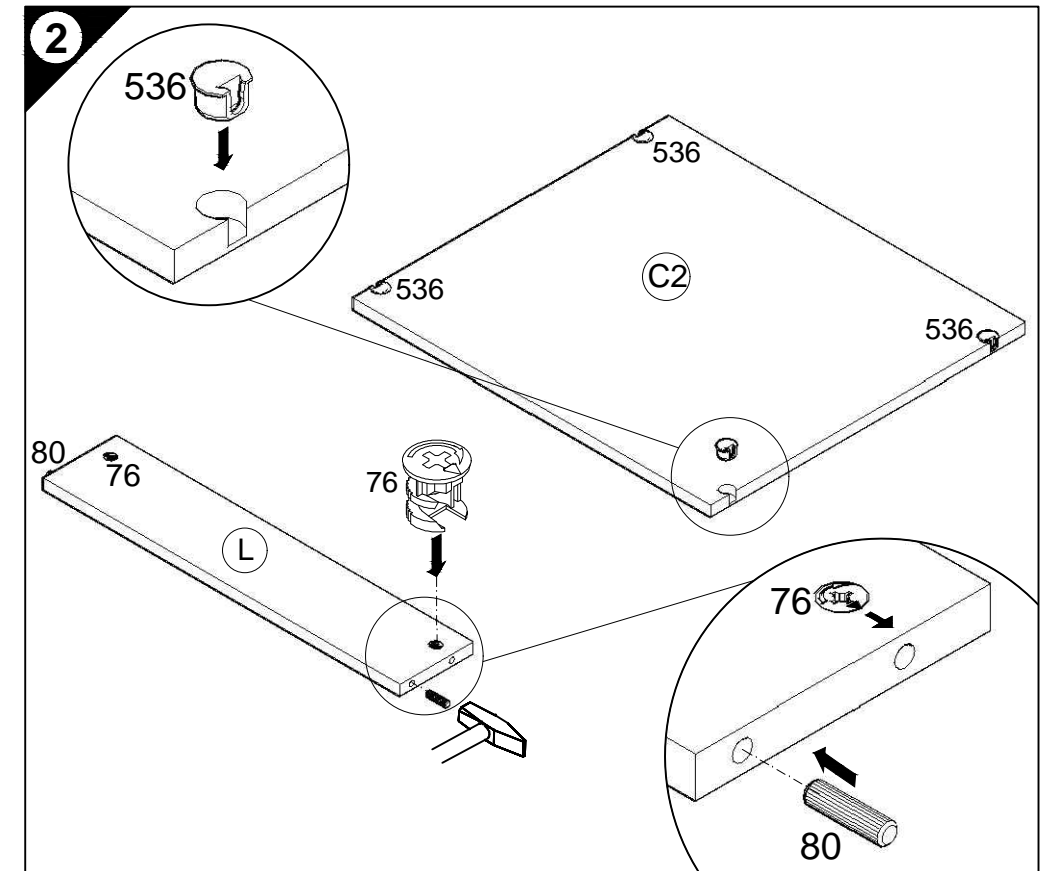
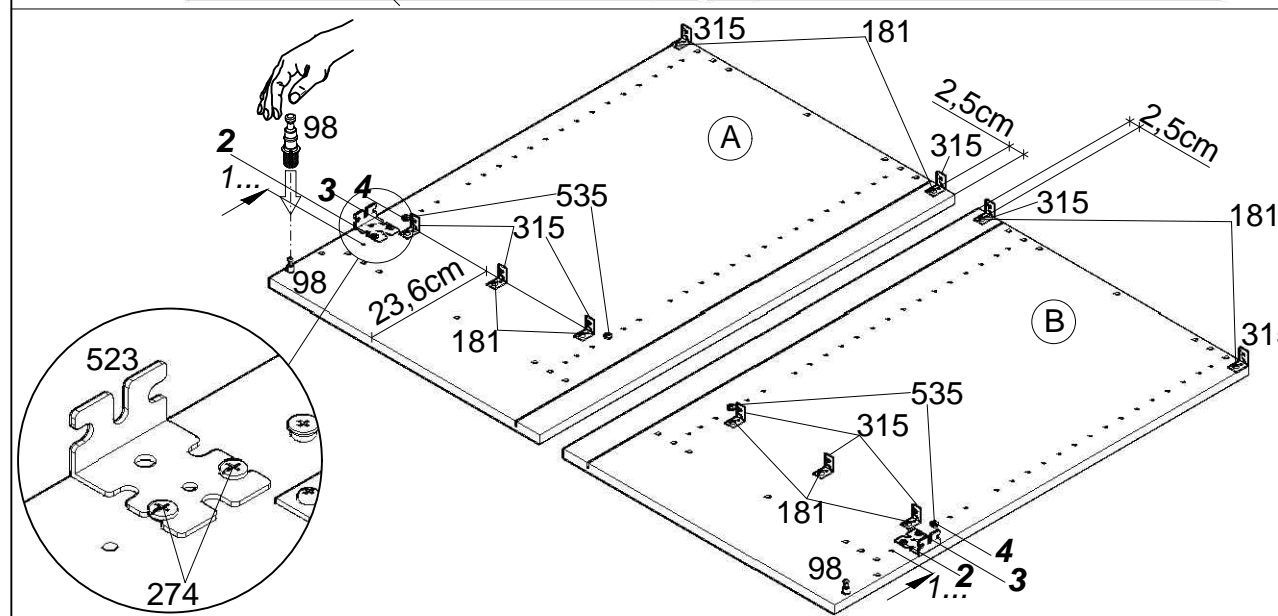
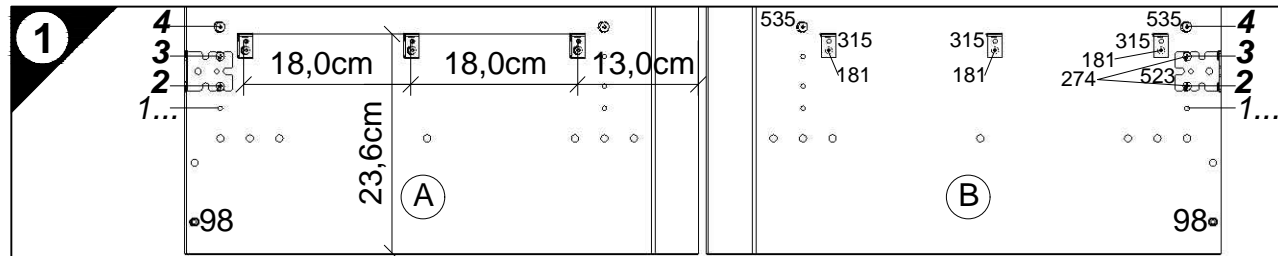
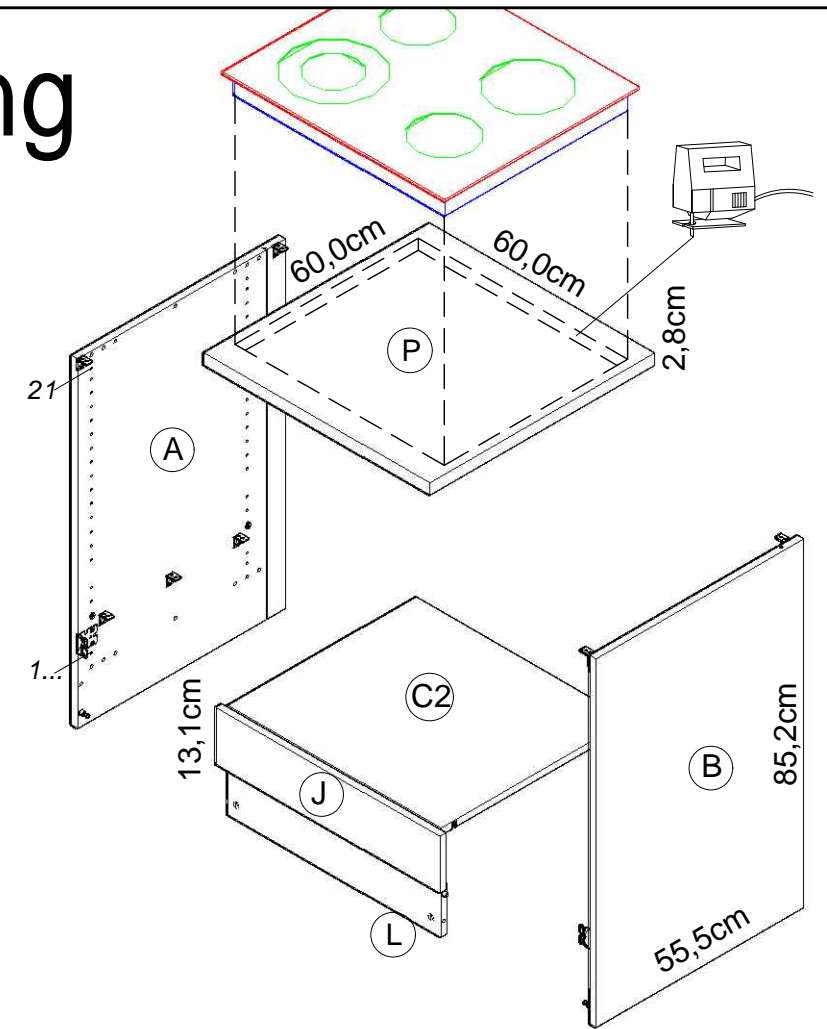

Ersatzteile/Spare parts/pièces de rechange/Reserveonderdelen/Piezas de recambio/Ricambi/Запасные части/Części zamienne/pótalkatrészek/Náhradní části/Nadomestni deli/varaosat/reservdelar/náhradné diely/Utilizați piese de schimb/Yedek parçalar

60cm U634-0	(A) E961033	(B) E961034	(C2) E950223	(J) E940589	(L) E970973	(P) E540103
60cm UO634-0	(A) E961033	(B) E961034	(C2) E950223	(J) E940589	(L) E970973	

1 → 2 → 3 ...

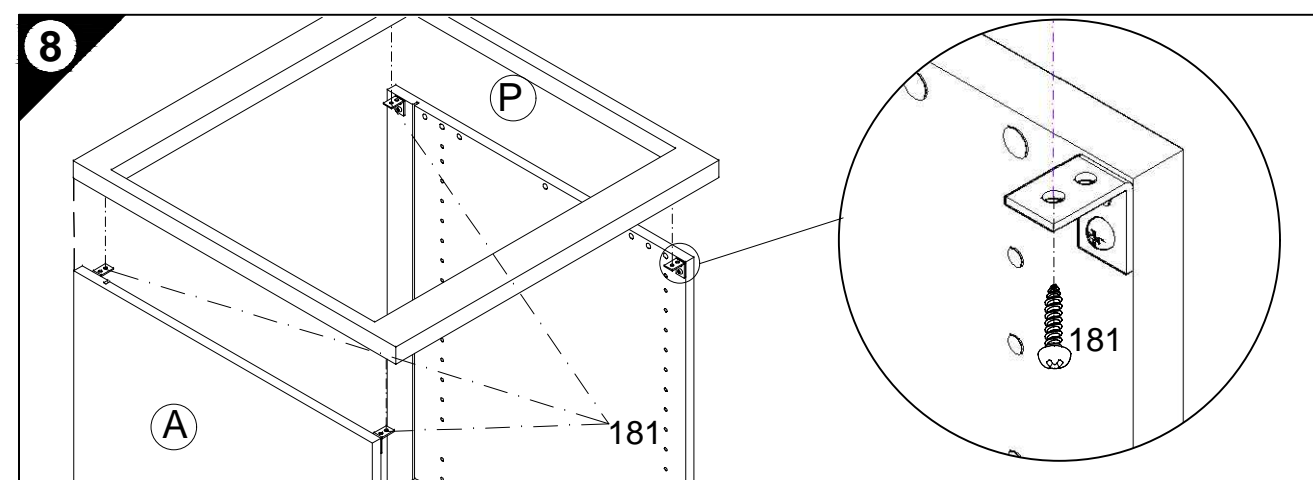
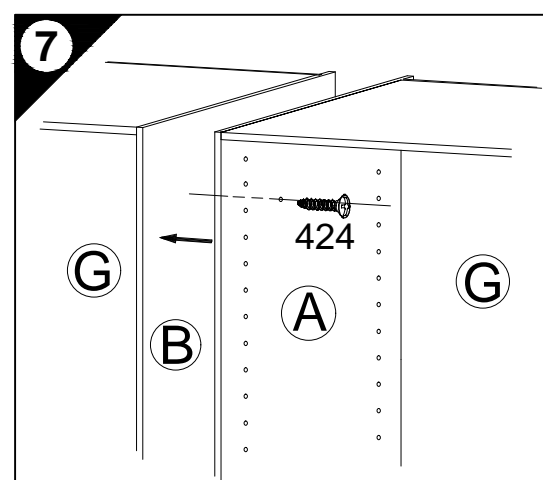
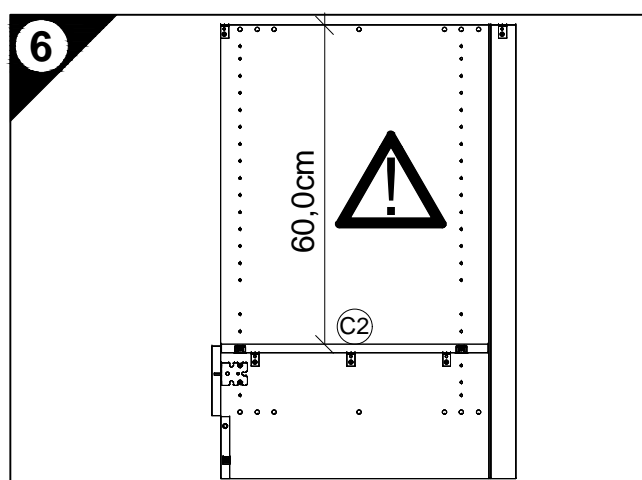
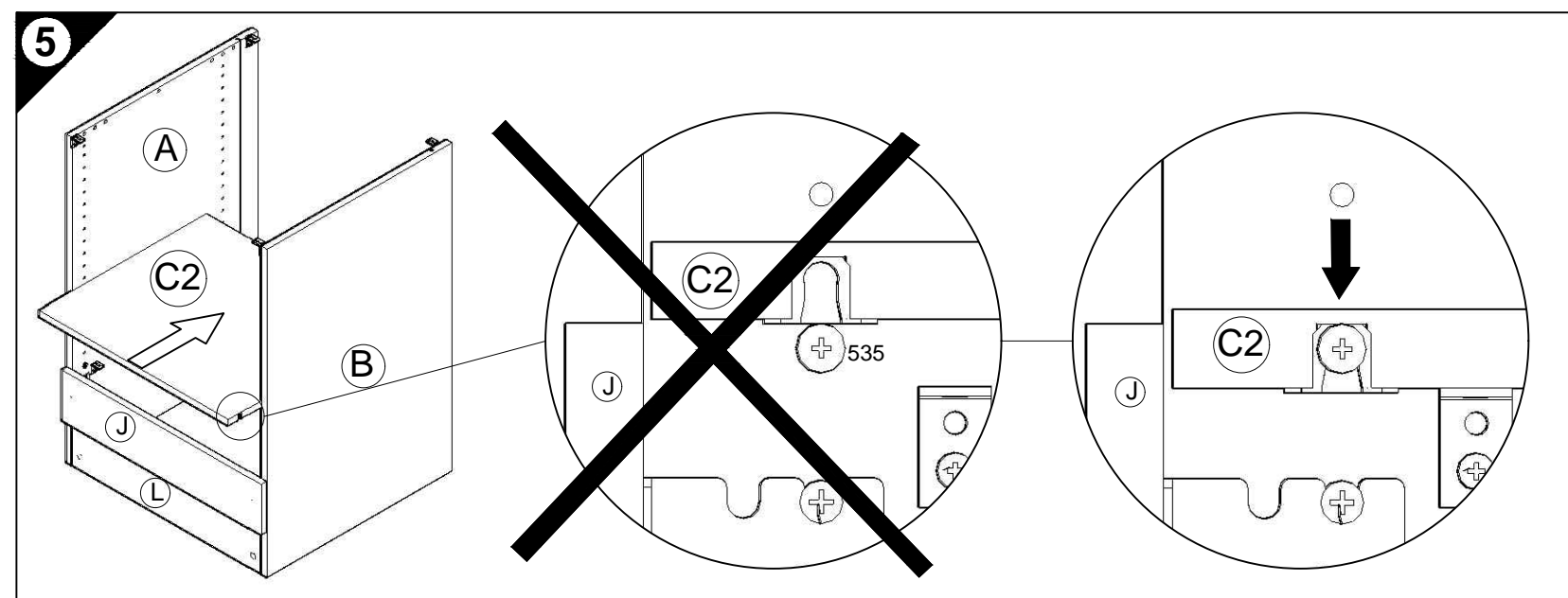
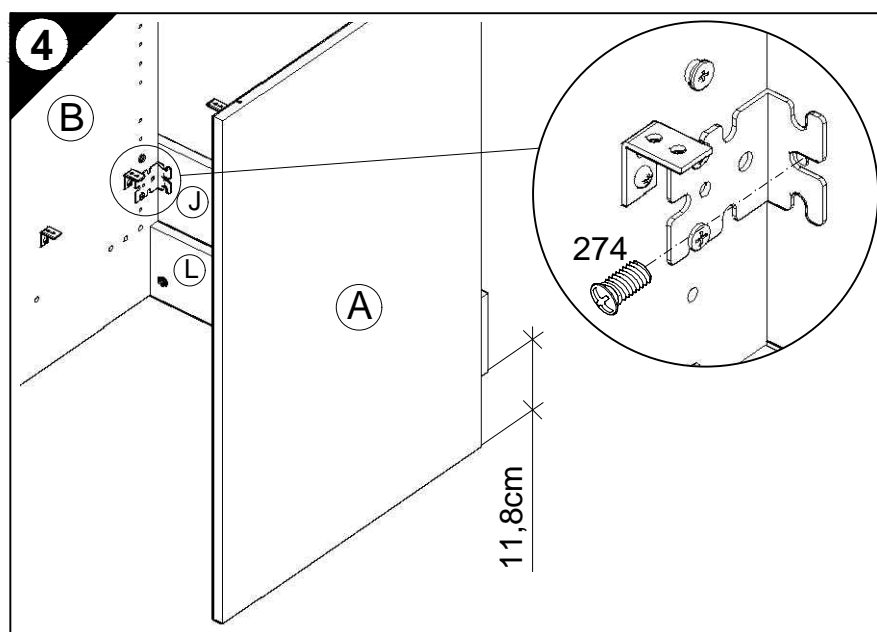
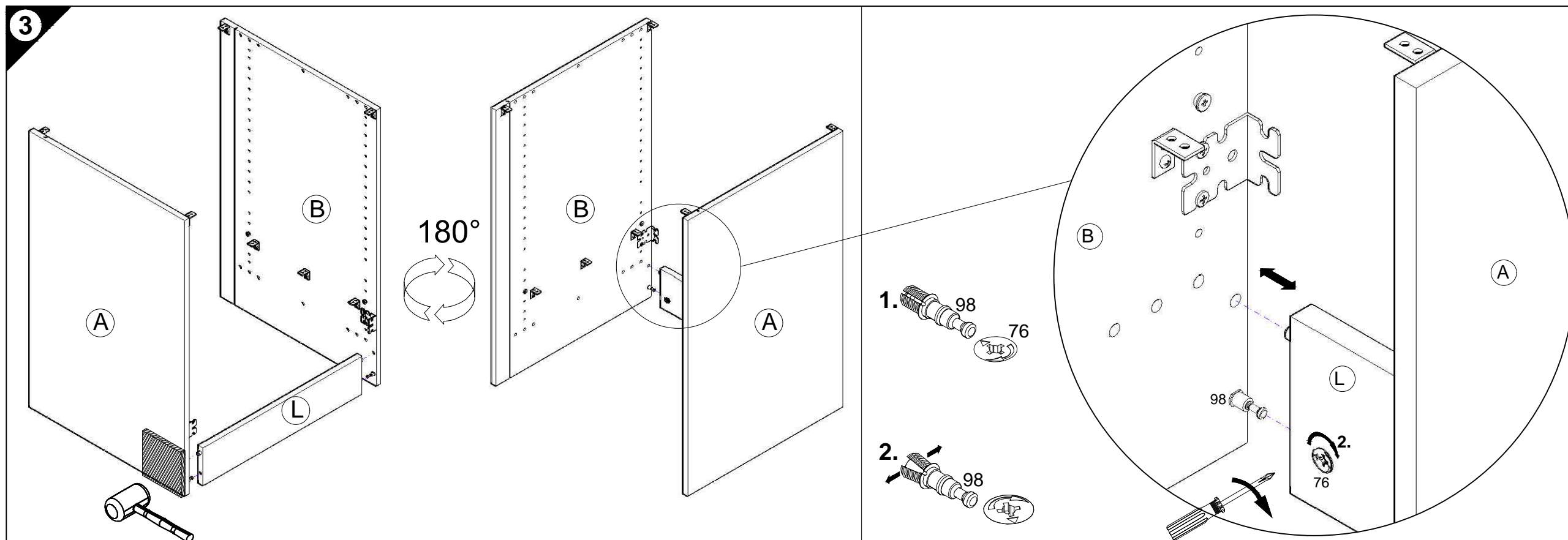
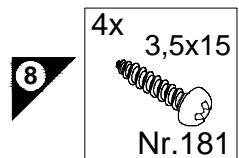
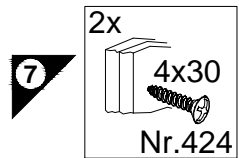
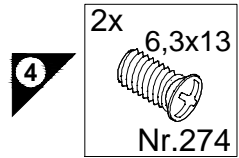

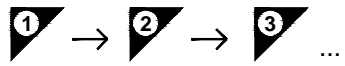
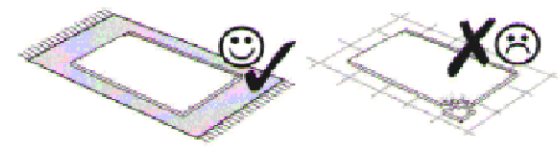
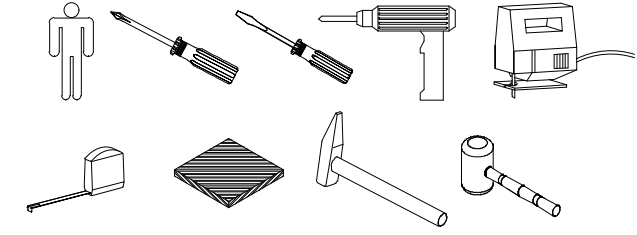

- 1**
- 6x Nr.98
 - 2x Nr.367
 - 2x Nr.523
 - 4x 6,3x13 Nr.274
 - 4x Nr.315
 - 4x 3,5x15 Nr.181
- 2**
- 6x Nr.76
 - 12x Ø8x30 Nr.80
 - 2x Ø5x30 Nr.81
 - 2x Nr.315
 - 2x 3,5x15 Nr.181

Montageanleitung

Service-Hotline
01805-678101
0,14€ pro Minute
++49 für Österreich
Auslandstarif pro Minute
service@jaka-bkl.de
voor Nederland en België
00800-40119350
benelux@jaka-bkl.de

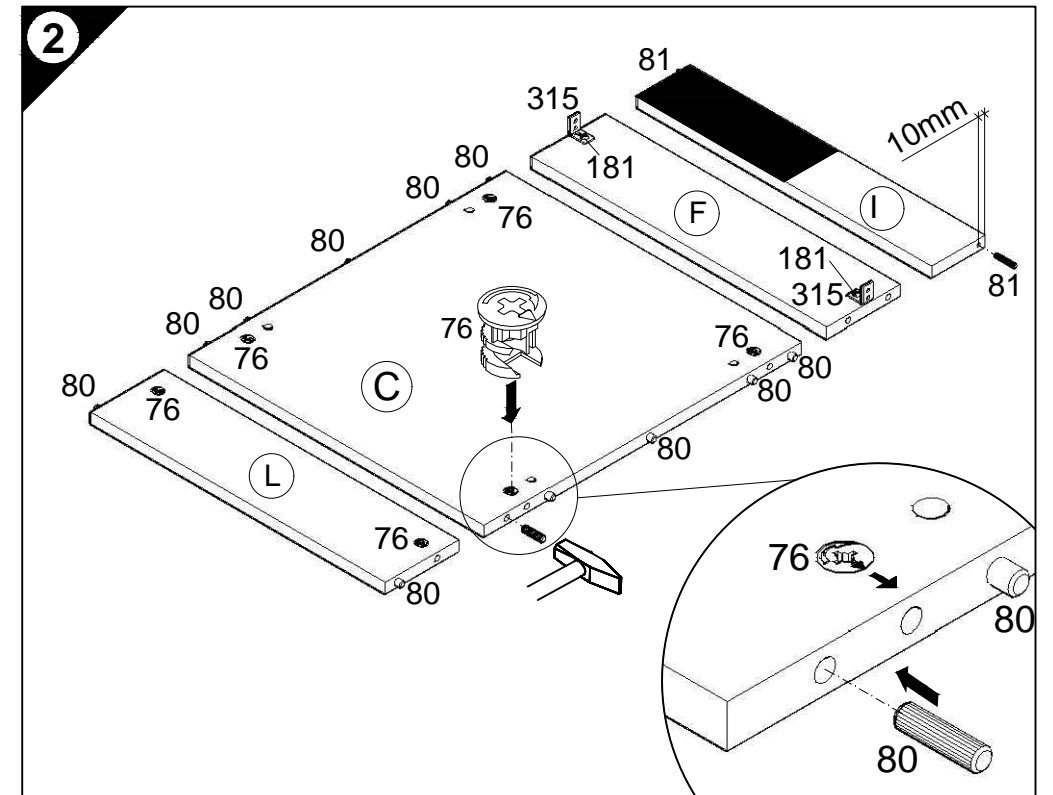
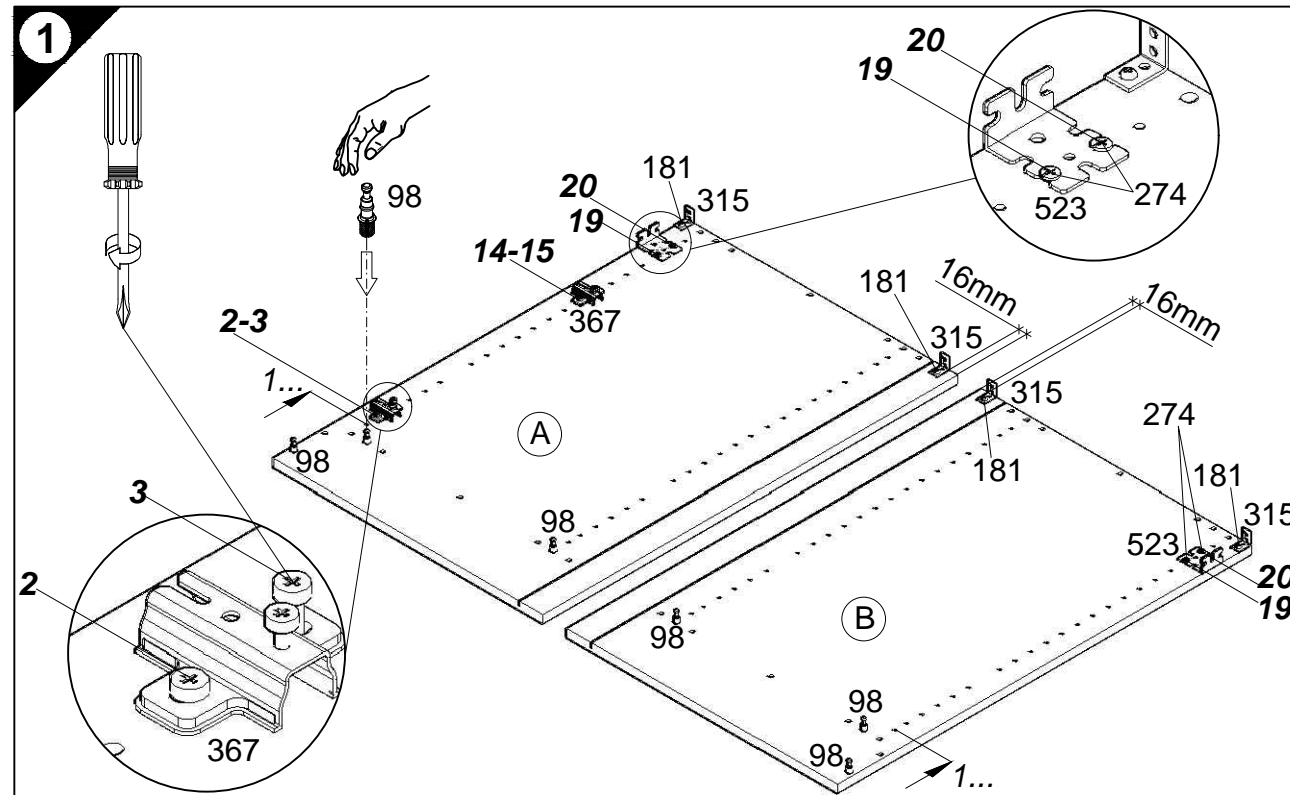
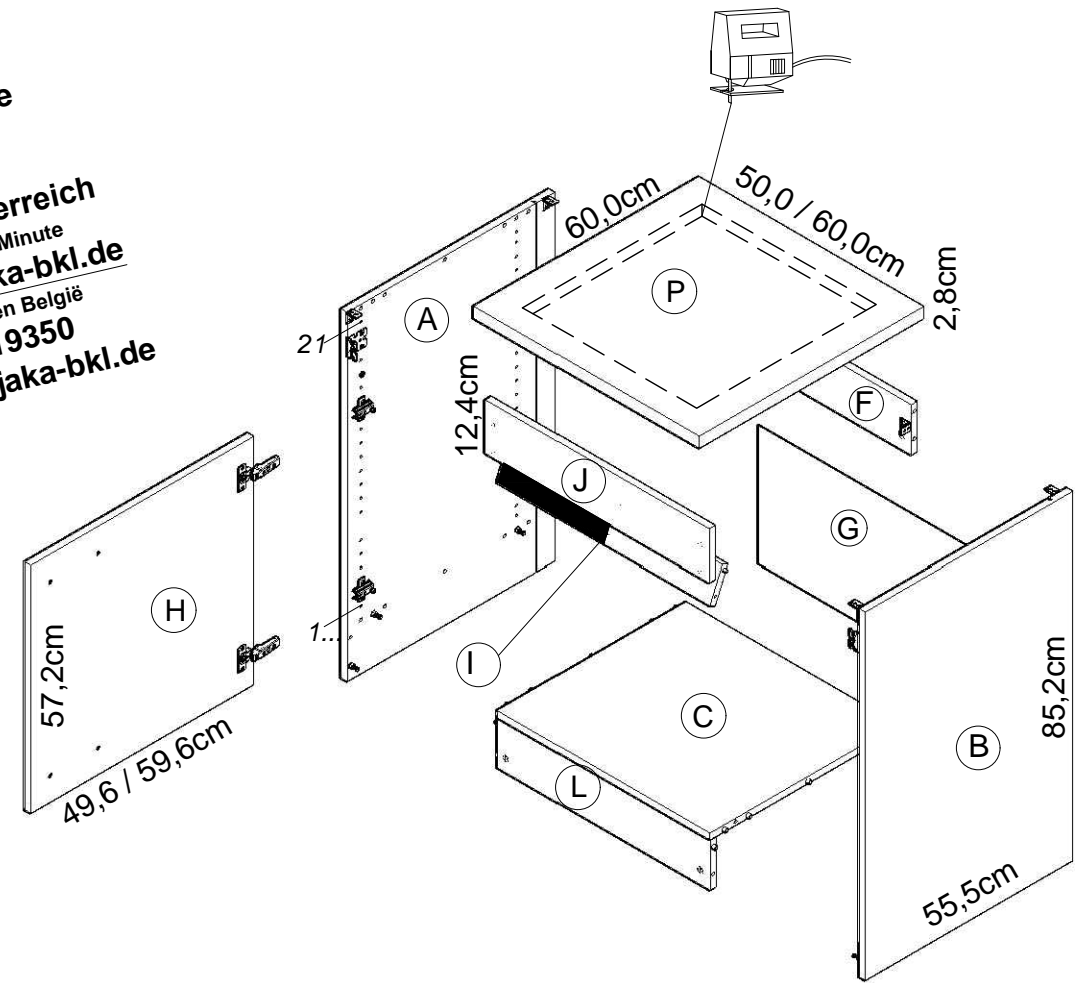
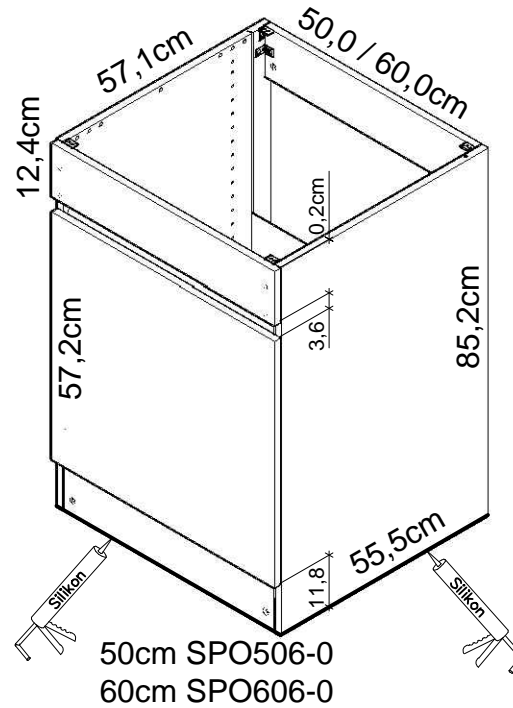
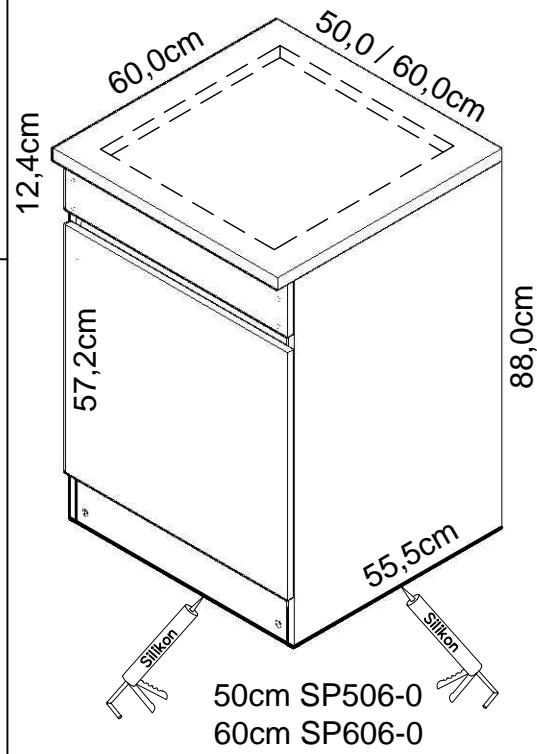

Ersatzteile/Spare parts/pièces de rechange/Reserveonderdelen/Piezas de recambio/Ricambi/Запасные части/Części zamienne/pótalkatrészek/Náhradní části/Nadomestni deli/varaosat/reservdelar/náhradné diely/Utilizați piese de schimb/Yedek parçalar

50cm SP506-0	(A) E961033	(B) E961034	(C) E954224	(F) E970974	(G) E445043	(H) E940612	(I) E970992	(J) E940563	(L) E970974	(P) E540104
50cm SPO506-0	(A) E961033	(B) E961034	(C) E954224	(F) E970974	(G) E445043	(H) E940612	(I) E970992	(J) E940563	(L) E970974	
60cm SP606-0	(A) E961033	(B) E961034	(C) E954223	(F) E970973	(G) E970079	(H) E940611	(I) E970991	(J) E940562	(L) E970973	(P) E540103
60cm SPO606-0	(A) E961033	(B) E961034	(C) E954223	(F) E970973	(G) E970079	(H) E940611	(I) E970991	(J) E940562	(L) E970973	

1 → 2 → 3 ...

