

**RYOBI®**

**RY36BLA**

ORIGINAL INSTRUCTIONS

# 36V Cordless Blower



## IMPORTANT!

It is essential that you read the instructions in this manual before assembling, operating, and maintaining the product.  
Subject to technical modification.

Safety, performance, and dependability have been given top priority in the design of your cordless blower.

## INTENDED USE

The cordless blower is intended only for outdoor use, in dry and well-illuminated conditions.

The product is intended for blowing light debris including leaves, grass, and other garden refuse.

Do not use the product for any other purpose.

## GENERAL SAFETY WARNINGS

**⚠ WARNING!** When using the product, the safety rules must be followed. For your own safety and that of bystanders, you must read and fully understand these instructions before operating the product. Keep these instructions safe for later use.

**⚠ WARNING!** This product is not intended to be used by children or persons with reduced physical, mental, or sensory capabilities. Children should be adequately supervised to ensure that they do not play with the product.

## TRAINING

- Read the instructions carefully. Be familiar with the controls and the correct use of the product.
- Never allow children, persons with reduced physical, sensory or mental capabilities or lack of experience and knowledge, or people who are unfamiliar with these instructions to use the product. Local regulations may restrict the age of the operator.
- Keep in mind that the operator or user is responsible for accidents or hazards occurring to other people or their property.
- Keep bystanders, children and pets 15 m away from the area of operation. Stop the product if anyone enters the area.
- Never use the product while tired, ill or under the influence of alcohol, drugs or medication.

## PREPARATION

- Some regions have regulations that restrict the use of the product to some operations. Check with your local authority for advice.
- While operating the product, always wear substantial footwear and long trousers. Do not operate the product when barefoot or wearing open sandals. Avoid wearing clothing that is loose-fitting or that has hanging cords or ties; they can be caught in moving parts.
- Do not wear loose clothing or jewellery that can be drawn into the air inlet.
- Secure long hair so that it is above shoulder level to prevent entanglement in moving parts.
- Wear hearing protection at all times while operating the product. The product is noisy, and may cause permanent hearing injury if precautions to limit your exposure and to reduce noise are not strictly adhered to.
- Wear full eye protection at all times while operating this product. Wear a full face mask or fully enclosed goggles. Normal spectacles or sun glasses are not adequate protection. Objects can be thrown at high speed by the powerful air jet at any time and may rebound from hard surfaces toward the operator.
- Ensure before each use that all controls and safety devices function correctly. Do not use the product if the OFF switch does not stop the product.
- Before each use, always inspect the housing for damage. Ensure that guards and handles are in place and properly secured.
- Return the product to an authorised service centre to replace damaged or unreadable labels.
- Never operate the product with defective guards or shields, or without safety devices in place.
- Keep all cooling air inlets clear of debris.
- Use rakes and brooms to loosen debris before blowing.
- Clear the work area before each use. Remove all objects such as rocks, broken glass, nails, wires, or string which can be blown a considerable distance by high velocity air.

- Operate the product on a firm, level surface only.

## BATTERY TOOL USE AND CARE

- Recharge only with the charger specified by the manufacturer. A charger that is suitable for one type of battery pack may create a risk of fire when used with another battery pack.
- Use power tools only with specifically designated battery packs. Use of any other battery packs may create a risk of injury and fire
- When battery pack is not in use, keep it away from other metal objects, like paper clips, coins, keys, nails, screws or other small metal objects that can make a connection from one terminal to another. Shorting the battery terminals together may cause burns or a fire.
- Under abusive conditions, liquid may be ejected from the battery; avoid contact. If contact accidentally occurs, flush with water. If liquid contacts eyes, additionally seek medical help. Liquid ejected from the battery may cause irritation or burns.

## OPERATION

- Operate the product only at reasonable hours – not early in the morning or late at night when people might be disturbed.
- Never operate the product in an explosive or dusty atmosphere.
- Avoid using the product in bad weather conditions especially when there is a risk of lightning.
- Do not operate the product in poor lighting. The operator requires a clear view of the work area to identify potential hazards.
- The use of hearing protection reduces the ability to hear warnings (shouts or alarms). The operator must pay extra attention to what is going on in the working area.
- Do not get distracted and always concentrate on the task.
- Operating similar tools nearby increases both the risk of hearing injury and the potential for other persons to enter the working area.
- Keep firm footing and balance. Do not overreach. Overreaching can result in loss of balance.

- Always be sure of the footing on slopes. Walk, never run.

- Keep all parts of the body away from any moving part. Rotating impeller blades can cause severe injury.
- Never run the product without the proper equipment attached.
- Do not modify the product in any way or use parts and accessories which are not recommended by the manufacturer.

⚠ **WARNING!** If the product is dropped, suffers heavy impact, or begins to vibrate abnormally, immediately stop the product and inspect for damage or identify the cause of the vibration. Any damage should be properly repaired or replaced by an authorised service centre.

- To reduce the risk of injury associated with contacting rotating parts, always stop the product, remove the battery pack, and make sure all moving parts have come to a stop:
  - before cleaning or clearing a blockage
  - when leaving the product unattended
  - before installing or removing attachments
  - before checking, maintaining, or working on the product
  - to inspect the product for damage after striking a foreign object
  - if the product starts to vibrate abnormally (inspect immediately)
- Immediately turn off the product and remove the battery pack in the event of accident or breakdown. Do not operate the product again until it has been fully checked by an authorised service centre.

## BLOWER SPECIFIC SAFETY WARNINGS

- Wear a face filter mask in dusty conditions to reduce the risk of injury associated with the inhalation of dust.
- Slightly dampen surfaces in dusty conditions.
- Do not point the blower nozzle in the direction of people or pets.
- Never place objects inside the blower tubes.
- Do not operate the product near open windows.

- Use the full blower nozzle extension so that the air stream can work close to the ground and perform effectively.
- Do not place the product on top of or near loose debris. Debris can be sucked into the intake vent, resulting in possible damage to the product.

### ADDITIONAL BATTERY SAFETY WARNINGS

⚠ **WARNING!** To reduce the risk of fire, personal injury, and product damage due to a short circuit, never immerse the product, battery pack or charger in fluid or allow fluid to flow inside them. Corrosive or conductive fluids, such as seawater, certain industrial chemicals, and bleach or bleach-containing products, etc., can cause a short circuit.

### TRANSPORTATION AND STORAGE

- Stop the product, remove the battery pack, and allow it to cool before storing or transporting.
- Clean all foreign materials from the product. Store the product in a cool, dry, and well-ventilated place that is inaccessible to children. Keep the product away from corrosive agents, such as garden chemicals and de-icing salts. Do not store the product outdoors.
- For transportation in vehicles, secure the product against movement or falling to prevent injury to persons or damage to the product.

### TRANSPORTING LITHIUM BATTERIES

Transport the battery in accordance with local and national provisions and regulations.

Follow all special requirements on packaging and labelling when transporting batteries by a third party. Ensure that no batteries can come in contact with other batteries or conductive materials while in transport by protecting exposed connectors with insulating, non-conductive caps or tape. Do not transport batteries that are cracked or leaking. Check with the forwarding company for further advice.

### MAINTENANCE

⚠ **WARNING!** Use only original manufacturer's replacement parts, accessories, and attachments. Failure to do so can cause possible injury, can contribute to poor performance, and may void the warranty.

⚠ **WARNING!** Servicing requires extreme care and knowledge and should be performed only by a qualified service technician. Have the product serviced by an authorised service centre. When servicing, use only original replacement parts.

- You may make adjustment or repairs that are described in this manual. For other repairs, contact an authorised service agent.
- After each use, clean the product with a soft, dry cloth.
- Check all nuts, bolts, and screws at frequent intervals for proper tightness to ensure that the product is in safe working condition. Any part that is damaged should be properly repaired or replaced by an authorised service centre.
- Bring the product to an authorised service centre to replace damaged or unreadable labels.

### CLEARING A BLOCKAGE

- To reduce the risk of injury associated with contacting moving parts, always turn off the product, remove the battery pack, and make sure that all moving parts have come to a complete stop.
- Remove the blower tubes to inspect for blockage. Clear the tubes if required.
- Reinstall the blower tubes before starting the product.

### KNOW YOUR PRODUCT

See page 7.

1. Turbo boost button
2. Variable speed trigger
3. Handle
4. Blower housing
5. Blower tube
6. Handle adjustment knob

## SYMBOLS ON THE PRODUCT



Read and understand all instructions before operating the product. Follow all warnings and safety instructions.



Do not expose the product to rain or damp conditions.



Wear ear protection.



Wear eye protection.



Beware of thrown or flying objects. Keep all bystanders at least 15 m away.



Rotating Fans. Keep hands and feet out of the openings while the product is running.



Conforms to all regulatory standards in the country in the EU where the product is purchased.



EurAsian conformity mark



Ukrainian mark of conformity



Guaranteed sound power level



Waste electrical products should not be disposed of with household waste. Please recycle where facilities exist. Check with your Local Authority or retailer for recycling advice.

## SYMBOLS IN THIS MANUAL



Note



Warning



Parts or accessories are sold separately

**RY36BLA**

**RY36BLA-140**



**x 1**



**x 1**

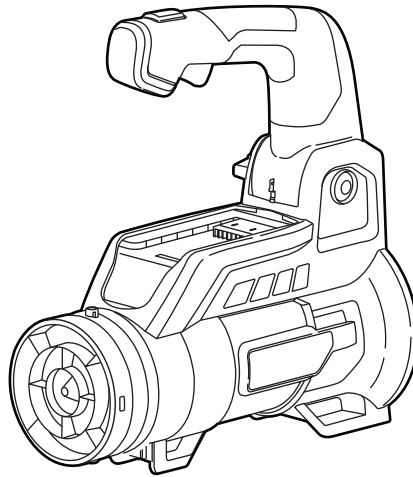

**x 1**

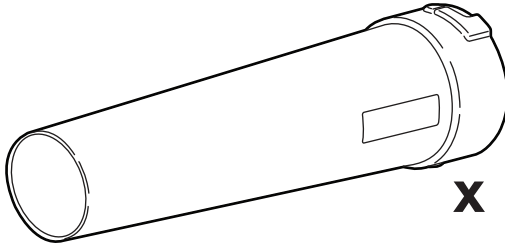

**x 1**



**x 1**

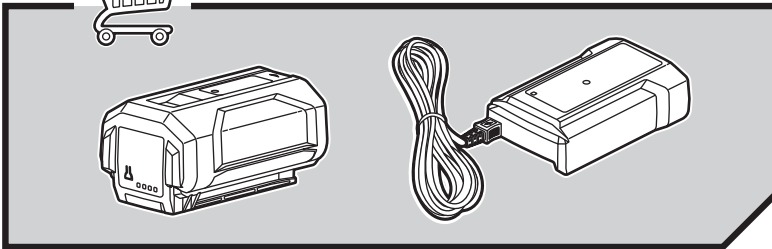

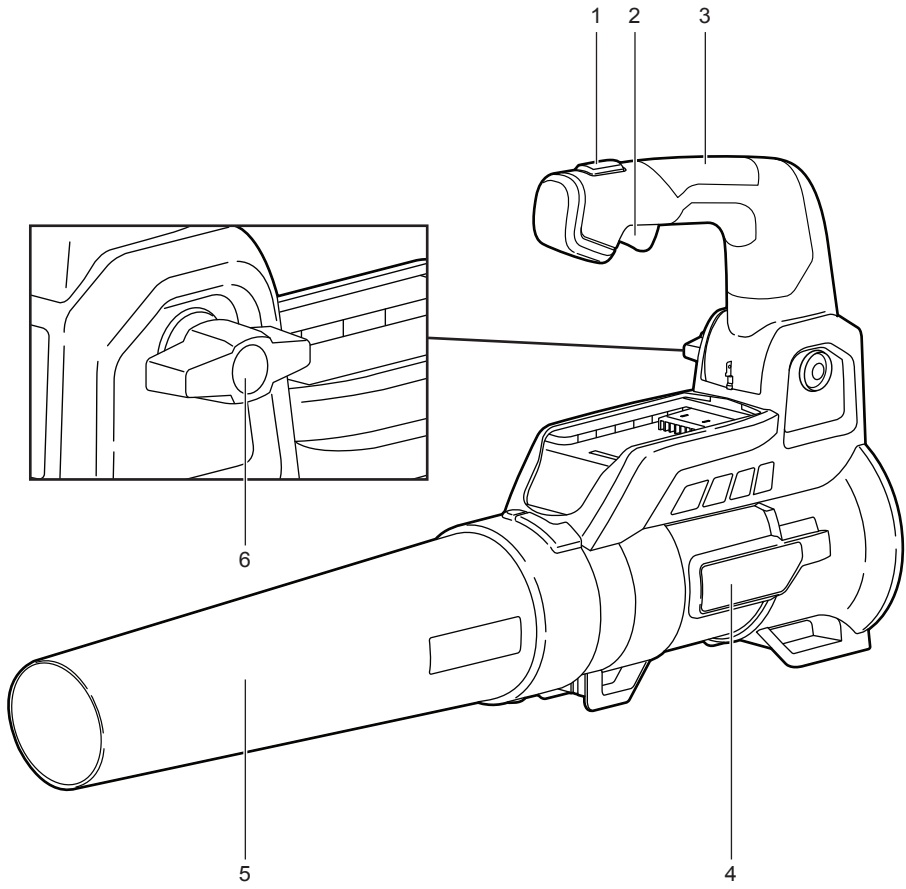

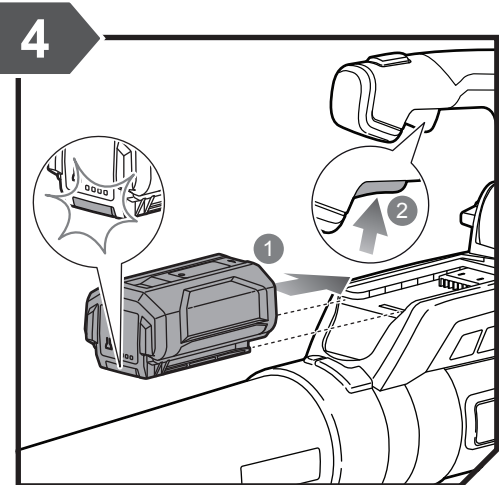
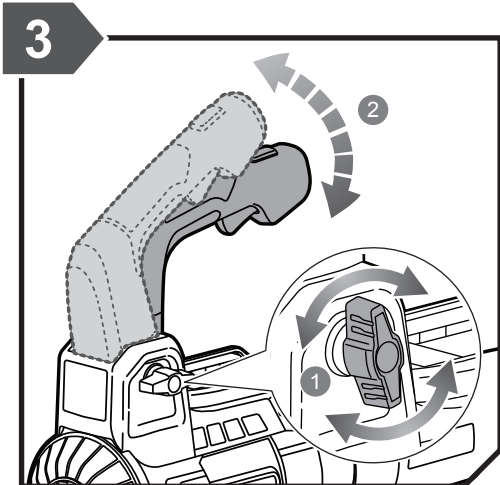
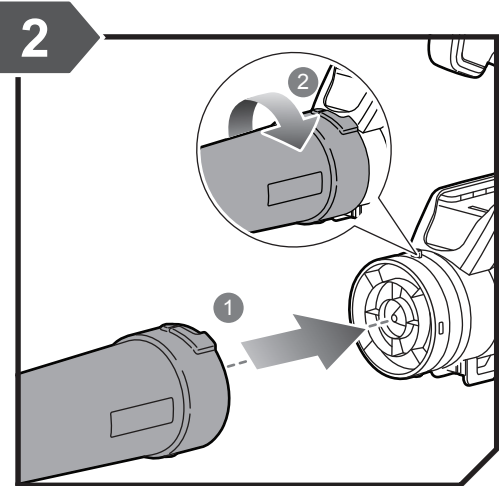
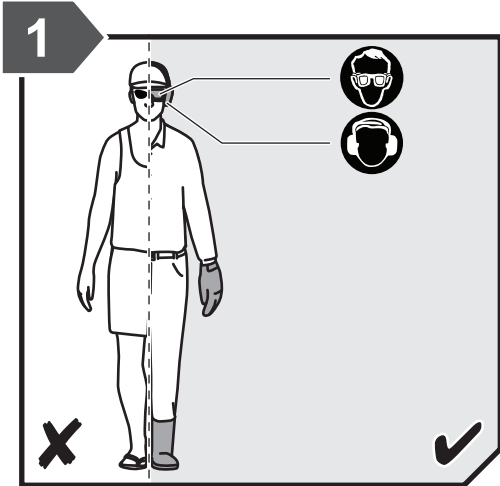



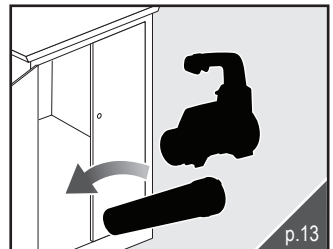
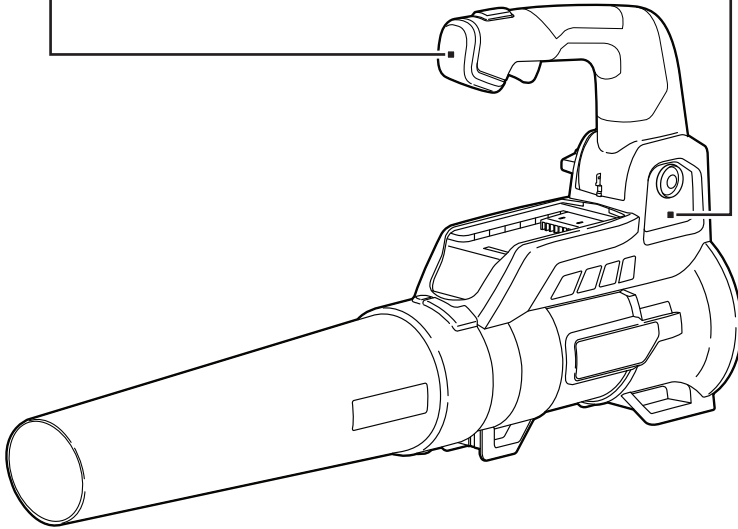
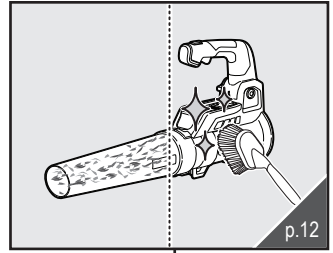
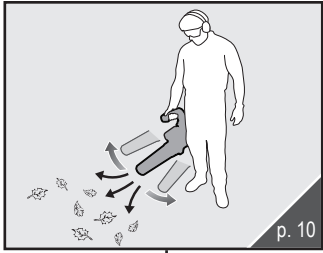

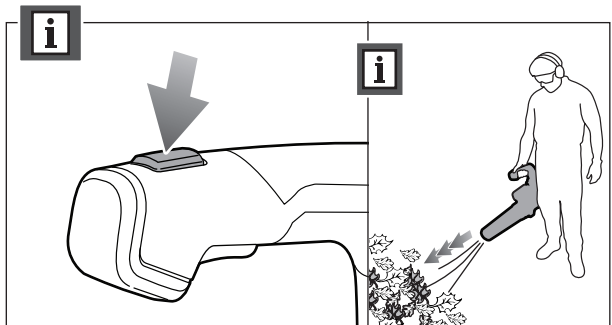
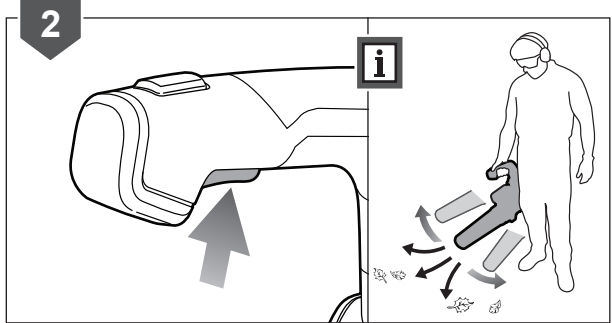
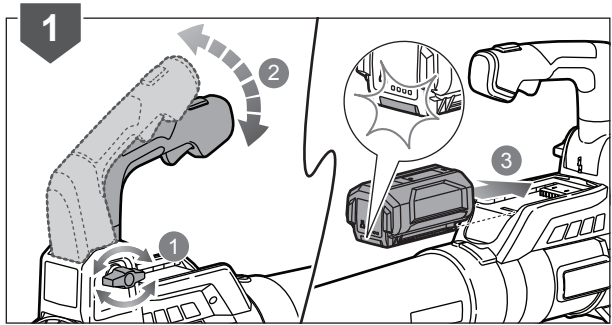
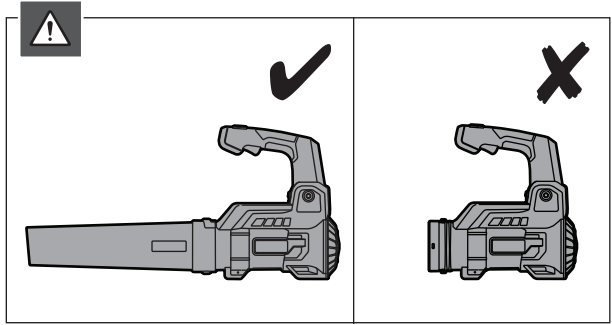
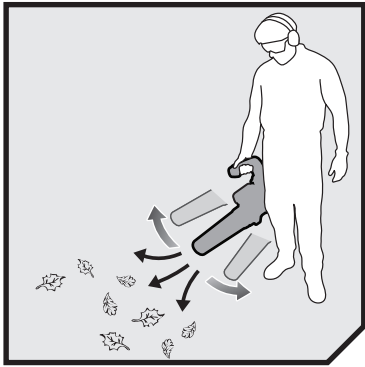

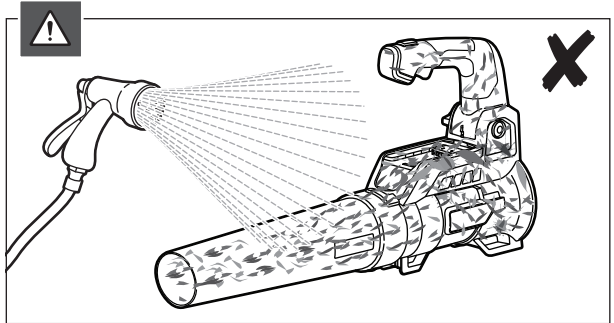
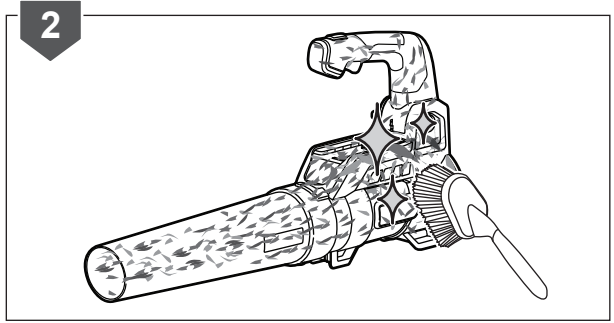
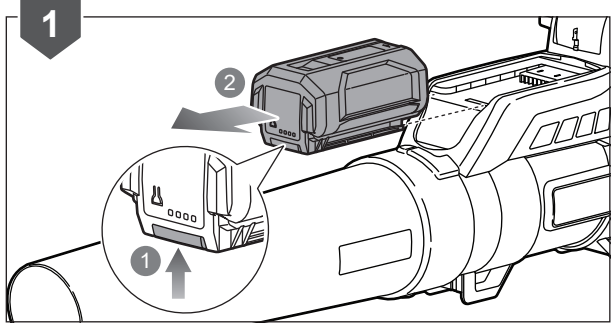
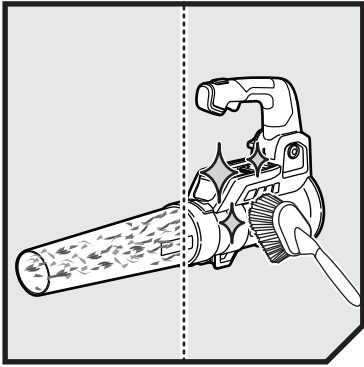

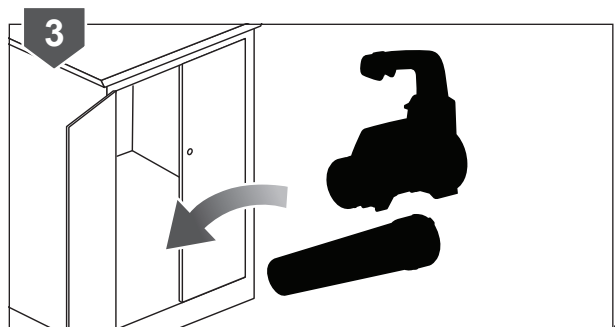
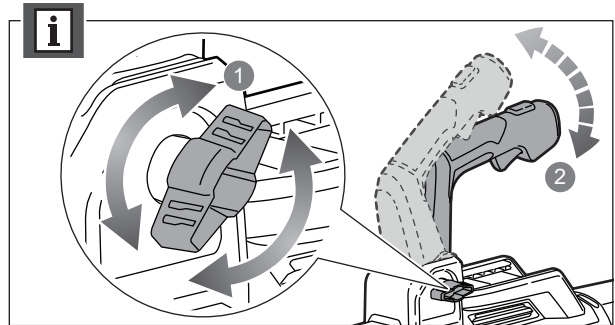
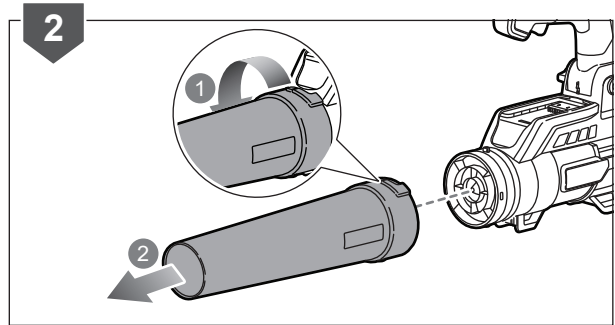
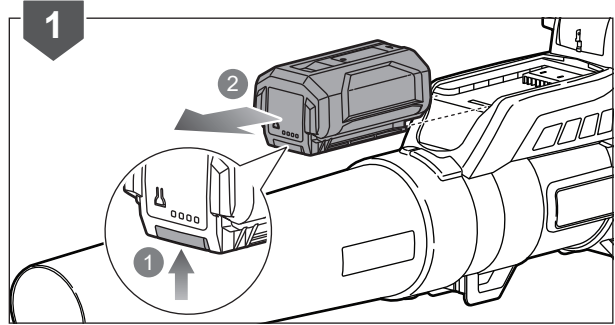
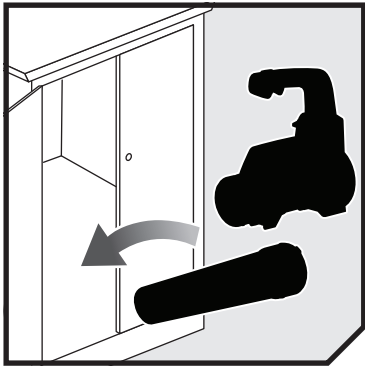

## PRODUCT SPECIFICATIONS

Cordless Blower	
Model	RY36BLA
Rated voltage	36V d.c.
Air Velocity	
High speed	120 km/h
Turbo speed	152 km/h
Air Volume	
High speed	11.80 m <sup>3</sup> /min
Turbo speed	14.86 m <sup>3</sup> /min
Weight (without battery)	2.9 kg
Weight (with heaviest battery)	5.7 kg
Vibration level (in accordance with Annex BB of EN 50636-2-100)	
Vibration level ah	1.0 m/s <sup>2</sup>
K	1.2 m/s <sup>2</sup>
Noise emission level (in accordance with Annex CC of EN 50636-2-100 Annex CC)	
A-weighted sound pressure level at the operator's position $L_{pA}$	90.6 dB(A)
K	3.0 dB
A-weighted sound power level $L_{WA}$	100.6 dB(A)
$K_{WA}$	2.9 dB
$L_{WA} + K_{WA}$	104 dB(A)

## BATTERY AND CHARGER

Model	RY36BLA-0	RY36BLA-140
Battery pack	not included	BPL3640D2
Weight	-	
Charger	not included	RY36C17A
Compatible battery pack	BPL36..., RY36B...	
Compatible charger	BCL36..., RY36C...	

**WARNING!** The declared vibration total values and the declared noise emission values given in this instruction manual have been measured in accordance with a standardised test and may be used to compare one tool with another. They may be used for a preliminary assessment of exposure.

The declared vibration and noise emission values represent the main applications of the tool. However, if the tool is used for different applications, used with different accessories, or poorly maintained, the vibration and noise emission may differ. These conditions may significantly increase the exposure levels over the total working period.

An estimation of the level of exposure to vibration and noise should take into account the times when the tool is turned off or when it is running idle. These conditions may significantly reduce the exposure level over the total working period.

Identify additional safety measures to protect the operator from the effects of vibration and noise, such as maintaining the tool and the accessories, keeping the hands warm (in case of vibration), and organising work patterns.

## RYOBI® WARRANTY APPLICATION ONDITIONS

In addition to any statutory rights resulting from the purchase, this product is covered by a warranty as stated below.

- The warranty period is 24 months for consumers and commences on the date the product was purchased. This date has to be documented by an invoice or other proof of purchase. The product is designed and dedicated to consumer and private use only. So there is no warranty provided in case of professional or commercial use. This warranty applies only on new products.
- There is a possibility to extend for a part of the range of power tools (AC/DC) the warranty period over the period described above using the registration on the [www.ryobitools.eu](http://www.ryobitools.eu) website. The eligibility of products for extended warranty is clearly displayed in stores and / or on packaging and is contained within the product documentation. The end user is required to register his/her newly-acquired products online within 30 days from the date of purchase. The end user may register for the extended warranty in his/her country of residence if listed on the online registration form where this option is valid. Furthermore, end users must give their consent to the storage of their personal data that is required to be entered online. They must also accept the terms and conditions. The registration confirmation receipt, which is sent out by e-mail, and the original invoice showing the date of purchase will serve as proof of the extended warranty.
- The warranty covers all defects of the product during the warranty period due to faults in workmanship or material at the purchase date. The warranty is limited to repair and/or replacement and does not include any other obligations including but not limited to incidental or consequential damages. The warranty is not valid if the product has been misused, used contrary to the instruction manual, or has been incorrectly connected to a power supply. This warranty does not apply to:
  - any damage to the product that is the result of improper or lack of maintenance
  - any product that has been altered or modified
  - any product where original identification (trade mark, serial number) markings have been defaced, altered or removed
  - any damage caused by non-observance of the instruction manual
  - any product not displaying the CE approval mark on the rating plate
  - any product that has been attempted to be repaired by a non-authorized warranty service centre or without prior authorisation by Techtronic Industries
  - any product connected to an improper power supply (amps, voltage, frequency)
  - any product used with inappropriate fuel mixture (fuel, oil, Ratio of oil / fuel mixture)
  - any damage caused by external influences (water, chemical, physical, shocks) or foreign substances
  - normal wear and tear spare parts
  - inappropriate use, overloading of the tool
  - use of non-approved accessories or parts
  - Accessories provided with the tool or purchased separately including but not limited to blades, saw chains, cutting lines etc.
  - Any periodic adjustments to or maintenance cleaning of carburetors
  - Components (parts and accessories) subject to natural wear and tear, including but not limited to bump knobs, drive belts, clutch, blades of hedge trimmers or lawn mowers, harness, cable throttle, carbon brushes, power cord, tines, felt washers, hitch pins, blower fans, blower and vacuum tubes, vacuum bag and straps, guide bars, saw chains, hoses, connector fittings, spray nozzles, wheels, spray wands, inner reels, outer spools, cutting lines, spark plugs, air filters, gas filters, mulching blades, etc.
- For servicing, the product must be sent or presented to a RYOBI authorised service station listed for each country in the following list of service station addresses. In some countries your local RYOBI dealer undertakes to send the product to the RYOBI service organisation. When sending a product to a RYOBI service station, the product should be safely packed without any dangerous contents such as petrol, marked with sender's address and accompanied by a short description of the fault.
- A repair / replacement under this warranty is free of charge. It does not constitute an extension or a new start of the warranty period. Exchanged parts or products become our property. In some countries delivery charges or postage will have to be paid by the sender. Your statutory rights arising from the purchase of the product remain unaffected.
- This warranty is valid in the European Community, Switzerland, Iceland, Norway, Liechtenstein, Turkey and Russia. Outside these areas, please contact your authorised RYOBI dealer to determine if another warranty applies.

## AUTHORISED SERVICE CENTRE

Any request or issue with the product can be addressed to your local authorized service centres (visit [www.ryobitools.eu](http://www.ryobitools.eu)) or directly to: Techtronic Industries GmbH, Max Eyth Straße 10, 71364 Winnenden, Germany. Please state the serial number and product type printed on the label.

## DECLARATION OF CONFORMITY

Techtronic Industries GmbH  
Max-Eyth-Straße 10, 71364 Winnenden, Germany

Hereby we declare that the product

Cordless Blower  
Brand: RYOBI  
Model number: RY36BLA  
Serial number range: 47538401000001 - 47538401999999

is in conformity with the following European Directives and harmonized standards  
2006/42/EC, 2014/30/EU, 2000/14/EC, 2005/88/EC, 2011/65/EU,  
EN 60335-1:2012+A11:2014+A13:2017+A1:2019+A14:2019+A2:2019,  
EN 50636-2:100:2014, EN 55014-1:2017, EN 55014-2:2015, EN IEC  
63000:2018, EN ISO 12100:2010

Measured sound power level: 100.6 dB(A)  
Guaranteed sound power level: 104 dB(A)

Conformity assessment method to Annex V  
Directive 2000/14/EC amended by 2005/88/EC.



Todd Chipper  
Sr. Director, CPT Quality and Asia Regulatory & Safety  
Winnenden, Sep. 3, 2020

Authorised to compile the technical file:  
Alexander Krug, Managing Director  
Techtronic Industries GmbH  
Max-Eyth-Straße 10, 71364 Winnenden, Germany

*RYOBI is a trade mark of Ryobi Limited,  
and is used under license.  
© 2020 Techtronic Cordless GP.*





**Techtronic Industries GmbH**  
Max-Eyth-Straße 10,  
71364 Winnenden, Germany

961087239-01