

Instrucciones de montaje

Pitarch
SYSTEM KIT MUEBLES

Assembly instructions



REF. 1107 // 6107

Te aconsejamos / We advise you

Ordena y cuenta las piezas y herrajes

Habilita una zona para el montaje

Utiliza la caja de embalaje desplegada como superficie de apoyo

No fuerces los tornillos y los elementos de montaje

Sigue paso a paso las instrucciones de montaje

Order and count the parts and fittings

Enable an area for assembling.

Do not force the screws or assembly parts

Follow the assembly instructions step by step

Herramientas necesarias Tools required

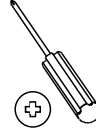
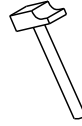
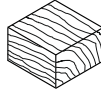

Cinta americana
Scotch tape

Herrajes incluidos / Fittings included

| | | | |
|------------------------------------|---------------------------------------|---------------------------------|-----------------------------------|
| <p>Carr x 4</p> <p>Nº710152</p> | <p>Exc x 4</p> <p>Nº721016 721017</p> | <p>Lzgr x 1</p> <p>Nº721034</p> | <p>Autgr x 10</p> <p>Nº721002</p> |
| <p>Tirn x 2</p> <p>Nº722034_35</p> | <p>Tac x 4</p> <p>Nº721045</p> | <p>Pun x 30</p> <p>Nº720006</p> | <p>Rei x 8</p> <p>Nº721020</p> |
| <p>Pem x 8</p> <p>Nº721036</p> | <p>Sali x 4</p> <p>710004</p> | <p>Rued x 4</p> <p>710003</p> | |

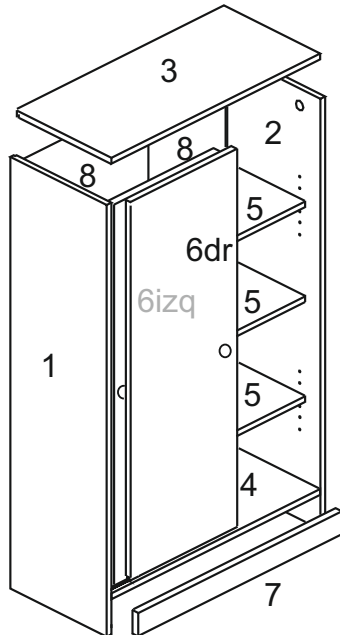

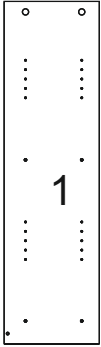

1169x325 mm
110715/610715

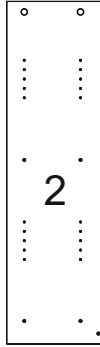

1169x325 mm
110714/610714



742x326 mm
110731/610731



708x324 mm
110732/610732

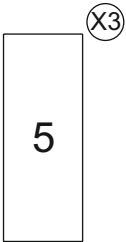

708x270 mm
354420

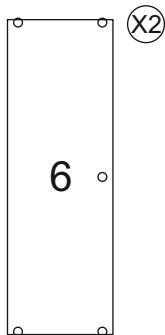

1075x360 mm
110740/610740



708x70 mm
110770/610770

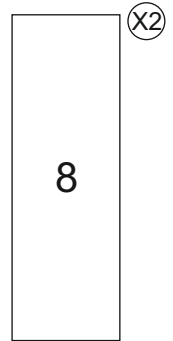

1112x368 mm
9354475

1

Carr x 2

Exc x 4

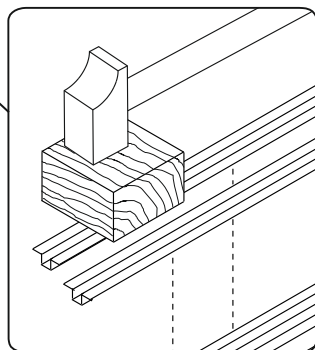
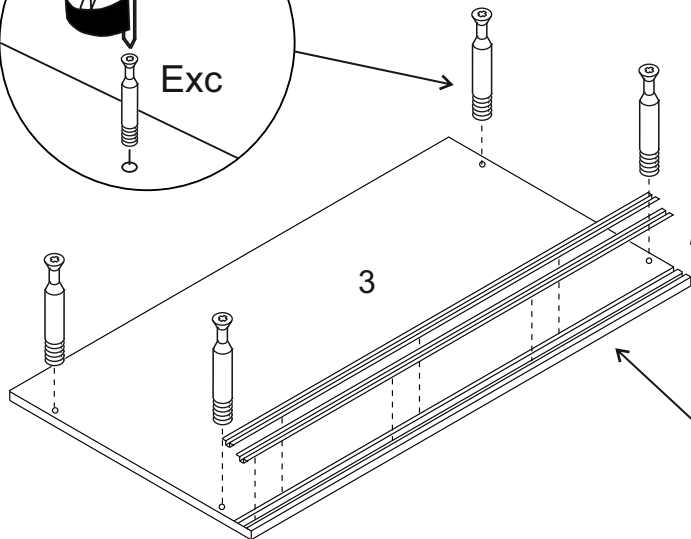
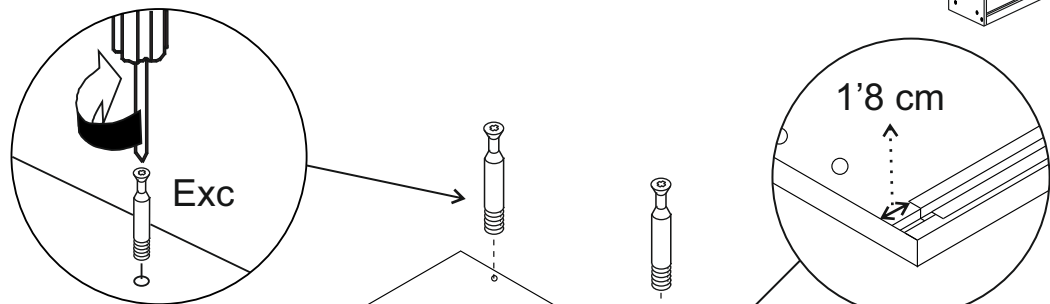
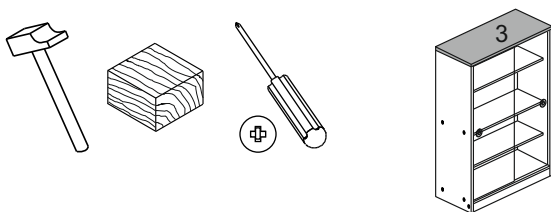

Carr x 2

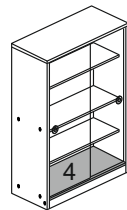
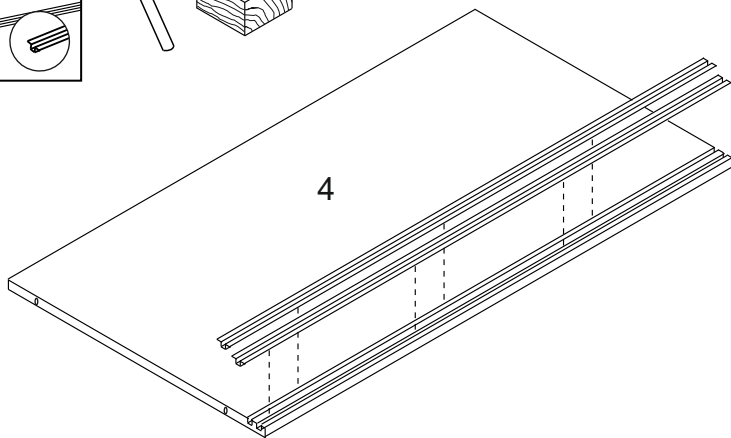
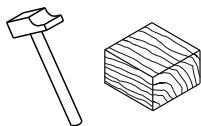

| | | | |
|---|----------|------------|---------|
| 2 | Lzgr x 1 | Autgr x 10 | Tac x 4 |
|---|----------|------------|---------|

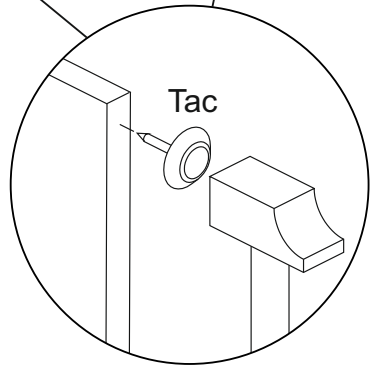
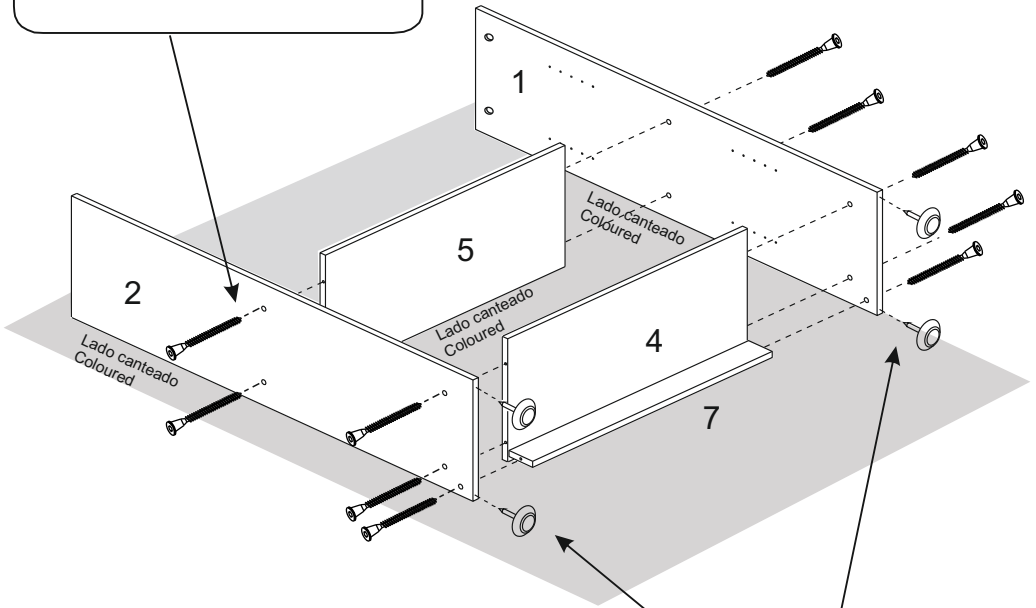
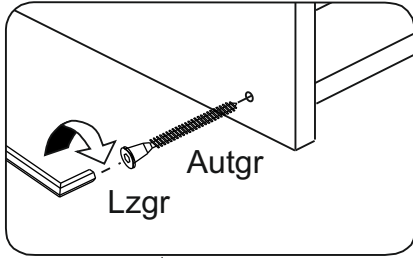
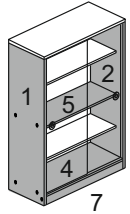
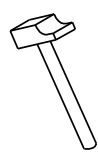

3

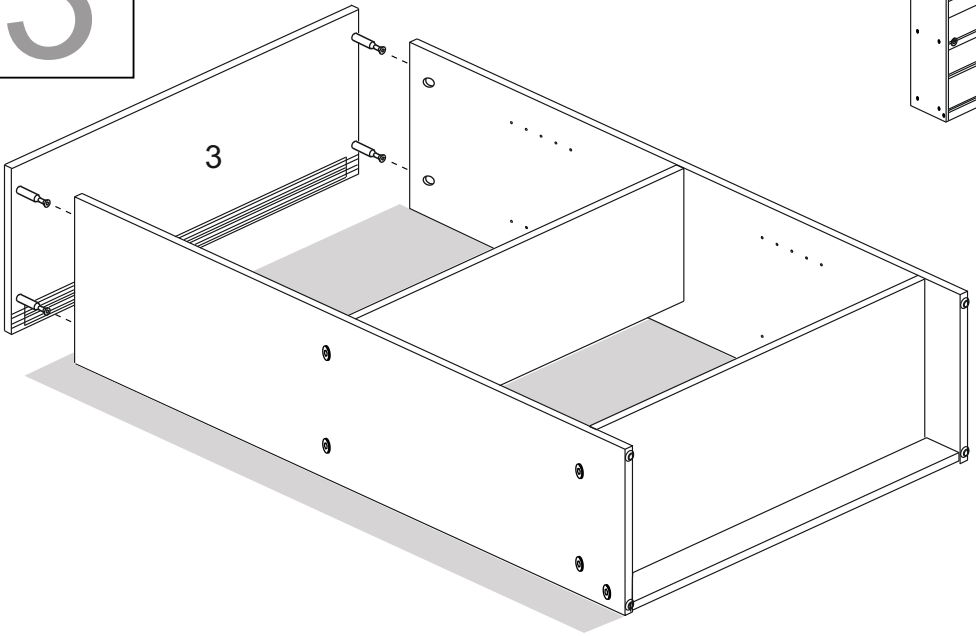
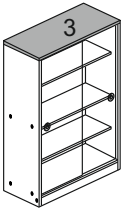

4

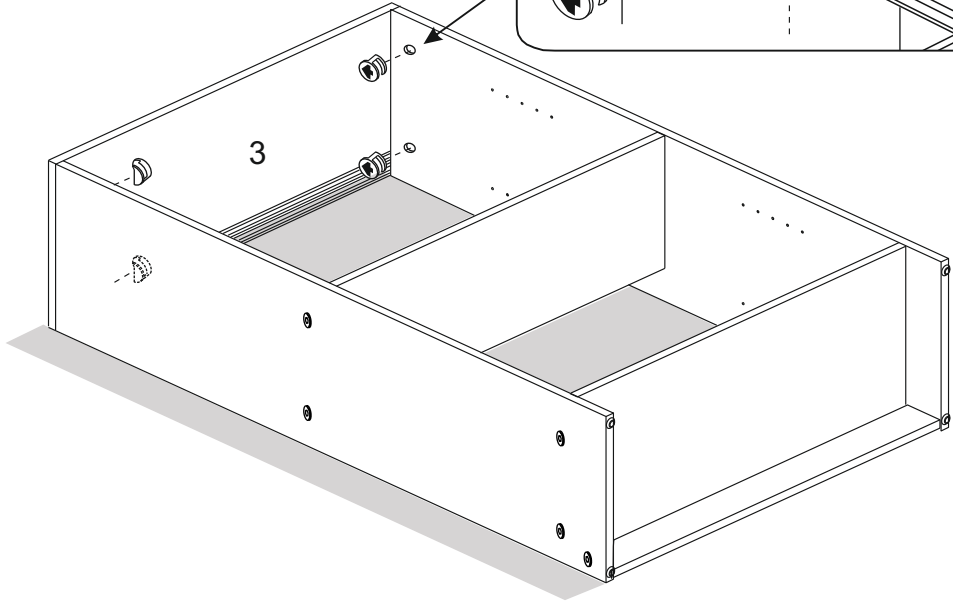
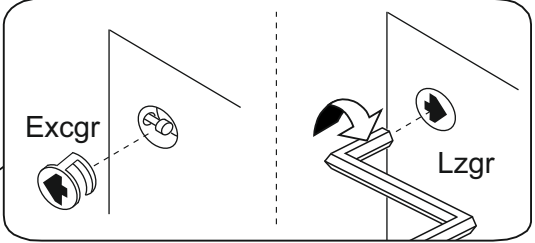
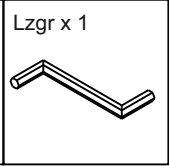
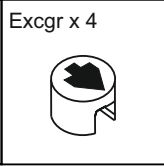

5 Pun x 30



Cinta americana
Scotch tape

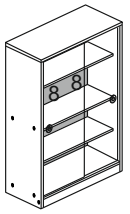
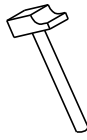
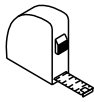



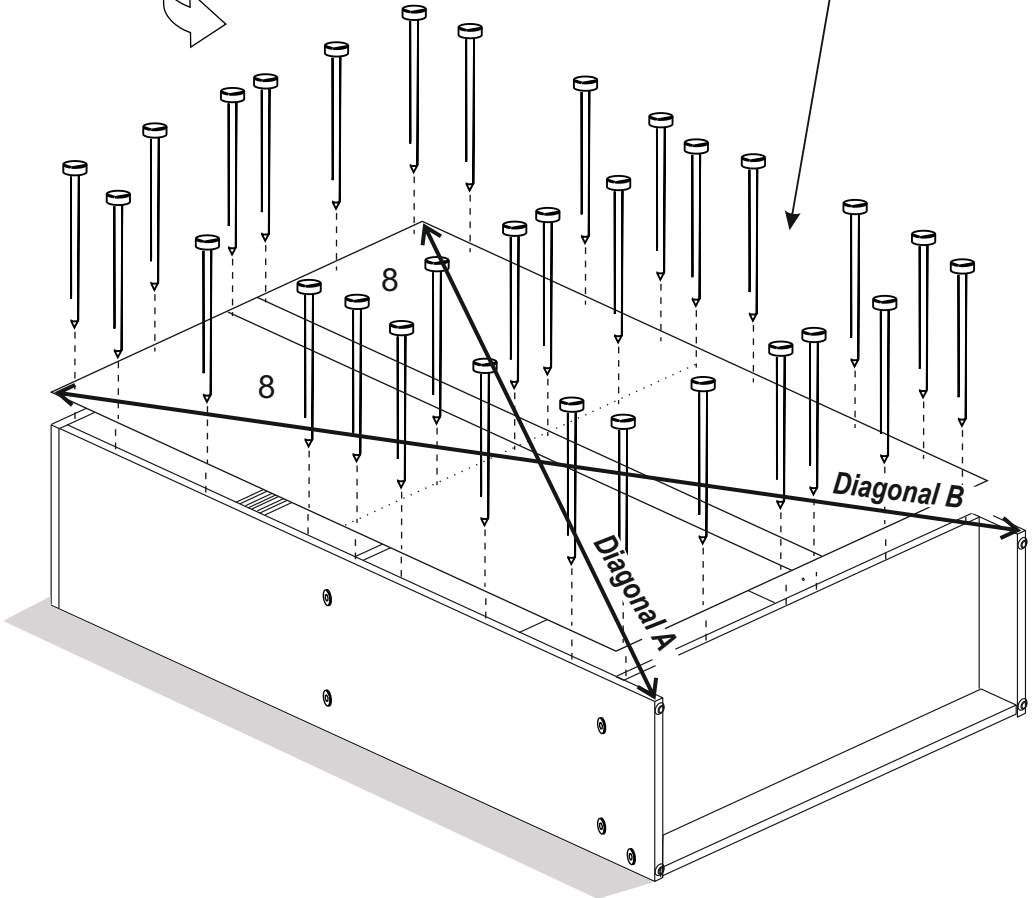
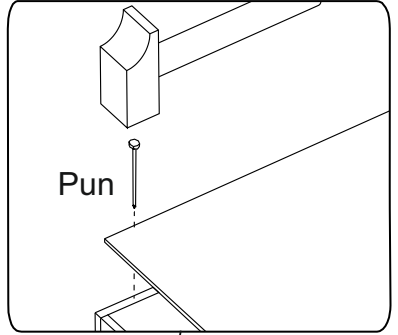
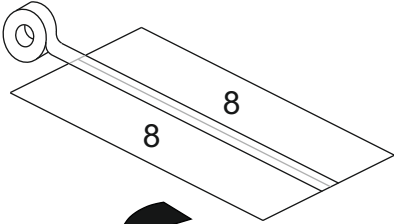

Diagonal A = Diagonal B

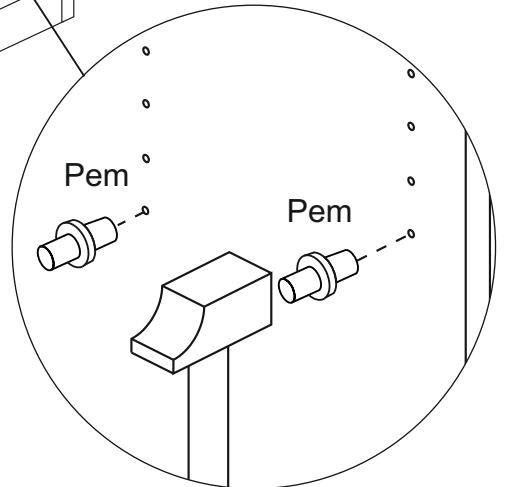
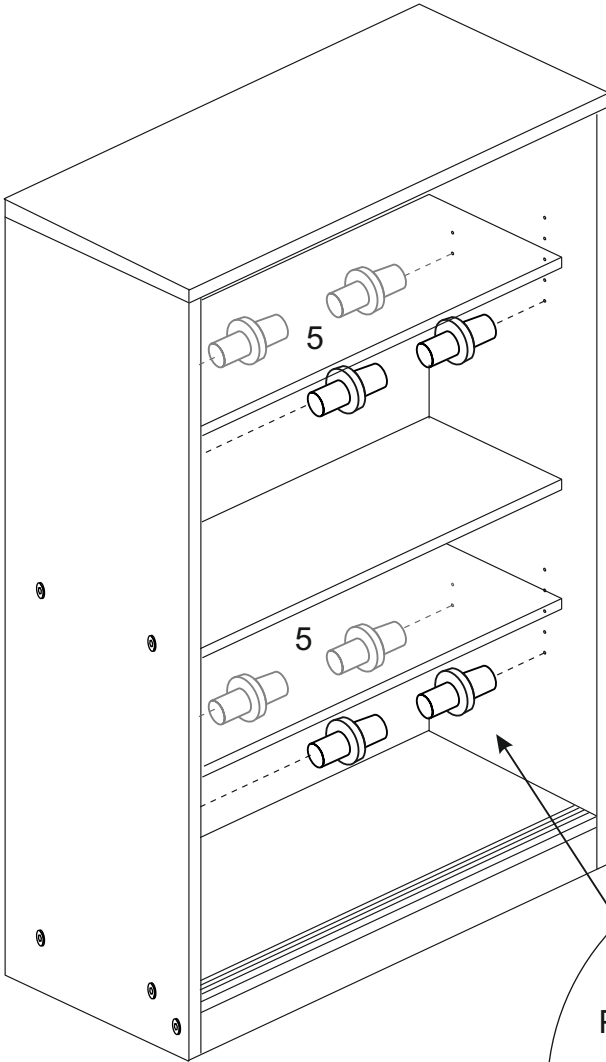
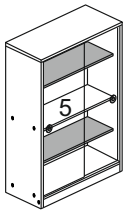
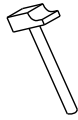
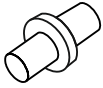

6

Pem x 8

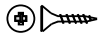

| | | | | |
|---|--|--|--|---|
| 7 | Tirn x 1  | Sali x 2  | Rued x 2  | Rei x 4  |
|---|--|--|--|---|

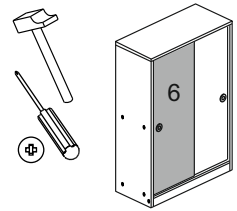

PUERTA IZQUIERDA / LEFT DOOR

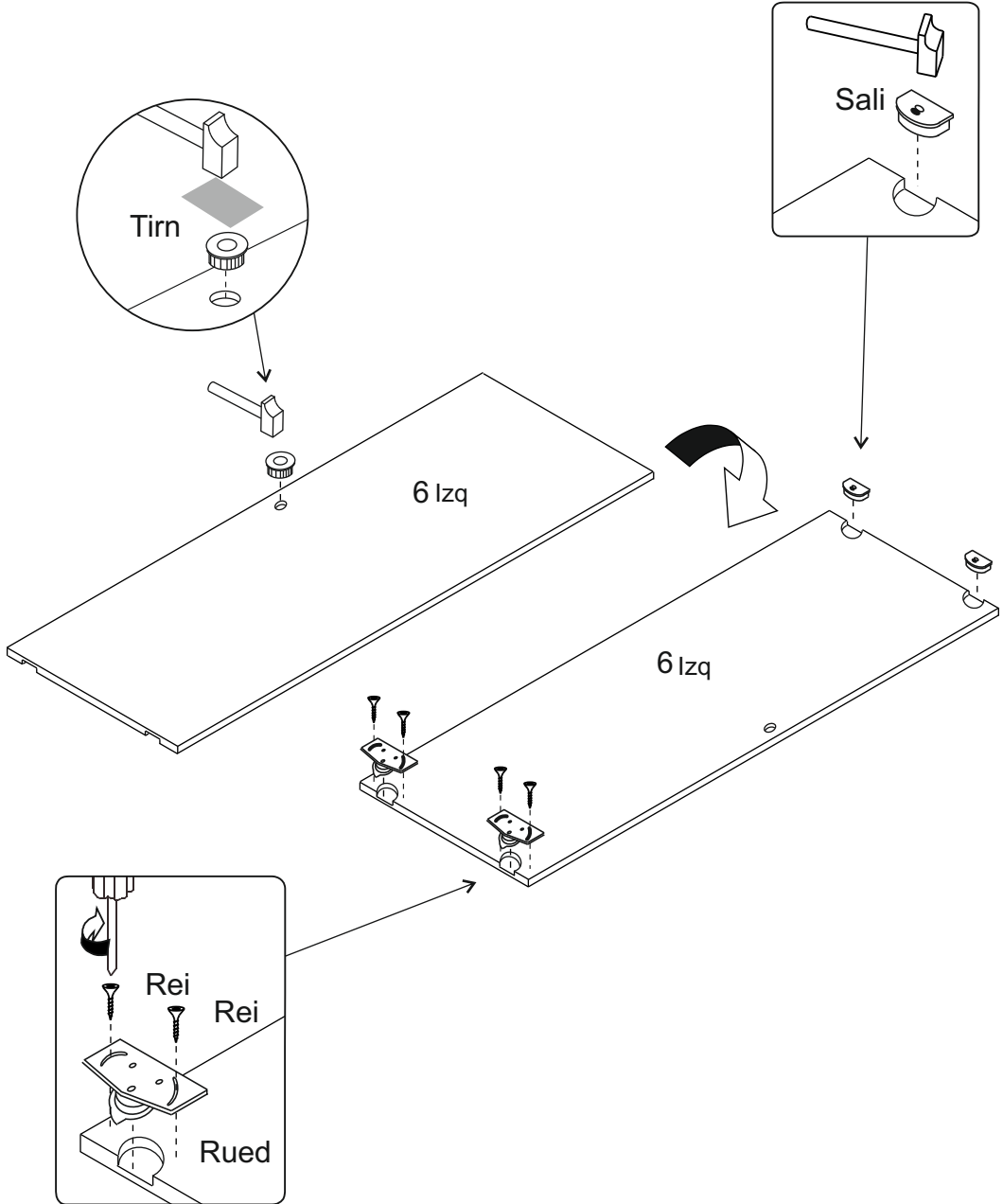

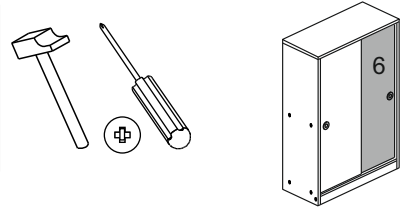
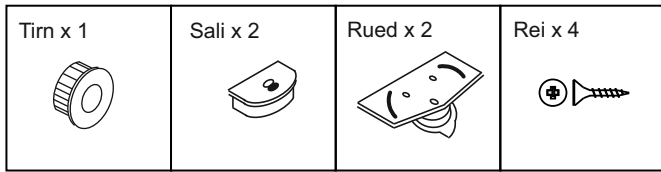

PUERTA DERECHA / RIGHT DOOR

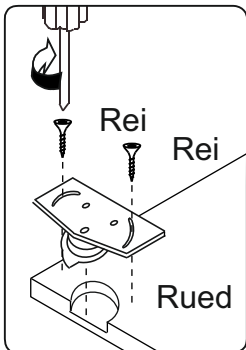
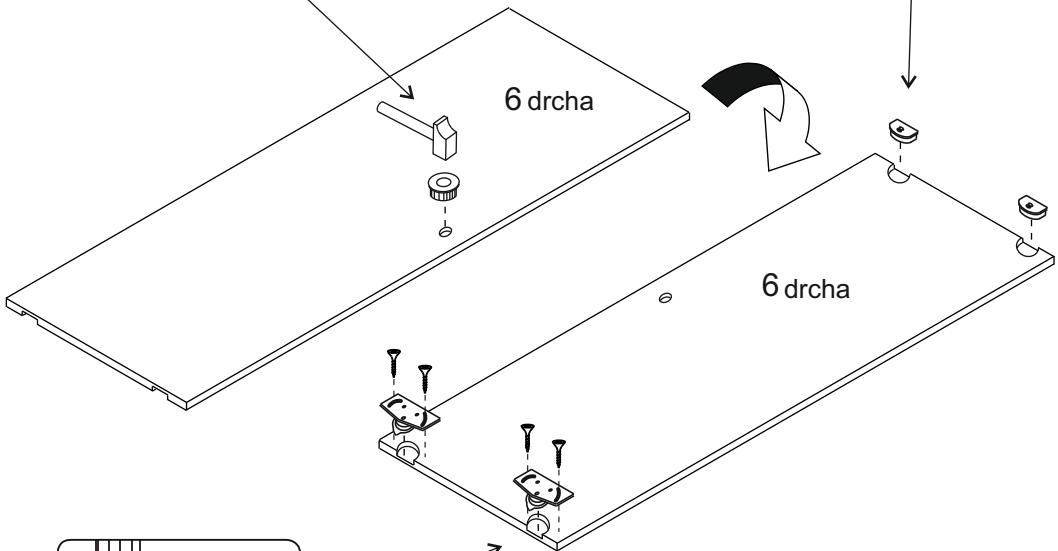
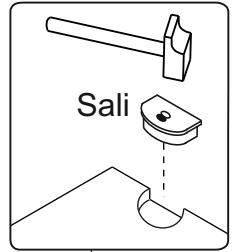
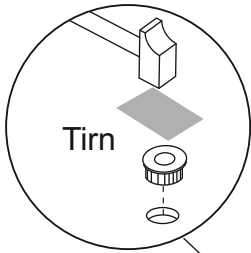

8

A

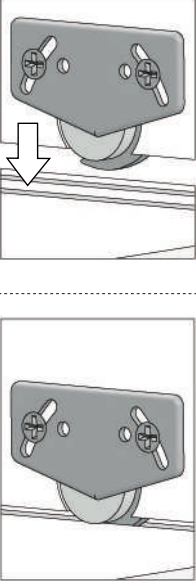

Rueda sobre el carril.
Uña dentro del surco
*Wheel on rail.
Nail inside de groove*

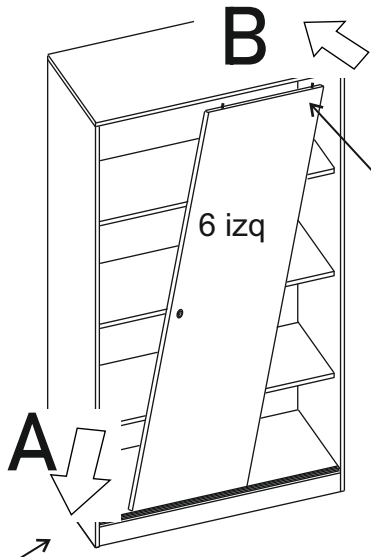

B

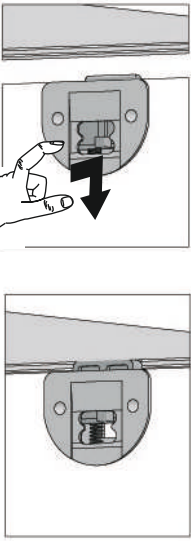

Tirar hacia abajo el muelle para poner dentro del carril
Pull down the spring to put the tab inside de rail

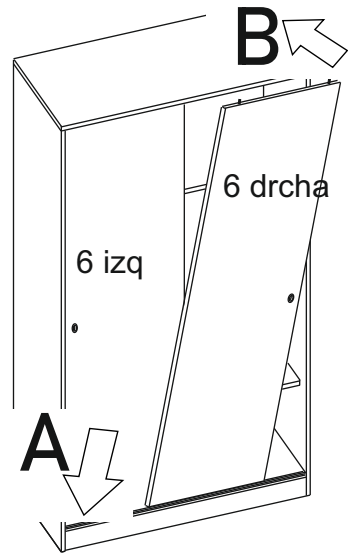

Regulación de puertas Door adjustment

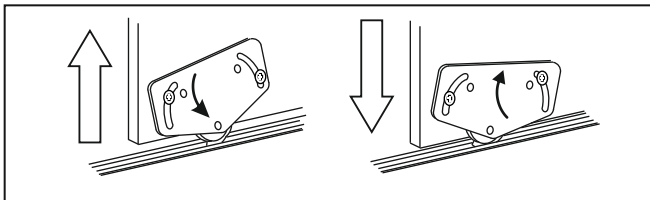

CONDICIONES DE USO Y MANTENIMIENTO

Producto de uso doméstico.

Evitar colocar el mueble cerca de fuentes de calor, de humedad o de una fuerte luz solar.

No lo limpie con productos abrasivos, ni disolventes.

Quitar el polvo antes de limpiarlo.

Utilizar un paño húmedo, limpio y sin pelos.

CONDITIONS OF USE AND MAINTENANCE OF FURNITURE

Product for domestic use only.

Avoid placing the furniture near sources of heat, damp, or strong sunlight.

Do not clean with abrasive products or cleaning products with solvents.

Use a dust remover before any cleaning process.

It is recommended to use a damp, lint-free clean cloth.

**ATENCIÓN AL CLIENTE
CUSTOMER SUPPORT**

(+34)964 321 111

8am-1pm 3pm-5:30pm lunes a viernes
Monday to Friday

Web: www.mueblespitarch.com
e-mail: comercial@mueblespitarch.com

**LOTE/BATCH NUMBER
5042/5044**