

14428



 **Aufbauanleitung**

 **notice de montage**

 **Building Instructions**

 **montagehandleiding**

 **Instrucciones de construcción**

 **Istruzioni per il montaggio**

 **Service-Hotline: +49 421 38693 33**



Vergleichen Sie zuerst die Materialliste mit Ihrem Paketinhalt! Bitte haben Sie Verständnis, dass Beanstandungen nur im nicht aufgebauten Zustand bearbeitet werden können!



Commencez par comparer la liste du matériel avec le contenu de votre paquet! Sachez que nous traitons uniquement les réclamations concernant le matériel à l'état non monté!



First compare the list of materials with your package contents! Please understand that complaints can be processed in the non-built status only!



Vergelijk eerst de lijst van materialen met de inhoud van uw pakket! Reclamaties kunnen alleen in behandeling worden genomen zolang de onderdelen nog niet zijn gemonteerd!



En primer lugar, compare la lista de material con el contenido del paquete. Rogamos entienda que las reclamaciones sólo pueden ser tramitadas antes de montar el objeto!



Confrontate questa distinta materiali prima con il contenuto del pacchetto! Vi preghiamo di comprendere che eventuali reclami possono essere accolti solo prima del montaggio!



14428



1 x W1 | 2040 x 2324 x 40mm | ID 20820

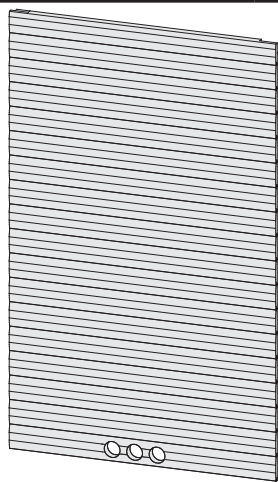

1 x W4 | 1930 x 1000 x 40mm | ID 20724

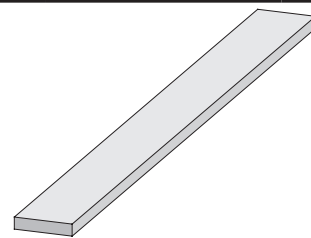

| | | |
|---------|------------------|----------|
| 2 x B1 | 1920 x 20 x 3mm | ID 20799 |
| 2 x B2 | 1800 x 78 x 17mm | ID 48524 |
| 1 x B3 | 2300 x 78 x 17mm | ID 48530 |
| 2 x B4 | 800 x 45 x 18mm | ID 24796 |
| 1 x B5 | 300 x 95 x 18mm | ID 19130 |
| 4 x B6 | 480 x 95 x 18mm | ID 20930 |
| 4 x B7 | 565 x 95 x 18mm | ID 15498 |
| 4 x B8 | 60 x 38 x 28mm | ID 20928 |
| 3 x B9 | 575 x 38 x 28mm | ID 21788 |
| 2 x B10 | 1400 x 38 x 28mm | ID 26113 |
| 2 x B11 | 1731 x 38 x 28mm | ID 20698 |
| 2 x B12 | 2191 x 38 x 28mm | ID 20700 |
| 2 x B13 | 800 x 58 x 28mm | ID 15493 |



2 x W2 | 2040 x 1770 x 40mm | ID 20719



1 x W5 | 1930 x 532 x 40mm | ID 20715

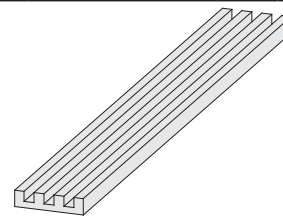

1 x E1 | 1850 x 110 x 26mm | ID 26480

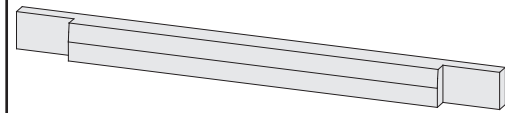

1 x E2 | 935 x 121 x 47mm | ID 58578

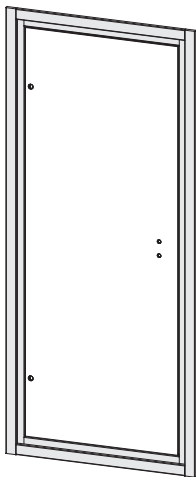

1 x W3 | 1905 x 815 x 40mm | ID 20527

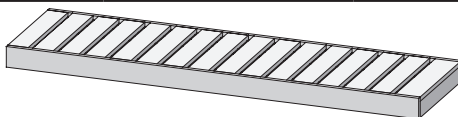

1 x L1 | 1177 x 500 x 90mm | ID 52065
2 x L2 | 2243 x 550 x 90mm | ID 52063



1 x E3 | 2324 x 121 x 38mm | ID 40736

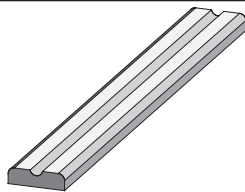

1 x L3 | 1177 x 90 x 22mm | ID 26156
1 x L4 | 1745 x 90 x 22mm | ID 26155
1 x L5 | 2243 x 90 x 22mm | ID 26119

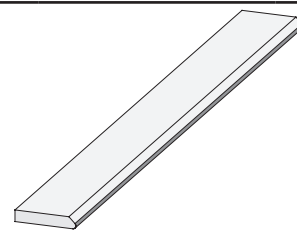

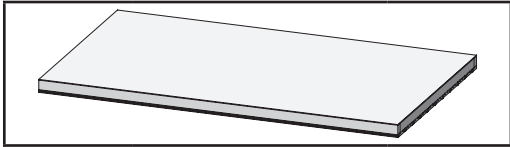

6 x G1 | 2085 x 78 x 18mm | ID 48525

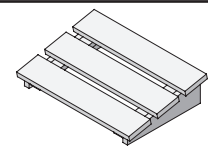

| | | |
|--------|-------------------|----------|
| 1 x M1 | 1727 x 435 x 57mm | ID 43912 |
| 2 x M1 | 1727 x 904 x 57mm | ID 43858 |

| | | |
|-----|---|----------|
| 1 x |  | ID 20708 |
|-----|---|----------|

| | | |
|---|----------|----------|
|  | | |
| 60 x | 4 x 35mm | ID 3687 |
| 100 x | 4 x 50mm | ID 3688 |
| 25 x | 4 x 70mm | ID 3689 |
| 35 x | 6 x 60mm | ID 14014 |

| | | |
|---|------------|----------|
|  | | |
| 50 x | 4,5 x 40mm | ID 26285 |

| | | |
|--------|--|----------|
| 6 x S1 |  | ID 14266 |
|--------|--|----------|

| | | |
|---|------------|----------|
|  | | |
| 50 x S2 | 4,5 x 30mm | ID 26116 |
| 6 x S3 | 12 x 18mm | ID 46403 |

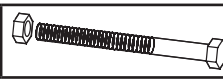
| | | |
|--------|---|----------|
| 3 x S4 |  | ID 14018 |
|--------|---|----------|

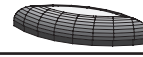
| | | |
|--------|---|----------|
| 6 x T1 |  | ID 26118 |
|--------|---|----------|

| | | |
|-----|---|----------|
| 1 x |  | ID 26114 |
|-----|---|----------|

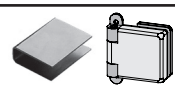
| | | |
|-----|---|----------|
| 2 x |  | ID 26496 |
|-----|---|----------|

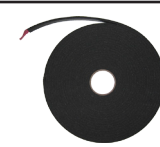
| | | |
|-----|--|----------|
| 10m |  | ID 14025 |
|-----|--|----------|

| | | |
|-----|---|----------|
| 1 x |  | ID 64231 |
|-----|---|----------|

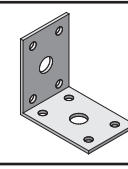
| | | |
|-----|---|----------|
| 2 x |  | ID 20803 |
|-----|---|----------|

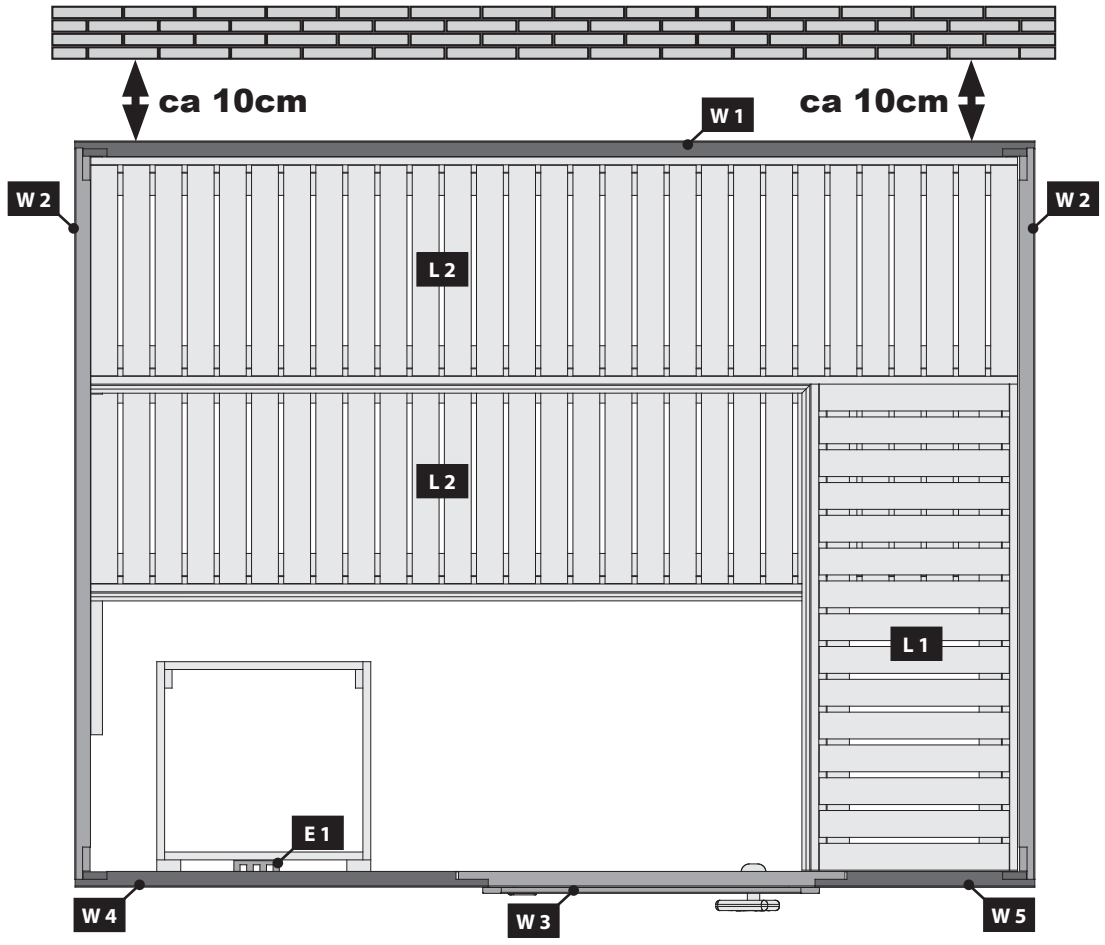

02

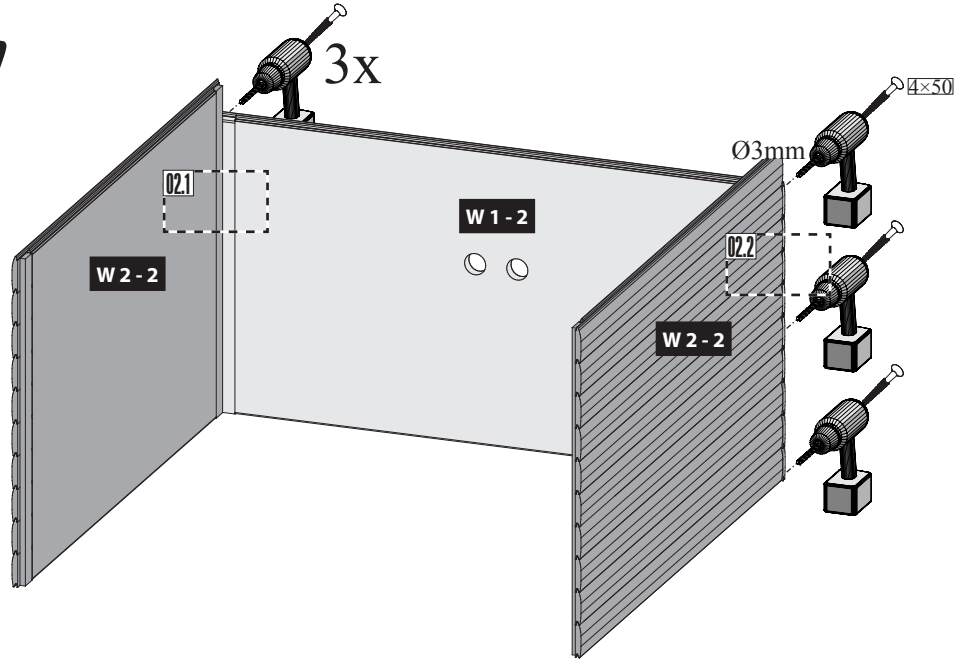
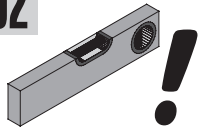

02.1

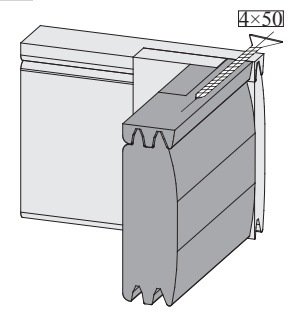

02.2

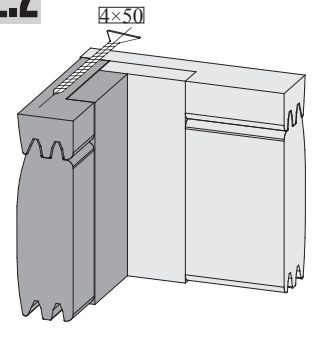

03

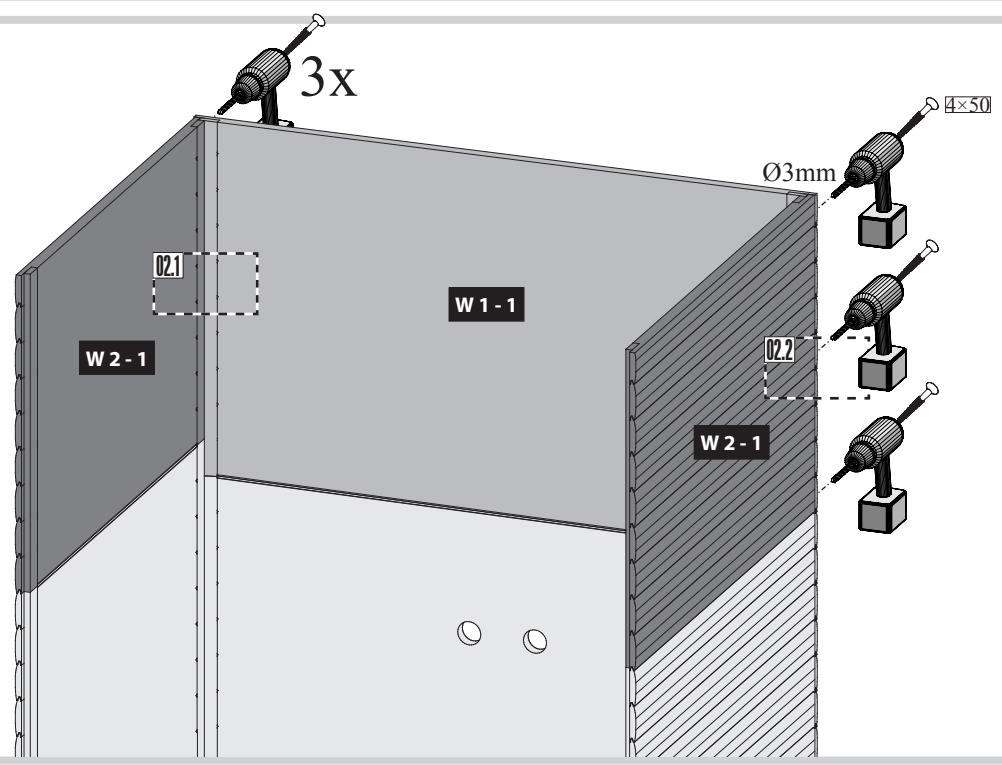

04

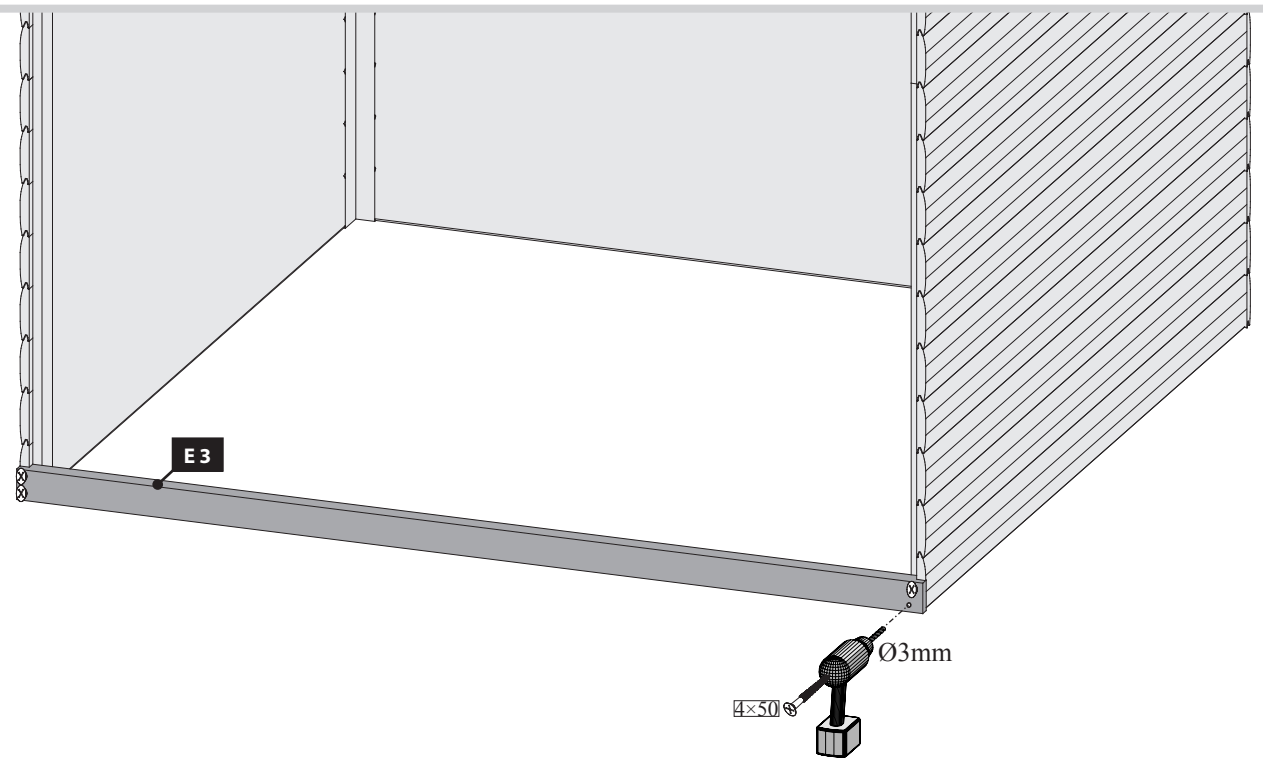

05

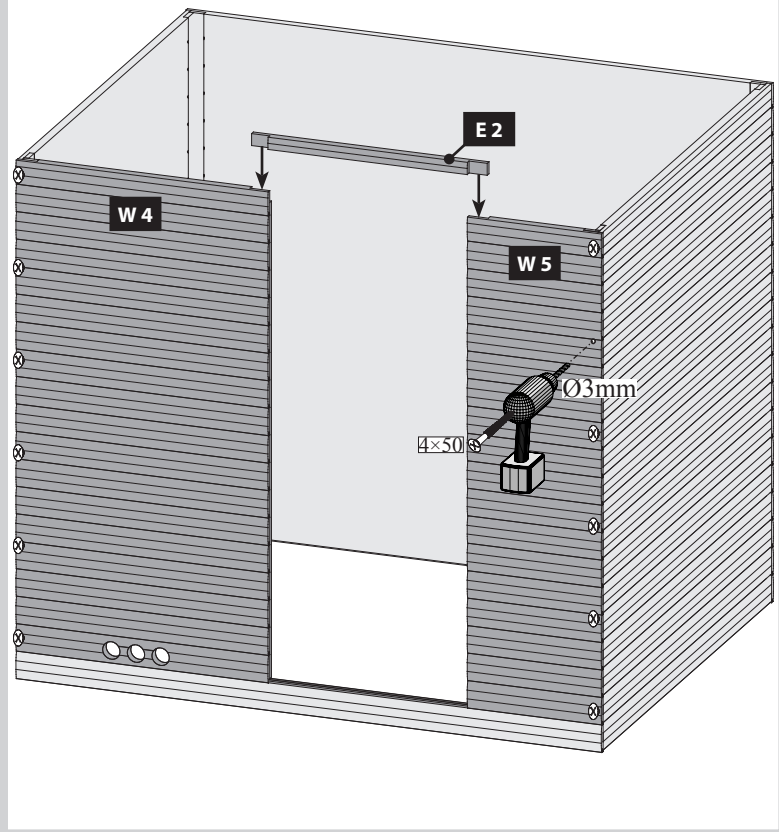

06

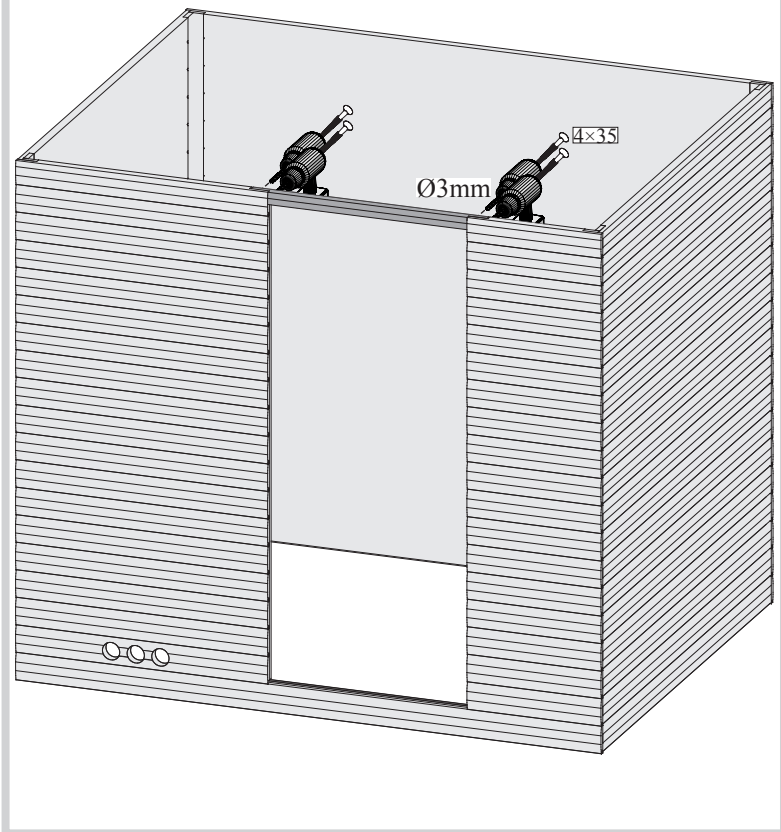

07

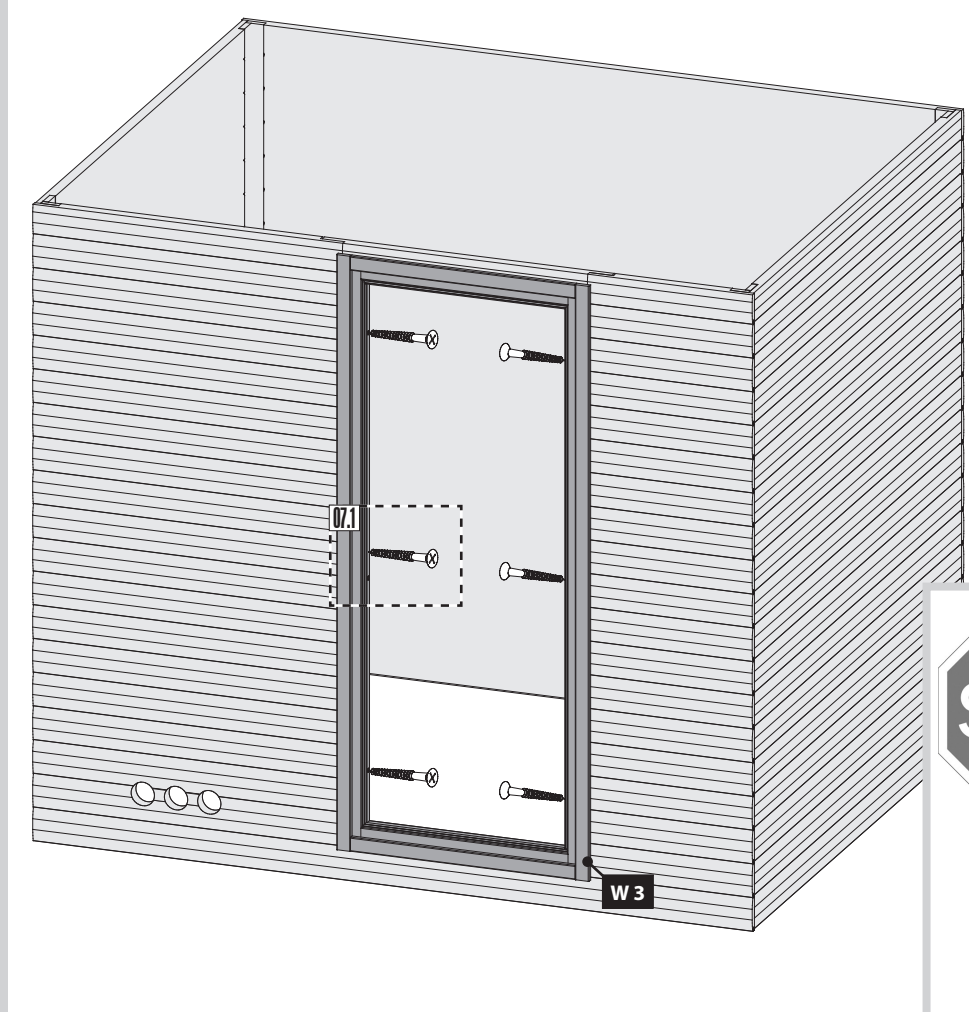



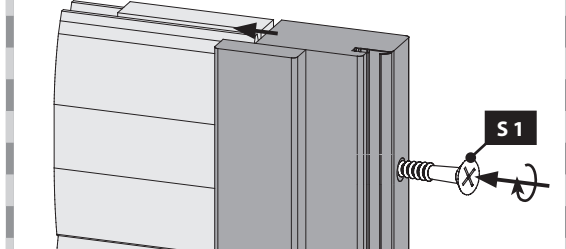

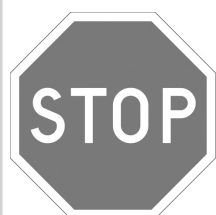
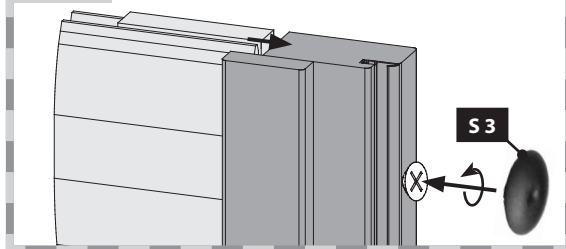

07.1-1



07.1-2



-  Einbau Glastür
-  Montage porte en verre
-  Installation of glass door
-  Montage van de glazen deur
-  Montaje de la puerta de cristal
-  Installazione portello di vetro

!!!

01 — 03

!!!

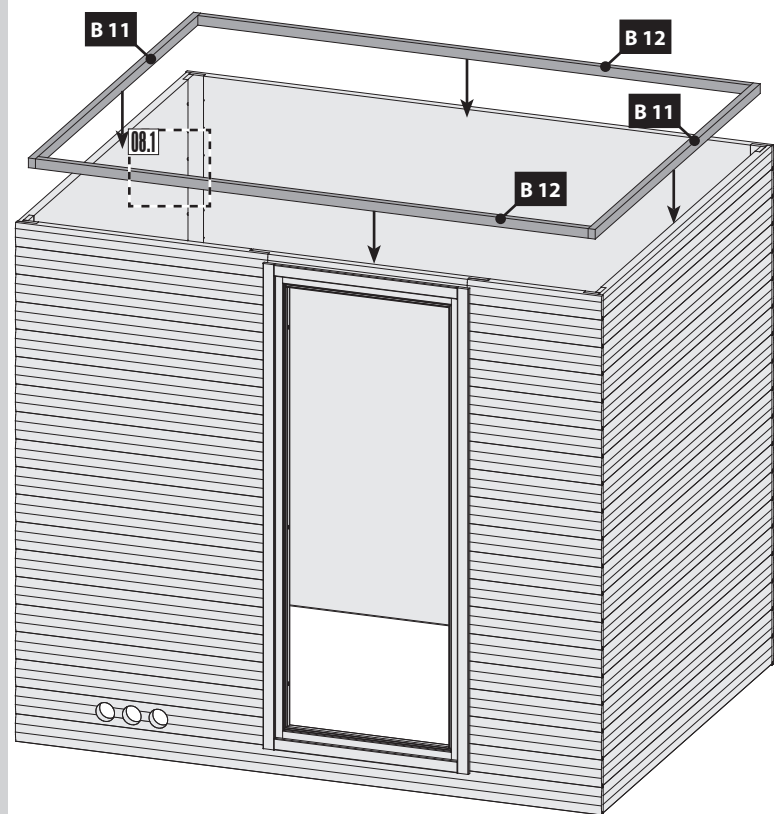
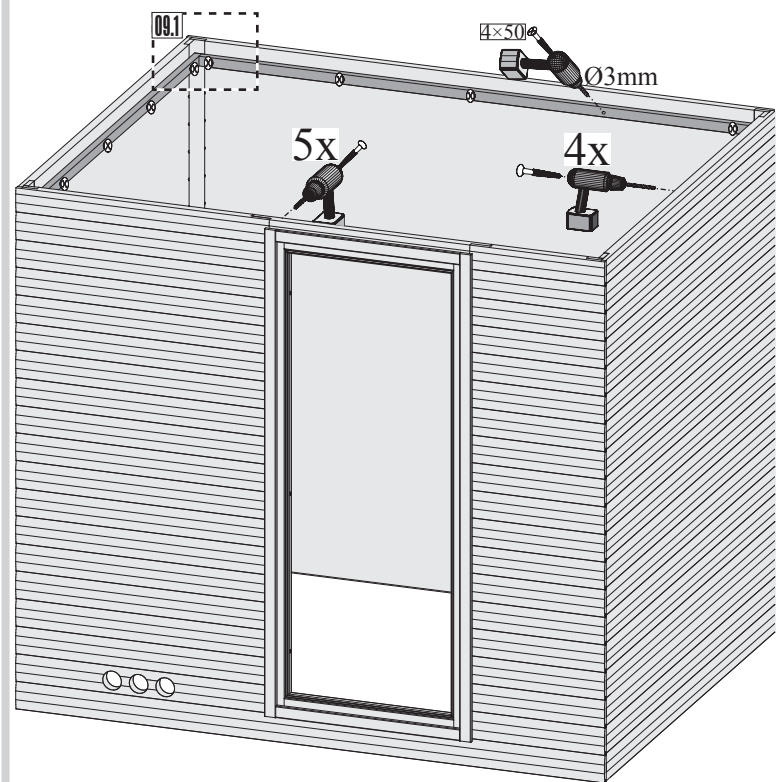
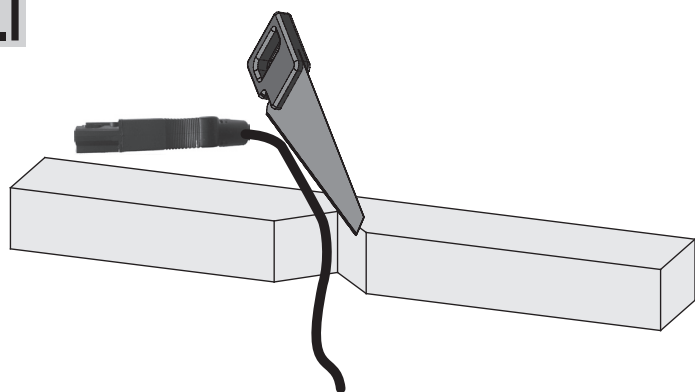
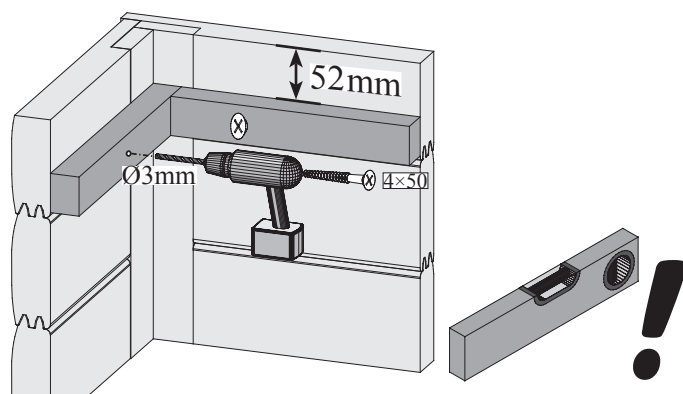
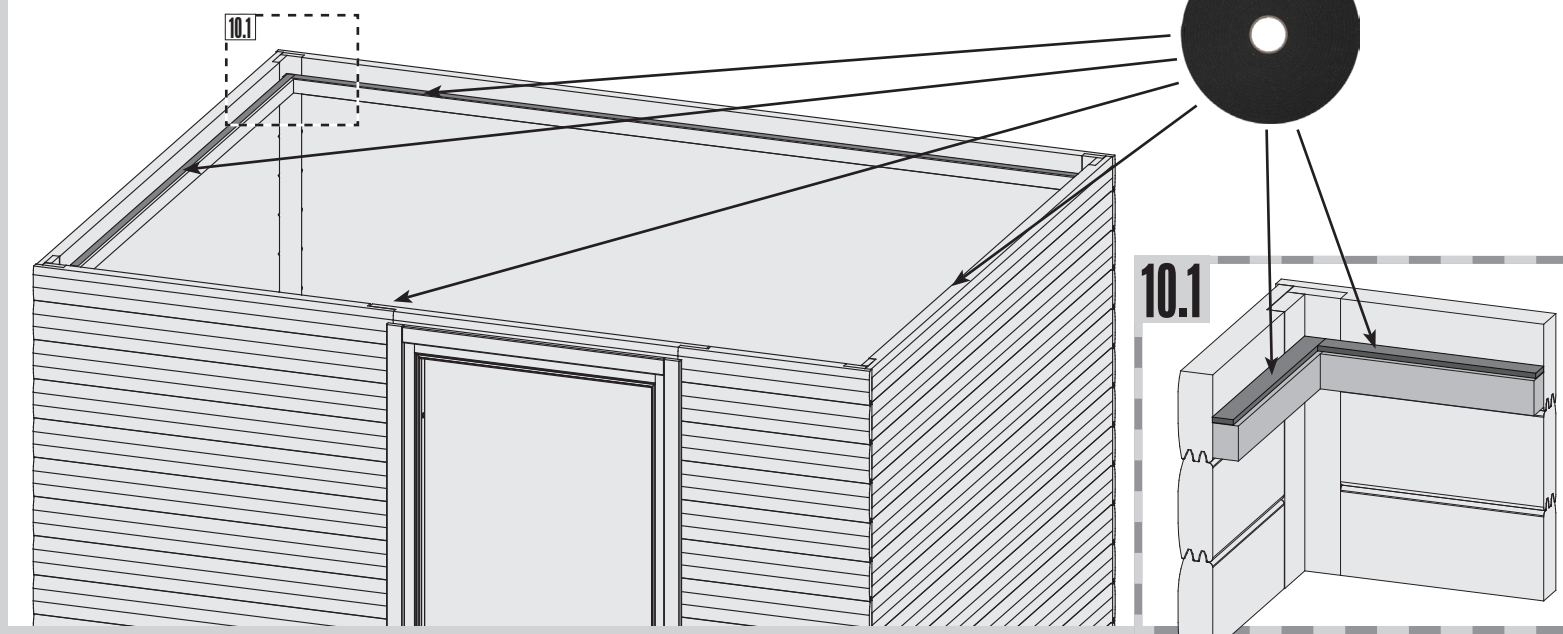
08**09****08.1****09.1****10**

11

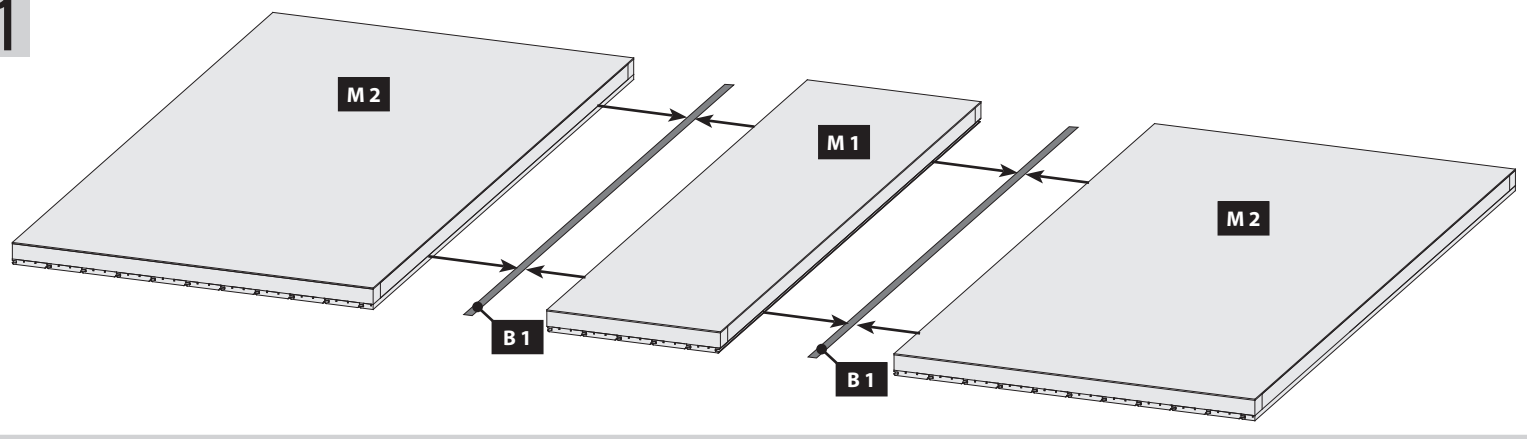

12

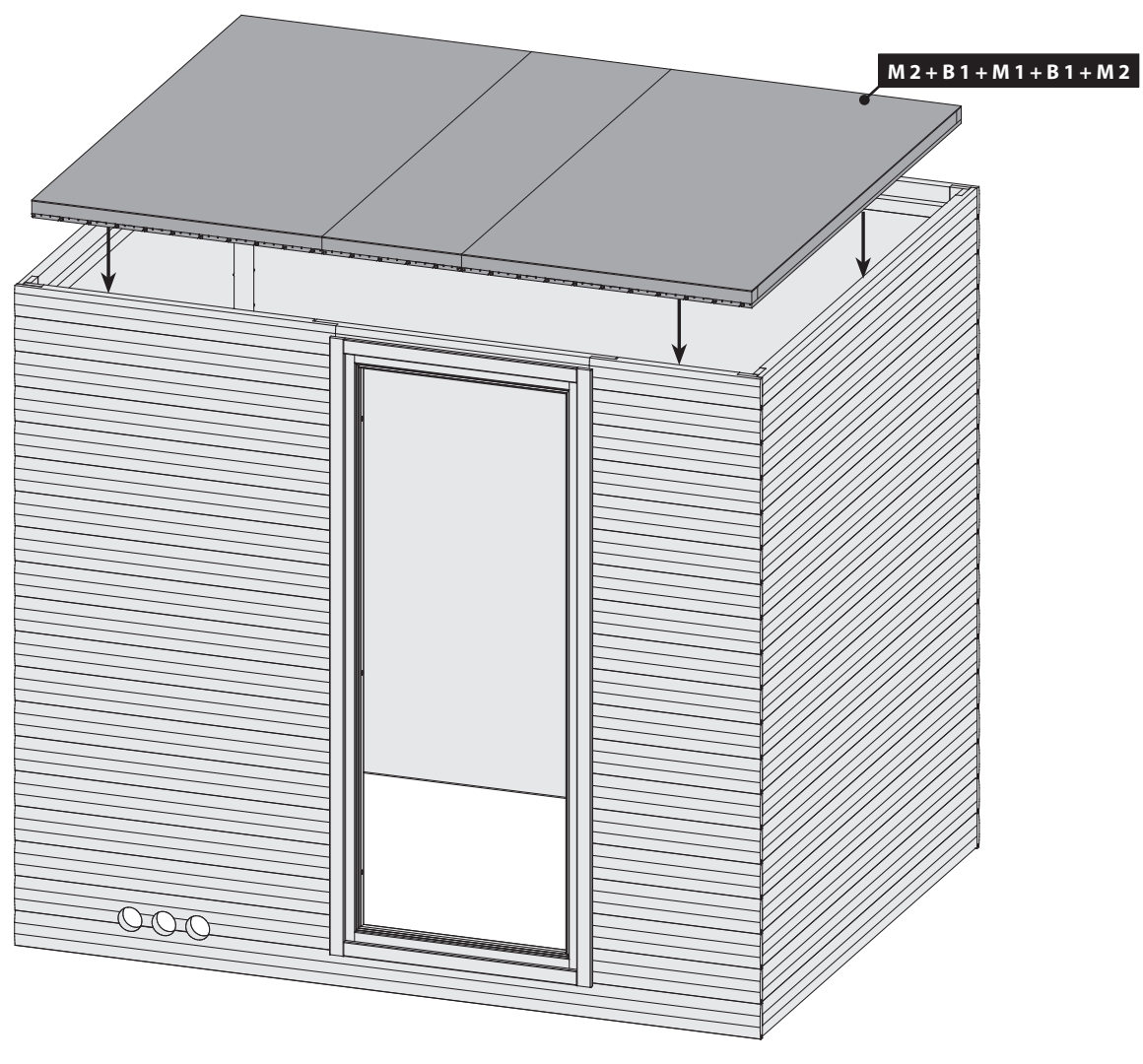

13

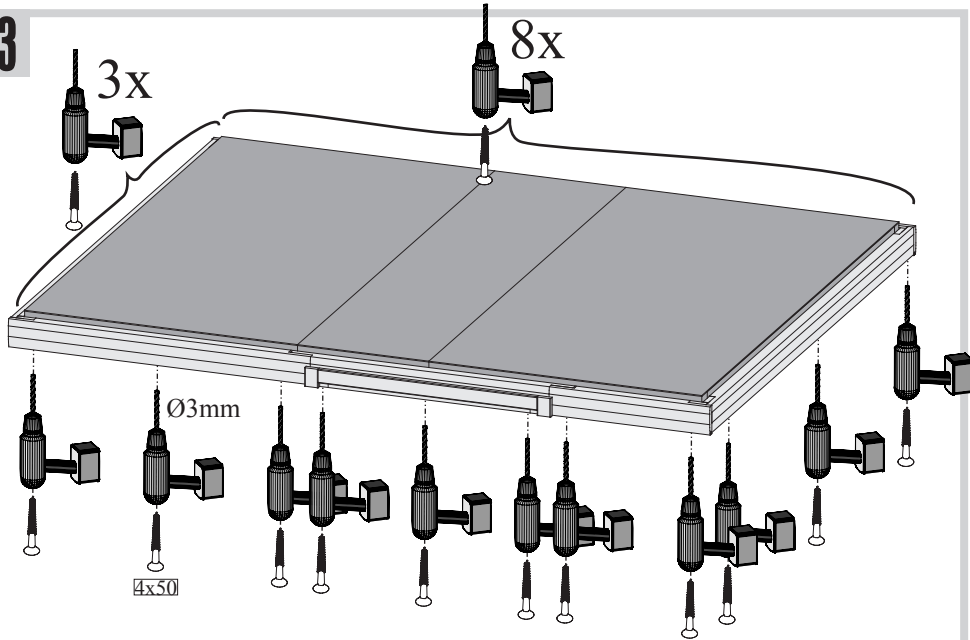

13.1

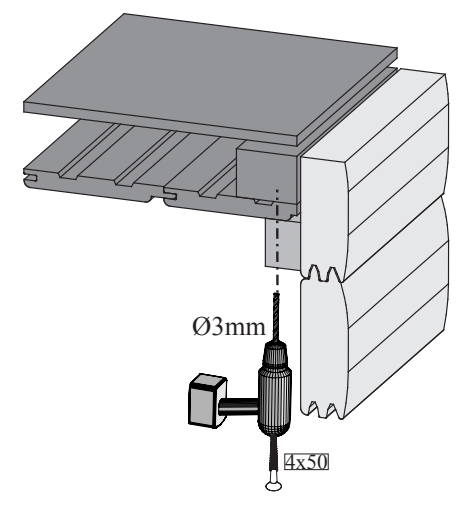

14

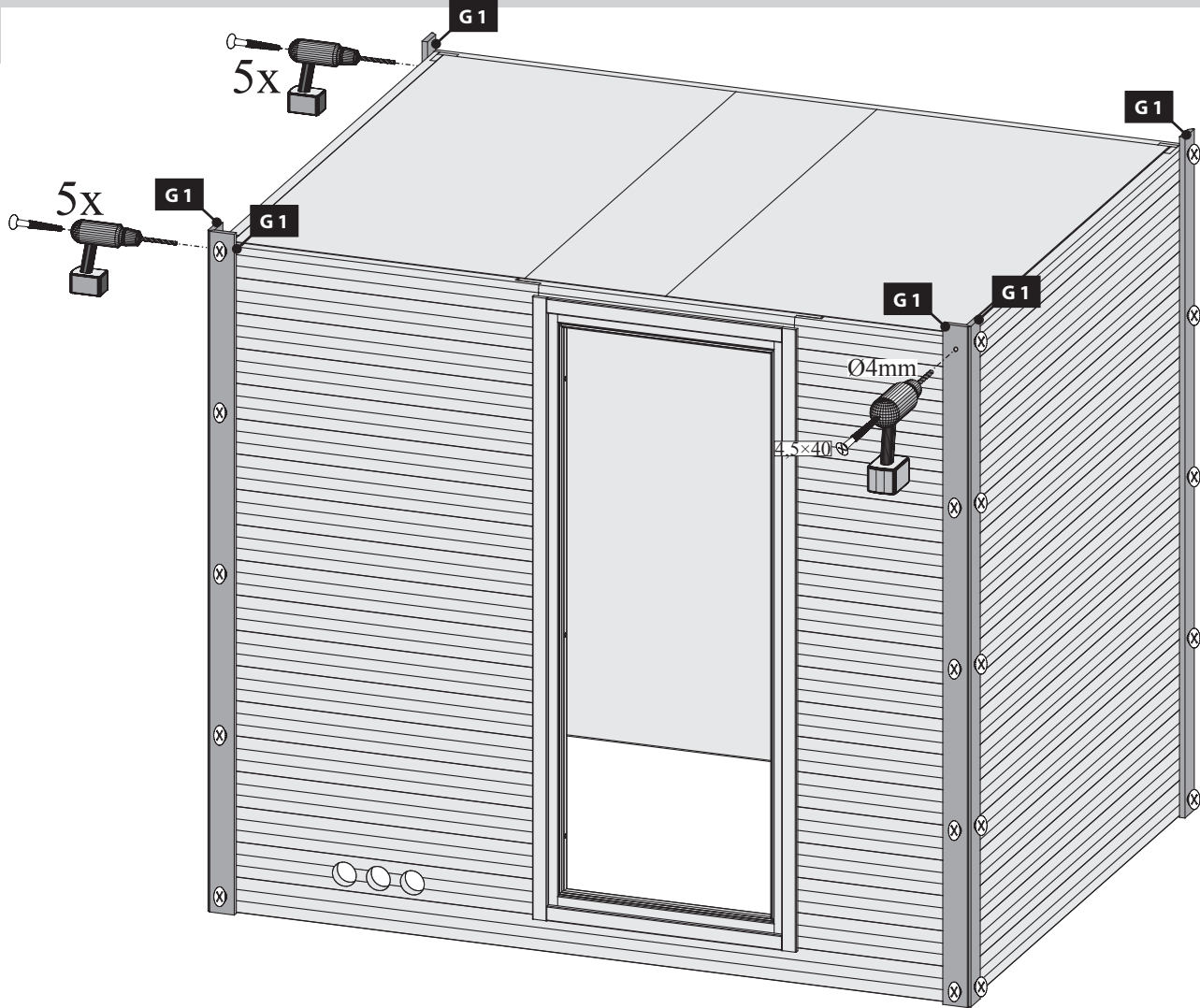

15

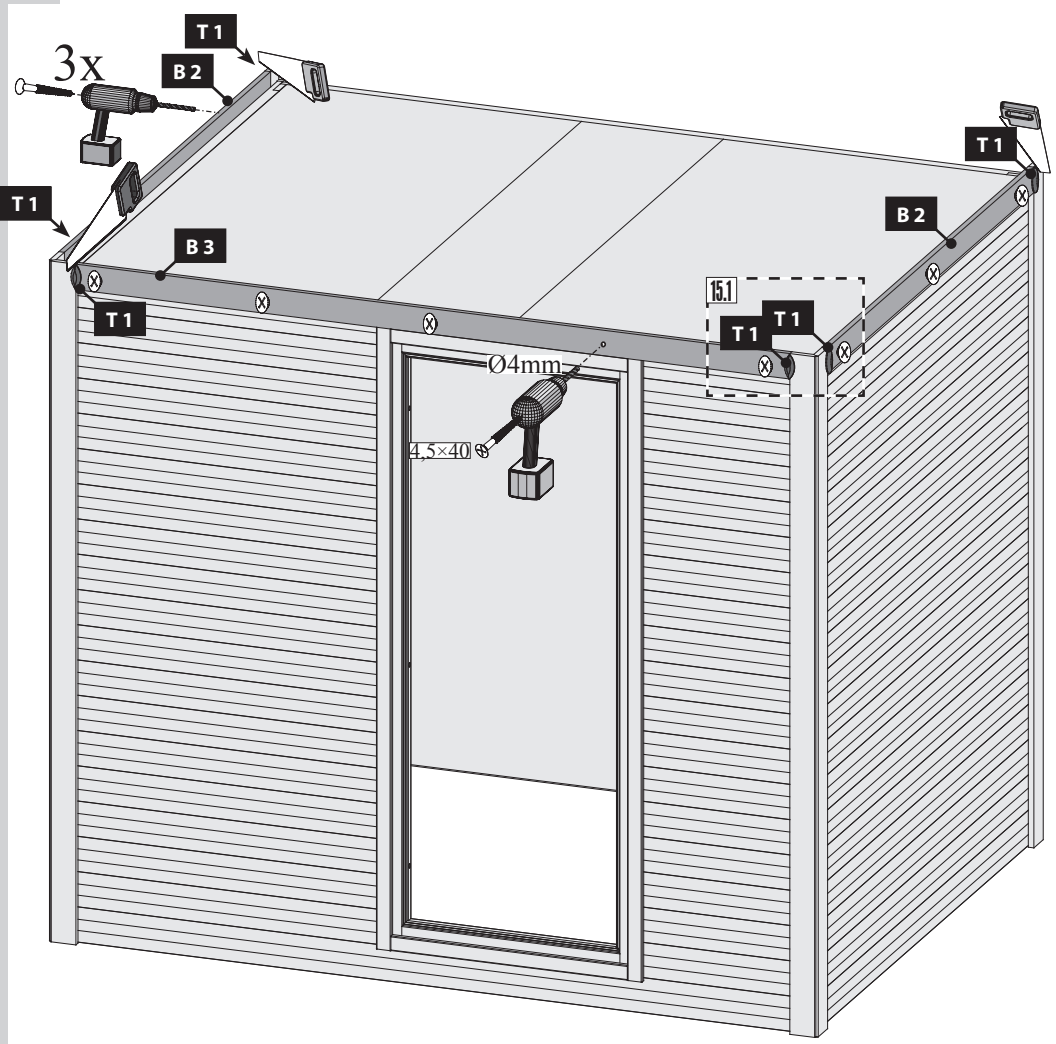

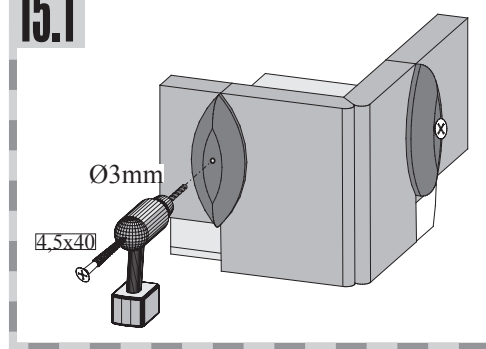

15.1



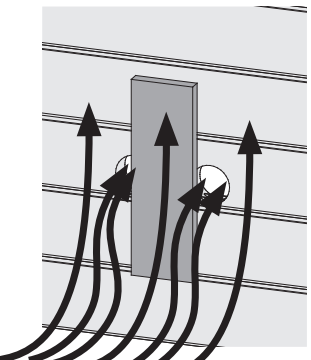
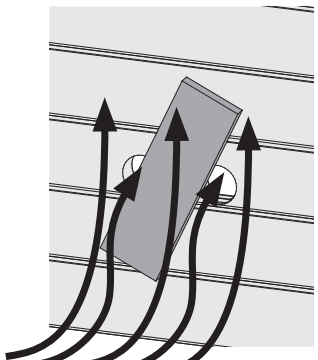
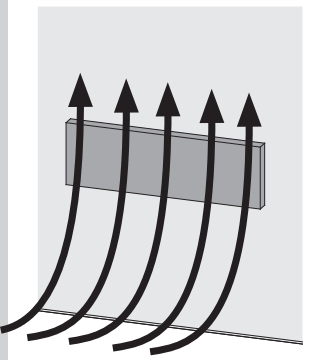
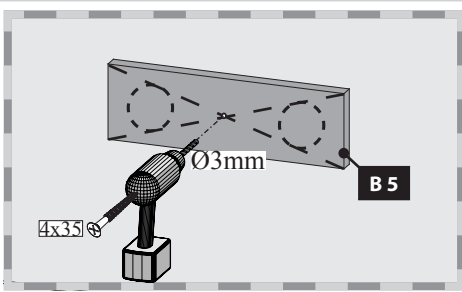
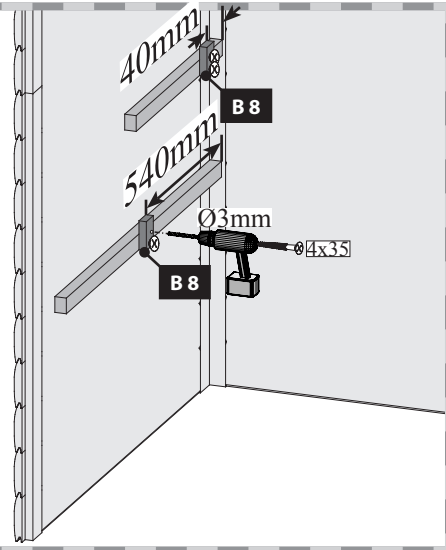
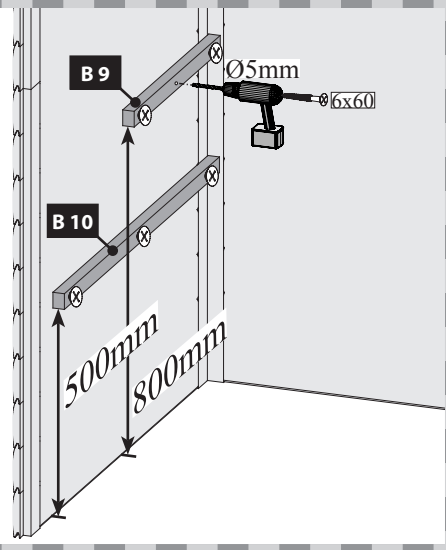
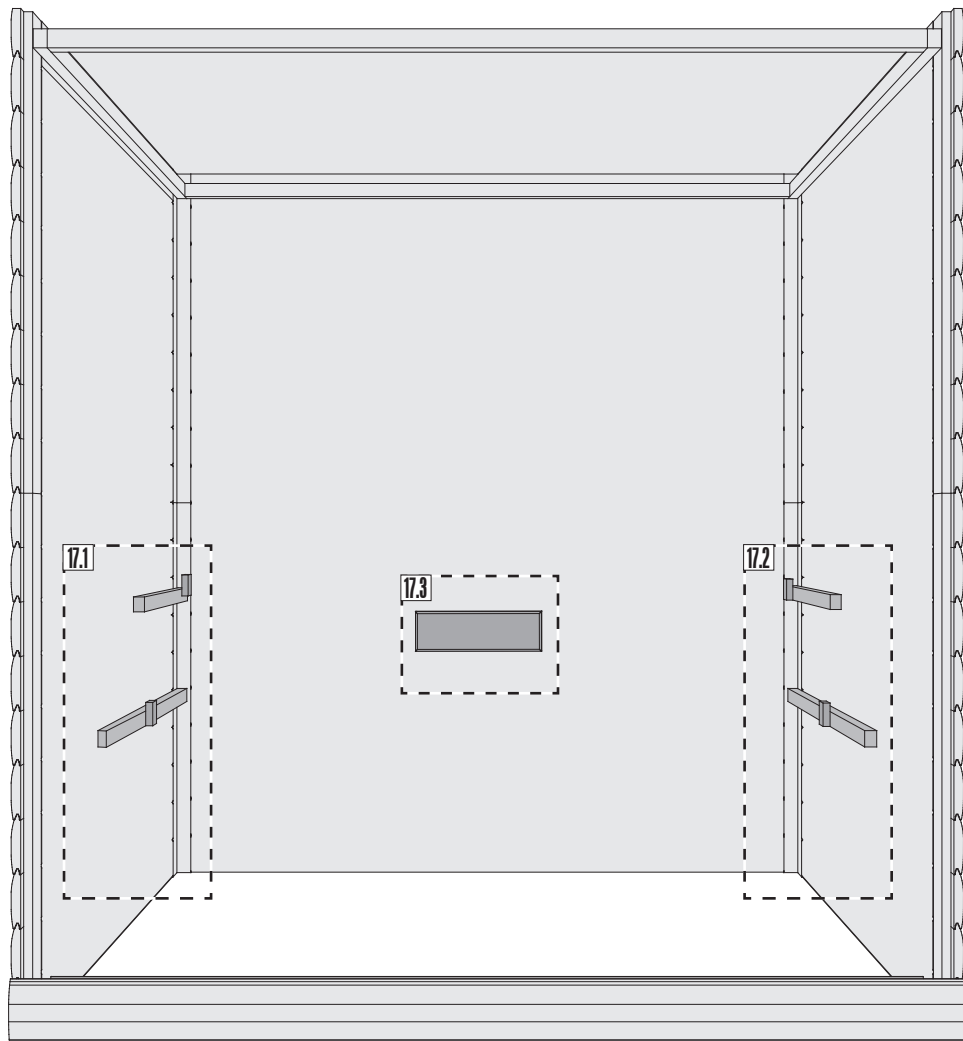

16







 Hier ist die Funktionsweise des Brettes abgebildet. Regeln Sie damit die Abluft nach Ihren eigenen Wünschen.

 Ceci représente le mode de fonctionnement de la planche. Avec elle, réglez l'écoulement de l'air selon vos désirs.

 This figure shows the functional principle of the board. Regulate the exhaust air according to your own wishes.

 Hier is de werking van het plankje afgebeeld. Regel daarmee de luchtafvoer naar eigen wens.

 Aquí está representada la forma de funcionamiento de la tabla. Regule con ello el aire de salida según sus propios deseos.

 Viene illustrato il principio di funzionamento della tavoletta di regolazione della ventilazione. Con essa si può regolare a piacere la ventilazione.

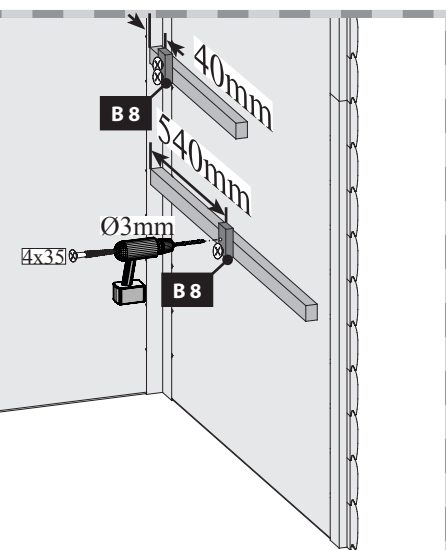
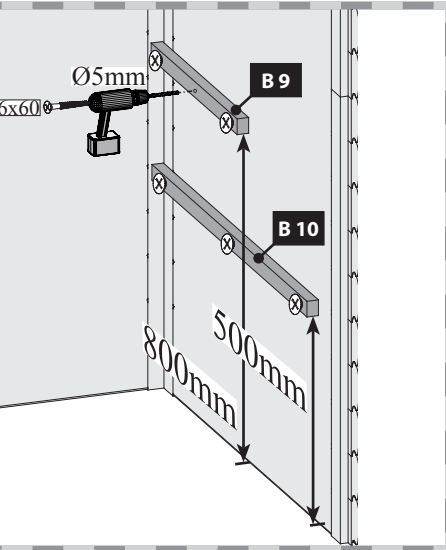

18

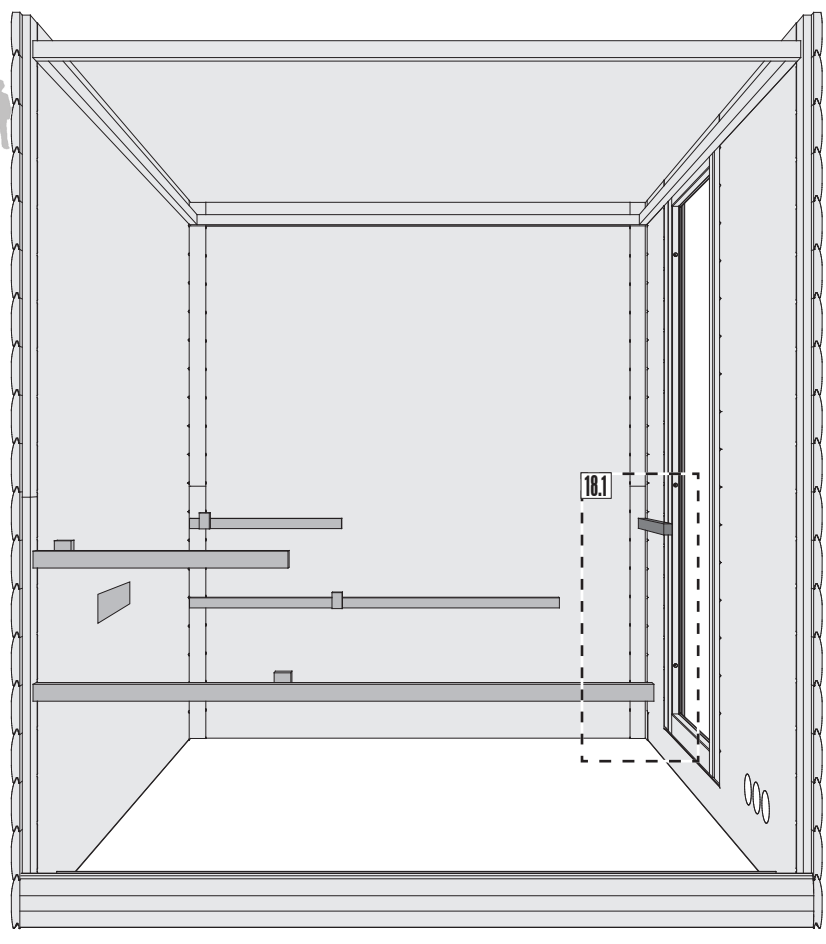
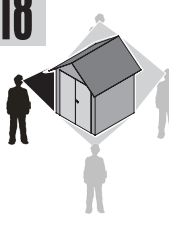

18.1-1

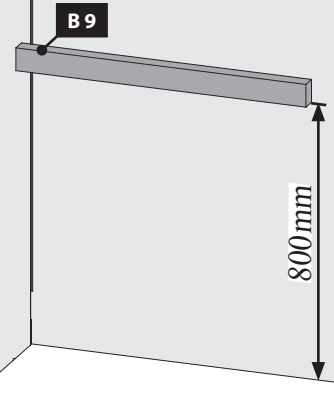

18.1-1

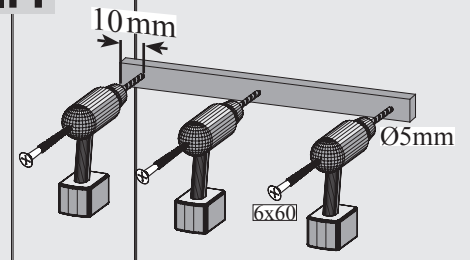

19

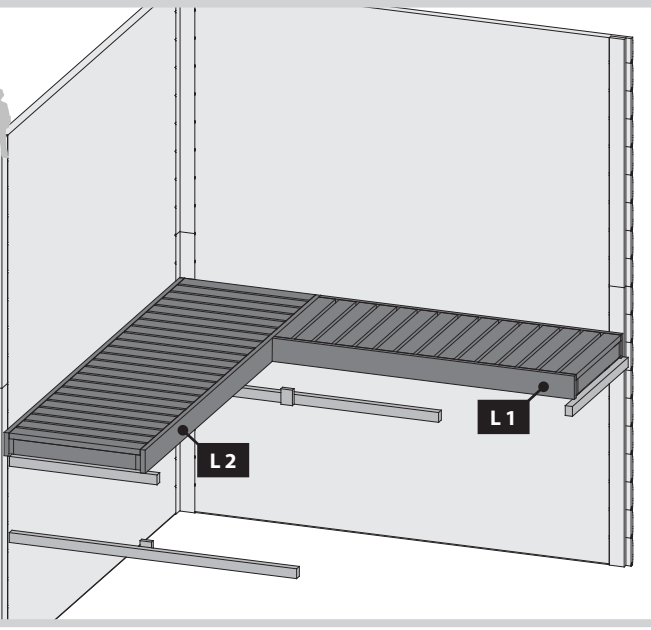
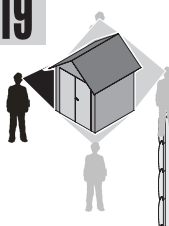

21

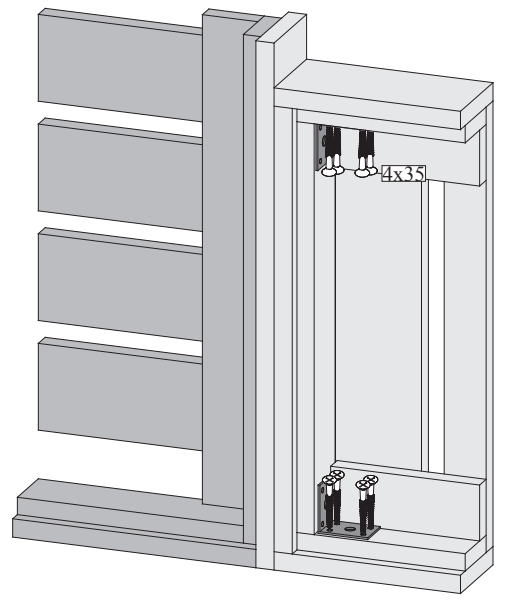

20

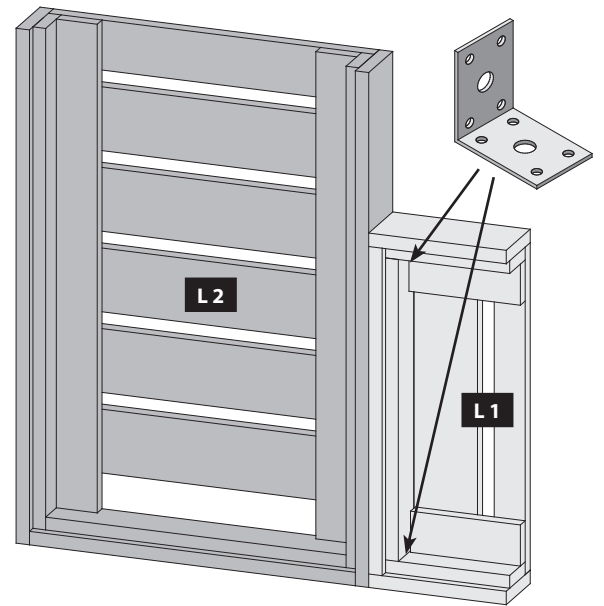
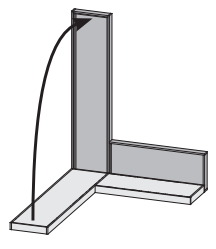

22

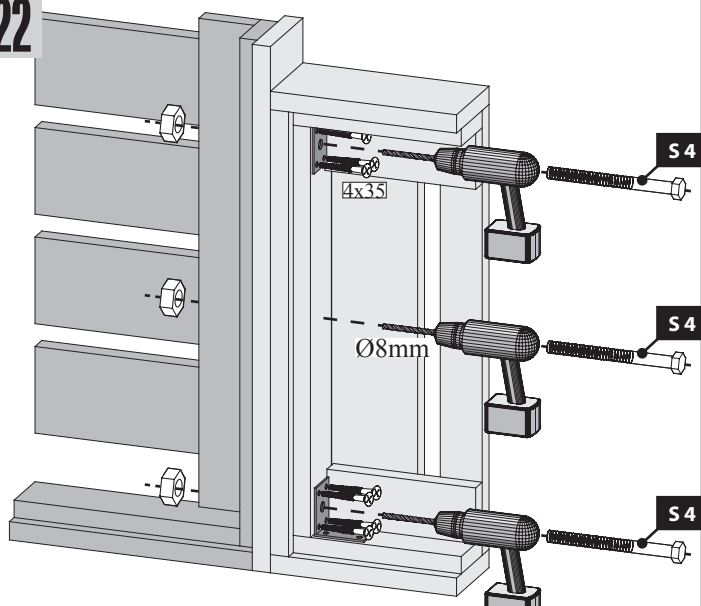

23

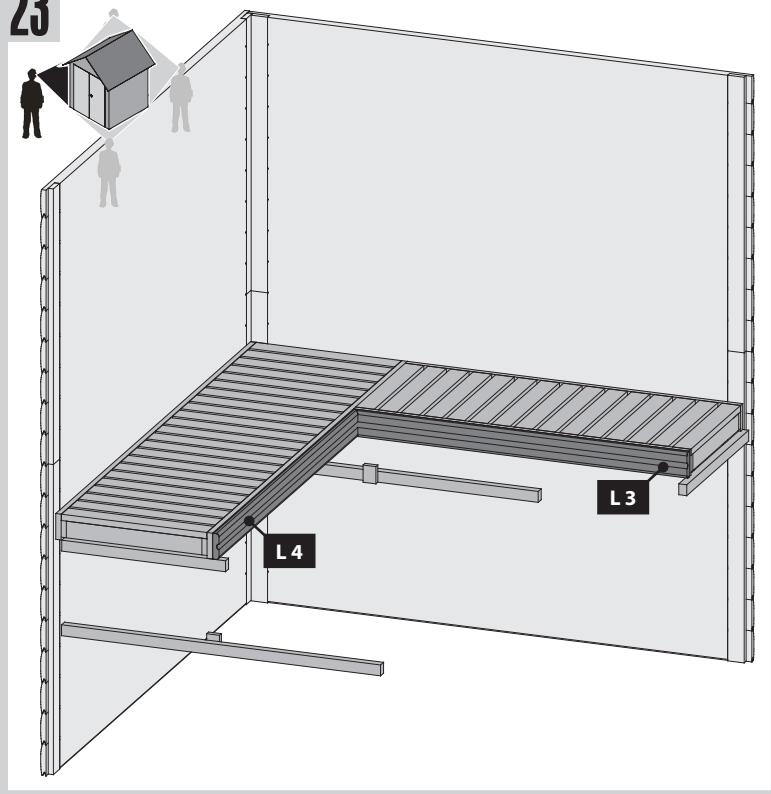

24

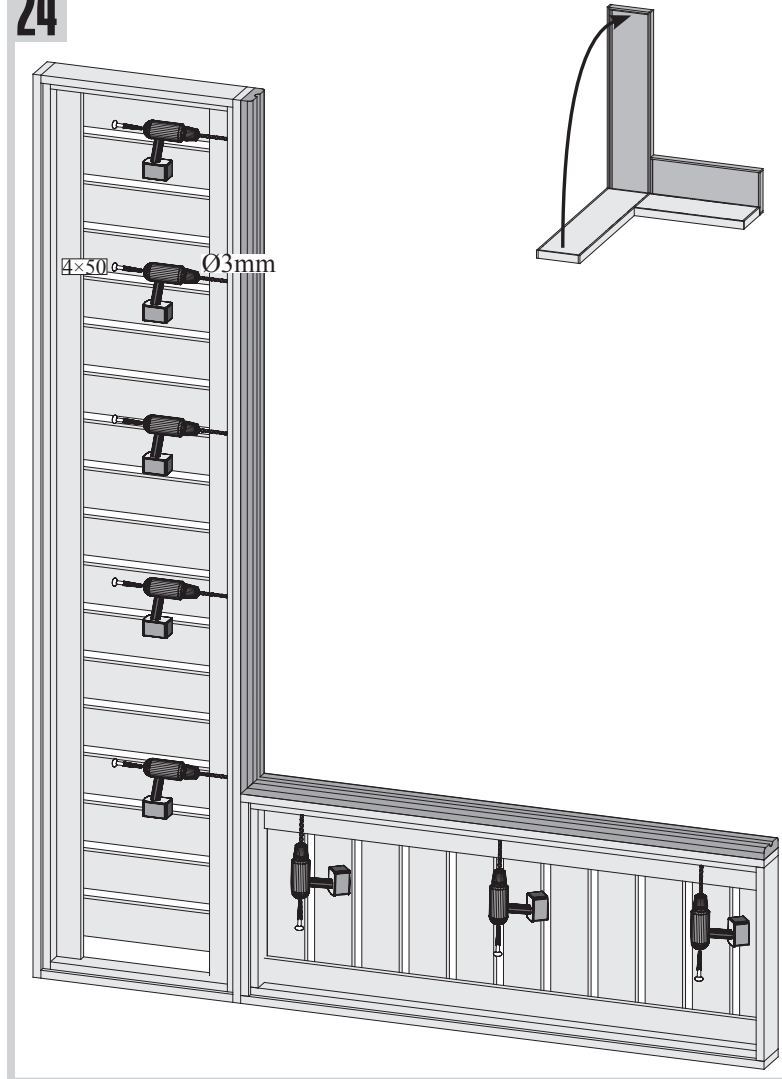

25

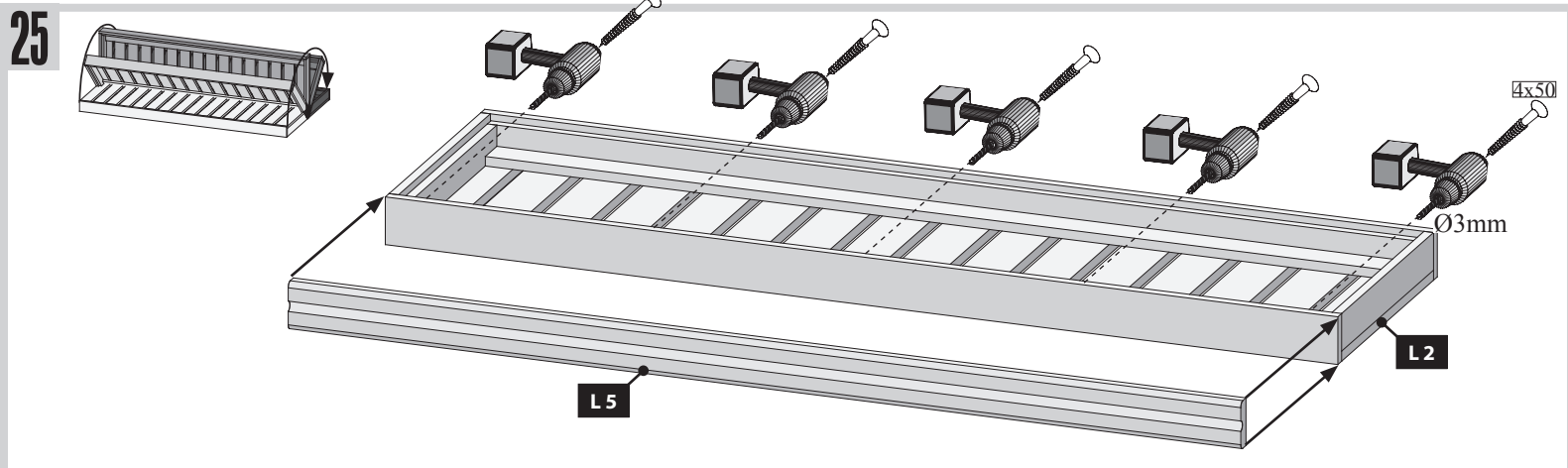

26

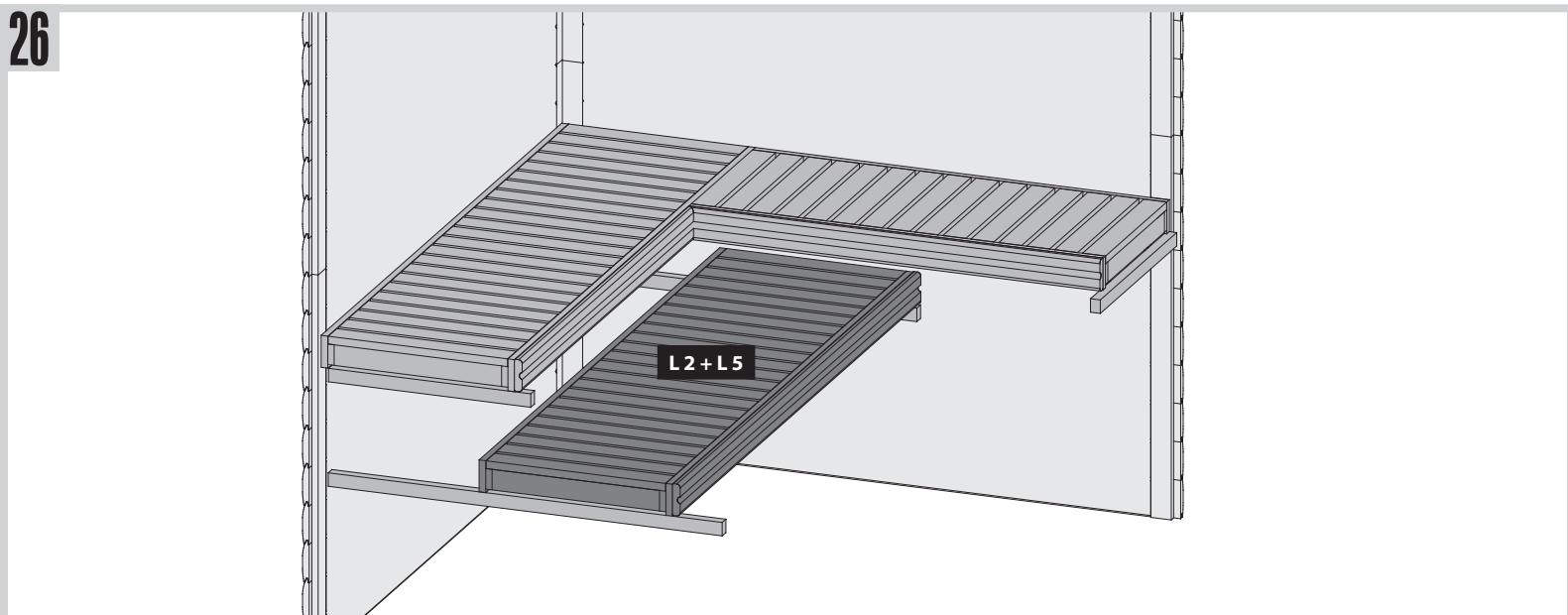

27 2x

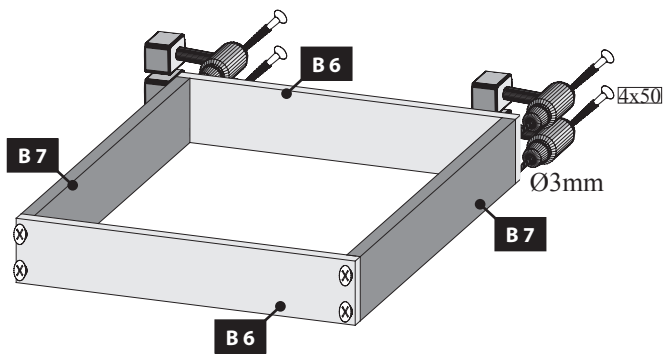

28

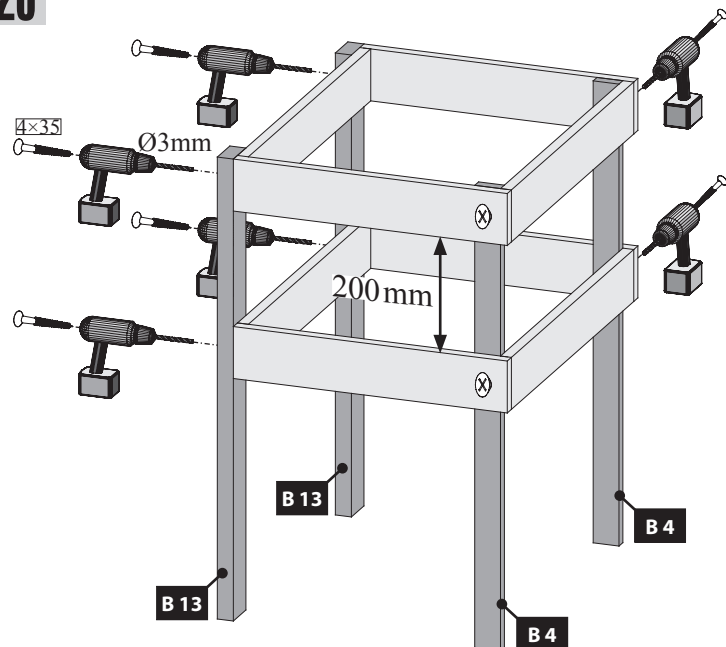

29

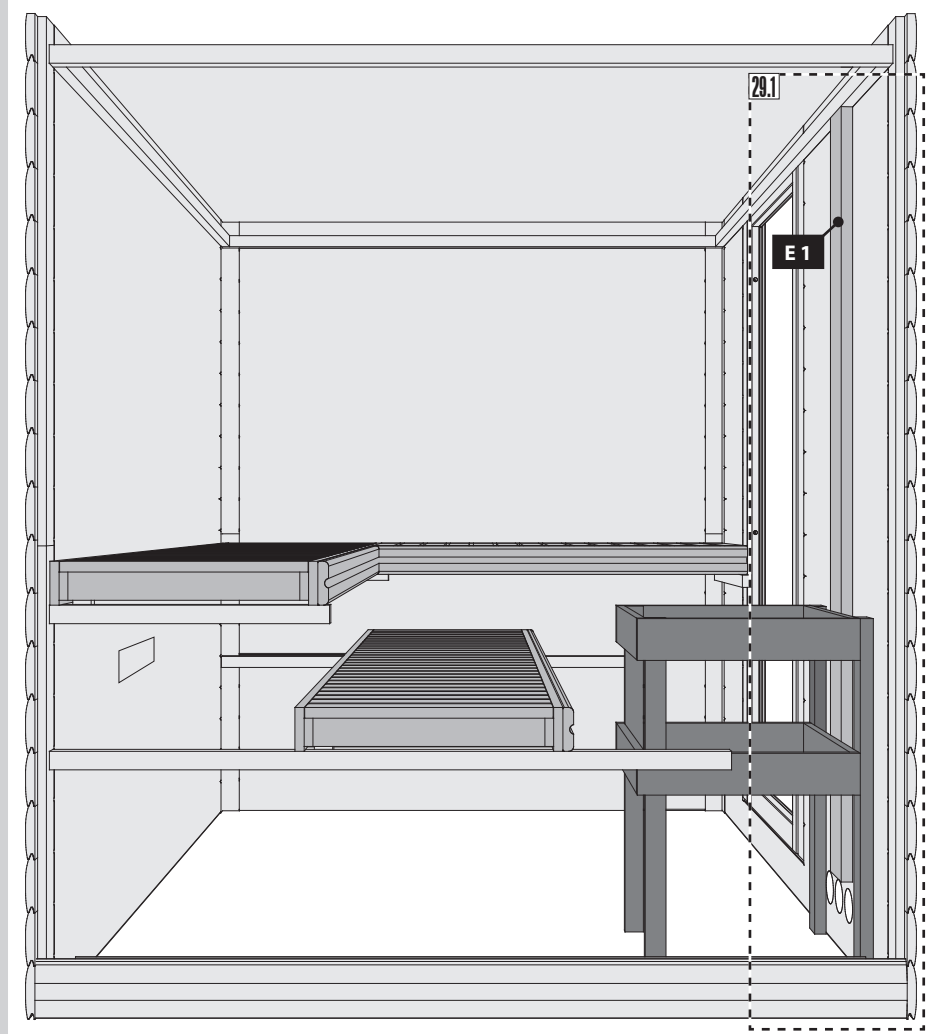

29.1

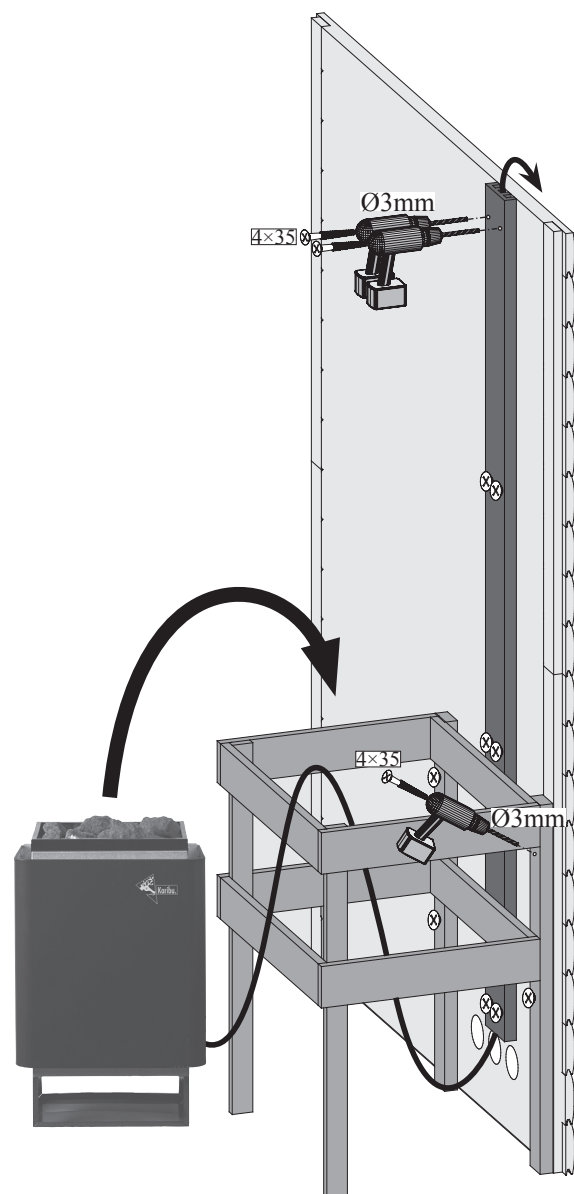

 Einbau Glastür

 Montage van de glazen deur

 Montage porte en verre

 Montaje de la puerta de cristal

 Installation of glass door

 Installazione portello di vetro



04 — 08



 Einbau Glastür

 Installation of glass door

 Montaje de la puerta de cristal

 Montage porte en verre

 Montage van de glazen deur

 Installazione portello di vetro

01

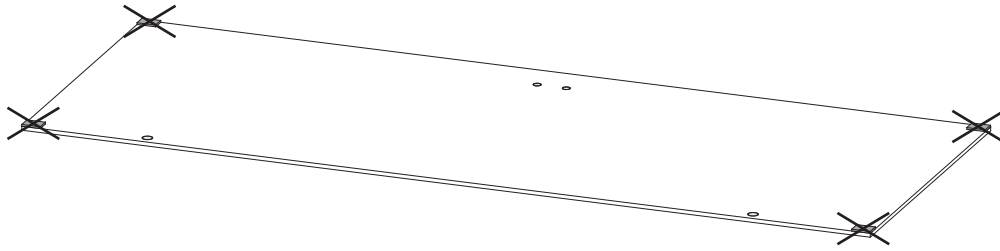

02

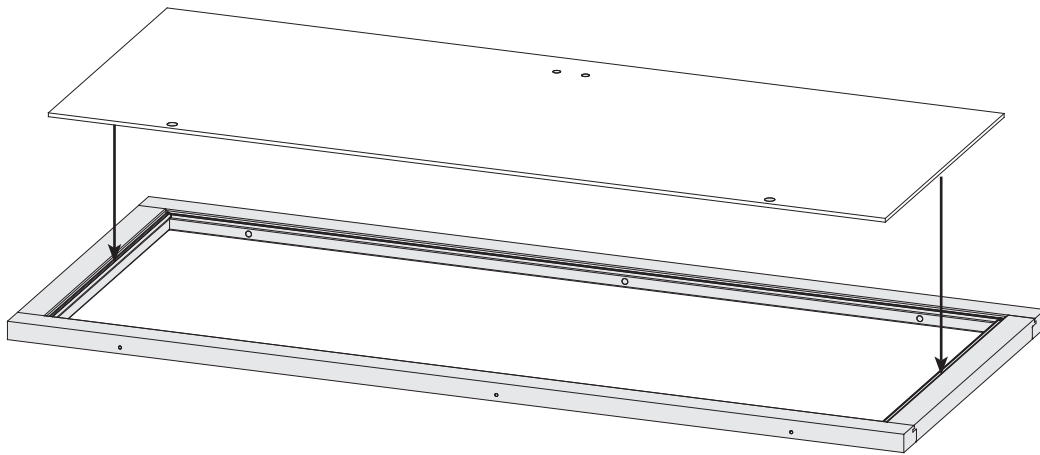



03

 Das Saunätürglas im Türrahmen ausrichten!

 Bien aligner le verre à vitre!

 To start building up the door you need to center the glass in the wooden frame!

 Plaats het glas van de sauna deur in het midden van het kozijn!

 ¡Centrar la puerta de cristal dentro del marco!

 Allineare il vetro dello sportello sauna al telaio della porta!

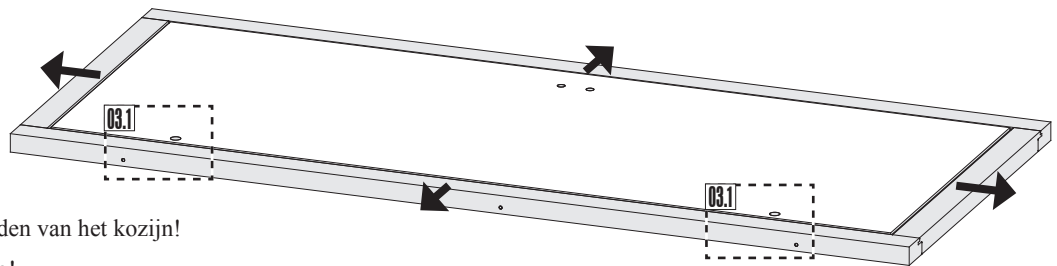

03.1-1

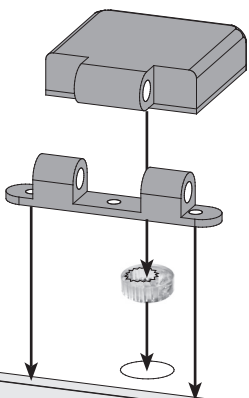

03.1-2

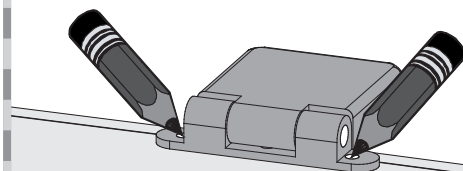

03.1-3

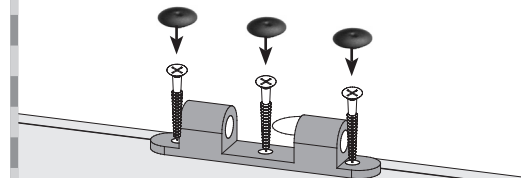

 Einbau Glastür

 Installation of glass door

 Montaje de la puerta de cristal

 Montage porte en verre

 Montage van de glazen deur

 Installazione portello di vetro

04

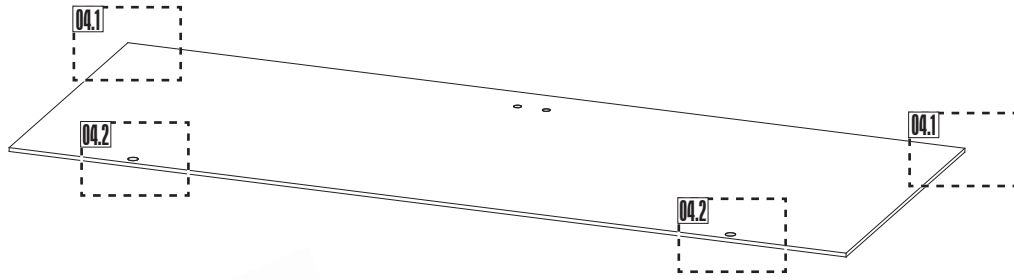

04.1-1

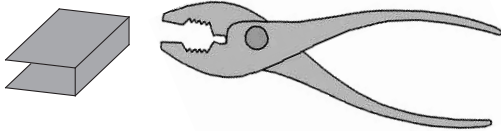

04.1-2

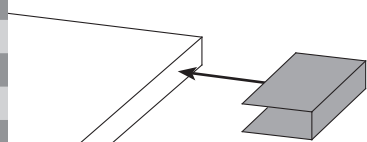

04.1-3

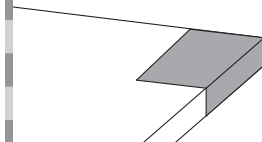

04.2-1

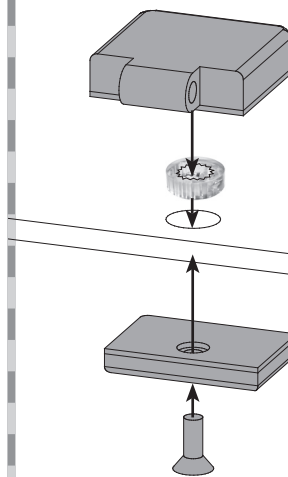

04.2-2

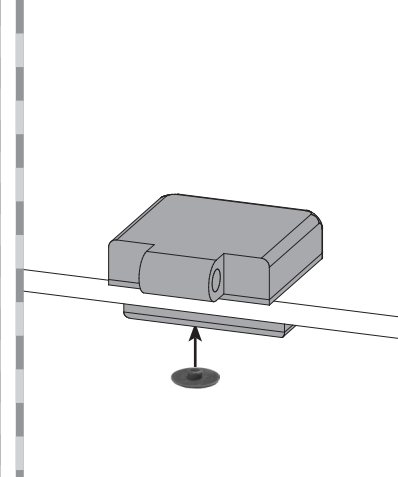

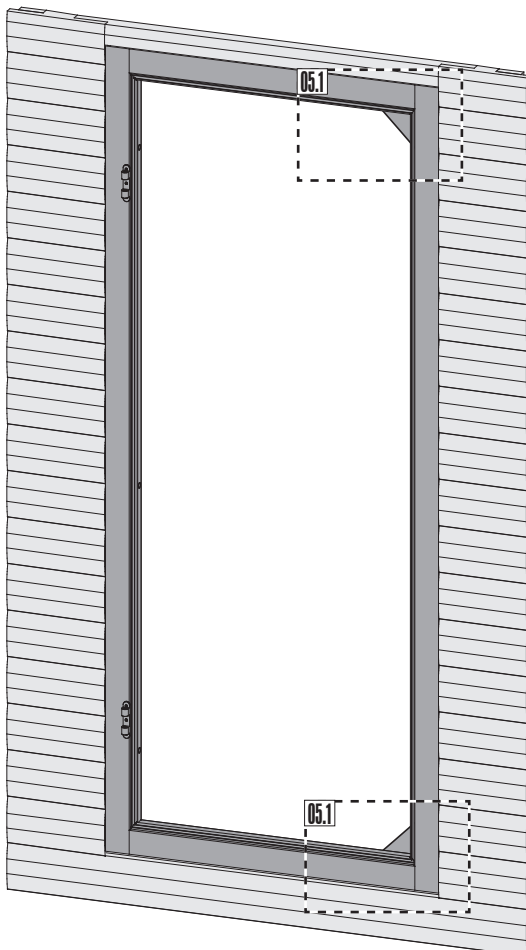

05





 Achtung: Alle Verstell-Excenter müssen in der Glasscheibe die gleiche Grundstellung haben!

 Attention: Tous les excentres de positionnement doivent avoir la même position de base dans la vitre!

 Attention: All adjustable eccentrics must have the same basic adjustment in the glass pane!

 Attentie: alle excentrische verstelelementen moeten in dezelfde stand in de glasplaat worden geplaatst!

 Atención: Todos los excéntricos regulables tienen que tener la misma posición base en la hoja de cristal.

 Attenzione: Tutti gli eccentrici di regolazione devono avere la stessa posizione base nella lastra di vetro!

05.1-1



05.1-2



 Einbau Glastür

 Installation of glass door

 Montaje de la puerta de cristal

 Montage porte en verre

 Montage van de glazen deur

 Installazione portello di vetro

06

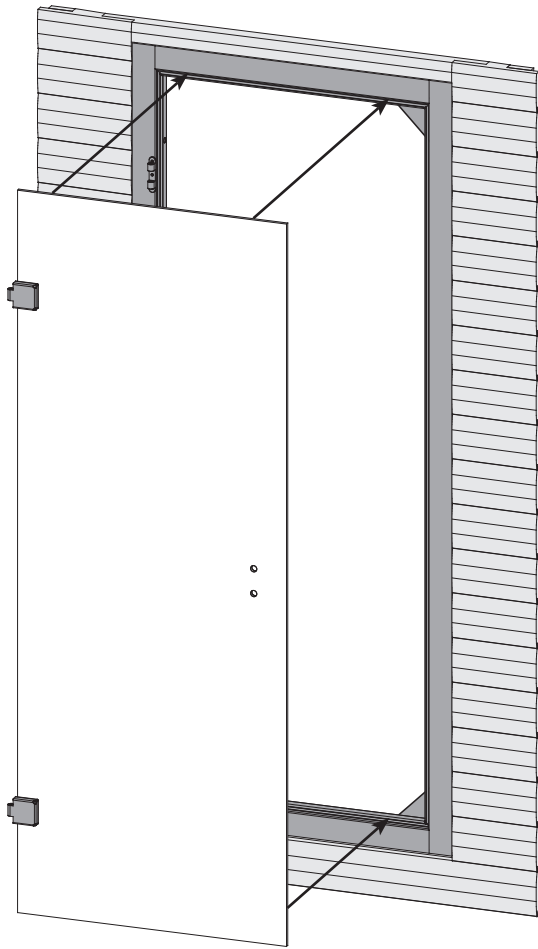

07

07.1

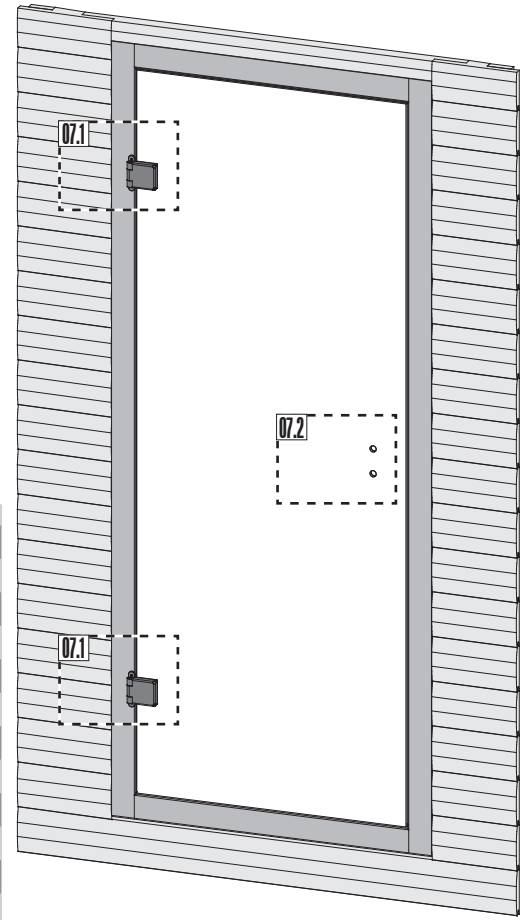
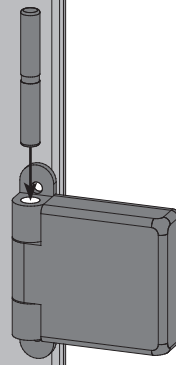

07.2-1

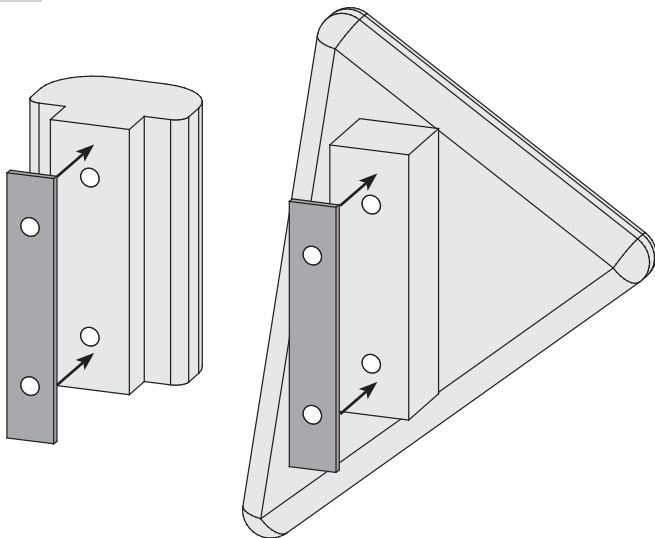

07.2-2

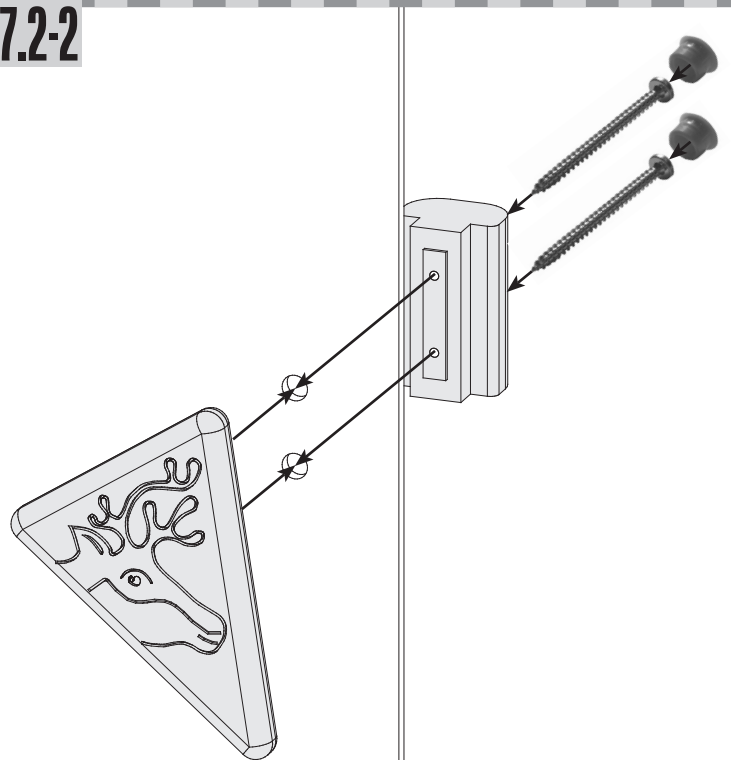

 **Seitenverstellung + Höhenverstellung**

Achtung: Alle Verstell-Excenter müssen in der Glasscheibe die gleiche Grundstellung haben!

 **Positionnement latéral + positionnement hauteur**

Attention: Tous les excentres de positionnement doivent avoir la même position de base dans la vitre!

 **Lateral adjustment + height adjustment**

Attention: All adjustable eccentrics must have the same basic adjustment in the glass panel!

 **Zijverstelling + hoogteverstelling**

Attentie: alle excentrische verstelelementen moeten in dezelfde stand in de glasplaat worden geplaatst!

 **Regulación lateral + regulación de la altura**

Atención: Todos los excéntricos regulables tienen que tener la misma posición base en la hoja de cristal.

 **Regolazione laterale + regolazione dell'altezza**

Attenzione: Tutti gli eccentrici di regolazione devono avere la stessa posizione base nella lastra di vetro!

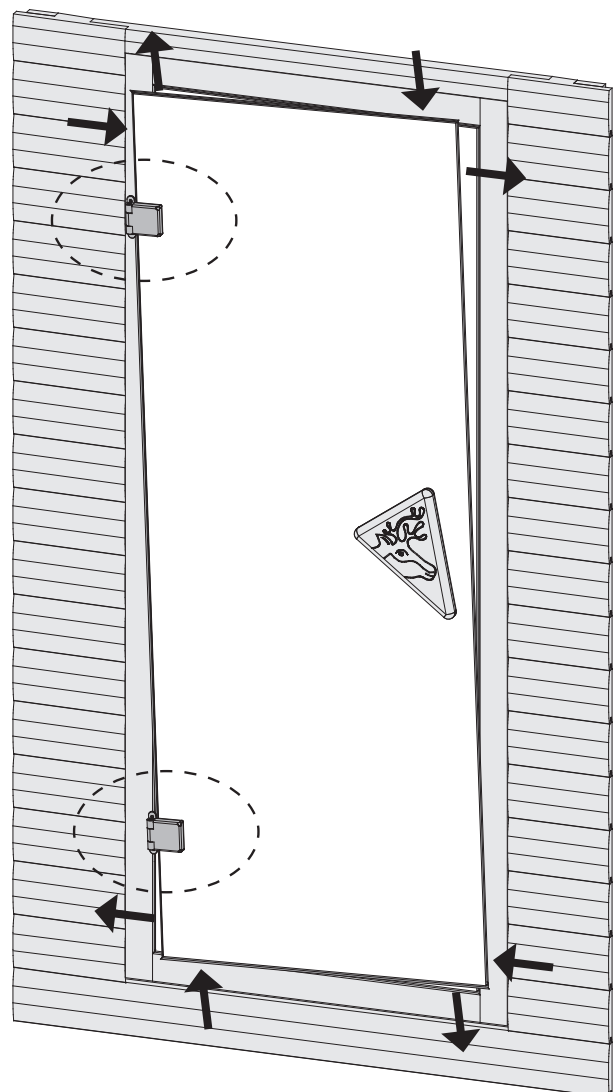
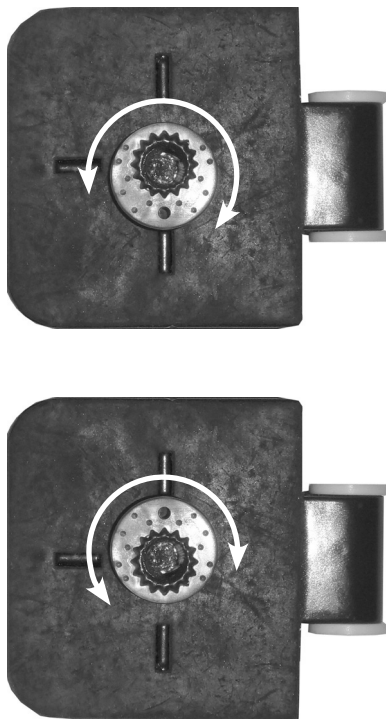

01

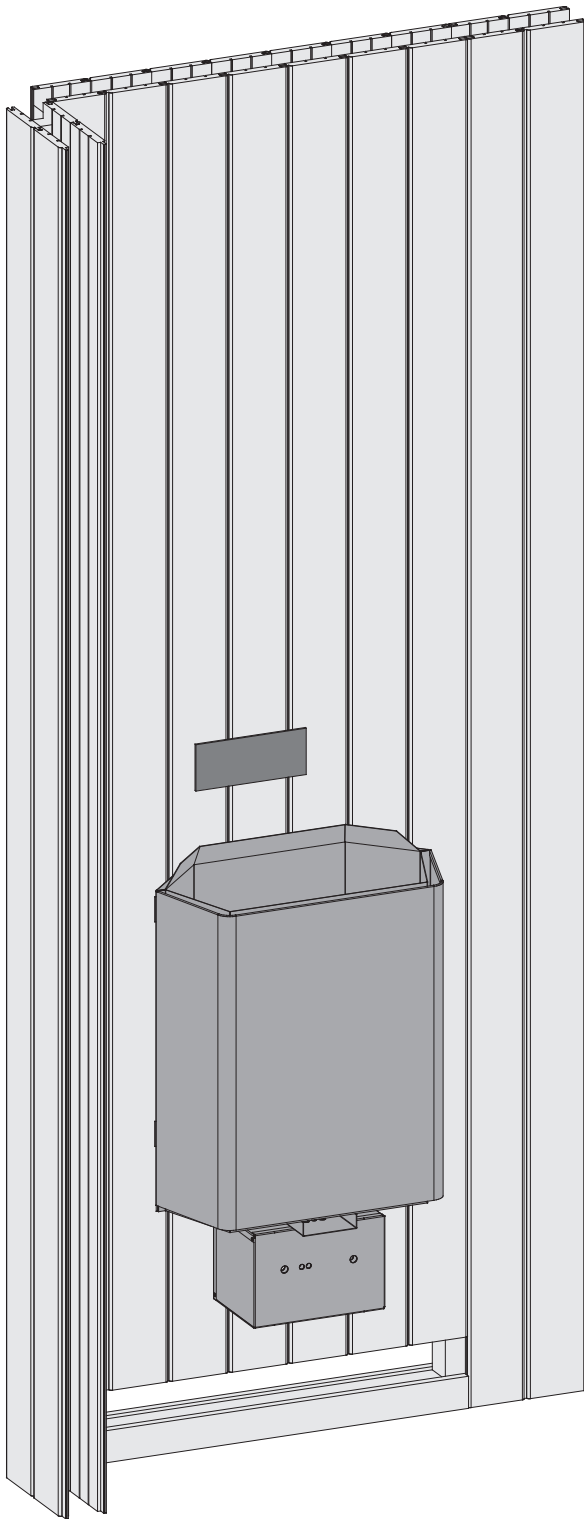

02

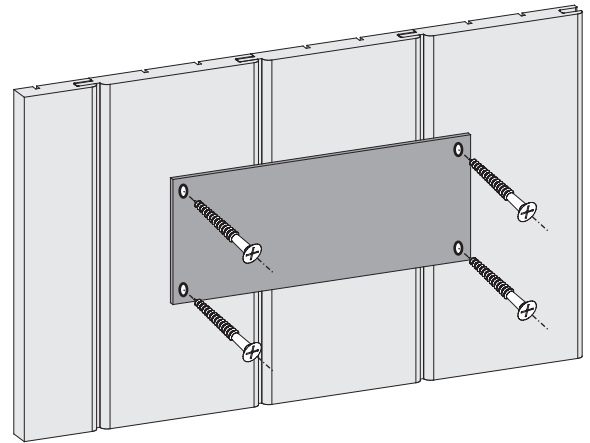

Entfernen Sie die Schutzfolie vom beiliegenden TÜV-Schild.

Lassen Sie den Saunaofen von einem zugelassenen Elektrofachmann anschließen. Dieser markiert den installierten Ofen auf dem TÜV-Schild.

Bringen Sie das TÜV-Schild an einer gut sichtbaren Stelle über dem Ofen an.

