

70 NEGRA Negro | 321.0580.502

FAMILY : Campanas | INSTALLATION TYPE : Decorativa | FINISH : Negro | SERIE : Country | MODEL : 70 NEGRA

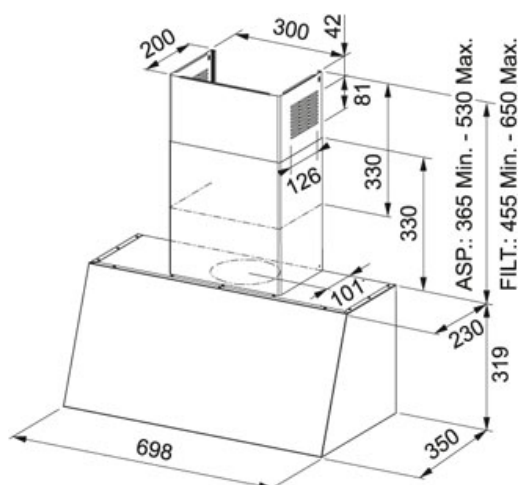

DATOS TÉCNICOS

Potencia Máx. (W)	270 W
Total Power	272-W
Número de velocidades	3
Aspiración en Mín. (UNE EN-61591)	260 m3/h
Aspiración en Máx. (UNE EN-61591)	580 m3/h
Pot. Sonora en Mín. (UNE EN-60704-3)	51 dB(A)
Pot. Sonora en Máx. (UNE EN-60704-3)	66 dB(A)
Iluminación	LEDS 2x1W
Ancho	70,00 cm
Clase Energética	A
Salida	Ø 150 mm
Voltage	220-240V
Grease filter	Filtros de Aluminio
Type of motor	Energy 800 Plus
Acabado	Negro
Pressure	520,00 Pa
Tipo de campana	Decorativa pared

70 NEGRA Negro | 321.0580.502

FAMILY : **Campanas** | INSTALLATION TYPE : **Decorativa** | FINISH : **Negro** | SERIE : **Country** | MODEL : **70 NEGRA**

ACCESORIOS



112.0174.995
